

Model: 01-1182-0010
Custom Towbar
Lockheed Jetstar



03/2007 – Rev. 12

For Spare Parts, Operations & Service Manuals or Service Needs
Scan the QR code or visit Tronair.com/aftermarket



REVISION	DATE	TEXT AFFECTED
11	06/2004	Cover - new illustration, pgs 5 & 7 New illustration
12	03/2007	Added CE marking, Modified Part List

TABLE OF CONTENTS

PAGE

1.0	PRODUCT INFORMATION	1
1.1	DESCRIPTION.....	1
1.2	MODEL & SERIAL NUMBER.....	1
1.3	MANUFACTURER.....	1
1.4	SPECIFICATIONS	1
2.0	SAFETY INFORMATION.....	1
2.1	GENERAL.....	1
3.0	TRAINING.....	1
3.1	TRAINING REQUIREMENTS.....	1
3.2	TRAINING PROGRAM	1
3.3	OPERATOR TRAINING.....	1
4.0	OPERATION.....	2
4.1	LANDING GEAR ASSEMBLY.....	2
4.2	PRELIMINARY CHECKLIST.....	2
4.2.1	Towbar.....	2
4.3	USAGE PROCEDURE.....	2
4.3.1	Aircraft Attachment.....	2
4.3.2	Tug Attachment.....	2
4.3.3	Couplers.....	3
4.3.4	Towing Operation.....	3
5.0	PROVISION OF SPARES.....	4
5.1	SOURCE OF SPARE PARTS.....	4
5.2	RECOMMENDED SPARE PARTS LISTS	4
6.0	IN-SERVICE SUPPORT.....	4
7.0	GUARANTEES	4

Tronair towbars/heads must only be used with matching Tronair heads/towbars, and Tronair shear pins.

This product can not be modified without the written approval of Tronair, Inc. Any modifications done without written approval voids all warranties and releases Tronair, Inc., its suppliers, distributors, employees, or financial institutions from any liability from consequences that may occur. Only Tronair OEM replacement parts shall be used.

1.0 PRODUCT INFORMATION

1.1 DESCRIPTION

The Tronair Model 01-1182-0010 Custom Towbar is designed for towing the Lockheed Jetstar manufactured by Lockheed Corporation.

The custom towbar includes machined hooks which attach to the aircraft tow point. There is an eyebolt at the towing end of the towbar which incorporates a spring to dampen shock loads.

1.2 MODEL & SERIAL NUMBER

Reference nameplate on unit

1.3 MANUFACTURER

TRONAIR, Inc.
1 Air Cargo Pkwy East
Swanton, Ohio 43558 USA

Telephone: (419) 866-6301 or 800-426-6301
Fax: (419) 867-0634
E-mail: sales@tronair.com
Website: www.tronair.com

1.4 SPECIFICATIONS

Aircraft ApplicationLockheed Jetstar manufactured by Lockheed Corporation
Maximum Aircraft Gross Weight.....43,750 lbs (19.8 Metric ton)
Length180 15/16 in (459.6 cm) From eyebolt centerline to end of towbar
Width21 15/16 in (55.7 cm)
Height.....8 in (20.32 cm) From ground to towbar tube centerline.
Tube4 in (10.16 cm) diameter
Weight120 lbs (54.4 kg)
Finish.....Blue Powder Coat
MaterialAluminum

2.0 SAFETY INFORMATION

2.1 GENERAL

The Tronair Model 01-1182-0010 Custom Towbar is used for moving Lockheed Jetstar Aircraft only.

To ensure safe operation, please read the following statements and understand their meaning. This manual contains safety precautions which are explained as follows. Please read carefully.



WARNING! Warning is used to indicate the presence of a hazard that can cause **severe personal injury, death, and/or substantial property damage** if the Warning Notice is ignored.

CAUTION! Caution is used to indicate the presence of a hazard which will or can cause **minor personal injury or property damage** if the Caution Notice is ignored.

3.0 TRAINING

3.1 TRAINING REQUIREMENTS

The employer of the operator is responsible for providing a training program sufficient for the safe operation of the towbar.

3.2 TRAINING PROGRAM

The employer provided operator training program should cover safety procedures concerning use of the towbar in and around the aircraft at the servicing location.

3.3 OPERATOR TRAINING

The operator training should provide the required training for safe operation of the towbar.

NOTE: Maintenance and Trouble Shooting are to be performed by the skilled and trained technician.

4.0 OPERATION

4.1 LANDING GEAR ASSEMBLY

Place landing gear assembly in desired location. Torque clamp nuts to 35 ft-lbs (47.5 N-m).

4.2 PRELIMINARY CHECKLIST

4.2.1 Towbar

- Check towing eye mounting bolts. Ensure the fasteners are not loose or missing.
- Check towing eye for bending, excessive wear and deformity.
- Check the ball lok-T pin. Ensure ball lok-T pin is securely attached to towbar via its lanyard. Ensure ball lok-T pin is not missing.



WARNING!

A damaged or bent towbar should not be used. Towbar should be repaired or replaced.



WARNING!

Towbars should be used with category 1 tugs ONLY in accordance with AHM 995 "Functional specifications for an aircraft tractor" Using a category 2 or higher tug may result in excessive loads and stresses being applied to the towbar and/or the aircraft. These excessive loads may cause failure of the towbar which could cause damage to the aircraft or personal injury.

4.3 USAGE PROCEDURE

4.3.1 Aircraft Attachment



CAUTION!

It is recommended that your towbar to attached to the aircraft first, and then connected to the tug to avoid possible aircraft damage.

4.3.2 Tug Attachment



CAUTION!

Damage to the towbar or aircraft can result from an excessive towbar angle during towing operations. Reference Figure 1.

- Use a pintle height so that the towbar is as level as possible during towing. Also, the pintle hook height should prevent contact of the towbar with the ground during towing.

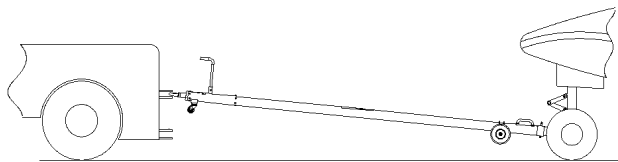

**Incorrect
Excessive Towbar Angle**

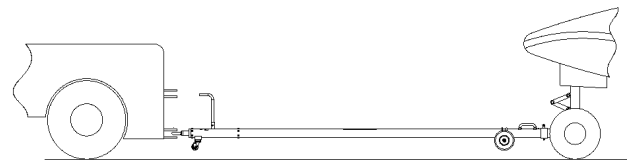

Correct

FIGURE 1

4.3.3 Couplers



CAUTION!

Damage to the towbar or aircraft can result while towing with the following types of couplers:

- Lift Head
- Standard Duty Latch
- Vertical Side Swing Latch
- Swivel Hook

The couplers listed above are known to cause binding and failure in the lunette eye. Indicators of binding are wear on outside diameter of the eyebolt and indentation on the inside diameter of the eyebolt. **Reference Figure 2.**

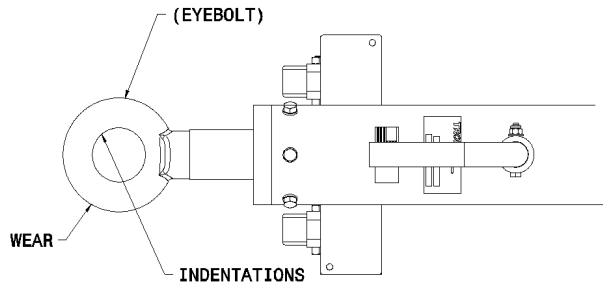

FIGURE 2

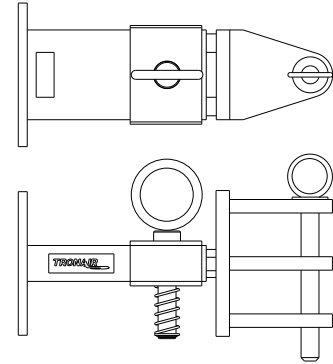

FIGURE 3
01-1950-5000 Standard Telecoupler

Tronair recommends a telecoupler pintle hook arrangement. This arrangement is known to eliminate binding. Tronair offers a Standard Telecoupler, Model Number 01-1950-5000, for use on tugs. **Reference Figure 3.**

Damage to the towbar and/or aircraft can result by towing or pushing an aircraft with an incorrect size eyebolt or pintle pin. A correct size eyebolt will make contact with the pintle pin. A gap between the eyebolt outside diameter and the coupler face plate should be easily seen. An eyebolt which is too large will cause the eyebolt to make contact with the face plate of the coupler. When the eyebolt is too large for the coupler, a gap between the inside diameter of the eyebolt and the coupler face plate will be seen. Reference Figure 4.

To ensure proper towing and pushing, check to make sure the pintle pin diameter is not too long for the eyebolt's inside diameter. An approximate one-half inch ($\frac{1}{2}$ ") gap between the pin diameter and the eyebolt should be seen. If any of these conditions are not met, please contact Tronair for information to obtain a new coupler.

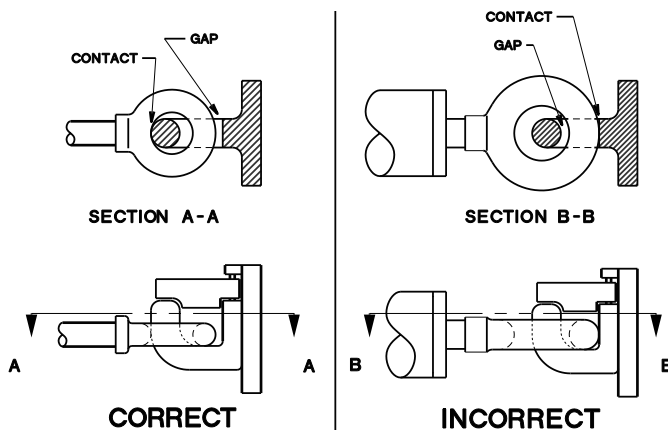

FIGURE 4

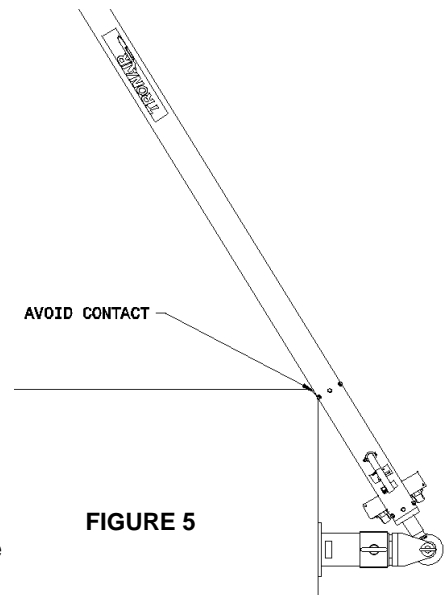

FIGURE 5

4.3.4 Towing Operation

Damage to the towbar or aircraft can result from pushing an aircraft while maintaining too sharp of an angle between the tug and the aircraft. Contact between the towbar weldment and the tug must be avoided. It is recommended that the angle between the tug and towbar not exceed 90°. **Reference Figure 5.**

5.0 PROVISION OF SPARES**5.1 SOURCE OF SPARE PARTS**

Spare parts may be obtained from the manufacturer:

TRONAIR, Inc.

1 Air Cargo Pkwy East
Swanton, Ohio 43558 USA

Telephone: (419) 866-6301 or 800-426-6301

Fax: (419) 867-0634

E-mail: sales@tronair.com

Website: www.tronair.com

For Spare Parts, Operations & Service Manuals or Service Needs:
Scan the QR code or visit Tronair.com/aftermarket

**5.2 RECOMMENDED SPARE PARTS LISTS**

Reference the following page(s) for Replacement Parts and Kits available.

Recommended Spares to be kept on hand:

U-1000 Swivel Caster

K-1143..... Wheel (Single) Replacement

6.0 IN-SERVICE SUPPORT

Contact Tronair, Inc. for technical services and information. See Section 1.3 – Manufacturer.

7.0 GUARANTEES

Tronair products are warranted to be free of manufacturing or material defects for a period of one year after shipment to the original customer. This is solely limited to the repair or replacement of defective components. This warranty does not cover the following items:

- a) Parts required for normal maintenance
- b) Parts covered by a component manufacturers warranty
- c) Replacement parts have a 90-day warranty from date of shipment

If you have a problem that may require service, contact Tronair immediately. Do not attempt to repair or disassemble a product without first contacting Tronair, any action may affect warranty coverage. When you contact Tronair be prepared to provide the following information:

- a) Product Model Number
- b) Product Serial Number
- c) Description of the problem

If warranty coverage is approved, either replacement parts will be sent or the product will have to be returned to Tronair for repairs. If the product is to be returned, a Return Material Authorization (RMA) number will be issued for reference purposes on any shipping documents. Failure to obtain a RMA in advance of returning an item will result in a service fee. A decision on the extent of warranty coverage on returned products is reserved pending inspection at Tronair. Any shipments to Tronair must be shipped freight prepaid. Freight costs on shipments to customers will be paid by Tronair on any warranty claims only. Any unauthorized modification of the Tronair products or use of the Tronair products in violation of cautions and warnings in any manual (including updates) or safety bulletins published or delivered by Tronair will immediately void any warranty, express or implied.

The obligations of Tronair expressly stated herein are in lieu of all other warranties or conditions expressed or implied. **Any unauthorized modification of the Tronair products or use of the Tronair products in violations of cautions and warnings in any manual (including updates) or safety bulletins published or delivered by Tronair will immediately void any warranty, express or implied and Tronair disclaims any and all liability for injury (WITHOUT LIMITATION and including DEATH), loss or damage arising from or relating to such misuse.**

Parts List

When ordering replacement parts/kits, please specify model, serial number and color of your unit.

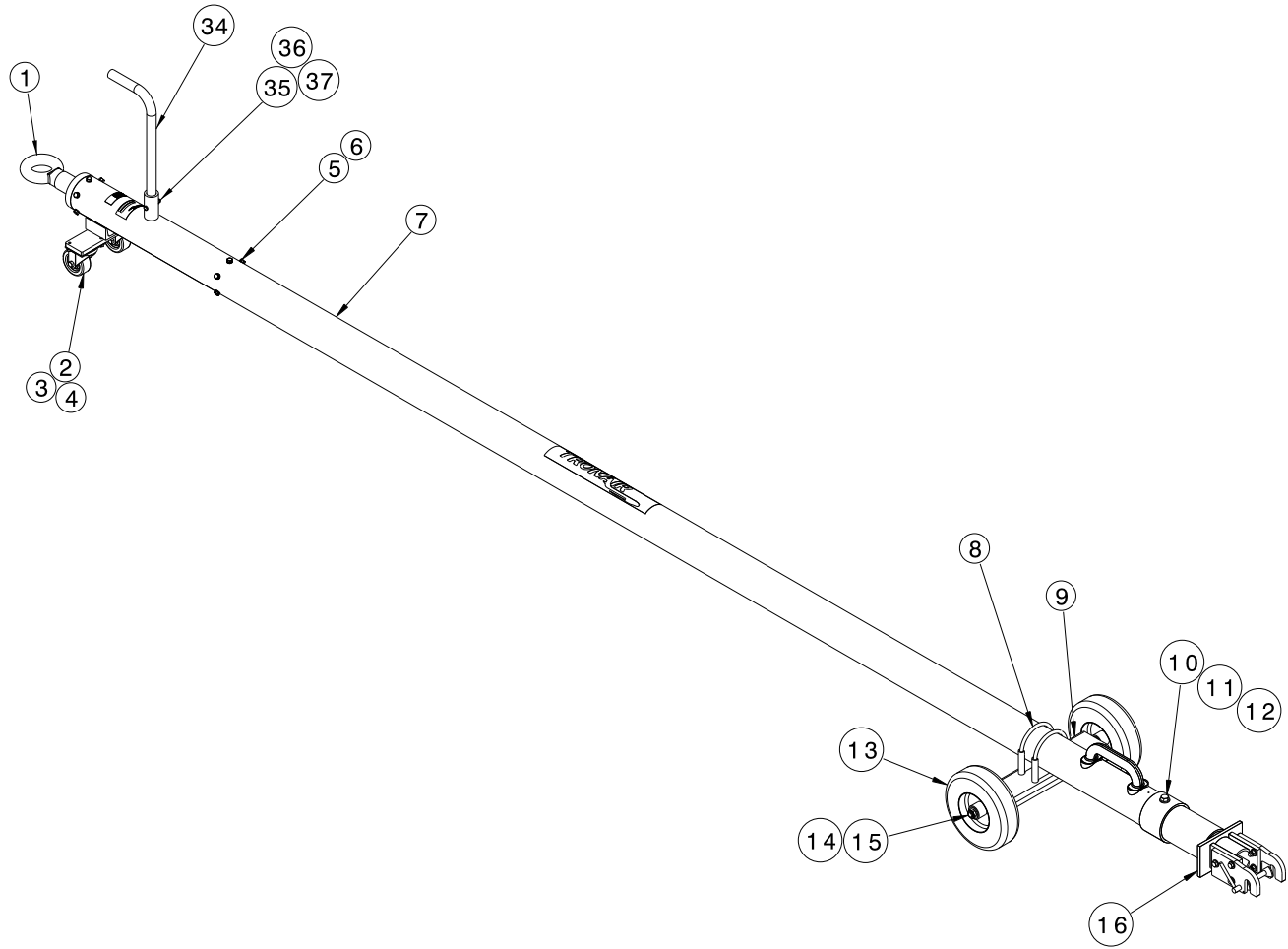

Parts List

When ordering replacement parts/kits, please specify model, serial number and color of your unit.

Item	Part Number	Description	Qty
1	Z-3999	ASSEMBLY, SHOCK	1
▶ 2	U-1000	CASTER, SWIVEL	2
3	G-1251-1060R	LOCKWASHER, $\frac{5}{16}$ REGULAR	4
4	G-1100-106004	BOLT, HEX HEAD, GRADE 5, $\frac{5}{16}$ -18 X $\frac{1}{2}$ " LONG	4
5	G-1420-106006	BOLT, HEX HEAD, GRADE 5, $\frac{5}{16}$ -18 X $\frac{3}{4}$ " LONG	12
6	G-1251-1060R	LOCKWASHER, $\frac{5}{16}$ REGULAR	12
7	Z-6514-02-01	MACHINING, TOWBAR	1
8	H-1537-08	CLAMP, MUFFLER	2
9	Z-5643-01	WELDMENT, AXLE MOUNTING	1
10	G-1100-109554	BOLT, HEX HEAD, GRADE 5, $\frac{1}{2}$ -20 X 5-1/2" LONG	1
11	G-1250-1090N	FLATWASHER, $\frac{1}{2}$ NARROW	1
12	G-1203-1095	JAMNUT, $\frac{1}{2}$ -20 ELASTIC	1
16	X-1080	ASSEMBLY, HEAD	1
34	TR-1857-01	TUBE, HANDLE	1
35	G-1100-105520	BOLT, HEX HEAD, GRADE 5, $\frac{1}{4}$ -28 X 2" LONG	1
36	G-1202-1055	STOPNUT, $\frac{1}{4}$ -28 ELASTIC	1
37	G-1250-1050N	FLATWASHER, $\frac{1}{4}$ NARROW	1
	K-1143	KIT, WHEEL (SINGLE) REPLACEMENT ; <i>consists of:</i>	
13	U-1021	WHEEL, PNEUMATIC TIRE	1
14	G-1203-1105	JAMNUT, $\frac{5}{8}$ -18 ELASTIC	1
15	G-1250-1100N	FLATWASHER, $\frac{5}{8}$ NARROW	1

Item 1 consists of items which are not sold separately. Due to the high compression used in assembly, it is suggested this Shock Assembly be returned to Tronair for repair. Discuss with your Salesperson.

▶ Use Loctite 271 or equivalent during re-assembly.

Parts List

When ordering replacement parts/kits, please specify model, serial number and color of your unit.

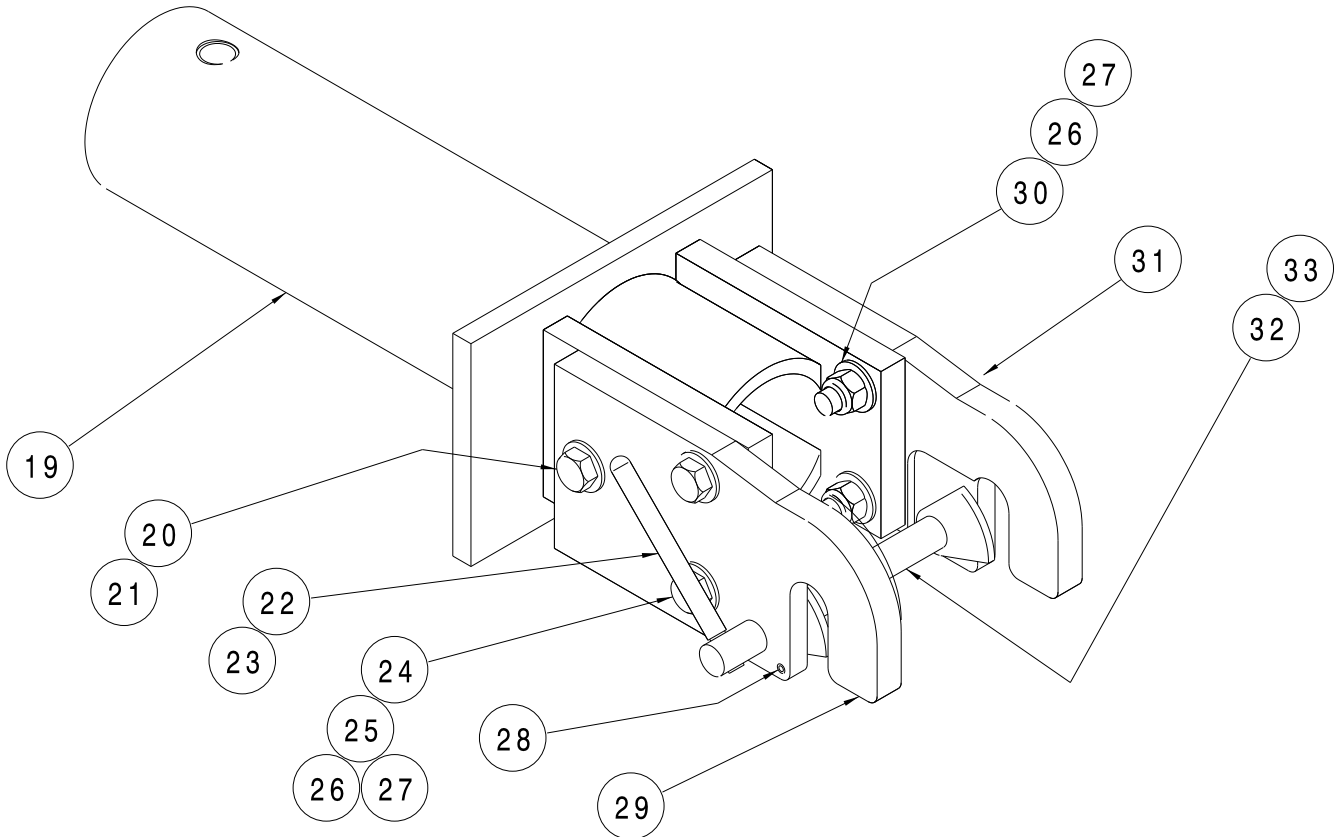

Item	Part Number	Description	Qty
	X-1080	ASSEMBLY, HEAD; <i>consists of:</i>	
19	Z-3699-01	WELDMENT, HEAD	1
20	G-1100-107512	BOLT, HEX HEAD, GRADE 5, 3/8-24 X 1 1/4" LONG	2
21	G-1251-1070R	LOCKWASHER, 3/8 REGULAR	2
22	G-1300-25340	PIN, ROLL	1
23	H-1205	COVER, RED HANDLE	1
24	G-1100-107520	BOLT, HEX HEAD, GRADE 5, 3/8-24 X 2" LONG	1
25	G-1250-1070N	FLATWASHER, 3/8 NARROW	9
26	G-1202-1075	STOPNUT, 3/8-24 ELASTIC	4
27	G-1250-1070W	FLATWASHER, 3/8 WIDE	1
28	G-1300-16040	PIN, ROLL	1
29	J-1268	ADAPTOR AXLE	1
30	G-1100-107516	BOLT, HEX HEAD, GRADE 5, 3/8-24 X 1 3/4" LONG	3
31	J-1269	ADAPTOR, AXLE	1
32	Z-0130	WELDMENT, AXLE LOCKING	1
33	G-1300-16050	PIN, ROLL	1



APPENDIX I

Declaration of Conformity



DECLARATION of CONFORMITY

The design, development and manufacture is in accordance with European Community guidelines

Custom Towbar
01-1182-0010

Relevant provisions complied with by the machinery:
2006/42/EC

Relevant standards complied with by the machinery:
EN ISO 12100-1

Identification of person empowered to sign on behalf of the manufacturer:

Quality Assurance Representative

