

**Model: 01-1183-0000**  
**Custom Towbar**  
**Falcon 10, 20**



04/2023 – Rev. 11

**For Spare Parts, Operations & Service Manuals or Service Needs**  
**Scan the QR code or visit [Tronair.com/aftermarket](http://Tronair.com/aftermarket)**



REVISION	DATE	TEXT AFFECTED
10	11/2007	Added Declaration of Conformity and CE marking, Modified Parts Lists
11	04/2023	Major revision

**TABLE OF CONTENTS**

**PAGE**

<b>1.0</b>	<b>PRODUCT INFORMATION .....</b>	<b>1</b>
1.1	DESCRIPTION.....	1
1.2	MODEL & SERIAL NUMBER.....	1
1.3	MANUFACTURER.....	1
1.4	SPECIFICATIONS .....	1
<b>2.0</b>	<b>SAFETY INFORMATION.....</b>	<b>1</b>
2.1	GENERAL.....	1
<b>3.0</b>	<b>TRAINING.....</b>	<b>2</b>
3.1	TRAINING REQUIREMENTS.....	2
3.2	TRAINING PROGRAM .....	2
3.3	OPERATOR TRAINING.....	2
<b>4.0</b>	<b>OPERATION.....</b>	<b>2</b>
4.1	LANDING GEAR ASSEMBLY.....	2
4.2	PRELIMINARY CHECKLIST.....	2
4.2.1	Towbar.....	2
4.2.2	Towing Head.....	2
4.3	USAGE PROCEDURE.....	2
4.3.1	Aircraft Attachment.....	2
4.3.2	Tug Attachment.....	2
4.3.3	Couplers.....	3
4.4	TOWING OPERATION .....	3
<b>5.0</b>	<b>PROVISION OF SPARES.....</b>	<b>4</b>
5.1	SOURCE OF SPARE PARTS.....	4
5.2	RECOMMENDED SPARE PARTS LISTS .....	4
<b>6.0</b>	<b>IN-SERVICE SUPPORT.....</b>	<b>4</b>
<b>7.0</b>	<b>GUARANTEES .....</b>	<b>4</b>

Tronair towbars/heads must only be used with matching Tronair heads/towbars, and Tronair shear pins.

This product can not be modified without the written approval of Tronair, Inc. Any modifications done without written approval voids all warranties and releases Tronair, Inc., its suppliers, distributors, employees, or financial institutions from any liability from consequences that may occur. Only Tronair OEM replacement parts shall be used.

## 1.0 PRODUCT INFORMATION

### 1.1 DESCRIPTION

The Tronair Model 01-1183-0000 custom towbar is designed for towing the Falcon 10 or Falcon 20 manufactured by Dassault.

The custom towbar has an aircraft attachment by machined hooks on the towing head to the nose landing gear tow point. There is a handle and an eyebolt at the end of the towbar for towing.

### 1.2 MODEL & SERIAL NUMBER

Reference nameplate on unit

### 1.3 MANUFACTURER

**TRONAIR**, Inc.  
1 Air Cargo Pkwy East  
Swanton, Ohio 43558 USA

Telephone: (419) 866-6301 or 800-426-6301  
Fax: (419) 867-0634  
E-mail: sales@tronair.com  
Website: www.tronair.com

### 1.4 SPECIFICATIONS

Aircraft Application .....Falcon 10, 20 Aircraft manufactured by Dassault  
Maximum Aircraft Gross Weight.....32,000 lbs (14.5 Metric tons)  
Length .....140-5/8 in (357 cm) From eyebolt centerline to aircraft attachment centerline  
Width .....22-7/8 in (58.1 cm)  
Height .....7-13/16 in (19.8 cm) From ground to aircraft attachment centerline  
Weight .....126 lbs (57.2 kg)  
Finish.....Blue Powder Coat

## 2.0 SAFETY INFORMATION

### 2.1 GENERAL

The Tronair Model 01-1183-0000 Custom Towbar is to be used for moving the Falcon 10 or 20 Aircraft only.

To ensure safe operation, please read the following statements and understand their meaning. This manual contains safety precautions which are explained as follows. Please read carefully.



**WARNING!** Warning is used to indicate the presence of a hazard that can cause **severe personal injury, death, and/or substantial property damage** if the Warning Notice is ignored.

**CAUTION!** Caution is used to indicate the presence of a hazard which will or can **cause minor personal injury or property damage** if the Caution Notice is ignored.



**WARNING!**

**A damaged or bent towbar should not be used. Towbar should be repaired or replaced.**



**WARNING!**

**Towbars should be used with category 1 tugs ONLY in accordance with AHM 995 “Functional specifications for an aircraft tractor” Using a category 2 or higher tug may result in excessive loads and stresses being applied to the towbar and/or the aircraft. These excessive loads may cause failure of the towbar which could cause damage to the aircraft or personal injury.**

### 3.0 TRAINING

#### 3.1 TRAINING REQUIREMENTS

The employer of the operator is responsible for providing a training program sufficient for the safe operation of the towbar.

#### 3.2 TRAINING PROGRAM

The employer provided operator training program should cover safety procedures concerning use of the towbar in and around the aircraft at the servicing location.

#### 3.3 OPERATOR TRAINING

The operator training should provide the required training for safe operation of the towbar.

**NOTE: Maintenance and Trouble Shooting are to be performed by the skilled and trained technician.**

### 4.0 OPERATION

#### 4.1 LANDING GEAR ASSEMBLY

Place landing gear assembly in desired location. Torque clamp nuts to 35 ft-lbs (47.5 N-m).

#### 4.2 PRELIMINARY CHECKLIST

##### 4.2.1 Towbar

- Check towing eye mounting bolts. Ensure fasteners are not loose or missing.
- Check towing eye for bending, excessive wear and/or deformity.
- Check shear pin. Ensure shear pin is not broken or missing; replace as required.



#### WARNING!

**Towing an aircraft using a towbar with a broken or missing shear pin may cause damage to the aircraft.**

##### 4.2.2 Towing Head

- Check welds between side rails and head rail for cracks:
- Check welds between head plate, connector tube, and shear plates for cracks.
- Check shear pin to ensure it has not broke; replace if necessary.
- Check fastener connection of towing head to towbar. Ensure the connection is not loose or missing.
- Check shear pin bushings. Ensure they are not cracked or chipped.
- Check hooks on towing head for bending or excessive wear.
- Check pivot bolt. Ensure connection is secure.
- Check axle locking mechanism, ensure operation of lock lever and cam. Inspect for excessive wear or damage. Replace if necessary.

#### 4.3 USAGE PROCEDURE

##### 4.3.1 Aircraft Attachment



#### CAUTION!

**It is recommended that your towbar to attached to the aircraft first, and then connected to the tug to avoid possible aircraft damage.**

##### 4.3.2 Tug Attachment

- Use a pintle height so that the towbar is as level as possible during towing. Also, the pintle hook height should prevent contact of the towbar with the ground during towing.



#### CAUTION!

**Damage to the towbar or aircraft can result from an excessive towbar angle during towing operations. Reference Figure 1.**

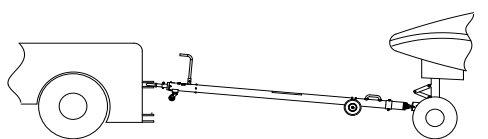

**Incorrect  
Excessive Towbar Angle**

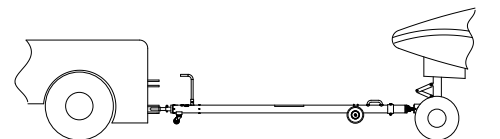

**Correct**

**Figure 1**

4.3.3 Couplers



**CAUTION!**

Damage to the towbar or aircraft can result while towing with the following types of couplers:

- Lift Head
- Vertical Side Swing Latch
- Standard Duty Latch
- Swivel Hook

The couplers listed above are known to cause binding and failure in the eyebolt. Indicators of binding are wear on outside diameter of the eyebolt and indentation on the inside diameter of the eyebolt. **Reference Figure 2.**

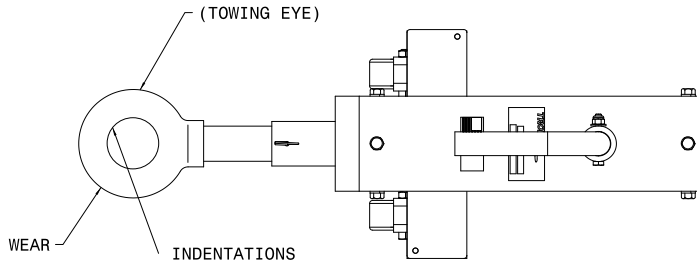

**Figure 2**

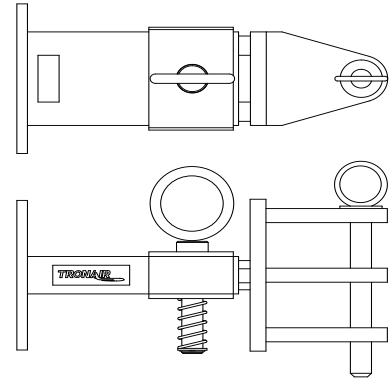
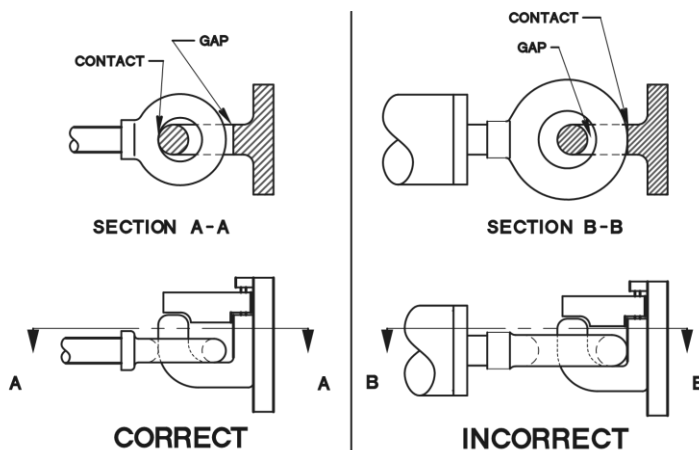

**FIGURE 3**  
01-1950-5000 Standard Telecoupler

Tronair recommends a telecoupler pintle hook arrangement. This arrangement is known to eliminate binding. Tronair offers a Standard Telecoupler, Model Number 01-1950-5000, for use on tugs. **Reference Figure 3.**

Damage to the towbar and/or aircraft can result by towing or pushing an aircraft with an incorrect size eyebolt or pintle pin. A correct size eyebolt will make contact with the pintle pin. A gap between the eyebolt outside diameter and the coupler face plate should be easily seen. An eyebolt which is too large will cause the eyebolt to make contact with the face plate of the coupler. When the eyebolt is too large for the coupler, a gap between the inside diameter of the eyebolt and the coupler face plate will be seen. **Reference Figure 4.**

To ensure proper towing and pushing, check to make sure the pintle pin diameter is not too long for the eyebolt's inside diameter. An approximate one-half inch (1/2") gap between the pin diameter and the eyebolt should be seen. If any of these conditions are not met, please contact Tronair for information to obtain a new coupler.



**FIGURE 4**

4.4 TOWING OPERATION

Damage to the towbar or aircraft can result from pushing an aircraft while maintaining too sharp of an angle between the tug and the aircraft. Contact between the towbar weldment and the tug must be avoided. It is recommended that the angle between the tug and towbar not exceed 90°. **Reference Figure 5**

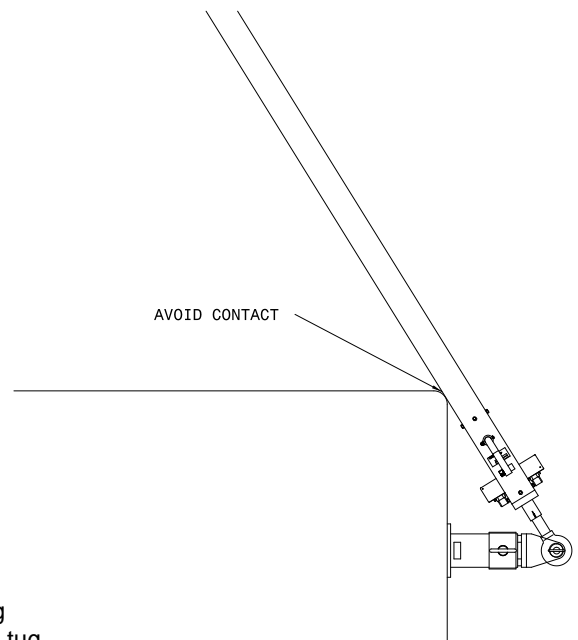

**FIGURE 5**

## 5.0 PROVISION OF SPARES

### 5.1 SOURCE OF SPARE PARTS

Spare parts may be obtained from the manufacturer:

<b>TRONAIR</b> , Inc.	Telephone: (419) 866-6301 or 800-426-6301
1 Air Cargo Pkwy East	Fax: (419) 867-0634
Swanton, Ohio 43558 USA	E-mail: sales@tronair.com
	Website: www.tronair.com

For Spare Parts, Operations & Service Manuals or Service Needs:  
Scan the QR code or visit Tronair.com/aftermarket



### 5.2 RECOMMENDED SPARE PARTS LISTS

Reference the following page(s) for Replacement Parts and Kits available.

Recommended Spares to be kept on hand:  
K-1446.....Kit, Shear Bolt Replacement  
K-1447.....Kit, Bushing Pin Replacement  
K-1676.....Kit, Adapter Set Replacement

## 6.0 IN-SERVICE SUPPORT

Contact Tronair, Inc. for technical services and information. See Section 1.3 – Manufacturer.

## 7.0 GUARANTEES

Tronair products are warranted to be free of manufacturing or material defects for a period of one year after shipment to the original customer. This is solely limited to the repair or replacement of defective components. This warranty does not cover the following items:

- a) Parts required for normal maintenance
- b) Parts covered by a component manufacturers warranty
- c) Replacement parts have a 90-day warranty from date of shipment

If you have a problem that may require service, contact Tronair immediately. Do not attempt to repair or disassemble a product without first contacting Tronair, any action may affect warranty coverage. When you contact Tronair be prepared to provide the following information:

- a) Product Model Number
- b) Product Serial Number
- c) Description of the problem

If warranty coverage is approved, either replacement parts will be sent or the product will have to be returned to Tronair for repairs. If the product is to be returned, a Return Material Authorization (RMA) number will be issued for reference purposes on any shipping documents. Failure to obtain a RMA in advance of returning an item will result in a service fee. A decision on the extent of warranty coverage on returned products is reserved pending inspection at Tronair. Any shipments to Tronair must be shipped freight prepaid. Freight costs on shipments to customers will be paid by Tronair on any warranty claims only. Any unauthorized modification of the Tronair products or use of the Tronair products in violation of cautions and warnings in any manual (including updates) or safety bulletins published or delivered by Tronair will immediately void any warranty, express or implied.

The obligations of Tronair expressly stated herein are in lieu of all other warranties or conditions expressed or implied. **Any unauthorized modification of the Tronair products or use of the Tronair products in violations of cautions and warnings in any manual (including updates) or safety bulletins published or delivered by Tronair will immediately void any warranty, express or implied and Tronair disclaims any and all liability for injury (WITHOUT LIMITATION and including DEATH), loss or damage arising from or relating to such misuse.**

### Parts List

When ordering replacement parts/kits, please specify model, serial number and color of your unit.

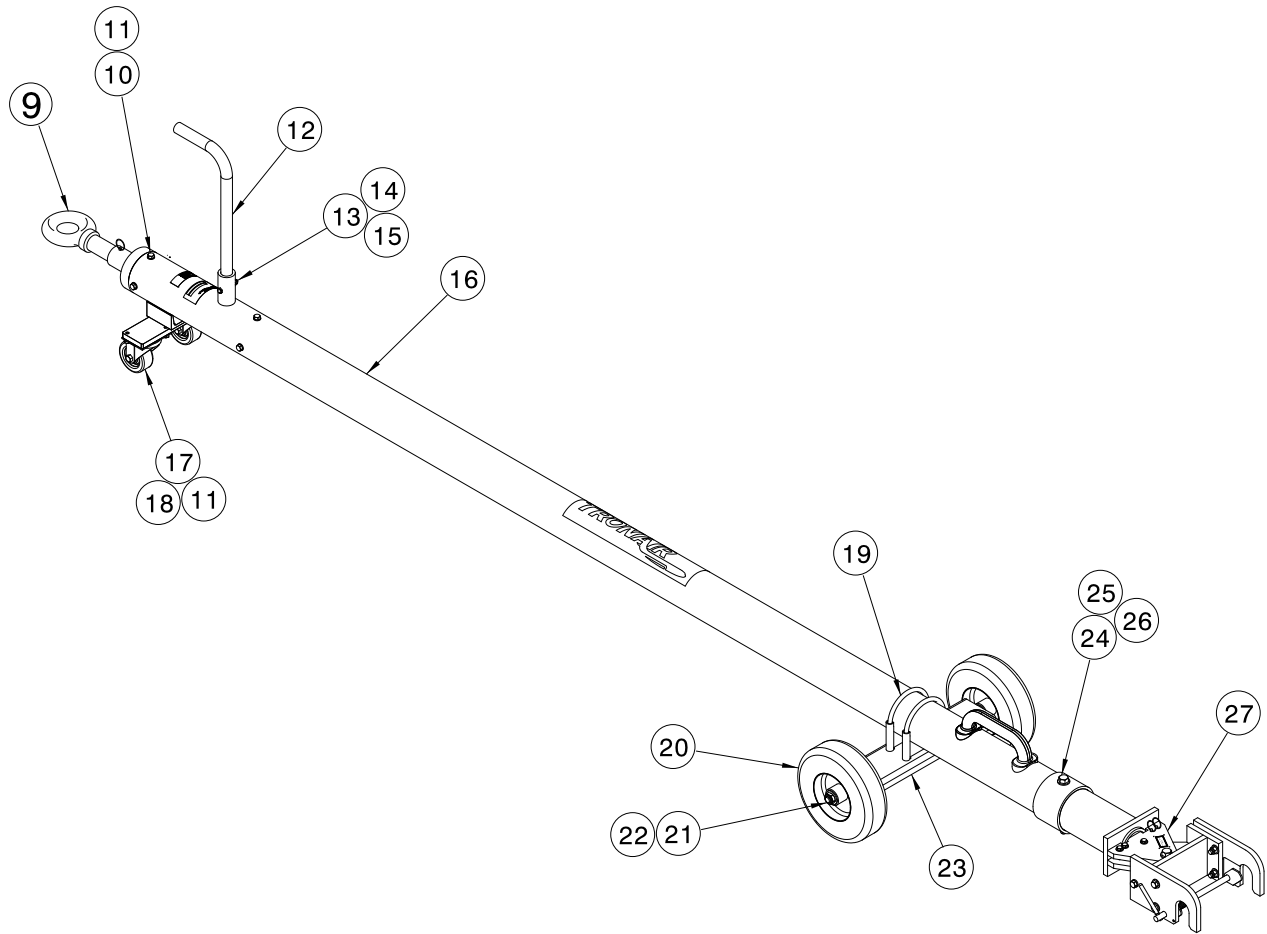

Item	Part Number	Description	Qty
9	Z-0004	ASSEMBLY, SHOCK/SHEAR	1
10	G-1420-106006	BOLT, HEX HEAD, GRADE 8, 5/16-18 X 3/4" LG	8
11	G-1251-1060R	LOCKWASHER, 5/16 REGULAR	12
12	TR-1857-01	TUBE, HANDLE	1
13	G-1100-105520	BOLT, HEX HEAD, GRADE 5, 1/4-28 X 2" LG	1
14	G-1250-1050N	FLATWASHER, 1/4 NARROW	7
15	G-1202-1055	STOPNUT, 1/4 - 28 ELASTIC	4
16	Z-5945-01	MACHINING, TOWBAR	1
17	U-1000	CASTER, SWIVEL	2
18	G-1100-106005	BOLT, HEX HEAD, GRADE 5, 5/16 - 18 X 5/8" LG	4
19	H-1537-08	CLAMP, MUFLER	2
20	U-1024	WHEEL, PNEUMATIC TIRE	2
21	G-1203-1105	JAMNUT, 5/8 -16 ELASTIC	2
22	G-1250-1100N	FLATWASHER, 5/8 NARROW	4
23	Z-5643-01	WELDMENT, AXLE MOUNTING	1
24	G-1250-1090N	FLATWASHER, 1/2 NARROW	4
25	G-1100-109554	BOLT, HEX HEAD, GRADE 5, 1/2 - 20 X 5 - 1/2 LG	1
26	G-1203-1095	JAMNUT, 1/2 - 20 ELASTIC	1
27	X-1018	ASSEMBLY, HEAD	1



### Parts List

When ordering replacement parts/kits, please specify model, serial number and color of your unit.

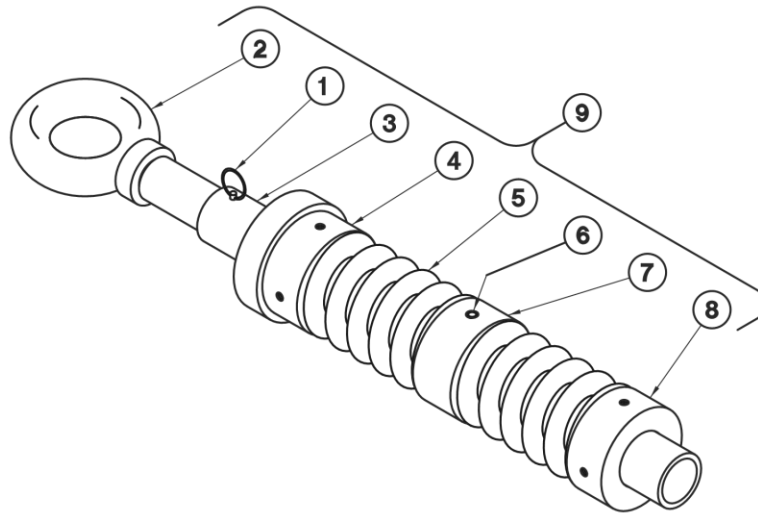

Item	Part Number	Description	Qty
7	<b>B-019-02</b>	<b>SLEEVE, CENTER</b>	1
	<b>K-1141</b>	<b>KIT, SPRING REPLACEMENT</b> ; <i>consists of:</i>	
5	B-016	SPRING	2
6	G-1322-06	PIN, DRIV-LOK GROOVE, 3/8 DIAMETER X 3-1/2 LG	1
N/S	G-1420-106006	BOLT, HEX HEAD, GRADE 8, 5/16 -18 X 3/4 LG	8
N/S	G-1251-1060R	LOCKWASHER, 5/16 REGULAR	8
	<b>K-1519</b>	<b>KIT, SHOCK ASSEMBLY REPLACEMENT</b> ; <i>consists of:</i>	
9	Z-0004	ASSEMBLY, SHOCK/SHEAR	1
N/S	G-1420-106006	BOLT, HEX HEAD, GRADE 8, 5/16 -18 X 3/4 LG	8
N/S	G-1251-1060R	LOCKWASHER, 5/16 REGULAR	8
	<b>K-1526</b>	<b>KIT, SLEEVE REPLACEMENT</b> ; <i>consists of:</i>	
4	B-018-02	SLEEVE, OUTER	1
6	G-1322-06	PIN, DRIV-LOK GROOVE, 3/8" DIAMETER X 3-1/2 LG	1
8	B-017-02	SLEEVE, INNER	1
N/S	G-1420-106006	BOLT, HEX HEAD, GRADE 8, 5/16 -18 X 3/4 LG	8
N/S	G-1251-1060R	LOCKWASHER, 5/16 REGULAR	8
	<b>K-1541</b>	<b>KIT, EYEBOLT REPLACEMENT</b> ; <i>consists of:</i>	
1	G-1307-0321	PIN, SHEAR, 3/16" DIAMETER X 2.1" LONG MODEL C	1
2	Z-1453-03	MACHINING, EYEBOLT	1
3	TR-1118-04	TUBE, OUTER SHEAR	1
6	G-1322-06	PIN, DRIV-LOK GROOVE, 3/8" DIAMETER X 3-1/2 LG	1
N/S	G-1420-106006	BOLT, HEX HEAD, GRADE 8, 5/16 -18 X 3/4 LG	8
N/S	G-1251-1060R	LOCKWASHER, 5/16 REGULAR	8
	<b>K-1696</b>	<b>KIT, SHEAR TUBE REPLACEMENT</b> ; <i>consists of:</i>	
1	G-1307-0321	PIN, SHEAR, 3/16" DIAMETER X 2.1" LG MODEL C	1
3	TR-1118-04	TUBE, OUTER SHEAR	1
6	G-1322-06	PIN, DRIV-LOK GROOVE	1
N/S	G-1420-106006	BOLT, HEX HEAD, GRADE 8, 5/16 -18 X 3/4 LG	8
N/S	G-1251-1060R	LOCKWASHER, 5/16 REGULAR	8

## Parts List

When ordering replacement parts/kits, please specify model, serial number and color of your unit.

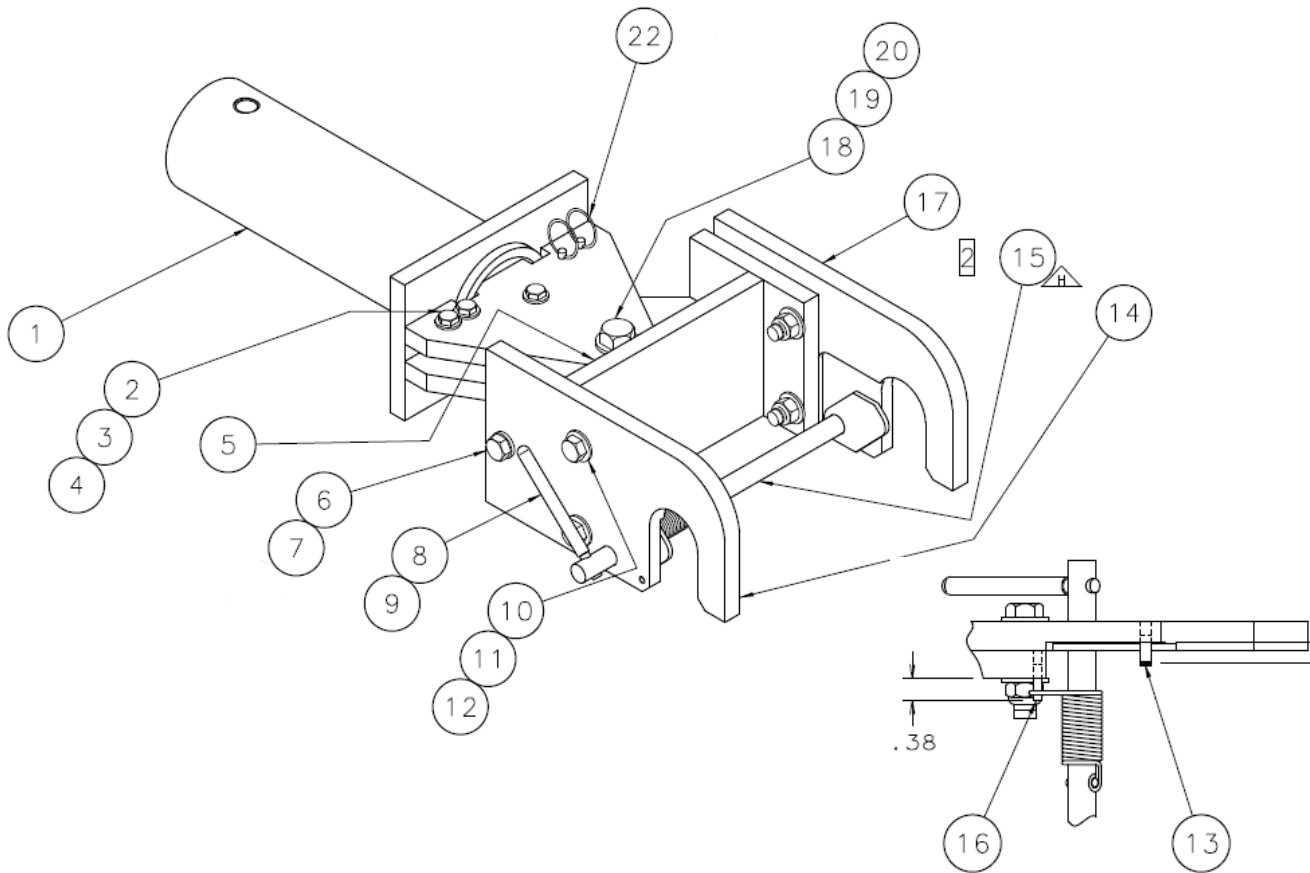

Item	Part Number	Description	Qty
22	G-1307-0321	PIN, SHEAR, 3/16 DIAMETER X 2.1 LG MODEL C	1
	<b>K-1125</b>	<b>KIT, AXLE LOCKING MECHANISM REPLACEMENT; consists of:</b>	
8	H-1205	COVER, HANDLE	1
9	G-1300-25340	PIN, ROLL, 1/4 DIAMETER X 3-1/2 LG	1
16	G-1300-16050	PIN, ROLL, 5/32" DIAMETER X 5/8 LG	2
15	Z-0019	WELDMENT, AXLE LOCKING	1
	<b>K-1445</b>	<b>KIT, HEAD SUB-ASSEMBLY REPLACEMENT; consists of:</b>	
3	G-1250-1050N	FLATWASHER, 1/4 NARROW	2
4	G-1202-1055	STOPNUT, 1/4-28 ELASTIC	1
19	G-1250-1090N	FLATWASHER, 1/2 NARROW	2
1	Z-1853-00	SHEAR PLATE	1
2	G-1110-4-20	AN BOLT, STEEL (AN 4-20)	1
18	G-1100-109524	BOLT, HEX HEAD, GRADE 5, 1/2-20 X 2-1/2 LG	1
20	G-1202-1095	STOPNUT, 1/2-20 ELASTIC	1
5	Z-0010	WELDMENT, HEAD	1
	<b>K-1446</b>	<b>KIT, SHEAR BOLT REPLACEMENT; consists of:</b>	
3	G-1250-1050N	FLATWASHER, 1/4 NARROW	2
4	G-1202-1055	STOPNUT, 1/4-28 ELASTIC	1
2	G-1110-4-20	AN BOLT, STEEL (AN 4-20)	1
	<b>K-1447</b>	<b>KIT, BUSHING REPLACEMENT; consists of:</b>	
N/S	H-1724-03	BUSHING, HEAD PRESS FIT	2
N/S	H-1725-03	BUSHING, HEADLESS	1
	<b>K-1676</b>	<b>KIT, ADAPTER SET REPLACEMENT; consists of:</b>	
6	G-1100-107510	BOLT, HEX HEAD, GRADE 5, 3/8 -24 X 1 LG	2
7	G-1251-1070R	LOCKWASHER, 3/8 REGULAR	2
10	G-1100-107516	BOLT, HEX HEAD, GRADE 5, 3/8 -24 X 1-3/4 LG	4
12	G-1202-1075	STOPNUT, 3/8 -24 ELASTIC	4
11	G-1250-1070N	FLATWASHER, 3/8 NARROW	8
13	G-1300-19040	PIN, ROLL 3/16 DIAMETER X 1/2 LG	1
14	J-2663	ADAPTER, AXLE	1
17	J-2664	ADAPTER, AXLE	1





## **APPENDIX I**

### **Declaration of Conformity**





## DECLARATION of CONFORMITY

The design, development and manufacture is in accordance with European Community guidelines

Towbar  
01-1183-0000

Relevant provisions complied with by the machinery:  
2006/42/EC

Relevant standards complied with by the machinery:  
EN ISO 12100-1

Identification of person empowered to sign on behalf of the manufacturer:

A handwritten signature in black ink that reads "Patrick Finch". The signature is written in a cursive style and is positioned above a horizontal line.

Quality Assurance Representative



**Tronair, Inc.**  
1 Air Cargo Pkwy East  
Swanton, OH 43558

Phone: (419) 866-6301 | 800-426-6301  
Web: [www.tronair.com](http://www.tronair.com)  
Email: [sales@tronair.com](mailto:sales@tronair.com)