

Model: 01-1187-0011
Custom Towbar
Saab SF-340



03/2009 – Rev. 07

For Spare Parts, Operations & Service Manuals or Service Needs
Scan the QR code or visit Tronair.com/aftermarket



REVISION	DATE	TEXT AFFECTED
05	03/2007	Added CE marking, Modified 1.1 Specifications and 3.3.2 Tug Attachment
06	06/2008	Modified Parts List
07	03/2009	Modified Parts List

TABLE OF CONTENTS

	<u>PAGE</u>
1.0 DESCRIPTION	1
1.1 SPECIFICATIONS	1
2.0 SAFETY INFORMATION	1
2.1 GENERAL	1
3.0 OPERATION	2
3.1 LANDING GEAR ASSEMBLY	2
3.2 PRELIMINARY CHECKLIST	2
3.2.1 Towbar	2
3.2.2 Towing Head	2
3.3 USAGE PROCEDURE	2
3.3.1 Aircraft Attachment	2
3.3.2 Tug Attachment	2
3.3.3 Couplers	3
3.3.4 Towing Operation	3
4.0 TRAINING	4
4.1 TRAINING REQUIREMENTS	4
4.2 TRAINING PROGRAM	4
4.3 OPERATOR TRAINING	4
5.0 PROVISION OF SPARES	4
5.1 SPARE PARTS	4
5.2 RECOMMENDED SPARE PARTS LISTS	4
6.0 IN-SERVICE SUPPORT	4
7.0 GUARANTEES/LIMITATION OF LIABILITY	4

Tronair towbars/heads must only be used with matching Tronair heads/towbars, and Tronair shear pins.

This product can not be modified without the written approval of Tronair, Inc. Any modifications done without written approval voids all warranties and releases Tronair, Inc., its suppliers, distributors, employees, or financial institutions from any liability from consequences that may occur. Only Tronair OEM replacement parts shall be used.

1.0 DESCRIPTION

The Tronair Model 01-1187-0011 custom Towbar is designed for towing Saab SF-340 Aircraft manufactured by Saab-Scania.

The custom towbar has an aircraft attachment by machined pins on the towing head to the nose landing gear tow point. There is a handle and an eyebolt at the end of the towbar for towing.

1.1 SPECIFICATIONS

Aircraft Application	Saab SF-340 Aircraft manufactured by Saab-Scania
Maximum Aircraft Gross Weight.....	29,000 lbs (13.2 Metric tons)
Length	142.187 in (361.2 cm) From eyebolt centerline to aircraft attachment centerline
Width	21.875 in (55.6 cm)
Height.....	7.75 in (19.4 cm) From ground to aircraft attachment centerline
Weight	110 lbs (49.9 kg)
Finish.....	Blue Powder Coat

2.0 SAFETY INFORMATION

2.1 GENERAL

The Tronair Model 01-1187-0011 Custom Towbar is to be used for moving the Saab SF-340 Aircraft only.

To ensure safe operation, please read the following statements and understand their meaning. This manual contains safety precautions which are explained as follows. Please read carefully.



WARNING! Warning is used to indicate the presence of a hazard that can cause **severe personal injury, death, and/or substantial property damage** if the Warning Notice is ignored.

CAUTION! Caution is used to indicate the presence of a hazard which will or can **cause minor personal injury or property damage** if the Caution Notice is ignored.



WARNING!
A damaged or bent towbar should not be used. Towbar should be repaired or replaced.

3.0 OPERATION

3.1 LANDING GEAR ASSEMBLY

Place landing gear assembly in desired location. Torque clamp nuts to 35 ft-lbs (47.5 N-m).

3.2 PRELIMINARY CHECKLIST

3.2.1 Towbar

- Check towing eye mounting bolts. Ensure fasteners are not loose or missing.
- Check towing eye for bending, excessive wear and/or deformity.
- Check shear pin. Ensure shear pin is not broken or missing; replace as required.



WARNING!

Towing an aircraft using a towbar with a broken or missing shear pin may cause damage to the aircraft.

3.2.2 Towing Head

- Check welds between side rails and head rail for cracks:
- Check welds between side rails and sliding pin wear sleeve for cracks.
- Check fastener connection of towing head to towbar. Ensure the connection is not loose or missing.
- Check sliding pin ball lok-T pins. Ensure ball lok-T pins are securely attached to the side rail via their lanyards. Ensure ball lok-T pins are not missing.
- Check sliding pins for bending or excessive wear. Ensure sliding pins slide freely.
- Check sliding pin roll pins. Ensure roll pins are not loose or missing.

3.3 USAGE PROCEDURE

3.3.1 Aircraft Attachment

- Ensure the sliding pin is locked in place using the ball lok-T pin.



CAUTION!

It is recommended that your towbar to attached to the aircraft first, and then connected to the tug to avoid possible aircraft damage.

3.3.2 Tug Attachment

- Use a pintle height so that the towbar is as level as possible during towing. Also, the pintle hook height should prevent contact of the towbar with the ground during towing.



CAUTION!

Damage to the towbar or aircraft can result from an excessive towbar angle during towing operations. Reference Figure 1.

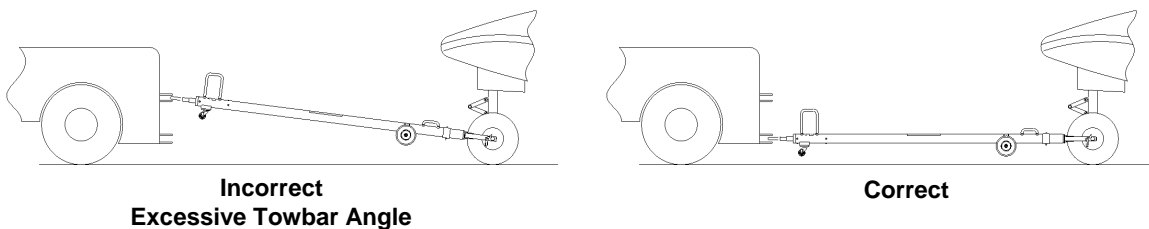

FIGURE 1



WARNING!

Towbars Should be Used with Category 1 Tugs:

Towbars should be used with category 1 tugs only in accordance with AHM 995 "Functiona1 specifications for an aircraft tractor." Using a category 2 or higher tug may result in excessive loads and stresses being applied to the towbar and/or the aircraft. These excessive loads may cause failure of the towbar which could cause damage to the aircraft or personal injury

3.3.3 Couplers



CAUTION!

Damage to the towbar or aircraft can result while towing with the following types of couplers:

- Lift Head
- Standard Duty Latch
- Vertical Side Swing Latch
- Swivel Hook

The couplers listed above are known to cause binding and failure in the eyebolt. Indicators of binding are wear on outside diameter of the eyebolt and indentation on the inside diameter of the eyebolt. **Reference Figure 2.**

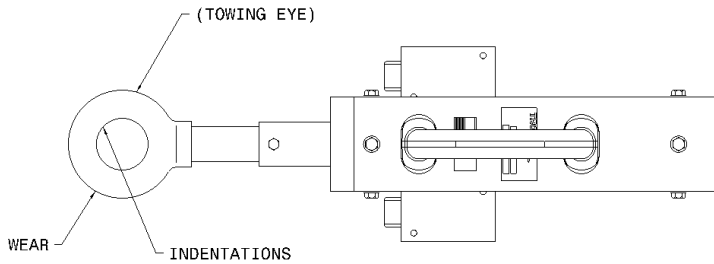

FIGURE 2

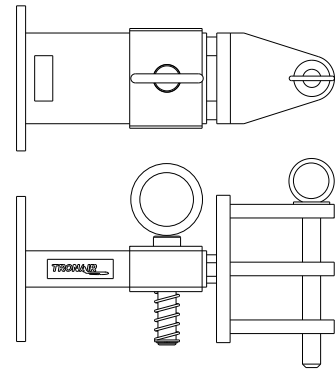

FIGURE 3
01-1950-5000 Standard Telecoupler

Tronair recommends a telecoupler pintle hook arrangement. This arrangement is known to eliminate binding. Tronair offers a Standard Telecoupler, Model Number 01-1950-5000, for use on tugs. **Reference Figure 3.**

Damage to the towbar and/or aircraft can result by towing or pushing an aircraft with an incorrect size eyebolt or pintle pin. A correct size eyebolt will make contact with the pintle pin. A gap between the eyebolt outside diameter and the coupler face plate should be easily seen. An eyebolt which is too large will cause the eyebolt to make contact with the face plate of the coupler. When the eyebolt is too large for the coupler, a gap between the inside diameter of the eyebolt and the coupler face plate will be seen. **Reference Figure 4.**

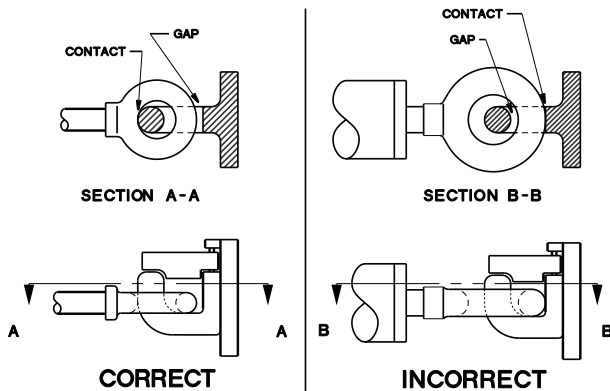

FIGURE 4

To ensure proper towing and pushing, check to make sure the pintle pin diameter is not too long for the eyebolt's inside diameter. An approximate one-half inch ($\frac{1}{2}$ ") gap between the pin diameter and the eyebolt should be seen. If any of these conditions are not met, please contact Tronair for information to obtain a new coupler.

3.3.4 Towing Operation

Damage to the towbar or aircraft can result from pushing an aircraft while maintaining too sharp of an angle between the tug and the aircraft. Contact between the towbar weldment and the tug must be avoided. It is recommended that the angle between the tug and towbar not exceed 90°.

Reference Figure 5

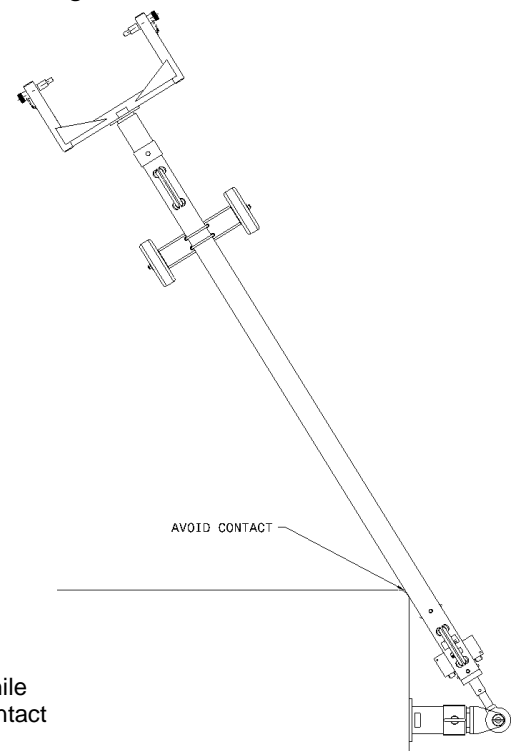

FIGURE 5

4.0 TRAINING

4.1 TRAINING REQUIREMENTS

The employer of the operator is responsible for providing a training program sufficient for the safe operation of the towbar.

4.2 TRAINING PROGRAM

The employer provided operator training program should cover safety procedures concerning use of the towbar in and around the aircraft at the servicing location.

4.3 OPERATOR TRAINING

The operator training should provide the required training for safe operation of the towbar.

NOTE: Maintenance and Trouble Shooting are to be performed by the skilled and trained technician.

5.0 PROVISION OF SPARES

5.1 SPARE PARTS

When ordering Replacement Parts/Kits & Spare Parts, please specify Model & Serial Number of your product.

Spare parts may be obtained from the manufacturer:

TRONAIR , Inc.	Telephone: (419) 866-6301 or 800-426-6301
1 Air Cargo Pkwy East	Fax: (419) 867-0634
Swanton, Ohio 43558 USA	E-mail: sales@tronair.com
	Website: www.tronair.com

For Spare Parts, Operations & Service Manuals or Service Needs:
Scan the QR code or visit Tronair.com/aftermarket



5.2 RECOMMENDED SPARE PARTS LISTS

Recommended Spares to be kept on hand:
K-1112.....Kit, Wheel Replacement (Single)
K-1114.....Kit, Caster Replacement (Set)
K-1308.....Kit, Ball Loc Pin Replacement
K-1347.....Kit, Sliding Pin Replacement

6.0 IN-SERVICE SUPPORT

Contact Tronair for technical services and information.

7.0 GUARANTEES/LIMITATION OF LIABILITY

Tronair products are warranted to be free of manufacturing or material defects for a period of one year after shipment to the original customer. This is solely limited to the repair or replacement of defective components. This warranty does not cover the following items:

- Parts required for normal maintenance
- Parts covered by a component manufacturers warranty
- Replacement parts have a 90-day warranty from date of shipment

If you have a problem that may require service, contact Tronair immediately. Do not attempt to repair or disassemble a product without first contacting Tronair, any action may affect warranty coverage. When you contact Tronair be prepared to provide the following information:

- Product Model Number
- Product Serial Number
- Description of the problem

If warranty coverage is approved, either replacement parts will be sent or the product will have to be returned to Tronair for repairs. If the product is to be returned, a Return Material Authorization (RMA) number will be issued for reference purposes on any shipping documents. Failure to obtain a RMA in advance of returning an item will result in a service fee. A decision on the extent of warranty coverage on returned products is reserved pending inspection at Tronair. Any shipments to Tronair must be shipped freight prepaid. Freight costs on shipments to customers will be paid by Tronair on any warranty claims only. Any unauthorized modification of the Tronair products or use of the Tronair products in violation of cautions and warnings in any manual (including updates) or safety bulletins published or delivered by Tronair will immediately void any warranty, express or implied.

The obligations of Tronair expressly stated herein are in lieu of all other warranties or conditions expressed or implied. **Any unauthorized modification of the Tronair products or use of the Tronair products in violations of cautions and warnings in any manual (including updates) or safety bulletins published or delivered by Tronair will immediately void any warranty, express or implied and Tronair disclaims any and all liability for injury (WITHOUT LIMITATION and including DEATH), loss or damage arising from or relating to such misuse.**

Parts List

When ordering replacement parts/kits, please specify model, serial number and color of your unit.

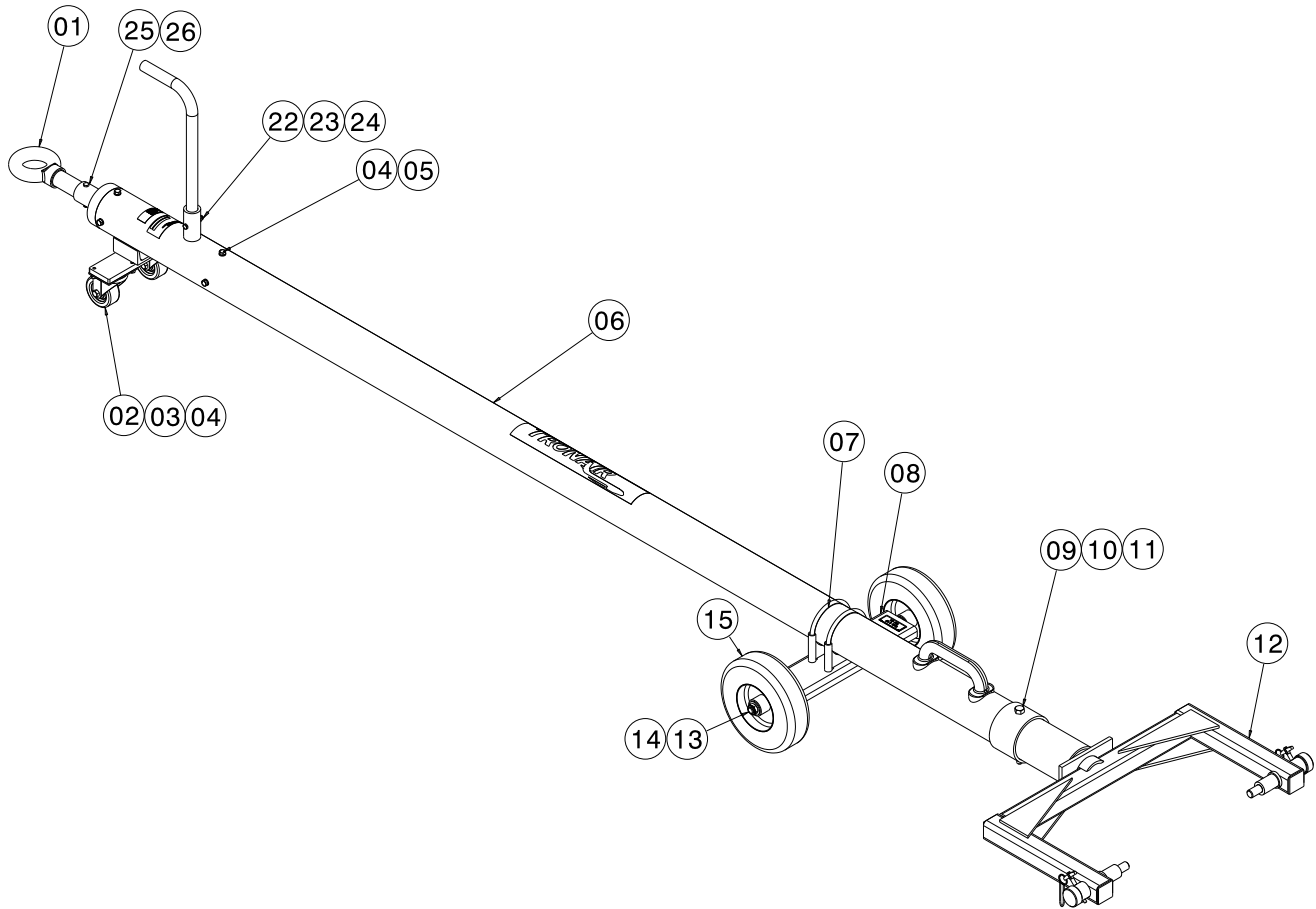

Item	Part Number	Description	Qty
1	Z-1904-01	Assembly, Shock Shear	1
2	U-1000	Caster, Swivel	2
3	G-1100-106005	Bolt, Hex Head, Grade 5, 5/16-18 x 5/8" long	4
4	G-1251-1060R	Lockwasher, 5/16 Regular	12
5	G-1420-106006	Bolt, Hex Head, Grade 8, 5/16-18 x 3/4" long	8
6	Z-5945-01	Machining, Towbar	1
7	H-1537-08	Clamp, Muffler	2
8	Z-5643-01	Weldment, Axle Mounting	1
9	G-1100-109544	Bolt, Hex Head, Grade 5, 1/2-20 x 4 1/2" long	1
10	G-1250-1090N	Flatwasher, 1/2 Narrow	1
11	G-1203-1095	Jamnut, 1/2-20 Elastic	1
12	X-1117 (See Page 7)	Assembly, Head	1
13	G-1203-1105	Jamnut, 5/8-18 Elastic	1
14	G-1250-1100N	Flatwasher, 5/8 Narrow	1
15	U-1024	Wheel, Pneumatic Tire	1
22	G-1100-05520	Bolt, 1/4 - 28 Hex HD Grade 5	1
23	G-1250-1050N	Flatwasher, 1/4 Narrow	1
24	G-1202-1055	Stopnut, 1/4 - 28 Elastic	1
25	G-1110-4-22A	Belt, AN 1/4 - 28 NF-3 x 2 9/32" long	1
26	G-1202-1055	ESN, 1/4 - 28	1

Parts List

When ordering replacement parts/kits, please specify model, serial number and color of your unit.

Item	Part Number	Description	Qty
	K-1112	Kit, Wheel (Single) Replacement; consists of:	
13	G-1203-1105	Jamnut, 5/8-18 Elastic	1
14	G-1250-1100N	Flatwasher, 5/8 Narrow	1
15	U-1024	Wheel, Pneumatic Tire	1
	K-1114	Kit, Caster (Set) Replacement; consists of:	
2	U-1000	Caster, Swivel	2
3	G-1100-106005	Bolt, Hex Head, Grade 5, 5/16-18 x 5/8" long	4
4	G-1251-1060R	Lockwasher, 5/16 Regular	4
	K-1521	Kit, Shock/Shear Assembly; consists of:	
1	Z-1904-01	Assembly, Shock Shear	1
4	G-1251-1060R	Lockwasher, 5/16 Regular	8
5	G-1420-106006	Bolt, Hex Head, Grade 8, 5/16-18 x 3/4" long	8
	K-4124	Kit, Landing Gear Replacement; consists of:	
7	H-1537-08	Clamp, Muffler	2
8	Z-5643-01	Weldment, Axle Mounting	1
13	G-1203-1105	Jamnut, 5/8-18 Elastic	2
14	G-1250-1100N	Flatwasher, 5/8 Narrow	4
15	U-1024	Wheel, Pneumatic Tire	2
	K-4315	Kit, Towbar Tube Replacement; consists of:	
6	Z-5945-01	Machining, Towbar	1

Parts List

When ordering replacement parts/kits, please specify model, serial number and color of your unit.

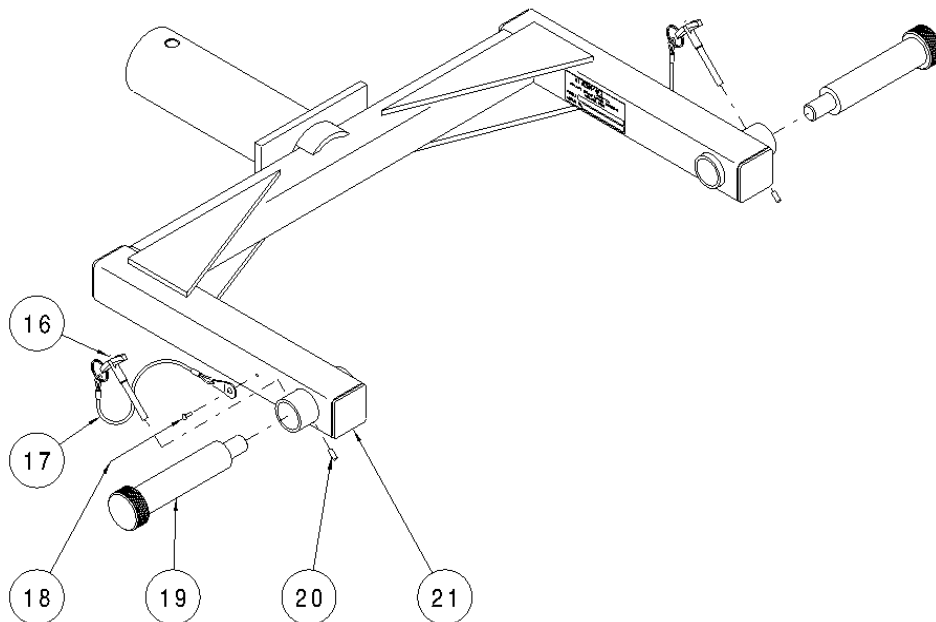

Item	Part Number	Description	Qty
21	Z-5216-01	Weldment, Head	1
	K-1308	Kit, Ball Lok-T Pin Replacement; consists of:	
16	G-1310-0415	Pin, Ball Lok-T, 1/4" diameter x 1 1/2" long	1
17	H-1026*07.0	Assembly, Lanyard	1
18	G-1351-04	Rivet, 1/8 Open-End Steel	1
	K-1347	Kit, Sliding Pin Replacement; consists of:	
19	R-1154	Pin, Sliding	1
20	G-1300-19040	Pin, Roll, 3/16" diameter x 1/2" long	1



APPENDIX I

Declaration of Conformity



DECLARATION of CONFORMITY

The design, development and manufacture is in accordance with European Community guidelines

Custom Towbar
01-1187-0011

Relevant provisions complied with by the machinery:
2006/42/EC

Relevant standards complied with by the machinery:
EN ISO 12100-1

Identification of person empowered to sign on behalf of the Manufacturer:

A handwritten signature in cursive script that reads "Patrick Finch". The signature is written in black ink and is positioned above a horizontal line.

Quality Assurance Representative