

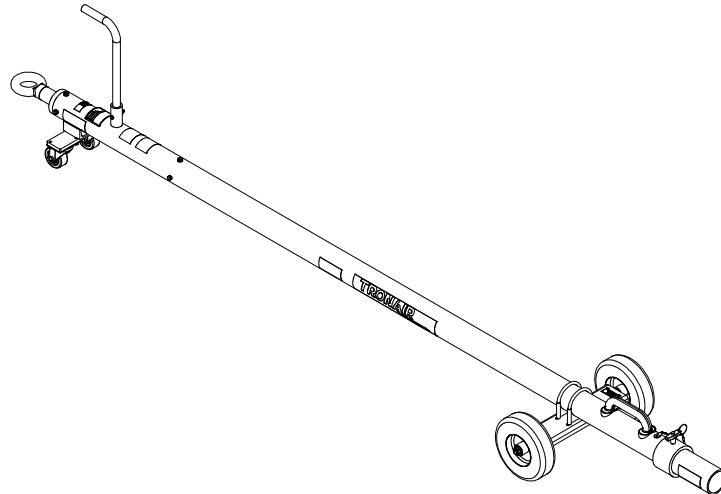

## Operation & Service Manual



**Model: 01-1202-0000**  
**Multi-Head Towbar**



11/2006 - Rev. 17

**Includes Illustrated Parts List**

### ***Tronair, Inc.***

1740 Eber Road  
Holland, Ohio 43528-9794  
USA

Telephone: (419) 866-6301 • 800-426-6301

Fax: (419) 867-0634

Web Site: [www.tronair.com](http://www.tronair.com) E-mail: [sales@tronair.com](mailto:sales@tronair.com)



**TABLE OF CONTENTS**

**PAGE**

1.0	Description .....	1
1.1	Specifications .....	1
2.0	Safety Information .....	1
2.1	General .....	1
3.0	Operation.....	1
3.1	Landing Gear Assembly .....	1
3.2	Towbar Checklist .....	1
3.3	Usage Procedure.....	2
3.3.1	Aircraft Attachment.....	2
3.3.2	Tug Attachment.....	2
3.3.3	Couplers .....	3
3.2.4	Towing Operation.....	4
4.0	Training .....	4
4.1	Training Requirements .....	4
4.2	Training Program.....	4
4.3	Operator Training .....	4
5.0	Provision Of Spares .....	4
5.1	Spare Parts.....	4
5.2	Parts List.....	4
6.0	In-Service Support.....	4
7.0	Guarantees.....	5

Appendix I Declaration of Conformity

**Model: 01-1202-0000**  
**Multi-Head Towbar**

<b>REVISION</b>	<b>DATE</b>	<b>TEXT AFFECTED</b>
15	12/2003	pg 2 3.2 Warning added
16	11/2004	pg 1 Modified 3.2 Towbar Checklist
17	11/2006	Added CE standards

**Model: 01-1202-0000  
Multi-Head Towbar**

Tronair towbars/heads must only be used with matching Tronair heads/towbars, and Tronair shear pins.

This product can not be modified without the written approval of Tronair, Inc. Any modifications done without written approval voids all warranties and releases Tronair, Inc., its suppliers, distributors, employees, or financial institutions from any liability from consequences that may occur. Only Tronair OEM replacement parts shall be used.

## 1.0 DESCRIPTION

The Tronair Model 01-1202-0000 Multi-Head Towbar is a lightweight, multi-aircraft towbar for use with the Tronair Series 500 Multi-Heads.

The multi-head towbar includes pneumatic tires in addition to casters at the tug end. There is an eyebolt at the towing end of the towbar which incorporates a spring to dampen shock loads.

### 1.1 SPECIFICATIONS

<b>Application:</b>	Designed for use with Tronair Series 500 Multi-Heads
<b>Maximum Aircraft Gross Weight:</b>	66,000 lbs (29.9 Metric ton)
<b>Dimensions:</b>	Length 126 <sup>5</sup> / <sub>32</sub> in (320.4 cm) From eyebolt centerline to end of towbar. Width 21 <sup>7</sup> / <sub>8</sub> in (55.6 cm) Height 7 <sup>5</sup> / <sub>16</sub> in (18.6 cm) From ground to towbar tube centerline. Tube 3 <sup>1</sup> / <sub>2</sub> in (8.9 cm) diameter
<b>Weight:</b>	92 lbs (41.7 kg)
<b>Finish:</b>	Powder Coat
<b>Material:</b>	Aluminum

## 2.0 SAFETY INFORMATION

### 2.1 GENERAL

The Tronair Model 01-1202-0000 Multi-Head Towbar is used with the Tronair Series 500 Multi-Heads for moving aircraft only.

To ensure safe operation, please read the following statements and understand their meaning. This manual contains safety precautions which are explained as follows. Please read carefully.



**WARNING!** Warning is used to indicate the presence of a hazard that can cause **severe personal injury, death, and/or substantial property damage** if the Warning Notice is ignored.

**CAUTION!** Caution is used to indicate the presence of a hazard which will or can cause **minor personal injury or property damage** if the Caution Notice is ignored.

## 3.0 OPERATION

### 3.1 LANDING GEAR ASSEMBLY

Place landing gear assembly in desired location. Torque clamp nuts to 35 ft-lbs (47.5 N-m)

### 3.2 TOWBAR CHECKLIST

- Check towing eye for bending, excessive wear and/or deformity. Contact Tronair for repair/replacement if towing eye is bent, excessively worn or deformed.
- Check towing eye mounting bolts. Ensure fasteners are not loose or missing. Tighten to 25 ft-lbs or replace as required.
- Ensure that the towing eye does not turn; if the towing eye can turn it indicates that the centering pin within the shock assembly may have been broken and repairs are needed.
- Check the shock assembly for preload on the spring by pulling on the towing eye. If the shock can be moved by hand it indicates that the spring is worn out and Tronair should be contacted for repairs.

3.2 Towbar checklist continued on following page.

**TRONAIR**

11/2006 – Rev. 17

- 1 -

### 3.2 TOWBAR CHECKLIST *(continued)*

- Inspect the towbar tube for cracks, gouges greater than 1/16 inch, and bends or deformities. A damaged or bent towbar should not be used. Contact Tronair for replacement.
- Check the casters to ensure the swivels operate freely and the bearings are not missing. Replace if needed.
- Ensure that the caster mounting fasteners are not loose or missing. Tighten or replace as required.
- Check the caster mounting plate and channel. If the caster mounting plate is bent or broken or if the channel welds are broken, contact Tronair for repairs.
- Inspect the lifting handle at the towing eye end. Replace or repair the handle if it is missing or damaged. Ensure the mounting fasteners are not loose or missing. Tighten or replace as required.
- Check the towbar undercarriage. Inflate the pneumatic tires to the proper pressure; fix any air leaks or replace if needed, ensure the wheels can rotate freely, wheel rims are not bent, and tire axle is not bent. Ensure mounting fasteners are not loose or missing; tighten or replace as required. Grease the tire axle every 90 days to 6 months.
- Inspect towing head attachment ball loc pin. Verify that the factory supplied ball loc pin is used; contact Tronair for replacement if required. Do not substitute without Tronair approval.



#### WARNING!

A damaged or bent towbar should not be used. Towbar should be repaired or replaced.

#### WARNING!



Towbars should be used with category 1 tugs ONLY in accordance with AHM 995 "Functional specifications for an aircraft tractor" Using a category 2 or higher tug may result in excessive loads and stresses being applied to the towbar and/or the aircraft. These excessive loads may cause failure of the towbar which could cause damage to the aircraft or personal injury.

### 3.3 USAGE PROCEDURE

#### 3.3.1 Aircraft Attachment



#### CAUTION!

It is recommended that your towbar to attached to the aircraft first, and then connected to the tug to avoid possible aircraft damage.

#### 3.3.2 Tug Attachment



#### CAUTION!

Damage to the towbar or aircraft can result from an excessive towbar angle during towing operations. *Reference Figure 1.*

- Use a pintle height so that the towbar is as level as possible during towing. Also, the pintle hook height should prevent contact of the towbar with the ground during towing.

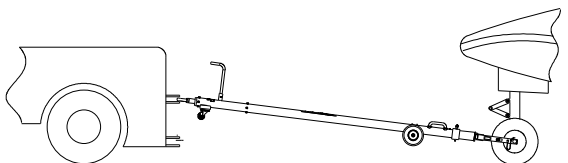

**Incorrect**  
**(Excessive Towbar Angle)**

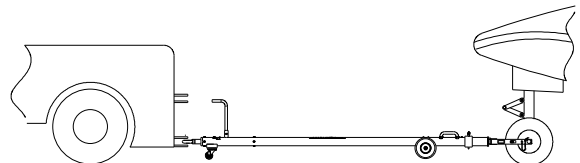

**Correct**

**FIGURE 1**

3.3 USAGE PROCEDURE (continued)

3.3.3 Couplers

**CAUTION!**



Damage to the towbar or aircraft can result while towing with the following types of couplers:

- Lift Head
- Vertical Side Swing Latch
- Standard Duty Latch
- Swivel Hook

The couplers listed above are known to cause binding and failure in the lunette eye. Indicators of binding are wear on outside diameter of the eyebolt and indentation on the inside diameter of the eyebolt. **Reference Figure 2.**

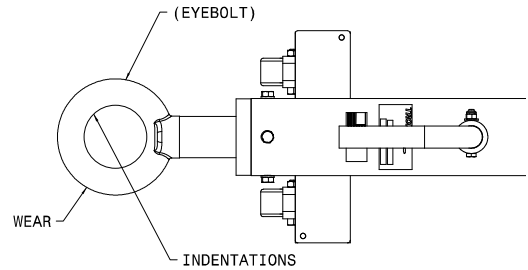
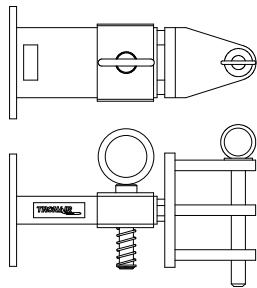

**FIGURE 2**

Tronair recommends a telecoupler pintle hook arrangement. This arrangement is known to eliminate binding. Tronair offers a Standard Telecoupler, Model Number 01-1950-5000, for use on tugs. **Reference Figure 3.**

Damage to the towbar and/or aircraft can result by towing or pushing an aircraft with an incorrect size eyebolt or pintle pin. A correct size eyebolt will make contact with the pintle pin. A gap between the eyebolt outside diameter and the coupler face plate should be easily seen. An eyebolt which is too large will cause the eyebolt to make contact with the face plate of the coupler. When the eyebolt is too large for the coupler, a gap between the inside diameter of the eyebolt and the coupler face plate will be seen. **Reference Figure 4.**

To ensure proper towing and pushing, check to make sure the pintle pin diameter is not too long for the eyebolt's inside diameter. An approximate one-half inch ( $\frac{1}{2}$ " ) gap between the pin diameter and the eyebolt should be seen. If any of these conditions are not met, please contact Tronair for information to obtain a new coupler.



**FIGURE 3**  
01-1950-5000 Standard Telecoupler

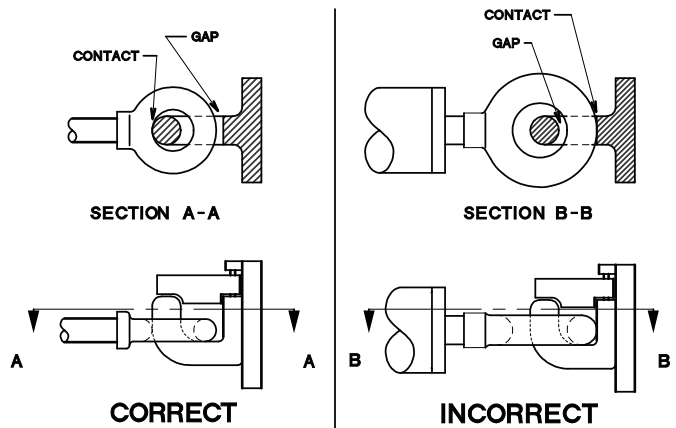

**FIGURE 4**

3.3 Usage Procedure continued on following page.

3.3 USAGE PROCEDURE (*continued*)

3.2.4 Towing Operation

Damage to the towbar or aircraft can result from pushing an aircraft while maintaining too sharp of an angle between the tug and the aircraft. Contact between the towbar weldment and the tug must be avoided. It is recommended that the angle between the tug and towbar not exceed 90°. **Reference Figure 5.**

4.0 TRAINING

4.1 TRAINING REQUIREMENTS

The employer of the operator is responsible for providing a training program sufficient for the safe operation of the towbar.

4.2 TRAINING PROGRAM

The employer provided operator training program should cover safety procedures concerning use of the towbar in and around the aircraft at the servicing location.

4.3 OPERATOR TRAINING

The operator training should provide the required training for safe operation of the towbar.

**NOTE:** *Maintenance and Trouble Shooting are to be performed by the skilled and trained technician.*

5.0 PROVISION OF SPARES

5.1 SPARE PARTS

Spare parts may be obtained from the manufacturer:

**TRONAIR, INC.**  
1740 Eber Road  
Holland, Ohio 43528-9794 USA

Telephone: 419-866-6301  
Fax: 419-867-0634  
E-mail Address: sales@tronair.com  
www.tronair.com

5.2 PARTS LIST

Reference Pages 6 & 7 for ordering information of Replacement Parts and Kits.

6.0 IN-SERVICE SUPPORT

Contact Tronair for technical services and information.

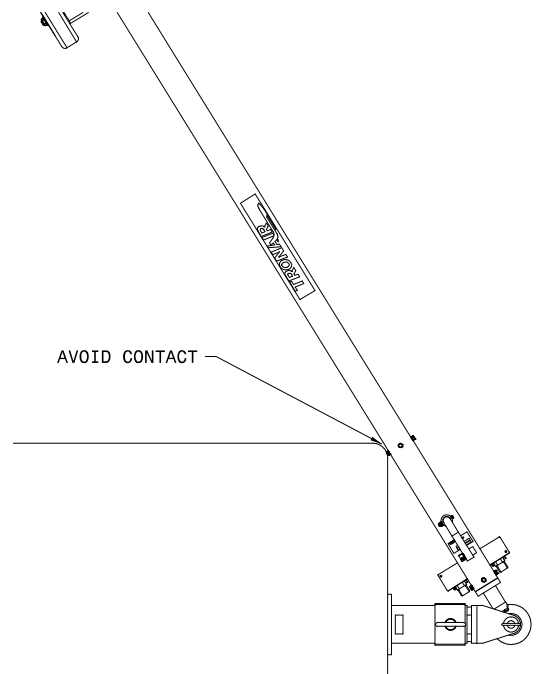

FIGURE 5



## **7.0 GUARANTEES**

Tronair products are warranted to be free of manufacturing or material defects for a period of one year after shipment to the original customer. This is solely limited to the repair or replacement of defective components. This warranty does not cover the following items:

- a) Parts required for normal maintenance
- b) Parts covered by a component manufacturers warranty
- c) Replacement parts have a 90-day warranty from date of shipment

If you have a problem that may require service, contact Tronair immediately. Do not attempt to repair or disassemble a product without first contacting Tronair, any action may affect warranty coverage. When you contact Tronair be prepared to provide the following information:

- a) Product Model Number
- b) Product Serial Number
- c) Description of the problem

If warranty coverage is approved, either replacement parts will be sent or the product will have to be returned to Tronair for repairs. If the product is to be returned, a Return Material Authorization (RMA) number will be issued for reference purposes on any shipping documents. Failure to obtain a RMA in advance of returning an item will result in a service fee. A decision on the extent of warranty coverage on returned products is reserved pending inspection at Tronair. Any shipments to Tronair must be shipped freight prepaid. Freight costs on shipments to customers will be paid by Tronair on any warranty claims only. Any unauthorized modification of the Tronair products or use of the Tronair products in violation of cautions and warnings in any manual (including updates) or safety bulletins published or delivered by Tronair will immediately void any warranty, express or implied.

The obligations of Tronair expressly stated herein are in lieu of all other warranties or conditions expressed or implied. Without limitation, to the fullest extent allowable by law, this exclusion of all other warranties and conditions extends to implied warranties and conditions of satisfactory quality, merchantable quality, and fitness for a particular purpose, and those arising by statute or otherwise in law, or from a course of dealing or usage of trade.

## Parts List

When ordering Replacement Parts/Kits, please specify Model & Serial Number of your product.

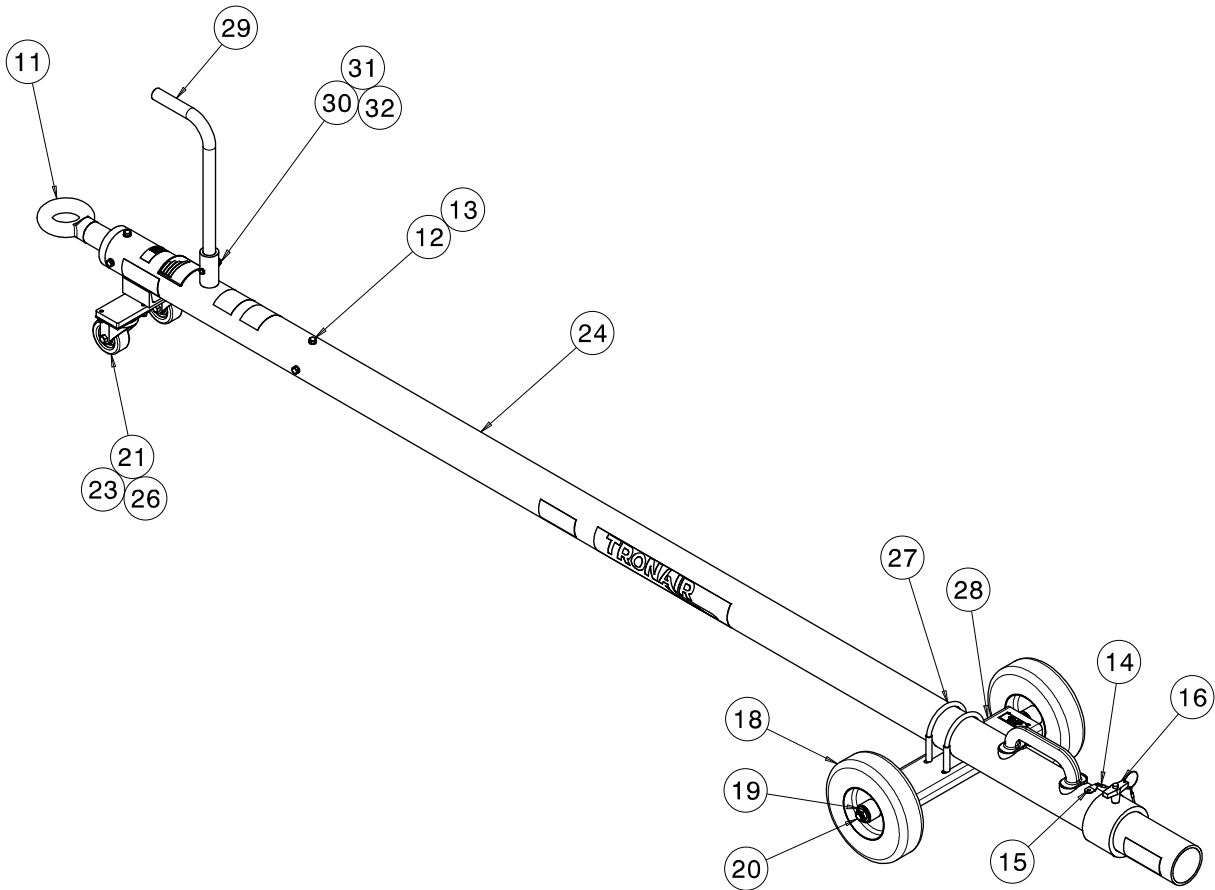

ITEM	PART NUMBER	DESCRIPTION	QTY
<i>Item 11 Shock Assembly consists of Items 1 – 10 which are not sold separately.</i>			
14	H-1026*12.0	Assembly, Lanyard	1
15	G-1351-04	Rivet, 1/8" diameter x 1/4" long	1
16	G-1310-0848	Pin, Ball Lok-T, 1/2" diameter x 4.8" grip length	1
21	U-1000	Caster	2
▶ 23	G-1100-106004	Bolt, Hex Head, Grade 5, 5/16 -18 x 1/2" long	4
24	Z-5645-01	Machining, Towbar	1
26	G-1250-1060N	Flatwasher, 5/16 Narrow	4
27	H-1537-07	Clamp, Muffer	2
28	Z-5643-01	Weldment, Axle Mounting	1

## Parts List

When ordering Replacement Parts/Kits, please specify Model & Serial Number of your product.

Reference Illustration on previous page.

ITEM	PART NUMBER	DESCRIPTION	QTY
29	TR-1857-01	Tube, Handle	1
30	G-1100-105520	Bolt, Hex Head, Grade 5, 1/4-28 x 2" long	1
31	G-1202-1055	Stopnut, 1/4-28 Elastic	1
32	G-1250-1050N	Flatwasher, 1/4 Narrow	1
	<b>K-1112</b>	<b>Kit, Wheel (Single) Replacement; consists of:</b>	
18	U-1024	Wheel	1
19	G-1250-1100N	Flatwasher, 5/8 Narrow	1
▶ 20	G-1203-1105	Jamnut, 5/8 -18 Elastic	1
	<b>◆ K-1460</b>	<b>Kit, Shock Assembly Replacement; consists of:</b>	
11	Z-1895	Assembly, Shock	1
12	G-1251-1060R	Lockwasher, 5/16 Regular	8
▶ 13	G-1420-106006	Bolt, Hex Head, Grade 8, 5/16 -18 x 3/4" long	8

▶ Use Loctite 271 or equivalent during re-assembly.

◆ Due to the high compression used in assembly, it is suggested this Shock Assembly be returned to Tronair for repair. Discuss with your Salesperson.





## **APPENDIX - I**

### **Declaration of Conformity**





## DECLARATION of CONFORMITY

The design, development and manufacture is in accordance with European Community guidelines

Multi-Head Towbar  
01-1202-0000

Relevant provisions complied with by the machinery:  
98/37/EC

Relevant standards complied with by the machinery:

EN ISO 12100-1

Identification of person empowered to sign on behalf of the manufacturer:

A handwritten signature in black ink that reads "David L. Kiehl". The signature is written in a cursive style and is positioned above a horizontal line.

Quality Assurance Representative

### **Tronair, Inc.**

1740 Eber Road  
Holland, Ohio 43528-9794  
USA

Telephone: (419) 866-6301 • 800-426-6301

Fax: (419) 867-0634

Web Site: [www.tronair.com](http://www.tronair.com) E-mail: [sales@tronair.com](mailto:sales@tronair.com)





# Towbar Checklist

## Universal Multi-Head Towbar

Models: 01-1201-0010, 01-1201-0011, 01-1202-0000



### Tronair recommends towbar inspections at least once a week.

- Check towing eye for bending, excessive wear and deformity. If any are located, remove towbar from service and contact Tronair for repair.
- Check towing eye mounting bolts. Ensure the fasteners are tight and not missing. Tighten to 25 ft-lbs or replace as required.
- Ensure the towing eye does not move or turn by hand; if the towing eye can turn this may indicate that the centering pin within the shock assembly may be broken, contact Tronair for repairs.
- Check the shock assembly for preload on the spring by pulling on the towing eye. If the shock can be moved by hand this may indicate the spring is worn out, contact Tronair for repairs.
- Inspect the towbar tube for cracks, gouges greater than 1/16", and bends or deformities. If any are located, remove towbar from service and contact Tronair for repair.
- Check casters for damage; ensure the swivels operate freely and the bearings are not missing. Replace if needed.
- Ensure the caster mounting fasteners are tight and not missing. Tighten or replace as required.
- Check the caster mounting plate and channel for bends or breaks. If any are located, remove towbar from service and contact Tronair for repair. Inspect welds, contact Tronair if repairs are needed.
- Inspect the front and rear lifting handles. Repair or replace the handle if it is missing or damaged. Inspect the welds, contact Tronair if repairs are needed. Ensure the mounting fasteners are tight and not missing. Tighten or replace as required.
- Check the towbar undercarriage for unusual wear or damage. Inflate the pneumatic tires to the proper pressure; repair any air leaks or replace if needed. Ensure the wheels can rotate freely, and wheel rims and tire axle are not bent. Ensure mounting fasteners are tight and not missing. Tighten or replace as required. Torque U-bolt nuts to 35 ft-lbs. Grease tire axle every 90 days.
- Inspect towing head attachment ball-lok pin for bending or unusual wear. Verify the factory supplied pin is used. Contact Tronair or your Tronair distributor for replacement if required. Use only Tronair specified ball-lok pins.
- Ensure the pin is connected to the towbar via its lanyard. Replace lanyard if missing.
- Inspect all steel components for signs of rust. Touch up with paint as required.

INS-1785 -- 09/2004

## TRONAIR

Tronair, Inc., 1740 Eber Road  
Holland, Ohio 43528-9794, USA  
Telephone: (419) 866-6301 • 800-426-6301  
Fax: (419) 867-0634  
Web Site: [www.tronair.com](http://www.tronair.com)  
E-mail: [sales@tronair.com](mailto:sales@tronair.com)