

Model: 01-1239-0000 Lear Portable Handling Towbar



04/2023 - Rev. 03

**For Spare Parts, Operations & Service Manuals or Service Needs
Scan the QR code or visit Tronair.com/aftermarket**



REVISION
03

DATE
04/2023

TEXT AFFECTED
Major revision

TABLE OF CONTENTS

PAGE

1.0	PRODUCT INFORMATION	1
1.1	DESCRIPTION.....	1
1.2	MODEL & SERIAL NUMBER.....	1
1.3	MANUFACTURER	1
2.0	SAFETY INFORMATION	1
2.1	USAGE AND SAFETY INFORMATION	1
3.0	TRAINING	1
3.1	TRAINING REQUIREMENTS	1
3.2	TRAINING PROGRAM	1
3.3	OPERATOR TRAINING	1
4.0	OPERATION	2
4.1	TOWBAR CHECKLIST	2
4.2	USAGE PROCEDURE.....	2
4.2.1	Aircraft Attachment.....	2
4.2.2	Tug Attachment.....	2
4.2.3	Couplers.....	3
4.2.4	Towing Operation.....	3
5.0	PROVISION OF SPARES	4
5.1	SOURCE OF SPARE PARTS.....	4
5.2	RECOMMENDED SPARE PARTS LISTS	4
6.0	IN SERVICE SUPPORT	4
7.0	GUARANTEES/LIMITATION OF LIABILITY	4

Tronair towbars/heads must only be used with matching Tronair heads/towbars, and Tronair shear pins.

This product cannot be modified without the written approval of Tronair, Inc. Any modifications done without written approval voids all warranties and releases Tronair, Inc., its suppliers, distributors, employees, or financial institutions from any liability from consequences that may occur. Only Tronair OEM replacement parts shall be used.

1.0 PRODUCT INFORMATION

1.1 DESCRIPTION

Tronair 01-1239-0000 is a portable handling towbar designed for towing Lear aircraft.

1.2 MODEL & SERIAL NUMBER

Reference nameplate on unit

1.3 MANUFACTURER

TRONAIR, Inc.
1 Air Cargo Pkwy East
Swanton, Ohio 43558 USA

Telephone: (419) 866-6301 or 800-426-6301
Fax: (419) 867-0634
E-mail: sales@tronair.com
Website: www.tronair.com

2.0 SAFETY INFORMATION

2.1 USAGE AND SAFETY INFORMATION

To insure safe operations please read the following statements and understand their meaning. Also refer to your equipment manufacturer's manual for other important safety information. This manual contains safety precautions which are explained below. Please read carefully.



WARNING!

Warning is used to indicate the presence of a hazard that can cause **severe personal injury, death, and/or substantial property damage** if the Warning Notice is ignored.



CAUTION!

Caution is used to indicate the presence of a hazard, which will or can cause **minor personal injury or property damage** if the Caution Notice is ignored.

3.0 TRAINING

3.1 TRAINING REQUIREMENTS

The employer of the operator is responsible for providing a training program sufficient for the safe operation of the unit.

3.2 TRAINING PROGRAM

The employer provided operator training program should cover safety procedures concerning use of the unit in and around the intended aircraft at the intended aircraft servicing location.

3.3 OPERATOR TRAINING

The operator training should provide the required training for safe operation of the unit.

NOTE: Maintenance and Trouble Shooting are to be performed by a skilled and trained technician.

4.0 OPERATION

Your Tronair towbar is engineered and built to the highest standards of quality and workmanship. Under normal usage and with minimal maintenance this towbar will provide exceptional service.

4.1 TOWBAR CHECKLIST

- Check towing eye for bending, excessive wear and/or deformity. Contact Tronair for repair/replacement if towing eye is bent, excessively worn or deformed.
- Check towing eye mounting bolts. Ensure fasteners are not loose or missing. Tighten to 25 ft-lbs or replace as required.
- Ensure that the towing eye does not turn; if the towing eye can turn it indicates that the centering pin within the shock assembly may have been broken and repairs are needed.
- Inspect the towbar tube for cracks, gouges greater than 1/16 inch, and bends or deformities. A damaged or bent towbar should not be used. Contact Tronair for replacement.
- Inspect towing head attachment ball loc pin. Verify that the factory supplied ball loc pin is used; contact Tronair for replacement if required. Do not substitute without Tronair approval.



WARNING!

A damaged or bent towbar should not be used, but should be repaired or replaced.

Using a damaged or bent towbar can result in aircraft or equipment damage and possible personal injury.

4.2 USAGE PROCEDURE

4.2.1 Aircraft Attachment



CAUTION!

It is recommended that your towbar be attached to the aircraft first, and then connected to the tug to avoid possible aircraft damage.

4.2.2 Tug Attachment



CAUTION!

Damage to the towbar or aircraft can result from an excessive towbar angle during towing operations. Reference Figure 1.

- Use a pintle height so that the towbar is as level as possible during towing. Also, the pintle hook height should prevent contact of the towbar with the ground during towing.

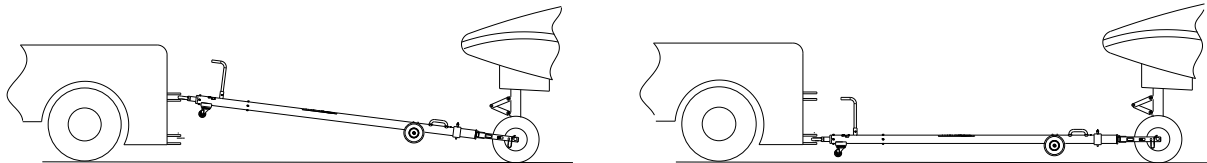

**Incorrect
(Excessive Towbar Angle)**

Correct

FIGURE 1

4.2.3 Couplers

CAUTION!



Damage to the towbar or aircraft can result while towing with the following types of couplers:

- Lift Head
- Vertical Side Swing Latch
- Standard Duty Latch
- Swivel Hook

The couplers listed above are known to cause binding and failure in the lunette eye. Indicators of binding are wear on outside diameter of the eyebolt and indentation on the inside diameter of the eyebolt. **Reference Figure 2.**

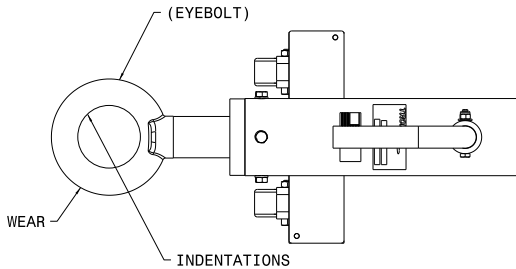

FIGURE 2

Tronair recommends a telecoupler pintle hook arrangement. This arrangement is known to eliminate binding. Tronair offers a Standard Telecoupler, Model Number 01-1950-5000, for use on tugs. **Reference Figure 3.**

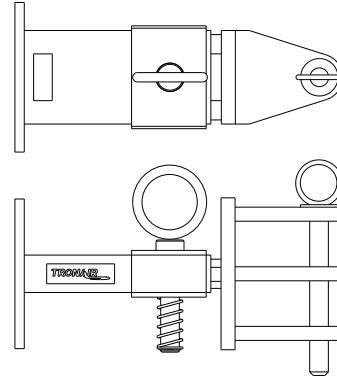

FIGURE 3
01-1950-5000 Standard Telecoupler

Damage to the towbar and/or aircraft can result by towing or pushing an aircraft with an incorrect size eyebolt or pintle pin. A correct size eyebolt will make contact with the pintle pin. A gap between the eyebolt outside diameter and the coupler face plate should be easily seen. An eyebolt which is too large will cause the eyebolt to make contact with the face plate of the coupler. When the eyebolt is too large for the coupler, a gap between the inside diameter of the eyebolt and the coupler face plate will be seen. **Reference Figure 4.**

To ensure proper towing and pushing, check to make sure the pintle pin diameter is not too long for the eyebolt's inside diameter. An approximate one-half inch ($\frac{1}{2}$ ") gap between the pin diameter and the eyebolt should be seen. If any of these conditions are not met, please contact Tronair for information to obtain a new coupler.

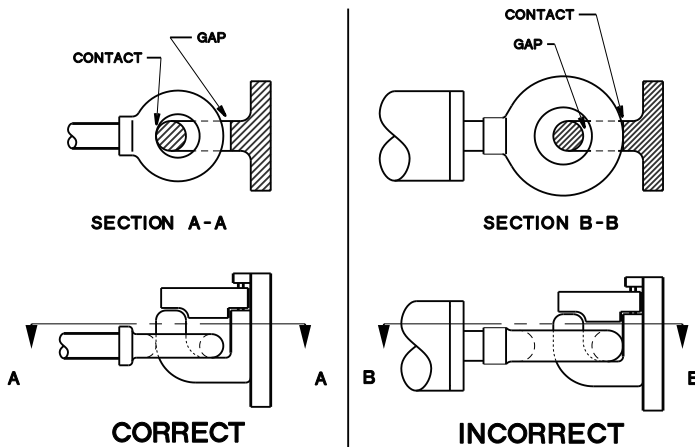

FIGURE 4

4.2.4 Towing Operation

Damage to the towbar or aircraft can result from pushing an aircraft while maintaining too sharp of an angle between the tug and the aircraft. Contact between the towbar weldment and the tug must be avoided. It is recommended that the angle between the tug and towbar not exceed 90°. **Reference Figure 5.**

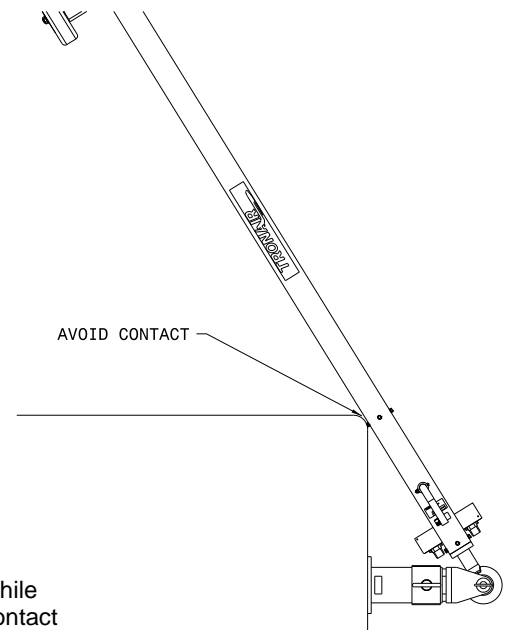

FIGURE 5

5.0 PROVISION OF SPARES**5.1 SOURCE OF SPARE PARTS**

Spare parts may be obtained from the manufacturer:

TRONAIR, Inc.	Telephone: (419) 866-6301 or 800-426-6301
1 Air Cargo Pkwy East	Fax: (419) 867-0634
Swanton, Ohio 43558 USA	E-mail: sales@tronair.com
	Website: www.tronair.com

For Spare Parts, Operations & Service Manuals or Service Needs:
Scan the QR code or visit Tronair.com/aftermarket

**5.2 RECOMMENDED SPARE PARTS LISTS**

Reference the following page(s) for Replacement Parts and Kits available.

Recommended Spares to be kept on hand:

K-1882.....Kit, Ball Lok-T Pin Replacement
K-2122.....Kit, Ball Lok-T Pin Replacement
K-1550.....Wheel (Single) Replacement
K-2051.....Kit, Sliding Pin Replacement
K-2160.....Kit, Bushing Replacement
K-2836.....Kit, Shear Bolt Replacement
K-3201.....Kit, Ball Lok-T Pin Replacement

6.0 IN SERVICE SUPPORT

Contact Tronair, Inc. for technical services and information. See Section 1.3 – Manufacturer.

7.0 GUARANTEES/LIMITATION OF LIABILITY

Tronair products are warranted to be free of manufacturing or material defects for a period of one year after shipment to the original customer. This is solely limited to the repair or replacement of defective components. This warranty does not cover the following items:

- Parts required for normal maintenance
- Parts covered by a component manufacturers warranty
- Replacement parts have a 90-day warranty from date of shipment

If you have a problem that may require service, contact Tronair immediately. Do not attempt to repair or disassemble a product without first contacting Tronair, any action may affect warranty coverage. When you contact Tronair be prepared to provide the following information:

- Product Model Number
- Product Serial Number
- Description of the problem

If warranty coverage is approved, either replacement parts will be sent or the product will have to be returned to Tronair for repairs. If the product is to be returned, a Return Material Authorization (RMA) number will be issued for reference purposes on any shipping documents. Failure to obtain a RMA in advance of returning an item will result in a service fee. A decision on the extent of warranty coverage on returned products is reserved pending inspection at Tronair. Any shipments to Tronair must be shipped freight prepaid. Freight costs on shipments to customers will be paid by Tronair on any warranty claims only. Any unauthorized modification of the Tronair products or use of the Tronair products in violation of cautions and warnings in any manual (including updates) or safety bulletins published or delivered by Tronair will immediately void any warranty, express or implied.

The obligations of Tronair expressly stated herein are in lieu of all other warranties or conditions expressed or implied. **Any unauthorized modification of the Tronair products or use of the Tronair products in violations of cautions and warnings in any manual (including updates) or safety bulletins published or delivered by Tronair will immediately void any warranty, express or implied and Tronair disclaims any and all liability for injury (WITHOUT LIMITATION and including DEATH), loss or damage arising from or relating to such misuse.**

Parts List

When ordering replacement parts/kits, please specify model, serial number and color of your unit.

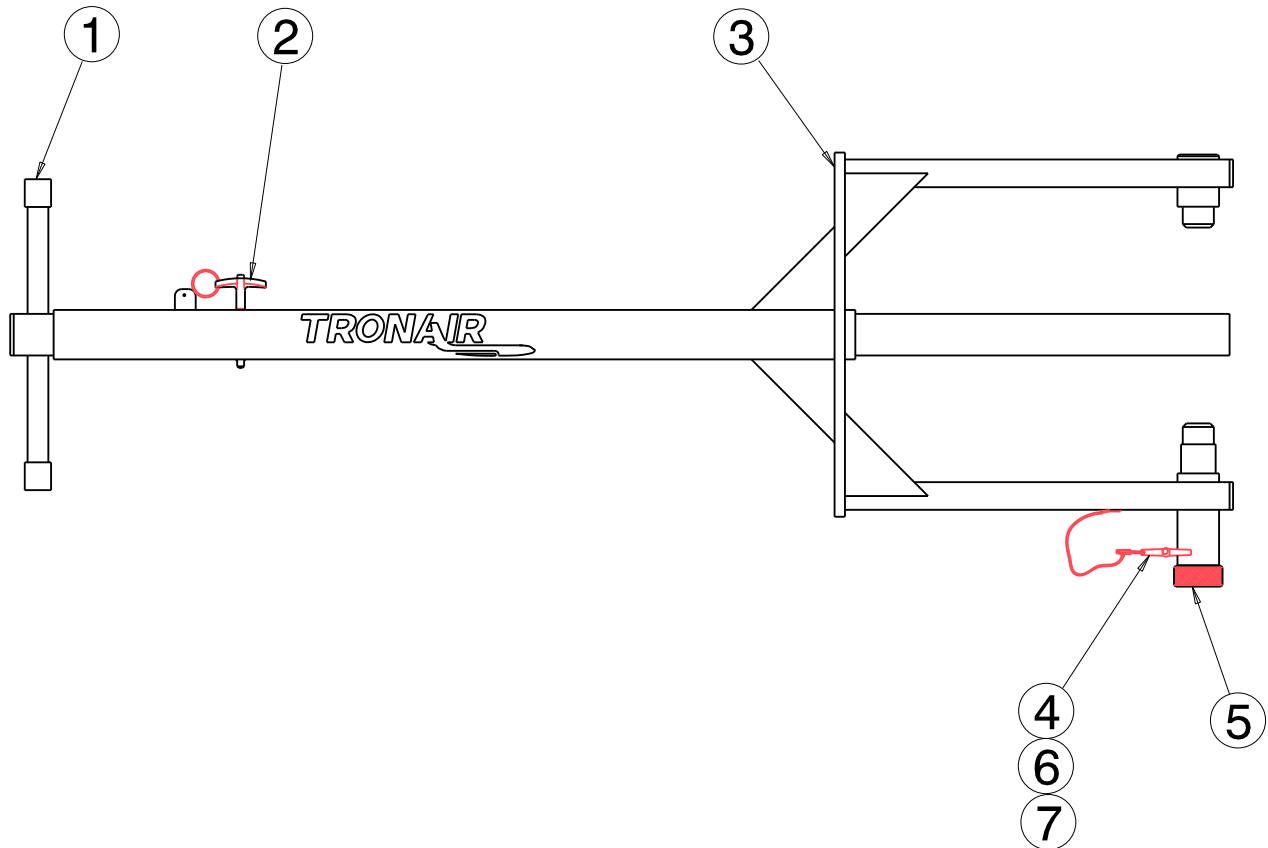

Item	Part Number	Description	Qty
1	Z-2700-01	Weldment, Inner Tube	1
5	R-1460	Pin, Sliding	1
	K-2122	Kit, Ball Lok-T Pin Replacement; consists of:	
2	G-1310-0520	Pin, 5/16" diameter x 2" Ball Lok-T	1
6	G-1351-04	Rivet, 1/8 Open-End Steel	1
7	H-1026*07.0	Assembly, Lanyard	1
	K-1882	Kit, Ball Lok Pin Replacement; consists of:	
4	G-1310-0415	Pin, ¼ " diameter x 1 ½ " Ball Lok-T	1
6	G-1351-04	Rivet, 1/8 Open-End Steel	1
7	H-1026*07.0	Assembly, Lanyard	1
	K-2218	Kit, Head Weldment Replacement; consists of:	
3	Z-2701-01	Weldment, Head	1



APPENDIX II

Declaration of Conformity



DECLARATION of CONFORMITY

The design, development and manufacture is in accordance with European Community guidelines

Lear Portable Handling Towbar
01-1239-0000

Relevant provisions complied with by the machinery:
2006/42/EC

Relevant standards complied with by the machinery:
EN ISO 12100-1

Identification of person empowered to sign on behalf of the manufacturer:

A handwritten signature in black ink that reads "Patrick Finch". The signature is written in a cursive style and is positioned above a horizontal line.

Quality Assurance Representative



Tronair, Inc.
1 Air Cargo Pkwy East
Swanton, OH 43558

Phone: (419) 866-6301 | 800-426-6301
Web: www.tronair.com
Email: sales@tronair.com