

**Model: 01-1242-0000
Towbar
Sikorsky Jayhawk/Seahawk**



11/2007 - Rev. 07

REVISION
07

DATE
11/2007

TEXT AFFECTED
Modified Parts List

Tronair towbars/heads must only be used with matching Tronair heads/towbars, and Tronair shear pins.

This product can not be modified without the written approval of Tronair, Inc. Any modifications done without written approval voids all warranties and releases Tronair, Inc., its suppliers, distributors, employees, or financial institutions from any liability from consequences that may occur. Only Tronair OEM replacement parts shall be used.

1.0 PROVISION OF SPARES

1.1 SOURCE OF SPARE PARTS

Spare parts may be obtained from the manufacturer:

TRONAIR , Inc.	Telephone: (419) 866-6301 or 800-426-6301
1 Air Cargo Pkwy East	Fax: (419) 867-0634
Swanton, Ohio 43558 USA	E-mail: sales@tronair.com
	Website: www.tronair.com

For Spare Parts, Operations & Service Manuals or Service Needs:
Scan the QR code or visit Tronair.com/aftermarket



10.2 RECOMMENDED SPARE PARTS LISTS

Reference the following page(s) for Replacement Parts and Kits available.

Recommended Spares to be kept on hand:
K-1120.....Kit, Handle (Single) Replacement
K-1271.....Kit, Bearing Set Replacement
K-2296.....Kit, Sliding Pin Replacement
K-2305.....Kit, Ball Lok-T Pin Replacement

2.0 IN-SERVICE SUPPORT

Contact Tronair for technical services and information.

3.0 GUARANTEES/LIMITATION OF LIABILITY

Tronair products are warranted to be free of manufacturing or material defects for a period of one year after shipment to the original customer. This is solely limited to the repair or replacement of defective components. This warranty does not cover the following items:

- a) Parts required for normal maintenance
- b) Parts covered by a component manufacturers warranty
- c) Replacement parts have a 90-day warranty from date of shipment

If you have a problem that may require service, contact Tronair immediately. Do not attempt to repair or disassemble a product without first contacting Tronair, any action may affect warranty coverage. When you contact Tronair be prepared to provide the following information:

- a) Product Model Number
- b) Product Serial Number
- c) Description of the problem

If warranty coverage is approved, either replacement parts will be sent or the product will have to be returned to Tronair for repairs. If the product is to be returned, a Return Material Authorization (RMA) number will be issued for reference purposes on any shipping documents. Failure to obtain a RMA in advance of returning an item will result in a service fee. A decision on the extent of warranty coverage on returned products is reserved pending inspection at Tronair. Any shipments to Tronair must be shipped freight prepaid. Freight costs on shipments to customers will be paid by Tronair on any warranty claims only. Any unauthorized modification of the Tronair products or use of the Tronair products in violation of cautions and warnings in any manual (including updates) or safety bulletins published or delivered by Tronair will immediately void any warranty, express or implied.

The obligations of Tronair expressly stated herein are in lieu of all other warranties or conditions expressed or implied. **Any unauthorized modification of the Tronair products or use of the Tronair products in violations of cautions and warnings in any manual (including updates) or safety bulletins published or delivered by Tronair will immediately void any warranty, express or implied and Tronair disclaims any and all liability for injury (WITHOUT LIMITATION and including DEATH), loss or damage arising from or relating to such misuse.**

Parts List

When ordering Replacement Parts/Kits, please specify Model, Color and Serial Number of your Unit.

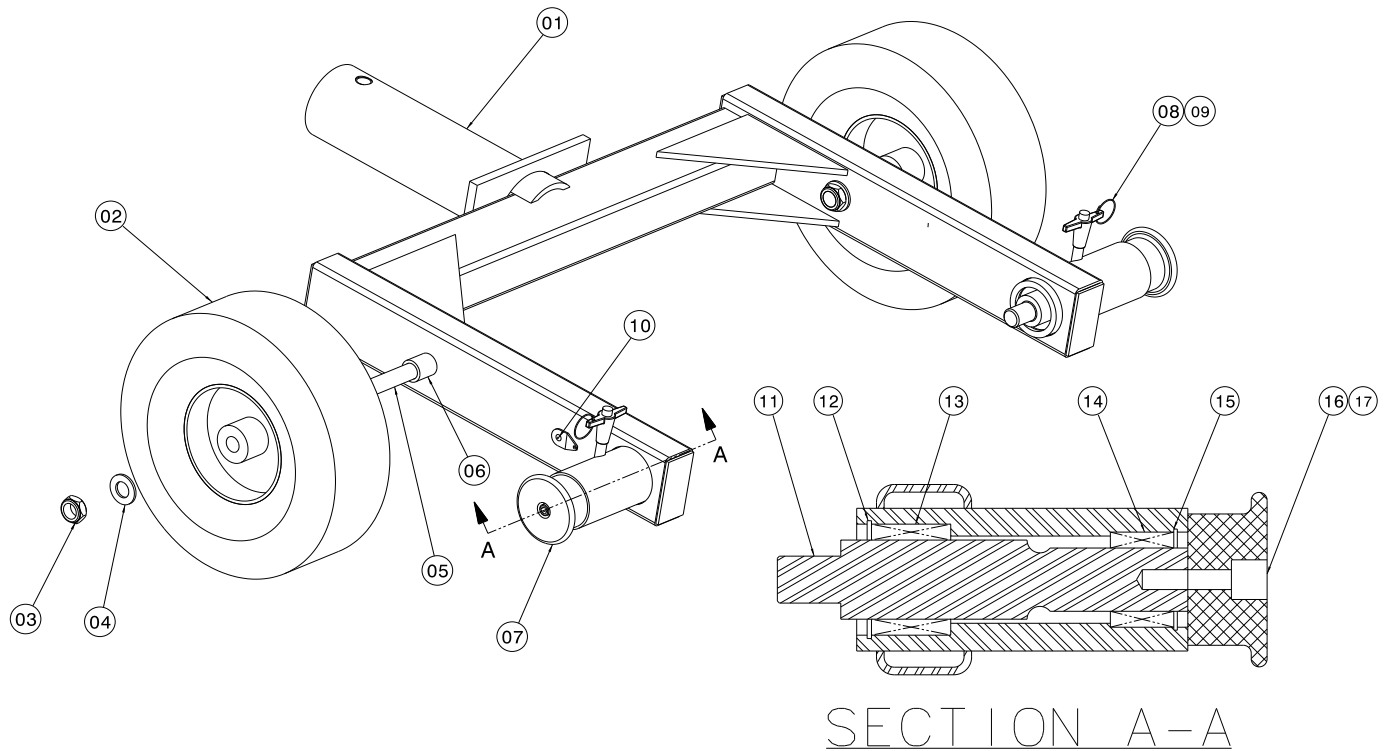

Item	Part Number	Description	Qty
1	Z-2907-01	Weldment, Head	1
2	U-1021	Wheel, Pneumatic Tire	2
3	G-1203-1105	Jamnut, 5/8-18 Elastic	4
4	G-1255-10	Washer, AN 5/8"	4
5	R-1315	Axle, Pin	2
6	TR-1347	Tube, Spacer	2
7	B-025	Handle, Locking Pin	2
8	G-1310-0630	Pin, Ball Lok-T, 3/8" x 3" long	2
9	H-1026*07.0	Assembly, Lanyard	2
10	G-1351-04	Rivet, 1/8" Open-End Steel	2
11	R-1477	Sliding Pin	2
12	G-1391-14	Internal Retaining Ring	2
13	H-1245	Roller Bearing	2
14	H-1884	Roller Bearing	2
15	G-1391-13	Internal Retaining Ring	2
16	G-1151-106212	Screw, Socket Head Cap, 5/16-18 x 1 1/4" long	2
17	G-1251-1060R	Lockwasher, 5/16 Regular	2
	K-1120	Kit, Handle (Single) Replacement; consists of:	
7	B-025	Handle, Locking Pin	1
16	G-1151-106212	Screw, Socket Head Cap, 5/16-18 x 1 1/4" long	1
17	G-1251-1060R	Lockwasher, 5/16 Regular	1
	K-1271	Kit, Bearing Set Replacement; consists of:	
12	G-1391-14	Internal Retaining Ring	1
13	H-1245	Roller Bearing	2

Parts List

When ordering Replacement Parts/Kits, please specify Model, Color and Serial Number of your Unit.

Item	Part Number	Description	Qty
	K-2305	Kit, Sliding Pin Replacement; consists of:	
7	B-025	Handle, Locking Pin	1
11	R-1477	Sliding Pin	1
16	G-1151-106212	Screw, Socket Head Cap, 5/16-18 x 1 ¼ " long	1
17	G-1251-1060R	Lockwasher, 5/16 Regular	1
	K-2296	Kit, Ball Lok-T Pin Replacement; consists of:	
8	G-1310-0630	Pin, Ball Lok-T, 3/8" x 3" long	1
9	H-1026*07.0	Assembly, Lanyard	1
10	G-1351-04	Rivet, 1/8" Open-End Steel	1
	K-2306	Kit, Bearing Assembly Replacement; consists of:	
12	G-1391-14	Internal Retaining Ring	1
13	H-1245	Roller Bearing	1
14	H-1884	Roller Bearing	1
15	G-1391-13	Internal Retaining Ring	1

Parts List

When ordering Replacement Parts/Kits, please specify Model, Color and Serial Number of your Unit.

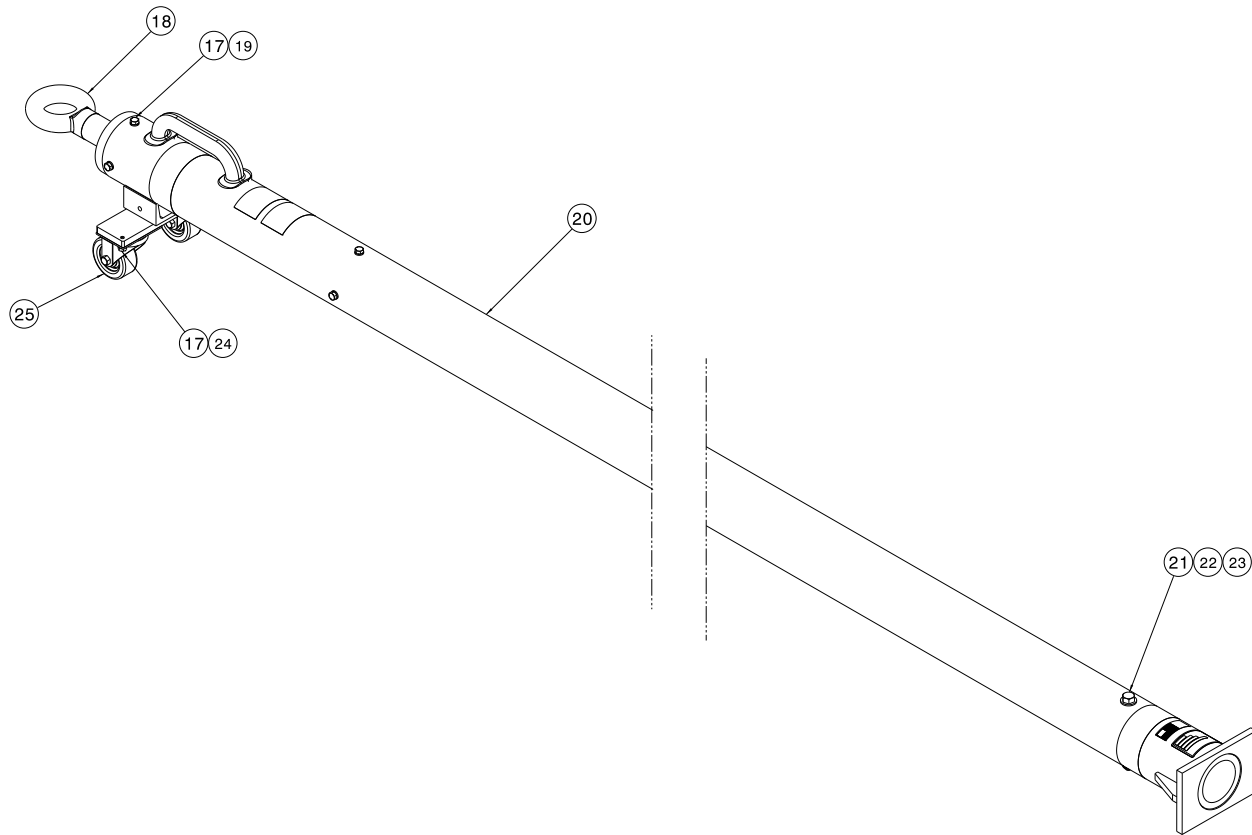

Item	Part Number	Description	Qty
17	G-1251-1060R	Lockwasher, 5/16 Regular	12
18	Z-2408	Assembly, Shock	1
19	G-1420-106006	Bolt, Hex Head, Grade 8, 5/16 – 18 x 3/4 " long	8
20	Z-2407-01	Machining, Towbar	1
21	G-1100-109554	Bolt, Hex Head, Grade 5, 1/2 - 20 x 5 1/2 " long	1
22	G-1250-1090N	Flatwasher, 1/2 Narrow	2
23	G-1202-1095	ESN, 1/2 - 20	1
24	G-1100-106005	Bolt, Hex Head, Grade 5, 5/16 – 18 x 5/8" Long	4
> 25	U-1000	Caster	2
	K-3113	Kit, Shock Assembly Replacement; consists of:	
17	G-1251-1060R	Lockwasher, 5/16 Regular	8
18	Z-2408	Assembly, Shock	1
19	G-1420-106006	Bolt, Hex Head, Grade 8, 5/16 – 18 x 3/4 " long	8
	K-1115	Kit, Shock Bolt (Set) Replacement; consists of:	
17	G-1251-1060R	Lockwasher, 5/16 Regular	12
19	G-1420-106006	Bolt, Hex Head, Grade 8, 5/16 – 18 x 3/4 " long	8

> Use Loctite 271 or equivalent during reassembly.



APPENDIX I

Towbar Usage Instructions



INS-1582

**Towbar Usage
Instructions**

11/2003 – Rev. 03

REVISION
03

DATE
11/25/03

TEXT AFFECTED
pg 1 Warning added

Your Tronair towbar is engineered and built to the highest standards of quality and workmanship. Under normal usage and with minimal maintenance this towbar will provide exceptional service.

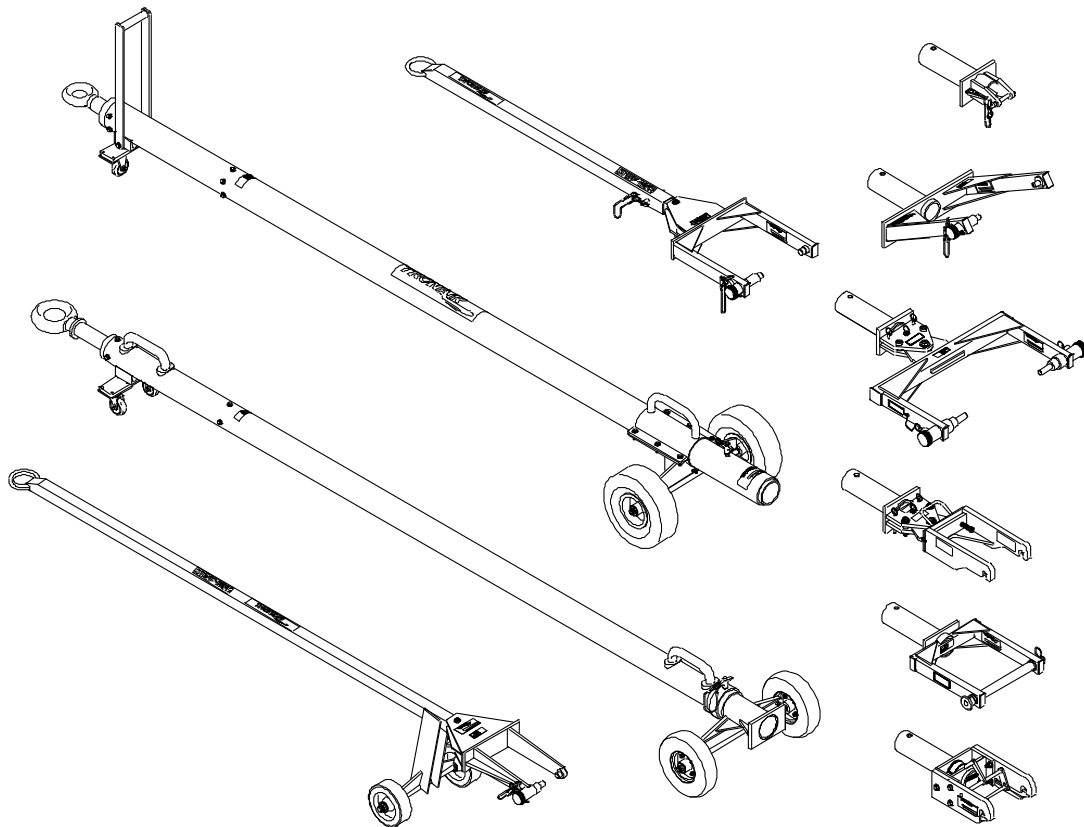

WARNING! A damaged or bent towbar should not be used, but should be repaired or replaced.

USING A DAMAGED OR BENT TOWBAR CAN RESULT IN AIRCRAFT OR EQUIPMENT DAMAGE AND POSSIBLE PERSONAL INJURY.



WARNING! Towbars With Hydraulic Lifting Mechanism:

The hydraulic lift mechanism (on those towbars so equipped) should only be used to raise the towbar to facilitate connection to the aircraft or tug.

Release any hydraulic pressure when towing aircraft or moving towbar.



WARNING! Towbars Should be Used with Category 1 Tugs:

Tronair recommends the use of a towbar with a category 1 or category 2 tug and aircraft not exceeding 75,000 lbs gross weight. Using the towbar with aircraft weighing in excess of this specific limitation may result in excessive loads and stresses being applied to the towbar and/or the aircraft. These excessive loads may cause failure of the towbar which could cause damage (INCLUDING WITHOUT LIMITATION to the aircraft) and/or personal injury OR DEATH. **TRONAIR MAKES NO REPRESENTATION, WARRANTY OR GUARANTEE AS TO SUCH MISUSE AND DISCLAIMS ANY AND ALL LIABILITY FOR INJURY, LOSS OR DAMAGE ARISING FROM OR RELATING TO SUCH MISUSE.**

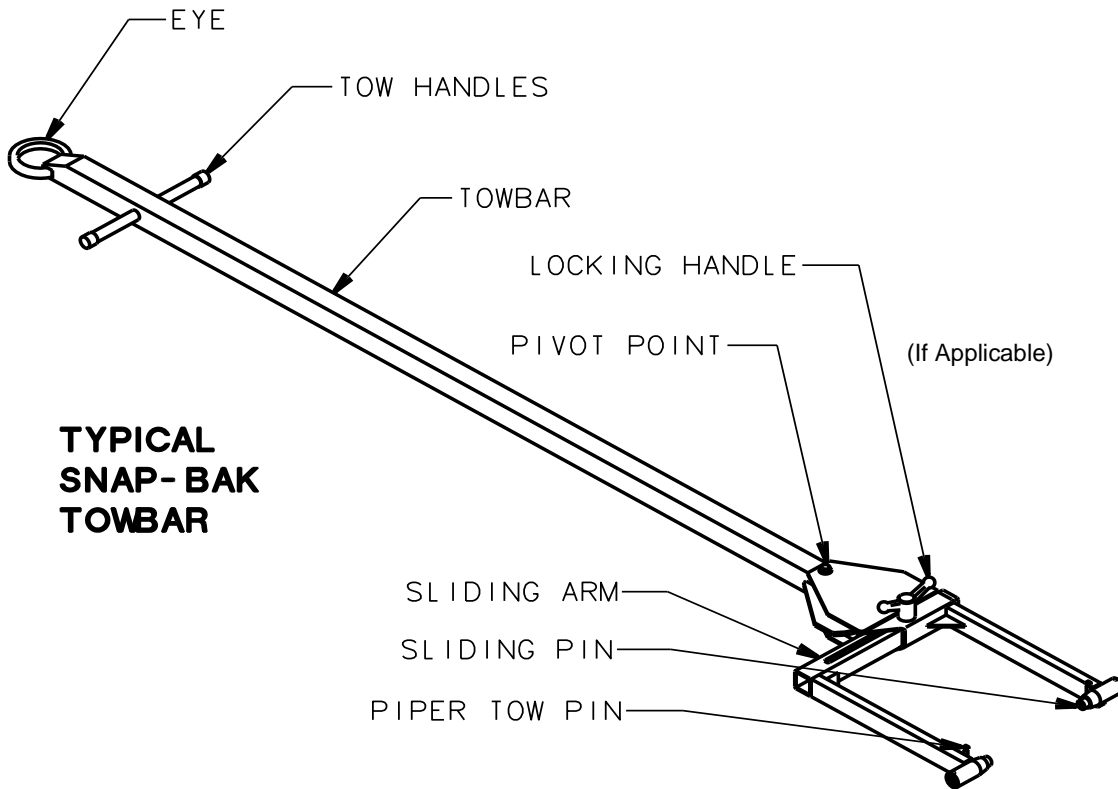

FIGURE 2

NOTE: Typical towbar. Your towbar and/or head may not have all of the features shown

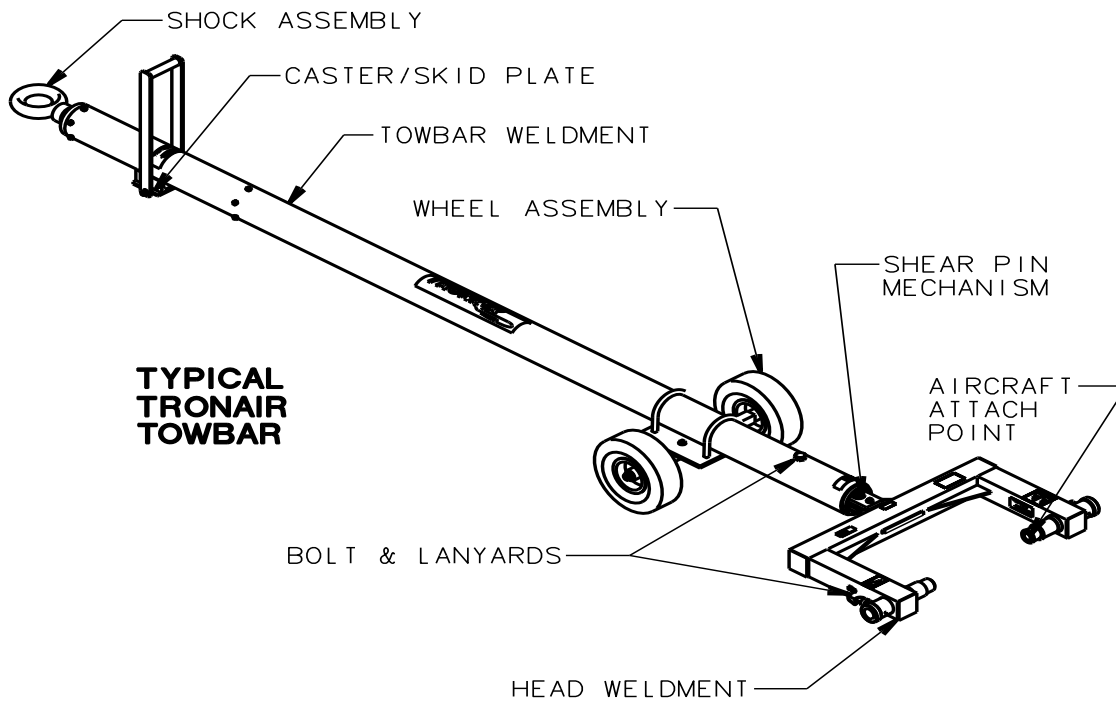

FIGURE 1

NOTE: Typical towbar. Your towbar and/or head may not have all of the features shown

BEFORE USING TOWBAR, COMPLETE THE FOLLOWING CHECKLISTS:Reference **Figures 1 & 2** on Page 2.**TOWBAR:****Area of Towbar:**

Shock Assembly:

Check:

1. Weld between eye and tube (Are there cracks?)
2. Bolts attaching shock to towbar (Loose, missing, stripped, etc.)
3. Eyebolt (Is it bent, worn down, or deformed?)

Towbar Weldment:

1. Tube (Is it bent, dented, bowed, and/or have cracks?)
2. Weld at head end (Are there any cracks in the welds?)
3. Head hole (Is it elongated? Is the ball lok pin attached to the towbar?)

Caster/Skid Plate:

1. Casters (Are they missing or bent?)
2. Handles (Are they broken, bent, or missing?)
3. Bolts (Are they missing or loose?)

Wheel Assembly:

1. Wheels (Are they flat? Is the rim bent?)
2. Axle (Is it bent?)

HEAD:**Area of Head:**

Bolts & Lanyards:

Check:

1. Are they loose, missing, or stripped? Are they attached to the head?

Weldment:

1. Welds holding side rails to head rail (Are there any cracks?)
2. Shear Plates (Are there cracks in welds? Are the plates bent?)

Shear Pin Mechanism:

1. Shear Pin (Is it bent or deformed? Are there spares?)
2. Bushings (Are they cracked, chipped, secure?)
3. Pivot Bolt (Are the nuts tight? Are there washers present?)

Area of Head:

Aircraft Attach Point:

Check:

1. Sliding Pin(s) (Are they bent, cracked? Do they slide freely?)
2. Locking Pin (Are they loose? Do they hold the sliding pins securely?)
3. Wear sleeves (Are the welds cracked?)
4. Roll Pins(s) (Are they rusted? Are they missing? Are they loose?)
5. Ball Lok Pin (Is it attached to head? Is it rusted? Is it bent?)
6. Axle Adapter (Is it bent? Is the slot deformed? Are bolts tight?)

SNAP-BAK AND UNIVERSAL TOWBARS:**Area of Towbar:**

Towbar:

Check:

1. Spring (Has it taken a set? Loose in the assembly?)
2. Eyebolt (Is it bent, worn down, or deformed?)
3. Tube (Is it bent, dented, bowed, or cracked? Is it rusted badly?)
4. Welds (Are there any cracks in the welds?)
5. Head Hole (Is it elongated? Is the bolt attached correctly?)

Function:

1. Does it snap back?

Head:

1. Pivot Bolt (Is it present along with washers? Is the nut tight? Is it rusted?)
2. Roll Pin(s) (Are they rusted? Are they missing? Are they loose?)
3. Weldment (Is it deformed, bent, or rusted beyond reasonable use?)
4. Lanyard (Is it attached to weldment?)
5. Sliding Pin(s) (Are they bent, cracked or rusted? Does it slide?)

USAGE PROCEDURE

Aircraft Attachment:

It is recommended that your towbar be attached to the aircraft first, and then connected to the tug to avoid possible aircraft damage.

Ensure sliding pins are locked in place before towing aircraft.

Tug Attachment:

Damage to the towbar or aircraft can result from an excessive towbar angle during towing operations (See **Figure 3**). If aircraft with both high and low tow points are encountered, consider using two pintle hooks, as shown in **Figures 4 & 5**, so that the towbar is as level as possible during towing. Also pintle hook height should prevent contact of towbar wheels with the ground, during towing. (See **Figure 5**).

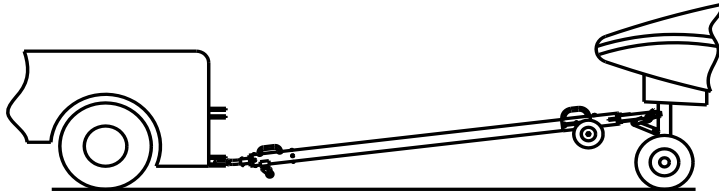

FIGURE 3 - INCORRECT

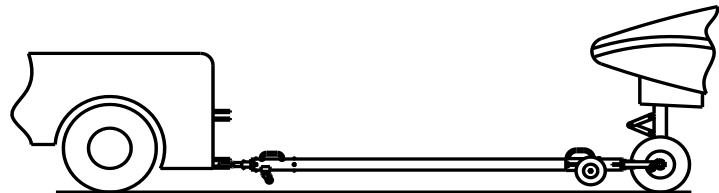

FIGURE 4 - CORRECT

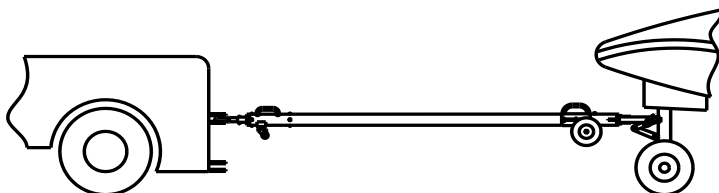

FIGURE 5 - CORRECT

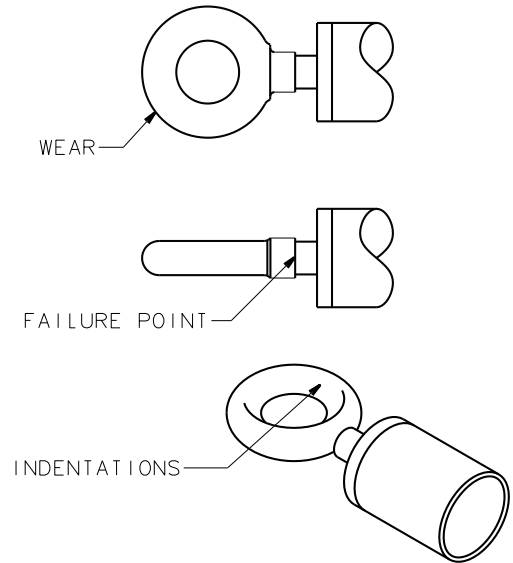

FIGURE 6

Type Of Coupler:

Damage to the towbar or aircraft can result while towing with the following type of couplers:

- Lift Head
- Standard Duty Latch
- Vertical Side Swing Latch
- Swivel Hook

These types of couplers are known to cause binding and failure in the eyebolt. Indicators of eyebolt binding are wear on the outside diameter of the eye and indentations on the inside diameter. The failure will begin at the head of the eye. See **Figure 6**.

USAGE PROCEDURE (continued)

Type Of Coupler:

Damage to the towbar or aircraft can result while towing with the following type of couplers:

- Lift Head
- Standard Duty Latch
- Vertical Side Swing Latch
- Swivel Hook

These types of couplers are known to cause binding and failure in the eyebolt. Indicators of eyebolt binding are wear on the outside diameter of the eye and indentations on the inside diameter. The failure will begin at the head of the eye.

See **Figure 6**.

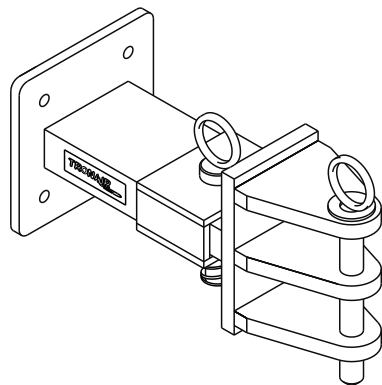

FIGURE 7

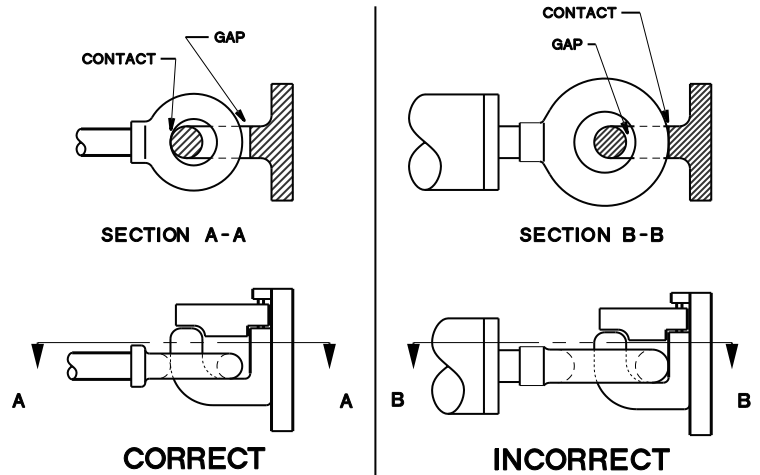

FIGURE 8

Figure 7 illustrates a pintle hook arrangement that is known to eliminate eyebolt binding. Tronair recommends using this type of hook on your tug.

Eyebolt and Pintle Pin Size:

Damage to the towbar or aircraft can result by towing or pushing an aircraft with an incorrect size eyebolt or pintle pin. A correct size eyebolt will make contact with the pintle pin. A gap between the eyebolt outside diameter and the coupler face plate should be easily seen. An eyebolt which is too large will cause the eyebolt to make contact with the face plate of the coupler. When the eyebolt is too large for the coupler, a gap between the inside diameter of the eyebolt and the coupler face plate will be seen.

See **Figure 8**.

To ensure proper towing and pushing, check to make sure that the pintle pin diameter is not too large for the eyebolt's inside diameter. Approximately a one-half inch (1/2") gap between the pin diameter and the eyebolt should be seen. If any of these conditions are not met, please contact Tronair for information to obtain a new coupler.

Towing Angle:

Damage to the towbar or aircraft can result from pushing an aircraft while maintaining too sharp of an angle between the tug and the towbar. Contact between the towbar weldment and tug must be avoided. It is recommended that the angle between the tug and towbar not exceed 90°.

See **Figure 9**.

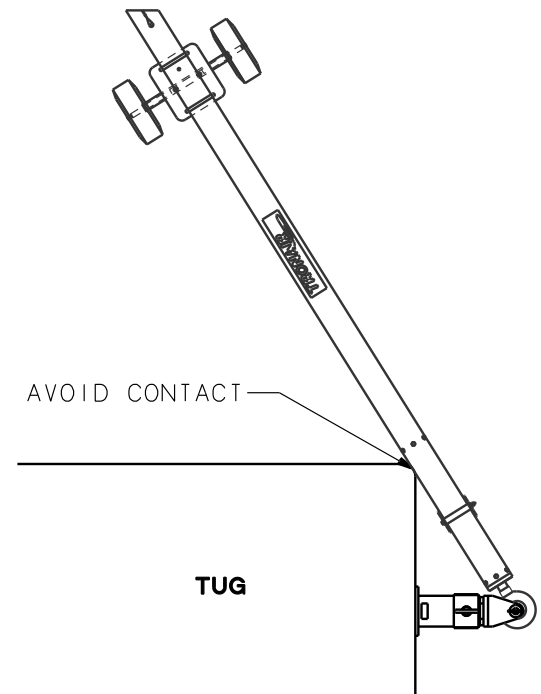

FIGURE 9



APPENDIX II

Declaration of Conformity



DECLARATION of CONFORMITY

The design, development and manufacture is in accordance with European Community guidelines

Towbar
01-1242-0000

Relevant provisions complied with by the machinery:
2006/42/EC

Relevant standards complied with by the machinery:
EN ISO 12100-1

Identification of person empowered to sign on behalf of the Manufacturer:

A handwritten signature in cursive script that reads "Patrick Finch". The signature is written in black ink and is positioned above a horizontal line.

Quality Assurance Representative