

**Model: 01-1261-0011
Portable Towbar
Gulfstream GII, GIII, GIV, GV**



03/2007 – Rev. 02

**For Spare Parts, Operations & Service Manuals or Service Needs
Scan the QR code or visit Tronair.com/aftermarket**



REVISION	DATE	TEXT AFFECTED
OR	10/2004	Original Release
01	03/2006	Modified Parts List
02	03/2007	Added CE marking, Modified 1.1, 3.2.2, and Parts Lists

TABLE OF CONTENTS

	<u>PAGE</u>
1.0 PRODUCT INFORMATION	1
1.1 DESCRIPTION	1
1.2 MODEL & SERIAL NUMBER	1
1.3 MANUFACTURER.....	1
1.4 SPECIFICATIONS.....	1
2.0 SAFETY INFORMATION	1
2.1 GENERAL.....	1
3.0 TRAINING	2
3.1 TRAINING REQUIREMENTS.....	2
3.2 TRAINING PROGRAM	2
3.3 OPERATOR TRAINING.....	2
4.0 OPERATION	2
4.1 TOWBAR CHECKLIST	2
4.2 USAGE PROCEDURE	2
4.2.1 Aircraft Attachment.....	2
4.2.2 Tug Attachment.....	3
4.2.3 Couplers.....	4
4.2.4 Towing Operation.....	4
5.0 PROVISION OF SPARES	5
5.1 SOURCE OF SPARE PARTS	5
5.2 RECOMMENDED SPARE PARTS LISTS	5
6.0 IN-SERVICE SUPPORT	5
7.0 GUARANTEES/LIMITATION OF LIABILITY	5

Tronair towbars/heads must only be used with matching Tronair heads/towbars, and Tronair shear pins.

This product cannot be modified without the written approval of Tronair, Inc. Any modifications done without written approval voids all warranties and releases Tronair, Inc., its suppliers, distributors, employees, or financial institutions from any liability from consequences that may occur. Only Tronair OEM replacement parts shall be used.

1.0 PRODUCT INFORMATION

1.1 DESCRIPTION

The Tronair Model 01-1261-0011 Portable Towbar is designed for towing Gulfstream GII, GIII, GIV, and GV Aircraft manufactured by Gulfstream Aerospace Corporation.

The portable towbar separates into three sections for compact storage, It interfaces to the aircraft by machined pins. It provides overload protection to the landing gear by use of a shear pin and incorporates shock protection after the shear pin breaks.

1.2 MODEL & SERIAL NUMBER

Reference nameplate on unit

1.3 MANUFACTURER

TRONAIR, Inc.
1 Air Cargo Pkwy East
Swanton, Ohio 43558 USA

Telephone: (419) 866-6301 or 800-426-6301
Fax: (419) 867-0634
E-mail: sales@tronair.com
Website: www.tronair.com

1.4 SPECIFICATIONS

Aircraft Application Gulfstream GII, GIII, GIV, and GV manufactured by Gulfstream Aerospace Corporation
Maximum Aircraft Gross Weight.... 90,900 lbs (41.2 Metric tons)
Length 110 7/16 in (280.5 cm) From eyebolt centerline to aircraft attachment centerline
Width 29 5/8 in (75.2 cm)
Height..... 5 3/8 in (13.7 cm)
Weight..... 77 lbs (35 kg)
Finish..... Blue Powder Coat

2.0 SAFETY INFORMATION

2.1 GENERAL

The Tronair Model 01-1261-0011 Portable Towbar is to be used for moving the Gulfstream GII, GIII, GIV, and GV aircraft only.

To ensure safe operation, please read the following statements and understand their meaning. This manual contains safety precautions which are explained as follows. Please read carefully.



WARNING! Warning is used to indicate the presence of a hazard that can cause **severe personal injury, death, and/or substantial property damage** if the Warning Notice is ignored.

CAUTION! Caution is used to indicate the presence of a hazard which will or can **cause minor personal injury or property damage** if the Caution Notice is ignored.



WARNING!

A damaged or bent towbar should not be used. Towbar should be repaired or replaced.



WARNING!

Tronair recommends the use of a towbar with a category 1 or category 2 tug and aircraft not exceeding 75,000 lbs gross weight. Using the towbar with aircraft weighing in excess of this specific limitation may result in excessive loads and stresses being applied to the towbar and/or the aircraft. These excessive loads may cause failure of the towbar which could cause damage (INCLUDING WITHOUT LIMITATION to the aircraft) and/or personal injury OR DEATH. TRONAIR MAKES NO REPRESENTATION, WARRANTY OR GUARANTEE AS TO SUCH MISUSE AND DISCLAIMS ANY AND ALL LIABILITY FOR INJURY, LOSS OR DAMAGE ARISING FROM OR RELATING TO SUCH MISUSE.

3.0 TRAINING**3.1 TRAINING REQUIREMENTS**

The employer of the operator is responsible for providing a training program sufficient for the safe operation of the towbar.

3.2 TRAINING PROGRAM

The employer provided operator training program should cover safety procedures concerning use of the towbar in and around the aircraft at the servicing location.

3.3 OPERATOR TRAINING

The operator training should provide the required training for safe operation of the towbar.

NOTE: Maintenance and Trouble Shooting are to be performed by the skilled and trained technician.

4.0 OPERATION**4.1 TOWBAR CHECKLIST**

- Check eyebolt for bending, excessive wear and/or deformity. If located, remove towbar from service and contact Tronair for repair/replacement.
- Inspect shear bolt. If shear bolt is bent or broken remove towbar from service and contact Tronair for replacement.

**WARNING!**

Towing an aircraft using a towbar with a broken or missing shear bolt may cause damage to the aircraft

- Check shock/shear assembly mounting bolts. Ensure fasteners are tight and not missing. Tighten to 25 ft-lbs or replace as required.
- Inspect towbar tube and towbar extension tube for cracks, gouges greater than 1/16 inch, and bends or deformities. If located, remove towbar from service and contact Tronair for repair/replacement.
- Check towbar section connecting ball lok-T pins. Ensure they are not missing and are connected to the towbar via their lanyards. Replace as required.
- Check head weldment mounting bolts. Ensure they are tight and not missing. Tighten or replace as required.
- Inspect all welds for cracks. If located, remove towbar from service and contact Tronair for repair/replacement.
- Inspect all members of head weldment for bending or damage. If located, remove towbar from service and contact Tronair for repair/replacement.
- Inspect sliding pins for bending, cracks, and excessive wear. If located, remove towbar from service and contact Tronair for repair/replacement.
- Check sliding pin retaining ball lok-T pins. Ensure they are not missing and are connected to the head weldments via their lanyards. Replace as required.
- Check sliding pin roll pins. Ensure they are tight and not missing. Tighten or replace as required.

4.2 USAGE PROCEDURE**4.2.1 Aircraft Attachment****CAUTION!**

It is recommended that your towbar be attached to the aircraft first, and then connected to the tug to avoid possible aircraft damage.

4.2.2 Tug Attachment

- Use a pintle height so that the towbar is as level as possible during towing. Also, the pintle hook height should prevent contact of the towbar with the ground during towing.



CAUTION!

Damage to the towbar or aircraft can result from an excessive towbar angle during towing operations. Reference Figure 1.



WARNING!

Towbars Should be Used with Category 1 Tugs:

Towbars should be used with category 1 tugs only in accordance with AHM 995 "Functional specifications for an aircraft tractor." Using a category 2 or higher tug may result in excessive loads and stresses being applied to the towbar and/or the aircraft. These excessive loads may cause failure of the towbar which could cause damage to the aircraft or personal injury

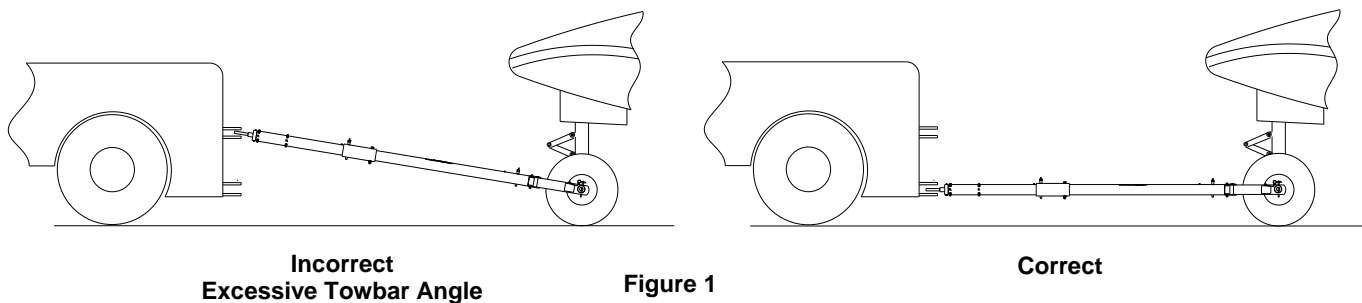

4.2.3 Couplers



CAUTION!

Damage to the towbar or aircraft can result while towing with the following types of couplers:

- Lift Head
- Standard Duty Latch
- Vertical Side Swing Latch
- Swivel Hook

The couplers listed above are known to cause binding and failure in the eyebolt. Indicators of binding are wear on outside diameter of the eyebolt and indentation on the inside diameter of the eyebolt. **Reference Figure 2.**

Tronair recommends a telecoupler pintle hook arrangement. This arrangement is known to eliminate binding. Tronair offers a Standard Telecoupler, Model Number 01-1950-5000, for use on tugs. **Reference Figure 3.**

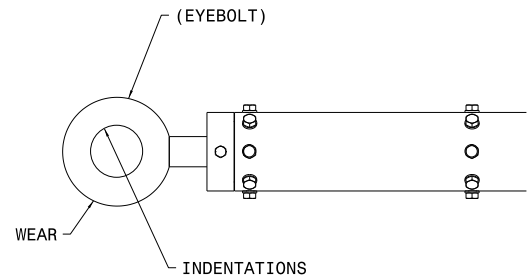

Figure 2

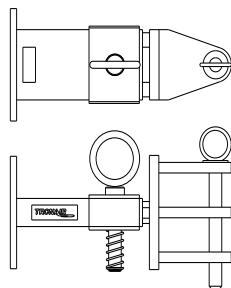

FIGURE 3

01-1950-5000 Standard Telecoupler

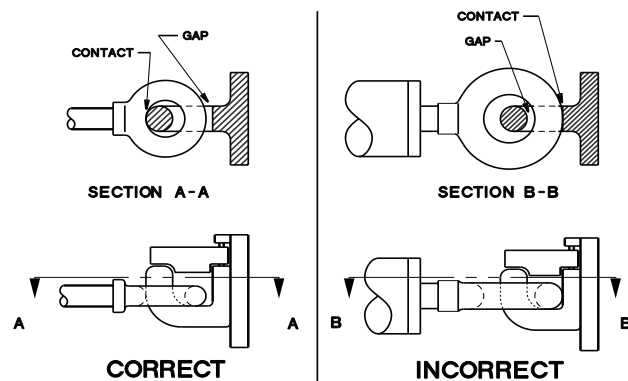

FIGURE 4

Damage to the towbar and/or aircraft can result by towing or pushing an aircraft with an incorrect size eyebolt or pintle pin. A correct size eyebolt will make contact with the pintle pin. A gap between the eyebolt outside diameter and the coupler face plate should be easily seen. An eyebolt which is too large will cause the eyebolt to make contact with the face plate of the coupler. When the eyebolt is too large for the coupler, a gap between the inside diameter of the eyebolt and the coupler face plate will be seen.

Reference Figure 4.

To ensure proper towing and pushing, check to make sure the pintle pin diameter is not too long for the eyebolt's inside diameter. An approximate one-half inch ($\frac{1}{2}$ ") gap between the pin diameter and the eyebolt should be seen. If any of these conditions are not met, please contact Tronair for information to obtain a new coupler.

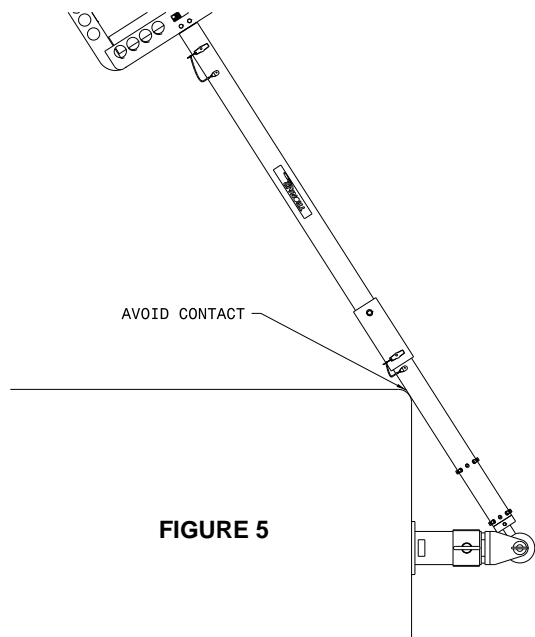

FIGURE 5

4.2.4 Towing Operation

Damage to the towbar or aircraft can result from pushing an aircraft while maintaining too sharp of an angle between the tug and the aircraft. Contact between the towbar weldment and the tug must be avoided. It is recommended that the angle between the tug and towbar not exceed 90°.

Reference Figure 5

5.0 PROVISION OF SPARES**5.1 SOURCE OF SPARE PARTS**

Spare parts may be obtained from the manufacturer:

TRONAIR, Inc.	Telephone: (419) 866-6301 or 800-426-6301
1 Air Cargo Pkwy East	Fax: (419) 867-0634
Swanton, Ohio 43558 USA	E-mail: sales@tronair.com
	Website: www.tronair.com

For Spare Parts, Operations & Service Manuals or Service Needs:
Scan the QR code or visit Tronair.com/aftermarket

**5.2 RECOMMENDED SPARE PARTS LISTS**

Reference the following page(s) for Replacement Parts and Kits available.

Recommended Spares to be kept on hand:

K-1605.....Kit, Ball Lok-T Pin Replacement
K-2564.....Kit, Ball Lok Pin Replacement
K-3983.....Kit, Sliding Pin Replacement
K-3986.....Kit, Ball Lok-T Pin Replacement

6.0 IN-SERVICE SUPPORT

Contact Tronair, Inc. for technical services and information. See Section 1.3 – Manufacturer.

7.0 GUARANTEES/LIMITATION OF LIABILITY

Tronair products are warranted to be free of manufacturing or material defects for a period of one year after shipment to the original customer. This is solely limited to the repair or replacement of defective components. This warranty does not cover the following items:

- Parts required for normal maintenance
- Parts covered by a component manufacturers warranty
- Replacement parts have a 90-day warranty from date of shipment

If you have a problem that may require service, contact Tronair immediately. Do not attempt to repair or disassemble a product without first contacting Tronair, any action may affect warranty coverage. When you contact Tronair be prepared to provide the following information:

- Product Model Number
- Product Serial Number
- Description of the problem

If warranty coverage is approved, either replacement parts will be sent or the product will have to be returned to Tronair for repairs. If the product is to be returned, a Return Material Authorization (RMA) number will be issued for reference purposes on any shipping documents. Failure to obtain a RMA in advance of returning an item will result in a service fee. A decision on the extent of warranty coverage on returned products is reserved pending inspection at Tronair. Any shipments to Tronair must be shipped freight prepaid. Freight costs on shipments to customers will be paid by Tronair on any warranty claims only. Any unauthorized modification of the Tronair products or use of the Tronair products in violation of cautions and warnings in any manual (including updates) or safety bulletins published or delivered by Tronair will immediately void any warranty, express or implied.

The obligations of Tronair expressly stated herein are in lieu of all other warranties or conditions expressed or implied. **Any unauthorized modification of the Tronair products or use of the Tronair products in violations of cautions and warnings in any manual (including updates) or safety bulletins published or delivered by Tronair will immediately void any warranty, express or implied and Tronair disclaims any and all liability for injury (WITHOUT LIMITATION and including DEATH), loss or damage arising from or relating to such misuse.**

This page left blank intentionally.

Parts List

When ordering replacement parts/kits, please specify model, serial number and color of your unit.

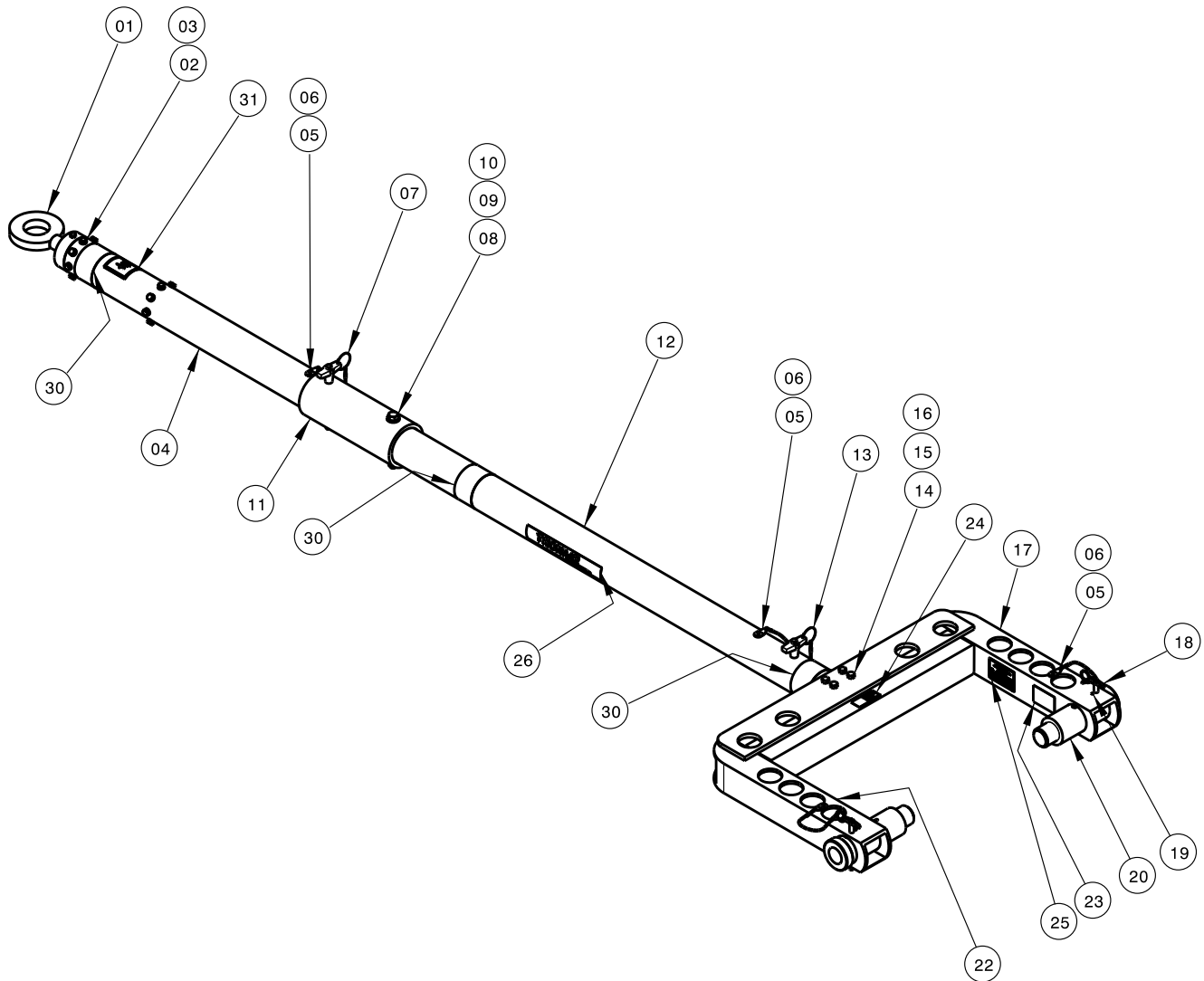

Item	Part Number	Description	Qty
	K-3981	Kit, Assembly, Shock, Shear; consists of:	1
1	Z-6040	Assembly, Shock/Shear	1
2	G-1420-106010	Bolt, Hex Head, Grade 8, 5/16 – 18 x1" long	16
3	G-1251-1060R	Lockwasher, 5/16 Regular	16
	K-3982	Kit, Tube Towbar; consists of:	1
4	TR-1891-01	Tube, Towbar 8-bolt	1
5	G-1351-04	Rivet, Pop	4
6	H-1026*07.0	Assembly, Lanyard	4
7	G-1310-0843	Pin, Ball Lok-T, ½" diameter x 4.3" Grip	1
30	H-2806*011.00	Reflector, Yellow	1
31	J-2131	Label, Maximum Towing Speed	1
	K-1605	Kit, Replacement Ball Lok Pin; consists of:	1
5	G-1351-04	Rivet, Pop	4
6	H-1026*07.0	Assembly, Lanyard	4
7	G-1310-0843	Pin, Ball Lok-T, ½" diameter x 4.3" Grip	1

Parts List

When ordering replacement parts/kits, please specify model, serial number and color of your unit.

Item	Part Number	Description	Qty
	K-2564	Kit, Ball Lok Pin; consists of:	1
5	G-1351-04	Rivet, Pop	4
6	H-1026*07.0	Assembly, Lanyard	4
13	G-1310-0835	Pin, Ball Lok-T, ½" diameter x 3.5" Grip	1
	K-3980	Kit, Head Assembly; consists of:	1
5	G-1351-04	Rivet, Pop	4
6	H-1026*07.0	Assembly, Lanyard	4
14	G-1420-107544	Bolt, Hex Head, Grade 8, 3/8 – 24 x 4 ½ " long	4
15	G-1250-1070N	Flatwasher, 3/8 Narrow	4
16	G-1202-1075	Stopnut, 3/8 - 24 Elastic	4
17	Z-6041-01	Weldment, Head	1
18	G-1310-0535	Pin, Ball Lok-T, 5/16" diameter x 3.5" Grip	2
19	G-1300-19040	Pin, Roll	2
20	R-2173	Pin, Sliding	1
21	R-2174	Pin, Sliding	1
22	V-1700	Label, Gulfstream	1
23	V-1701	Label, Gulfstream	1
24	V-1001	Label, Made in USA	1
25	V-2123	Label, Serial Number CE	1
N/S	J-3664	Adapter, Tube	1
	K-3983	Kit, Pin Sliding; consists of:	1
19	G-1300-19040	Pin, Roll	2
20	R-2173	Pin, Sliding	1
21	R-2174	Pin, Sliding	1
	K-3984	Kit, Sleeve Connector; consists of:	1
8	G-1100-109550	Bolt, Hex Head, Grade 5, ½ – 20 x 5" long	1
9	G-1250-1090N	Flatwasher, ½ Narrow	2
10	G-1202-1095	Stopnut, ½ - 20 Elastic	1
11	TR-1893-01	Sleeve, Connector	1
	K-3985	Kit, Tube Towbar Extension; consists of:	1
5	G-1351-04	Rivet, Pop	4
6	H-1026*07.0	Assembly, Lanyard	4
12	TR-1892-01	Tube, Towbar Extension	1
13	G-1310-0835	Pin, Ball Lok-T, ½" diameter x 3.5" Grip	1
26	V-1002-02	Label, Tronair	2
30	H-2806*011.00	Reflector, Yellow	2
	K-3986	Kit, Ball Lok-T; consists of:	1
5	G-1351-04	Rivet, Pop	4
6	H-1026*07.0	Assembly, Lanyard	4
18	G-1310-0535	Pin, Ball Lok-T, 5/16" diameter x 3.5" Grip	2



APPENDIX I

Declaration of Conformity



DECLARATION of CONFORMITY

The design, development and manufacture is in accordance with European Community guidelines

Portable Towbar
01-1261-0011

Relevant provisions complied with by the machinery:
2006/40/EC

Relevant standards complied with by the machinery:
EN ISO 12100-1

Identification of person empowered to sign on behalf of the manufacturer:

A handwritten signature in black ink that reads "Patrick Finch". The signature is written in a cursive style and is positioned above a horizontal line.

Quality Assurance Representative

