

**Model: 01-1264-0000**  
**Steel Towbar**  
**Learjet and Citation I & II**



11/2007 – Rev. 04

**For Spare Parts, Operations & Service Manuals or Service Needs**  
**Scan the QR code or visit [Tronair.com/aftermarket](http://Tronair.com/aftermarket)**



REVISION	DATE	TEXT AFFECTED
02	01/2004	2.0 Added Warning
03	04/2007	Modified Parts List Items 11-19
04	11/2007	Modified Parts List, Added CE marking and Declaration of Conformity

**TABLE OF CONTENTS**

	<b><u>PAGE</u></b>
<b>1.0 PRODUCT INFORMATION .....</b>	<b>1</b>
1.1 DESCRIPTION.....	1
1.2 MODEL & SERIAL NUMBER.....	1
1.3 MANUFACTURER .....	1
1.4 SPECIFICATIONS .....	1
<b>2.0 SAFETY INFORMATION.....</b>	<b>1</b>
2.1 GENERAL.....	1
<b>3.0 TRAINING.....</b>	<b>2</b>
3.1 TRAINING REQUIREMENTS .....	2
3.2 TRAINING PROGRAM .....	2
3.3 OPERATOR TRAINING.....	2
<b>4.0 OPERATION.....</b>	<b>2</b>
4.1 PRELIMINARY CHECKLIST.....	2
4.1.1 Towbar.....	2
4.1.2 Towing Head.....	2
4.2 USAGE PROCEDURE.....	2
4.2.1 Aircraft Attachment.....	2
4.2.2 Tug Attachment.....	2
4.2.3 Couplers.....	3
4.2.4 Set Sliding Pin.....	4
4.2.5 Towing Operation.....	4
<b>5.0 PROVISION OF SPARES.....</b>	<b>5</b>
5.1 SOURCE OF SPARE PARTS.....	5
5.2 RECOMMENDED SPARE PARTS LISTS .....	5
<b>6.0 IN-SERVICE SUPPORT.....</b>	<b>5</b>
<b>7.0 GAURANTEES/LIMITATION OF LIABILITY .....</b>	<b>5</b>
<b>8.0 APPENDICES .....</b>	<b>5</b>

Tronair towbars/heads must only be used with matching Tronair heads/towbars, and Tronair shear pins.

This product cannot be modified without the written approval of Tronair, Inc. Any modifications done without written approval voids all warranties and releases Tronair, Inc., its suppliers, distributors, employees, or financial institutions from any liability from consequences that may occur. Only Tronair OEM replacement parts shall be used.

## 1.0 PRODUCT INFORMATION

### 1.1 DESCRIPTION

The Tronair Model 01-1264-0000 Steel Towbar is designed for towing Learjet 23, 24, 35, 55, C-21A, 45, 60 Aircraft manufactured by Bombardier Aerospace, as well as Citation I, II, SII, V, Bravo, and Ultra Aircraft manufactured by Cessna Aircraft Company

The steel towbar has an aircraft attachment by machined pins on the towing head to the nose landing gear tow point. There is a handle and an eyebolt at the end of the towbar for towing.

### 1.2 MODEL & SERIAL NUMBER

Reference nameplate on unit

### 1.3 MANUFACTURER

**TRONAIR**, Inc.  
1 Air Cargo Pkwy East  
Swanton, Ohio 43558 USA

Telephone: (419) 866-6301 or 800-426-6301  
Fax: (419) 867-0634  
E-mail: sales@tronair.com  
Website: www.tronair.com

### 1.4 SPECIFICATIONS

Aircraft Applications..... Learjet 23, 24, 35, 55, C-214, 45, 60 Aircraft manufactured by Bombardier Aerospace  
..... Citation I, II, SII, V, Bravo, and Ultra Aircraft manufactured by Cessna Aircraft Co.  
Max Aircraft Gross Weight ... 22,000 lbs (9.98 Metric tons)  
Length ..... 134 15/16 in (342.74 cm) From eyebolt centerline to aircraft attachment centerline  
Width ..... 22 7/8 in (58.1 cm)  
Height..... 13 3/8 in (34 cm)  
Weight ..... 85 lbs (38.6 kg)  
Finish..... Blue Powder Coat

## 2.0 SAFETY INFORMATION

### 2.1 GENERAL

The Tronair Model 01-1264-0000 Steel Towbar is to be used for moving the Learjet 23, 24, 35, 55, C-21A, 45, 60, as well as Citation I, II, SII, V, Bravo, and Ultra aircraft only.

To ensure safe operation, please read the following statements and understand their meaning. This manual contains safety precautions which are explained as follows. Please read carefully.



**WARNING!** Warning is used to indicate the presence of a hazard that can cause *severe personal injury, death, and/or substantial property damage* if the **Warning Notice** is ignored.

**CAUTION!** Caution is used to indicate the presence of a hazard which will or can cause *minor personal injury or property damage* if the **Caution Notice** is ignored.



#### **WARNING!**

A damaged or bent towbar should not be used. Towbar should be repaired or replaced.



#### **WARNING!**

Towbars should be used with category 1 tugs only in accordance with AHM 995 "Functiona1 specifications for an aircraft tractor." Using a category 2 or higher tug may result in excessive loads and stresses being applied to the towbar and/or the aircraft. These excessive loads may cause failure of the towbar which could cause damage to the aircraft or personal injury

### 3.0 TRAINING

#### 3.1 TRAINING REQUIREMENTS

The employer of the operator is responsible for providing a training program sufficient for the safe operation of the towbar.

#### 3.2 TRAINING PROGRAM

The employer provided operator training program should cover safety procedures concerning use of the towbar in and around the aircraft at the servicing location.

#### 3.3 OPERATOR TRAINING

The operator training should provide the required training for safe operation of the towbar.

**NOTE: Maintenance and Trouble Shooting are to be performed by the skilled and trained technician.**

### 4.0 OPERATION

#### 4.1 PRELIMINARY CHECKLIST

##### 4.1.1 Towbar

- Check weld between towing eye and tube for cracks.
- Check towing eye for bending, excessive wear and deformity.

##### 4.1.2 Towing Head

- Check welds between side rails and head rail for cracks:
- Check welds between head rail and connector tube for cracks.
- Check welds between side rails and stationary pin. Also sliding pin wear sleeve for cracks.
- Check fastener connection of towing head to towbar. Ensure the connection is not loose or missing.
- Check sliding pin ball lok-T pin. Ensure ball lok-T pin is securely attached to the side rail via its lanyard. Ensure ball lok-T pin is not missing.
- Check sliding pin for bending or excessive wear. Ensure sliding pin slides freely.
- Check sliding pin roll pin. Ensure roll pin is not loose or missing.

#### 4.2 USAGE PROCEDURE

##### 4.2.1 Aircraft Attachment



#### CAUTION!

**It is recommended that your towbar be attached to the aircraft first, and then connected to the tug to avoid possible aircraft damage.**

- Ensure the sliding pin is locked in place using the ball lok-T pin.

##### 4.2.2 Tug Attachment



#### CAUTION!

**Damage to the towbar or aircraft can result from an excessive towbar angle during towing operations. Reference Figure 1.**

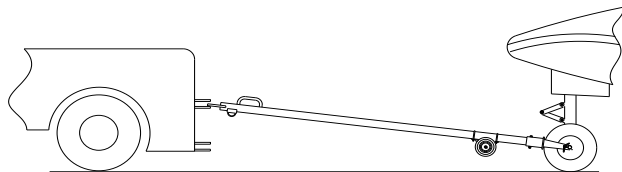

**FIGURE 1 – Incorrect**

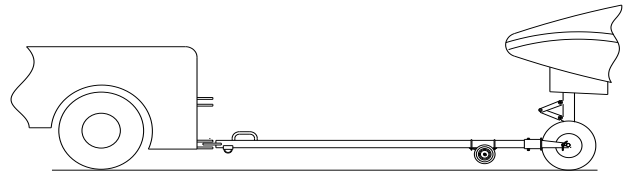

**FIGURE 2 – Correct**

- Use a pintle height so that the towbar is as level as possible during towing. Also, the pintle hook height should prevent contact of the towbar with the ground during towing.

### 4.2.3 Couplers



#### CAUTION!

Damage to the towbar or aircraft can result while towing with the following types of couplers:

- Lift Head
- Standard Duty Latch
- Vertical Side Swing Latch
- Swivel Hook

The couplers listed above are known to cause binding and failure in the eyebolt. Indicators of binding are wear on outside diameter of the eyebolt and indentation on the inside diameter of the eyebolt. **Reference Figure 3.**

Tronair recommends a telecoupler pintle hook arrangement. This arrangement is known to eliminate binding. Tronair offers a Standard Telecoupler, Model Number 01-1950-5000, for use on tugs. **Reference Figure 4.**

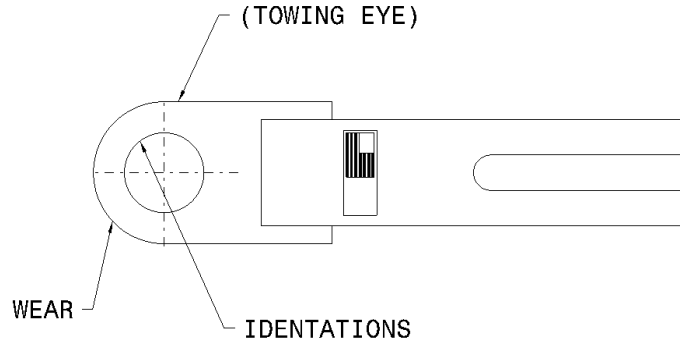

FIGURE 3

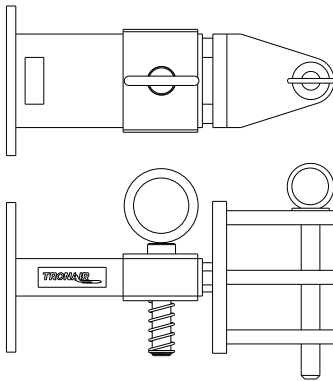

FIGURE 4

01-1950-5000 Standard Telecoupler

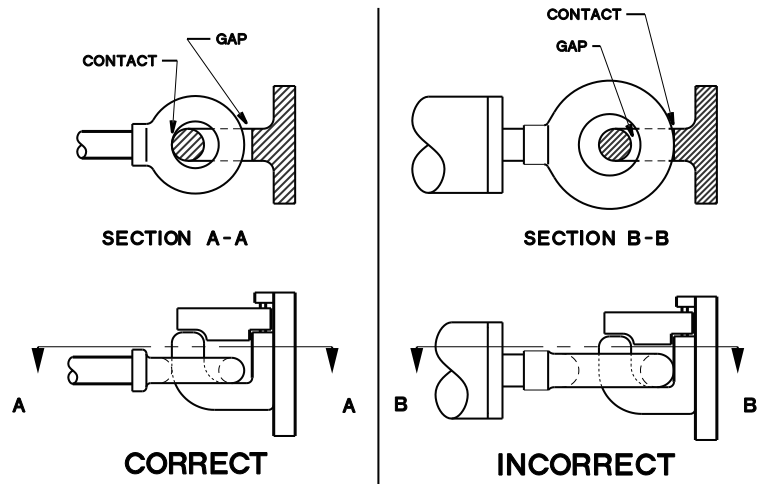

FIGURE 5

Damage to the towbar and/or aircraft can result by towing or pushing an aircraft with an incorrect size eyebolt or pintle pin. A correct size eyebolt will make contact with the pintle pin. A gap between the eyebolt outside diameter and the coupler face plate should be easily seen. An eyebolt which is too large will cause the eyebolt to make contact with the face plate of the coupler. When the eyebolt is too large for the coupler, a gap between the inside diameter of the eyebolt and the coupler face plate will be seen. **Reference Figure 5.**

To ensure proper towing and pushing, check to make sure the pintle pin diameter is not too long for the eyebolt's inside diameter. An approximate one-half inch (1/2") gap between the pin diameter and the eyebolt should be seen. If any of these conditions are not met, please contact Tronair for information to obtain a new coupler.

4.2.4 Set Sliding Pin

Set the sliding pin to the correct location using ball lok-T pin as shown in **Figures 6 – 8**.

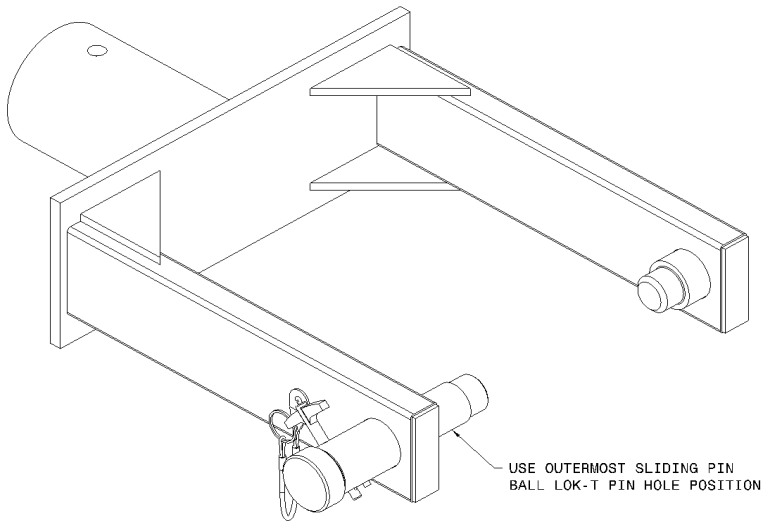

**FIGURE 6 – Sliding Pin Position for Cessna Citation**

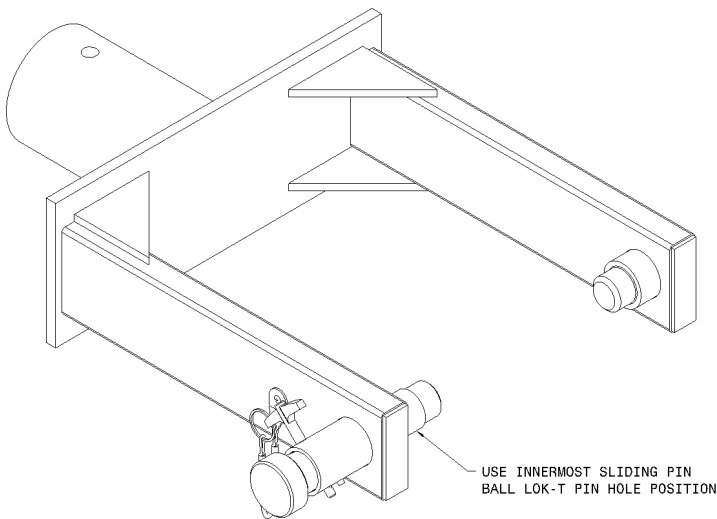

**FIGURE 7 – Sliding Pin Position for Learjet**

4.2.5 Towing Operation

Damage to the towbar or aircraft can result from pushing an aircraft while maintaining too sharp of an angle between the tug and the aircraft. Contact between the towbar weldment and the tug must be avoided. It is recommended that the angle between the tug and towbar not exceed 90°. **Reference Figure 8.**

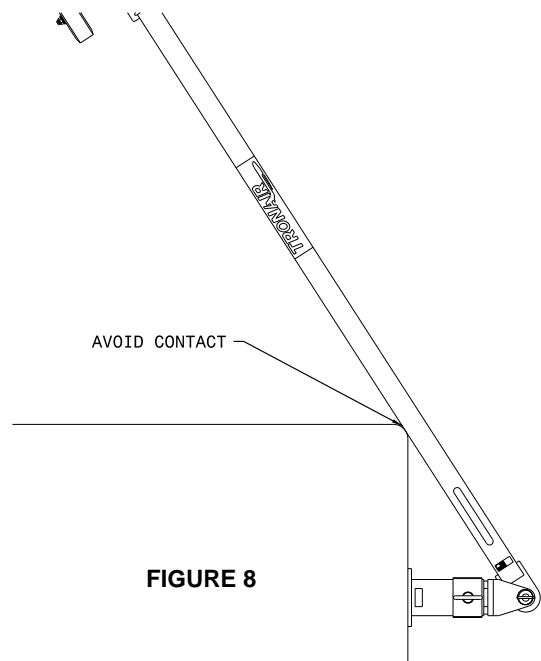

**FIGURE 8**

## 5.0 PROVISION OF SPARES

### 5.1 SOURCE OF SPARE PARTS

Spare parts may be obtained from the manufacturer:

**TRONAIR**, Inc.

1 Air Cargo Pkwy East

Swanton, Ohio 43558 USA

Telephone: (419) 866-6301 or 800-426-6301

Fax: (419) 867-0634

E-mail: sales@tronair.com

Website: www.tronair.com



For Spare Parts, Operations & Service Manuals or Service Needs:  
Scan the QR code or visit Tronair.com/aftermarket

### 5.2 RECOMMENDED SPARE PARTS LISTS

Reference the following page(s) for Replacement Parts and Kits available.

Recommended Spares to be kept on hand:

K-1308.....Kit, Ball Lok-T Pin Replacement

K-1549.....Kit, Wheel (Single) Replacement

## 6.0 IN-SERVICE SUPPORT

Contact Tronair, Inc. for technical services and information. See Section 1.3 – Manufacturer.

## 7.0 GAURANTEES/LIMITATION OF LIABILITY

Tronair products are warranted to be free of manufacturing or material defects for a period of one year after shipment to the original customer. This is solely limited to the repair or replacement of defective components. This warranty does not cover the following items:

- a) Parts required for normal maintenance
- b) Parts covered by a component manufacturers warranty
- c) Replacement parts have a 90-day warranty from date of shipment

If you have a problem that may require service, contact Tronair immediately. Do not attempt to repair or disassemble a product without first contacting Tronair, any action may affect warranty coverage. When you contact Tronair be prepared to provide the following information:

- a) Product Model Number
- b) Product Serial Number
- c) Description of the problem

If warranty coverage is approved, either replacement parts will be sent or the product will have to be returned to Tronair for repairs. If the product is to be returned, a Return Material Authorization (RMA) number will be issued for reference purposes on any shipping documents. Failure to obtain a RMA in advance of returning an item will result in a service fee. A decision on the extent of warranty coverage on returned products is reserved pending inspection at Tronair. Any shipments to Tronair must be shipped freight prepaid. Freight costs on shipments to customers will be paid by Tronair on any warranty claims only. Any unauthorized modification of the Tronair products or use of the Tronair products in violation of cautions and warnings in any manual (including updates) or safety bulletins published or delivered by Tronair will immediately void any warranty, express or implied.

The obligations of Tronair expressly stated herein are in lieu of all other warranties or conditions expressed or implied. **Any unauthorized modification of the Tronair products or use of the Tronair products in violations of cautions and warnings in any manual (including updates) or safety bulletins published or delivered by Tronair will immediately void any warranty, express or implied and Tronair disclaims any and all liability for injury (WITHOUT LIMITATION and including DEATH), loss or damage arising from or relating to such misuse.**

## 8.0 APPENDICES

APPENDIX I Declaration of Conformity



## Parts List

When ordering replacement parts/kits, please specify model, serial number and color of your unit.

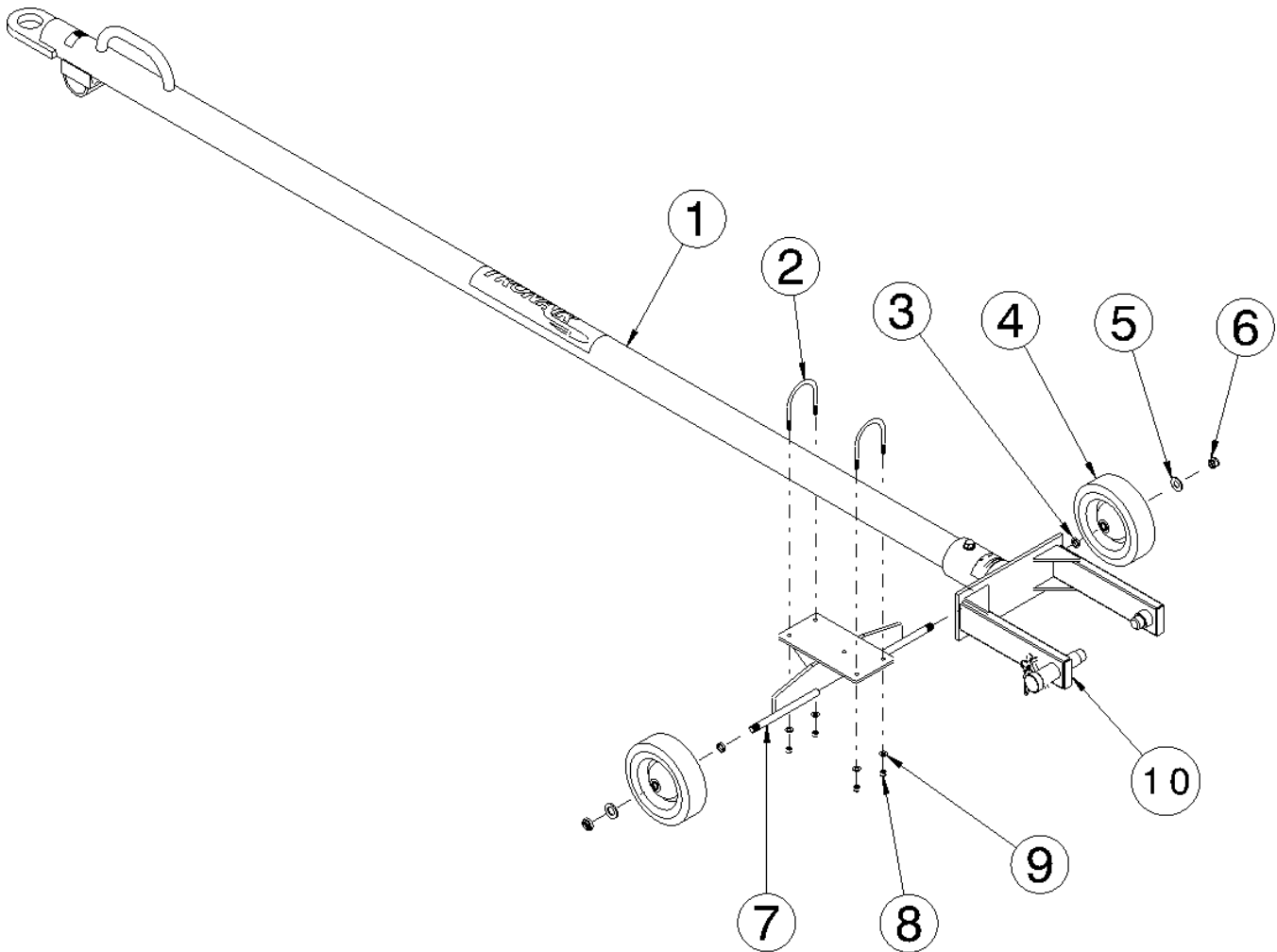

Item	Part Number	Description	Qty
1	Z-3562-02	Replacement Towbar (with Labels)	1
4	U-1001-02	Wheel	2
5	G-1250-1100N	Flatwasher, 5/8 Narrow	2
6	G-1203-1105	Stopnut, 5/8 -18 Elastic	2
10	X-1071 (See Page 7)	Assembly, Head (with Labels)	1
	<b>K-1549</b>	<b>Kit, Wheel Replacement (Single); consists of:</b>	
4	U-1001-02	Wheel	1
5	G-1250-1100N	Flatwasher, 5/8 Narrow	1
6	G-1203-1105	Stopnut, 5/8 -18 Elastic	1
	<b>K-2638</b>	<b>Kit, Wheel Bracket Replacement; consists of:</b>	
2	G-1009-37	U-Bolt	2
3	TR-1583	Spacer, Wheel	2
7	Z-3318-01	Weldment, Axle Mounting	1
9	G-1250-1060N	Flatwasher, 5/16 Narrow	4
8	G-1202-1060	Stopnut, 5/16 -18 Elastic	4

## Parts List

When ordering replacement parts/kits, please specify model, serial number and color of your unit.

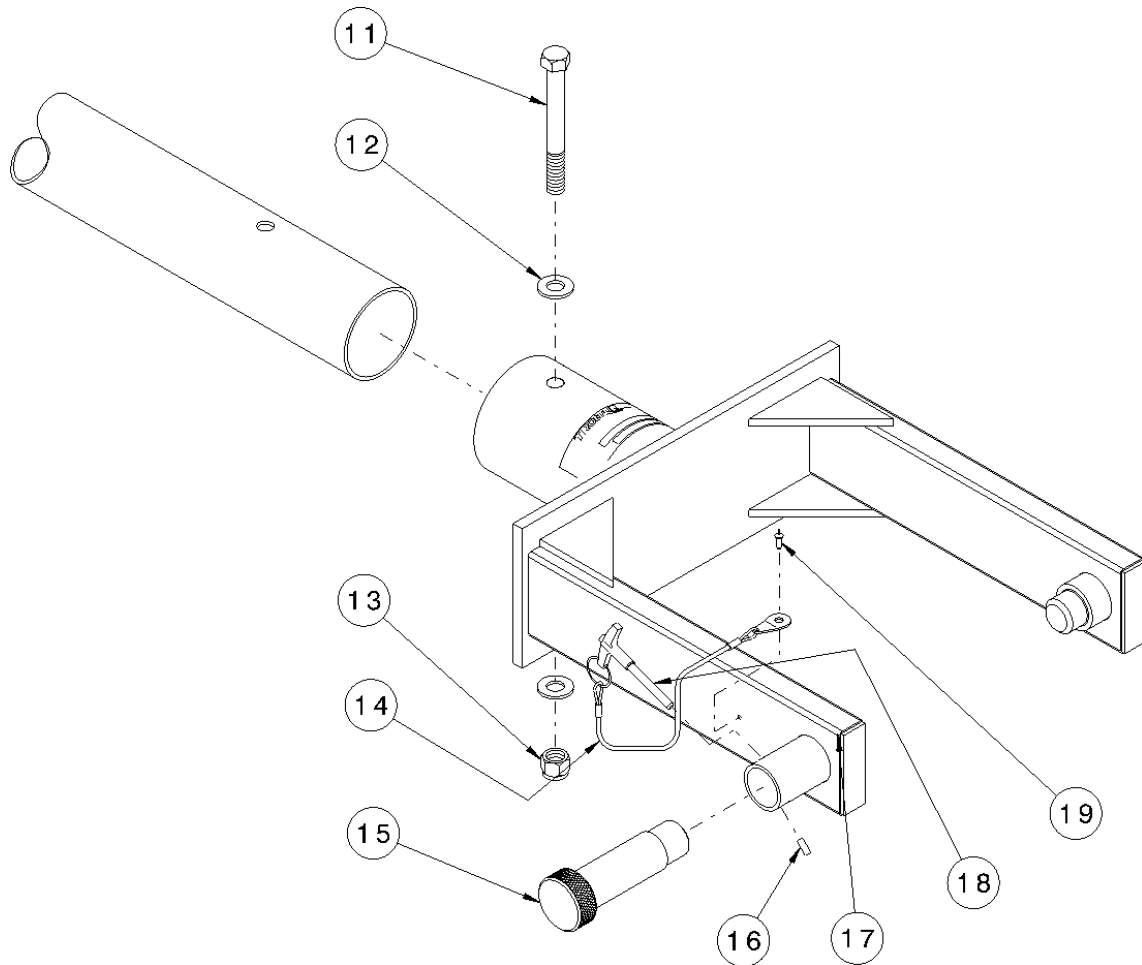

Item	Part Number	Description	Qty
17	Z-3320-01	Weldment, Head <i>(Reference Only)</i>	<i>Not Sold Separately</i>
	<b>K-1119</b>	<b>Kit, Sliding Pin Replacement; consists of:</b>	
15	R-1153	Pin, Sliding	1
16	G-1300-19040	Pin, Roll $\frac{3}{16}$ " diameter x $\frac{1}{2}$ " long	1
	<b>K-2648</b>	<b>Kit, Head Assembly Replacement; consists of:</b>	
10	X-1071	Assembly, Head with Labels	1
	<b>K-2640</b>	<b>Kit, Joining; consists of:</b>	
11	G-1100-109544	Bolt, Hex Head, Grade 5, $\frac{1}{2}$ -20 x $4\frac{1}{2}$ " long	1
12	G-1250-1090N	Flatwasher, $\frac{1}{2}$ Narrow	2
13	G-1202-1095	Stopnut, $\frac{1}{2}$ -20 Elastic	1
	<b>K-1308</b>	<b>Kit, Ball Lok-T Pin Replacement; consists of:</b>	
14	H-1026*07.0	Assembly, Lanyard, 7" long	1
18	G-1310-0415	Pin, Ball Lok-T, $\frac{1}{4}$ " diameter x $1\frac{1}{2}$ " grip	1
19	G-1351-04	Rivet, $\frac{1}{8}$ Open-end Steel	1



## **APPENDIX I**

### **Declaration of Conformity**





## DECLARATION of CONFORMITY

The design, development and manufacture is in accordance with European Community guidelines

Steel Towbar  
01-1364-0000

Relevant provisions complied with by the machinery:  
2006/42/EC

Relevant standards complied with by the machinery:  
EN ISO 12100-1

Identification of person empowered to sign on behalf of the manufacturer:

A handwritten signature in black ink that reads "Patrick Finch". The signature is written in a cursive style and is positioned above a solid horizontal line.

Quality Assurance Representative



**Tronair, Inc.**  
1 Air Cargo Pkwy East  
Swanton, OH 43558

Phone: (419) 866-6301 | 800-426-6301  
Web: [www.tronair.com](http://www.tronair.com)  
Email: [sales@tronair.com](mailto:sales@tronair.com)