

**Model: 01-1298-0000**  
**Snap-Bak Towbar**  
**Eclipse 500 Aircraft**



10/2007 – Rev. 04

**For Spare Parts, Operations & Service Manuals or Service Needs**  
**Scan the QR code or visit [Tronair.com/aftermarket](http://Tronair.com/aftermarket)**



REVISION	DATE	TEXT AFFECTED
03	04/2007	Added CE marking
04	10/2007	Modified Parts List

**TABLE OF CONTENTS**

	<b><u>PAGE</u></b>
<b>1.0 PRODUCT INFORMATION .....</b>	<b>1</b>
1.1 DESCRIPTION.....	1
1.2 MODEL & SERIAL NUMBER.....	1
1.3 MANUFACTURER.....	1
1.4 SPECIFICATIONS .....	1
<b>2.0 SAFETY INFORMATION.....</b>	<b>1</b>
2.1 GENERAL.....	1
<b>3.0 TRAINING.....</b>	<b>1</b>
3.1 TRAINING REQUIREMENTS.....	1
3.2 TRAINING PROGRAM .....	1
3.3 OPERATOR TRAINING.....	1
<b>4.0 OPERATION.....</b>	<b>2</b>
4.1 PRELIMINARY CHECKLIST.....	2
4.1.1 Towbar.....	2
4.1.2 Towing Head.....	2
4.2 USAGE PROCEDURE.....	2
4.2.1 Aircraft Attachment.....	2
4.2.2 Tug Attachment.....	2
4.2.3 Couplers.....	3
4.2.4 Towing Operation.....	3
<b>5.0 PROVISION OF SPARES.....</b>	<b>4</b>
5.1 SPARE PARTS.....	4
5.2 RECOMMENDED SPARE PARTS LISTS .....	4
<b>6.0 IN-SERVICE SUPPORT.....</b>	<b>4</b>
<b>7.0 GUARANTEES/LIMITATION OF LIABILITY.....</b>	<b>4</b>

Tronair towbars/heads must only be used with matching Tronair heads/towbars, and Tronair shear pins.

This product can not be modified without the written approval of Tronair, Inc. Any modifications done without written approval voids all warranties and releases Tronair, Inc., its suppliers, distributors, employees, or financial institutions from any liability from consequences that may occur. Only Tronair OEM replacement parts shall be used.

## 1.0 PRODUCT INFORMATION

### 1.1 DESCRIPTION

The Tronair Model 01-1298-0000 Snap-Bak Towbar is a lightweight, portable towbar for the Eclipse 500 Aircraft manufactured by Eclipse Aviation.

The snap-bak towbar includes a spring in the towing head attachment to the towbar which provides a dampening of radial forces about the aircraft nose landing gear during towing operation. The aircraft attachment is by machined pins on the towing head to the nose landing gear axle. There is a handle and an eyebolt at the end of the towbar for towing.

### 1.2 MODEL & SERIAL NUMBER

Reference nameplate on unit

### 1.3 MANUFACTURER

**TRONAIR**, Inc.  
1 Air Cargo Pkwy East  
Swanton, Ohio 43558 USA

Telephone: (419) 866-6301 or 800-426-6301  
Fax: (419) 867-0634  
E-mail: sales@tronair.com  
Website: www.tronair.com

### 1.4 SPECIFICATIONS

Aircraft Application .....Eclipse 500 manufactured by Eclipse Aviation  
Maximum Aircraft Gross Weight.....7,500 lbs (3.4 Metric ton)  
Length .....86.125 in (218.8 cm) From eyebolt centerline to aircraft attachment centerline  
Width.....13.2 in (33.5 cm)  
Height.....3.0 in (7.6 cm)  
Weight.....25 lbs (11.33 kg)

## 2.0 SAFETY INFORMATION

### 2.1 GENERAL

The Tronair Model 01-1298-0000 Snap-Bak Towbar is used for moving the Eclipse 500 Aircraft only.

To ensure safe operation, please read the following statements and understand their meaning. This manual contains safety precautions which are explained as follows. Please read carefully.



**WARNING!** Warning is used to indicate the presence of a hazard that can cause severe personal injury, death, and/or substantial property damage if the Warning Notice is ignored.

**CAUTION!** Caution is used to indicate the presence of a hazard which will or can cause minor personal injury or property damage if the Caution Notice is ignored.



### **WARNING!**

**A damaged or bent towbar should not be used. Towbar should be repaired or replaced.**

## 3.0 TRAINING

### 3.1 TRAINING REQUIREMENTS

The employer of the operator is responsible for providing a training program sufficient for the safe operation of the towbar.

### 3.2 TRAINING PROGRAM

The employer provided operator training program should cover safety procedures concerning use of the towbar in and around the Embraer 170/175/190/195 at the servicing location.

### 3.3 OPERATOR TRAINING

The operator training should provide the required training for safe operation of the towbar.

**NOTE: Maintenance and Trouble Shooting are to be performed by the skilled and trained technician.**

## 4.0 OPERATION

### 4.1 PRELIMINARY CHECKLIST

#### 4.1.1 Towbar

- Check weld between lunette and tube for cracks.
- Check lunette for bending, excessive wear and deformity.
- Check weld between tube and spring retainer for cracks.

#### 4.1.2 Towing Head

- Check welds between side rails and head rail for cracks.
- Check welds between head rail and spring retainer housing for cracks.
- Check welds between side rails and stationary pin. Also sliding pin wear sleeve for cracks.
- Check fastener connection of towing head to towbar. Ensure the connection is not loose or missing.
- Check sliding pin ball lok-T pin. Ensure ball lok-T pin is securely attached to the side rail via its lanyard. Ensure ball lok-T pin is not missing.
- Check sliding pin for bending or excessive wear. Ensure sliding pin slides freely.
- Check sliding pin roll pin. Ensure roll pin is not loose or missing.
- Check snap-bak spring. Ensure the spring is not loose or taken a set. Ensure the spring operates correctly.

## 4.2 USAGE PROCEDURE

### 4.2.1 Aircraft Attachment



#### **CAUTION!**

**It is recommended that your towbar be attached to the aircraft first, and then connected to the tug to avoid possible aircraft damage.**

- Ensure the sliding pin is locked in place using the ball lok-T pin.

### 4.2.2 Tug Attachment



#### **CAUTION!**

**Damage to the towbar or aircraft can result from an excessive towbar angle during towing operations. Reference Figure 1.**

- Use a pintle height so that the towbar is as level as possible during towing. Also, the pintle hook height should prevent contact of the towbar with the ground during towing.

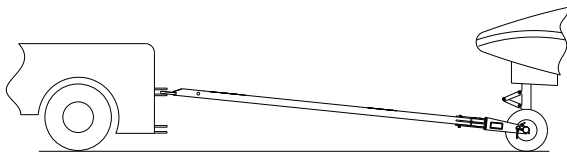

**FIGURE 1 – Incorrect**



**FIGURE 2 – Correct**

### 4.2.3 Couplers



#### CAUTION!

Damage to the towbar or aircraft can result while towing with the following types of couplers:

- Lift Head
- Standard Duty Latch
- Vertical Side Swing Latch
- Swivel Hook

The couplers listed above are known to cause binding and failure in the eyebolt. Indicators of binding are wear on outside diameter of the eyebolt and indentation on the inside diameter of the eyebolt. **Reference Figure 3.**

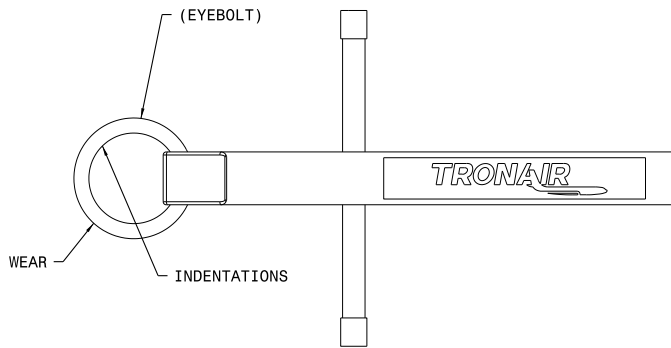

**FIGURE 3**

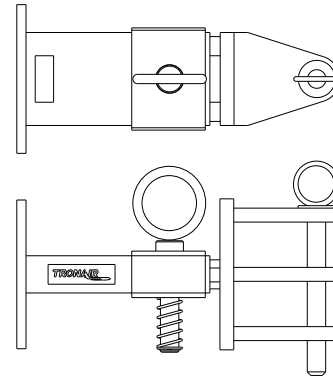
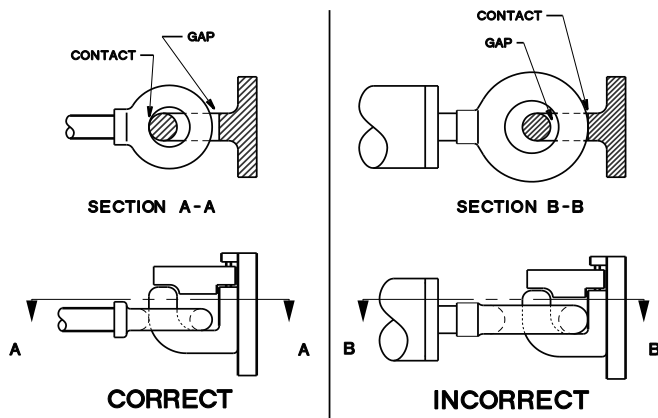

**FIGURE 4**  
**01-1950-5000 Standard Telecoupler**

Tronair recommends a telecoupler pintle hook arrangement. This arrangement is known to eliminate binding. Tronair offers a Standard Telecoupler, Model Number 01-1950-5000, for use on tugs. **Reference Figure 4.**

Damage to the towbar and/or aircraft can result by towing or pushing an aircraft with an incorrect size eyebolt or pintle pin. A correct size eyebolt will make contact with the pintle pin. A gap between the eyebolt outside diameter and the coupler face plate should be easily seen. An eyebolt which is too large will cause the eyebolt to make contact with the face plate of the coupler. When the eyebolt is too large for the coupler, a gap between the inside diameter of the eyebolt and the coupler face plate will be seen. **Reference Figure 5.**

To ensure proper towing and pushing, check to make sure the pintle pin diameter is not too long for the eyebolt's inside diameter. An approximate one-half inch (1/2") gap between the pin diameter and the eyebolt should be seen. If any of these conditions are not met, please contact Tronair for information to obtain a new coupler.



**FIGURE 5**

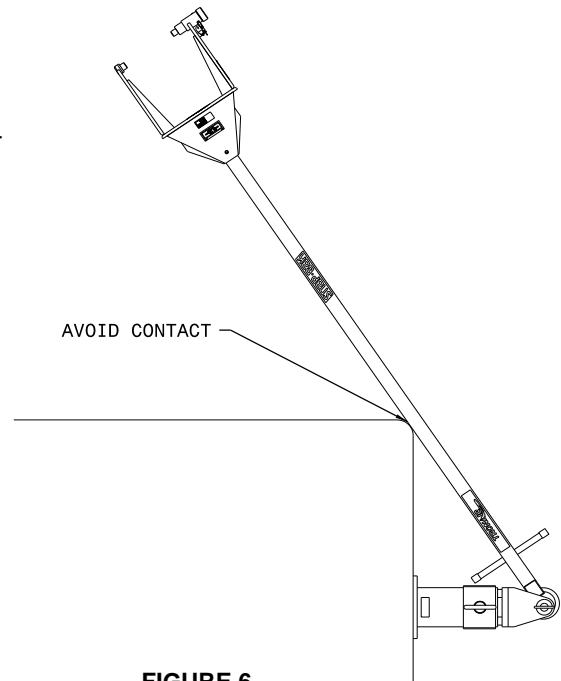

**FIGURE 6**

### 4.2.4 Towing Operation

Damage to the towbar or aircraft can result from pushing an aircraft while maintaining too sharp of an angle between the tug and the aircraft. Contact between the towbar weldment and the tug must be avoided. It is recommended that the angle between the tug and towbar not exceed 90°. **Reference Figure 6.**

**5.0 PROVISION OF SPARES**

**5.1 SPARE PARTS**

Spare parts may be obtained from the manufacturer:

<b>TRONAIR, Inc.</b>	Telephone: (419) 866-6301 or 800-426-6301
1 Air Cargo Pkwy East	Fax: (419) 867-0634
Swanton, Ohio 43558 USA	E-mail: sales@tronair.com
	Website: www.tronair.com



For Spare Parts, Operations & Service Manuals or Service Needs:  
Scan the QR code or visit Tronair.com/aftermarket

**5.2 RECOMMENDED SPARE PARTS LISTS**

Reference the following page(s) for Replacement Parts and Kits available.

Part Number	Description
K-1308	KIT, REPL. BALL LOC PIN
K-3147	KIT, PIVOT BOLT (P)
K-3718	KIT, REPL. SLIDING PIN

**6.0 IN-SERVICE SUPPORT**

Contact Tronair, Inc. for technical services and information. See Section 1.3 – Manufacturer.

**7.0 GUARANTEES/LIMITATION OF LIABILITY**

Tronair products are warranted to be free of manufacturing or material defects for a period of one year after shipment to the original customer. This is solely limited to the repair or replacement of defective components. This warranty does not cover the following items:

- a) Parts required for normal maintenance
- b) Parts covered by a component manufacturers warranty
- c) Replacement parts have a 90-day warranty from date of shipment

If you have a problem that may require service, contact Tronair immediately. Do not attempt to repair or disassemble a product without first contacting Tronair, any action may affect warranty coverage. When you contact Tronair be prepared to provide the following information:

- a) Product Model Number
- b) Product Serial Number
- c) Description of the problem

If warranty coverage is approved, either replacement parts will be sent or the product will have to be returned to Tronair for repairs. If the product is to be returned, a Return Material Authorization (RMA) number will be issued for reference purposes on any shipping documents. Failure to obtain a RMA in advance of returning an item will result in a service fee. A decision on the extent of warranty coverage on returned products is reserved pending inspection at Tronair. Any shipments to Tronair must be shipped freight prepaid. Freight costs on shipments to customers will be paid by Tronair on any warranty claims only. Any unauthorized modification of the Tronair products or use of the Tronair products in violation of cautions and warnings in any manual (including updates) or safety bulletins published or delivered by Tronair will immediately void any warranty, express or implied.

The obligations of Tronair expressly stated herein are in lieu of all other warranties or conditions expressed or implied. **Any unauthorized modification of the Tronair products or use of the Tronair products in violations of cautions and warnings in any manual (including updates) or safety bulletins published or delivered by Tronair will immediately void any warranty, express or implied and Tronair disclaims any and all liability for injury (WITHOUT LIMITATION and including DEATH), loss or damage arising from or relating to such misuse.**

## Parts List

When ordering replacement parts/kits, please specify model, serial number and color of your unit.

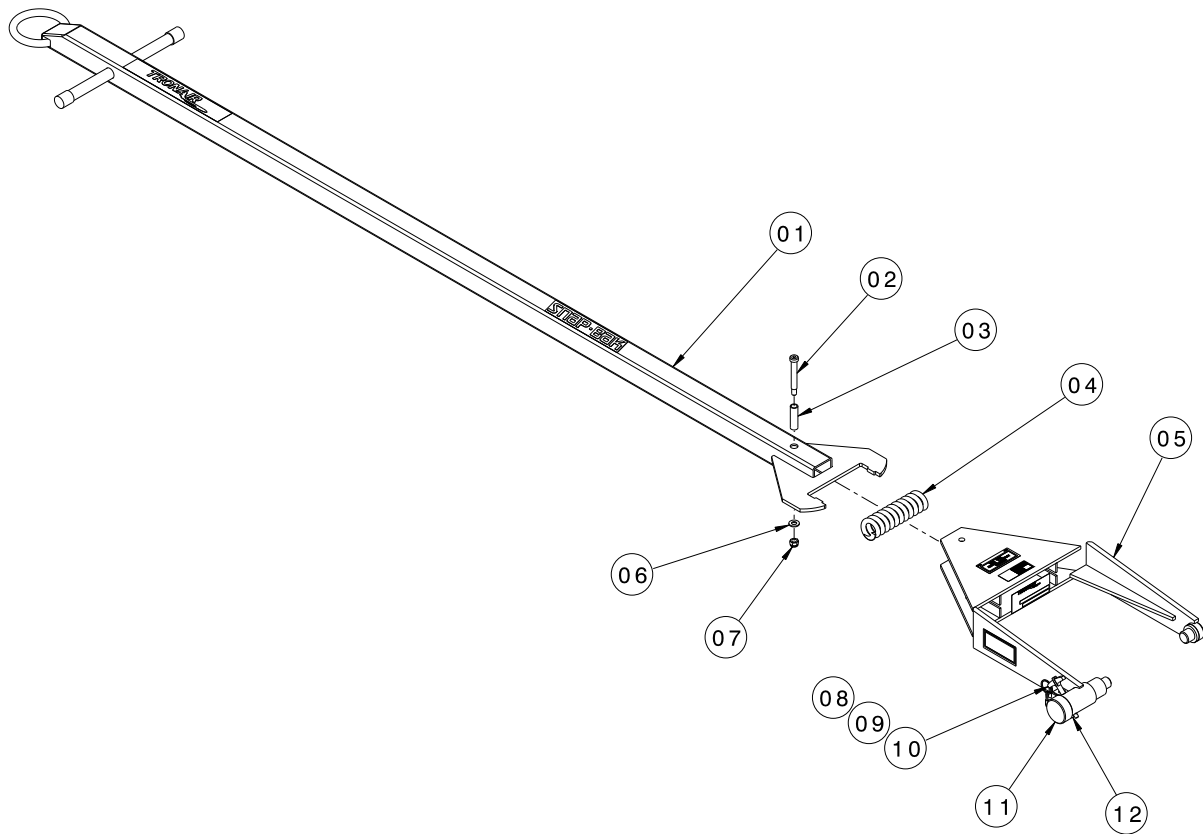

Item	Part Number	Description	Qty
1	Y-1002-01	Assembly, Towbar	1
2	G-1155-106222	Screw, Socket Head Shoulder, 5/16-18, 3/8" diameter x 2¼" long	1
3	TR-1672-01	Sleeve	1
4	H-3080	Spring	1
5	X-1131	Assembly, Head	1
6	G-1250-1060N	Flatwasher, 5/16 Narrow	1
7	G-1202-1060	Stopnut, 5/16 Elastic	1
11	R-2101	Sliding Pin	1
12	G-1300-19040	Roll Pin, 3/16" diameter x 1/2" long	1
	<b>K-1308</b>	<b>Kit, Ball Lok-T Pin Replacement; consists of:</b>	
8	G-1351-04	Rivet, 1/8 Open-end Steel	1
9	H-1026*07.0	Assembly, Lanyard	1
10	G-1310-0415	Ball Lok-T Pin, ¼" diameter x 1.5" Grip	1
	<b>K-3147</b>	<b>Kit, Pivot Bolt Replacement; consists of:</b>	
2	G-1155-106222	Screw, Socket Head Shoulder, 5/16-18, 3/8" diameter x 2¼" long	1
3	TR-1672-01	Sleeve	1
6	G-1250-1060N	Flatwasher, 5/16 Narrow	1
7	G-1202-1060	Stopnut, 5/16 Elastic	1
	<b>K-3718</b>	<b>Kit, Sliding Pin Replacement; consists of:</b>	
11	R-2101	Sliding Pin	1
12	G-1300-19040	Roll Pin, 3/16" diameter x 1/2" long	1





## **APPENDIX I**

### **Declaration of Conformity**





# EU Declaration of Conformity

**Model Number(s)** 01-1297-0100, 01A1297-0100, 01B1297-0100

**Product Type/Name:** Custom Towbar

**Serial Number(s):** Enter serial number(s)

**Declaration:** Tronair has assessed the equipment described above against the Essential Health and Safety Requirements of one or more Directives. Based on this assessment, the equipment described above is deemed to comply with the directive(s) listed below.

This declaration of conformity is issued under the sole responsibility of the manufacturer.

**Directives:** European Machinery Directive 2006/42/EC

**Standards:** EN ISO 12100:2011 Safety of machinery – General principles for design – Risk assessment and risk reduction

**Markings:** 

**The technical documentation for the machinery is available from:**

Mr. Joel Nunn  
34 Epirus Road, SW6 7UH, London, UK  
Email: [jnunn@tronair.com](mailto:jnunn@tronair.com)

**Location of Issue:** Tronair, 1 Air Cargo Parkway East, Swanton, OH 43558

**Certificate:** EU\_DoC\_01-1297-0100, 01A1297-0100, 01B1297-0100

**Identification of person empowered to sign on behalf of the Manufacturer:**

  
Quality Assurance Representative

Enter a date

Date





### Snapbak Towbars

**Models:**

01-1109-0000, 01-1109-0010, 01-1112-0000, 01-1112-0010, 01-1142-0000,  
01-1170-0000, 01-1170-0010, 01-1179-0000, 01-1179-0010, 01-1233-0000,  
01-1233-0010, 01-1233-0011, 01-1273-0000, 01-1273-0010, 01-1283-0000,  
01-1298-0000

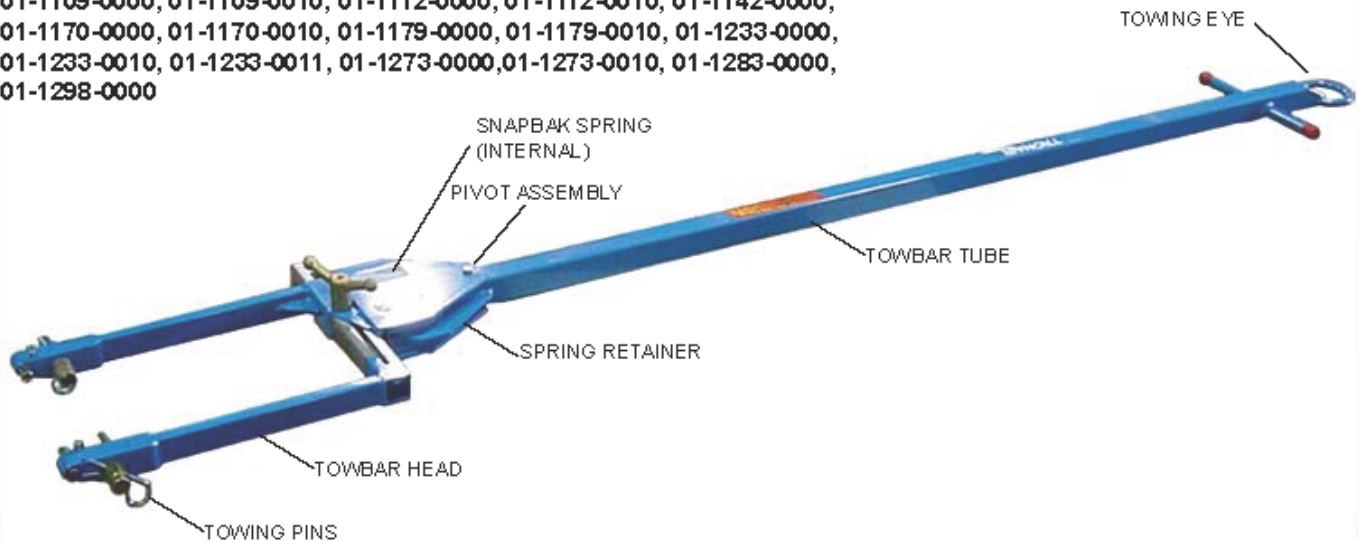

**Tronair recommends towbar inspections at least once a week.**

- Check towing eye for bending, excessive wear and deformity. If any are located, remove towbar from service and contact Tronair for repair.
- Inspect the towbar tube for cracks, gouges greater than 1/32", and bends or deformities. If any are located, remove towbar from service and contact Tronair or your Tronair distributor for replacement.
- Check the snapbak pivot assembly. Ensure the pivot assembly is not loose or missing. Tighten or replace as required.
- Check the snapbak spring by holding the towing head section in a vise and from the towing eye end rotate the towbar tube side to side, approximately 15° in each direction. The snapbak spring should re-center the towbar tube. If it does not, disassemble the snapbak pivot assembly and check that the snapbak spring is positioned within the spring retainer. If it is not, reposition the snapbak spring and retest. If the spring is in position, contact Tronair or your Tronair distributor for snapbak spring replacement.
- Inspect all welds on the towbar head and towbar tube for cracks. If any weld cracks are located, remove towbar from service and contact Tronair for repair.
- Check towing pins for bending, cracks and excessive wear. If any are located, remove towbar from service and contact Tronair or your Tronair distributor for replacement.
- Check towbar head members for bending and cracks. If any are located, remove towbar from service and contact Tronair or your Tronair distributor for replacement.
- Inspect all steel components for signs of rust. Touch up with paint as required.

INS-1787

[www.tronair.com](http://www.tronair.com)

Tronair • Email: [sales@tronair.com](mailto:sales@tronair.com) • Phone: 419-866-6301 or 800-426-6301 • Fax: 419-867-0634

Asia Sales Offices: China - Email: [tronairchina@tronair.com](mailto:tronairchina@tronair.com) • Phone: 86-592-5560735 • Fax: 86-592-5563132

Asia/Australia - Email: [tronairasia@tronair.com](mailto:tronairasia@tronair.com) • Phone: 66-2665-6511 • Fax: 66-2204-1858

Europe, Middle East & Africa Sales Office • Email: [saleseurope@tronair.com](mailto:saleseurope@tronair.com) • Phone: 44-0-113-245-3300 • Fax: 44-0-113-322-0436