

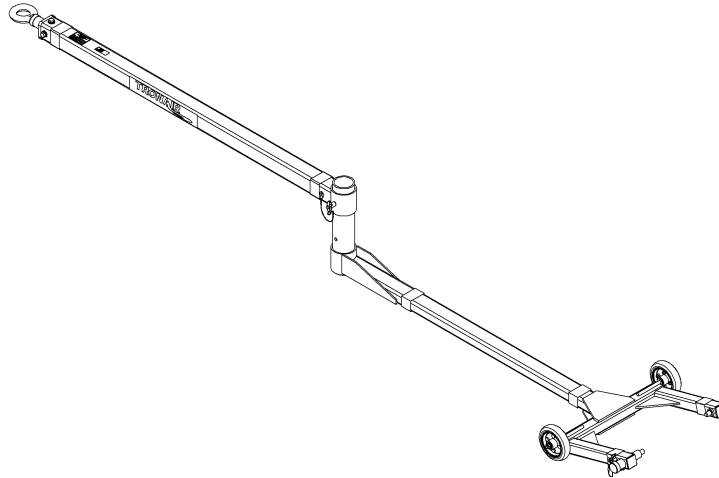

Operation & Service Manual



Model: 01-1372-0000
Bell 525 Towbar



03/2010 – Rev. 01

When ordering Replacement Parts/Kits, please specify Model & Serial Number of your Unit.

REVISION
01

DATE
01/2016

TEXT AFFECTED
Original release

TABLE OF CONTENTS

	<u>PAGE</u>
1.0 PRODUCT INFORMATION	1
1.1 DESCRIPTION	1
1.2 MODEL & SERIAL NUMBER	1
1.3 MANUFACTURER.....	1
1.4 SPECIFICATIONS.....	1
2.0 SAFETY INFORMATION.....	1
2.1 GENERAL	1
3.0 TRAINING.....	1
3.1 TRAINING REQUIREMENTS.....	1
3.2 TRAINING PROGRAM.....	1
3.3 OPERATOR TRAINING	1
4.0 OPERATION.....	2
4.1 TOWBAR CHECKLIST.....	2
4.2 USAGE PROCEDURE	2
4.2.1 Aircraft Attachment.....	2
4.2.2 Couplers	2
4.2.3 Towing Operation	3
5.0 PROVISION OF SPARES	3
5.1 SOURCE OF SPARE PARTS	3
5.2 RECOMMENDED SPARE PARTS LISTS.....	3
6.0 IN-SERVICE SUPPORT	3
7.0 GUARANTEES/LIMITATION OF LIABILITY	4

Tronair towbars/heads must only be used with matching Tronair heads/towbars, and Tronair shear pins.

This product can not be modified without the written approval of Tronair, Inc. Any modifications done without written approval voids all warranties and releases Tronair, Inc., its suppliers, distributors, employees, or financial institutions from any liability from consequences that may occur. Only Tronair OEM replacement parts shall be used.

1.0 PRODUCT INFORMATION

1.1 DESCRIPTION

The Tronair Model 01-1372-0000 towbar is for use with Bell 525 Aircraft manufactured by Bell Helicopter.

The towbar includes solid tires. There is an eyebolt at the towing end of the towbar. The aircraft attachment is by machined pins on the towing head to the aircraft tow point.

1.2 MODEL & SERIAL NUMBER

Reference nameplate on unit

1.3 MANUFACTURER

TRONAIR, Inc.
1740 Eber Road
Holland, Ohio 43528-9794 USA

Telephone: (419) 866-6301 or 800-426-6301
Fax: (419) 867-0634
E-mail: sales@tronair.com
Website: www.tronair.com

1.4 SPECIFICATIONS

Application: Bell 525 Aircraft manufactured by Bell Helicopter

Maximum Aircraft Gross Weight: 19,300 lbs (8.8 Metric ton)

Dimensions: Length 145.437 in (369.4 cm) From eyebolt centerline to end of towbar

Width 28.01 in (71.2 cm)

Height 15.37 in (39 cm) diameter

Weight: 206.5 lbs (90 kg)

Finish: Powder Coat

Material: Steel

2.0 SAFETY INFORMATION

2.1 GENERAL

The Tronair Model 01-1372-0000 towbar is used for moving Bell 525 Aircraft only.

To insure safe operations please read the following statements and understand their meaning. Also refer to your equipment manufacturer's manual for other important safety information. This manual contains safety precautions which are explained below. Please read carefully.



WARNING! Warning is used to indicate the presence of a hazard that can cause **severe personal injury, death, and/or substantial property damage** if the Warning Notice is ignored.

CAUTION! Caution is used to indicate the presence of a hazard which will or can cause **minor personal injury or property damage** if the Caution Notice is ignored.

3.0 TRAINING

3.1 TRAINING REQUIREMENTS

The employer of the operator is responsible for providing a training program sufficient for the safe operation of the towbar.

3.2 TRAINING PROGRAM

The employer provided operator training program should cover safety procedures concerning use of the towbar in and around the aircraft at the servicing location.

3.3 OPERATOR TRAINING

The operator training should provide the required training for safe operation of the towbar.

NOTE: Maintenance and Trouble Shooting are to be performed by the skilled and trained technician.

4.0 OPERATION

4.1 TOWBAR CHECKLIST

- Check towing eye for bending, excessive wear and/or deformity. Contact Tronair for repair/replacement if towing eye is bent, excessively worn or deformed.
- Inspect the towbar tube for cracks, gouges greater than 1/16 inch, and bends or deformities. A damaged or bent towbar should not be used. Contact Tronair for replacement.



WARNING!

A damaged or bent towbar should not be used. Towbar should be repaired or replaced.



WARNING!

Tronair recommends that towbars be used with the same category determined for the tug as the category designated for the aircraft in accordance with AHM 955 "Functional specifications for an aircraft tractor" Using a category 2 tug is permissible but may result in excessive loads and stresses being applied to the towbar and/or the aircraft if appropriate safety and handling precautions are not followed. These excessive loads may cause failure of the towbar which could cause damage to the aircraft or personal injury.

4.2 USAGE PROCEDURE

4.2.1 Aircraft Attachment



CAUTION!

It is recommended that your towbar to attached to the aircraft first, and then connected to the tug to avoid possible aircraft damage.

4.2.2 Couplers



CAUTION!

Damage to the towbar or aircraft can result while towing with the following types of couplers:

- Lift Head
- Standard Duty Latch
- Vertical Side Swing Latch
- Swivel Hook

The couplers listed above are known to cause binding and failure in the lunette eye. Indicators of binding are wear on outside diameter of the eyebolt and indentation on the inside diameter of the eyebolt. **Reference Figure 2.**

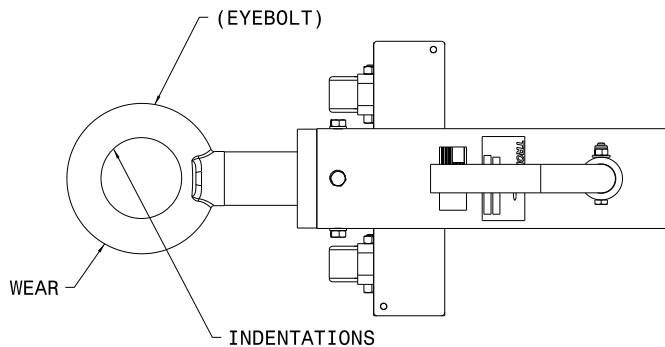

FIGURE 2

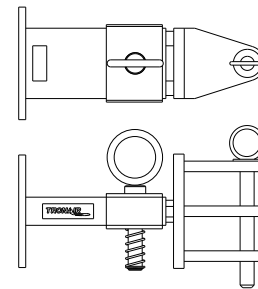

FIGURE 3
01-1950-5000 Standard Telecoupler

Tronair recommends a telecoupler pintle hook arrangement. This arrangement is known to eliminate binding. Tronair offers a Standard Telecoupler, Model Number 01-1950-5000, for use on tugs. **Reference Figure 3.**

4.2.2 Couplers continued on following page.

3.2.2 Couplers (continued)

Damage to the towbar and/or aircraft can result by towing or pushing an aircraft with an incorrect size eyebolt or pintle pin. A correct size eyebolt will make contact with the pintle pin. A gap between the eyebolt outside diameter and the coupler face plate should be easily seen. An eyebolt which is too large will cause the eyebolt to make contact with the face plate of the coupler. When the eyebolt is too large for the coupler, a gap between the inside diameter of the eyebolt and the coupler face plate will be seen. **Reference Figure 4.**

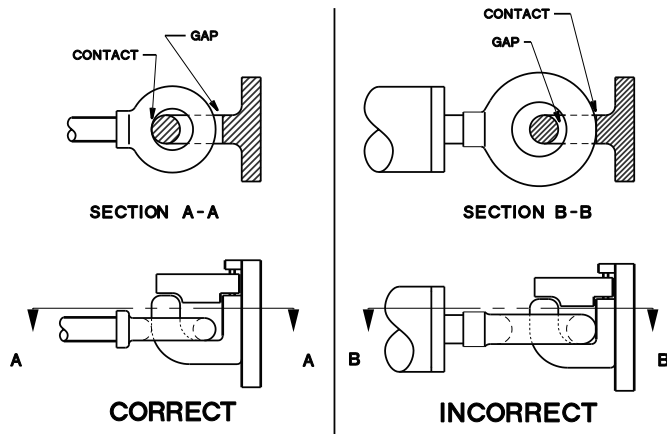

FIGURE 4

To ensure proper towing and pushing, check to make sure the pintle pin diameter is not too long for the eyebolt's inside diameter. An approximate one-half inch (1/2") gap between the pin diameter and the eyebolt should be seen. If any of these conditions are not met, please contact Tronair for information to obtain a new coupler.

3.2.3 Towing Operation

Damage to the towbar or aircraft can result from pushing an aircraft while maintaining too sharp of an angle between the tug and the aircraft. Contact between the towbar weldment and the tug must be avoided. It is recommended that the angle between the tug and towbar not exceed 90°. **Reference Figure 5.**

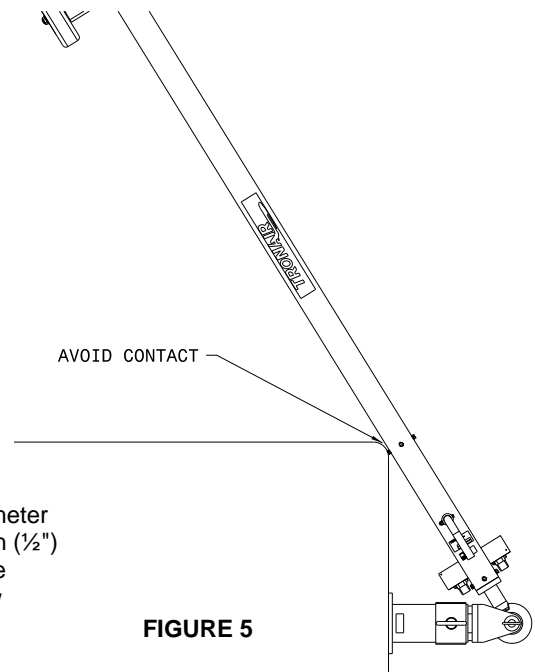

FIGURE 5

5.0 PROVISION OF SPARES

5.1 SOURCE OF SPARE PARTS

Spare parts may be obtained from the manufacturer:

TRONAIR, Inc.
1740 Eber Road
Holland, Ohio 43528-9794 USA

Telephone: (419) 866-6301 or 800-426-6301
Fax: (419) 867-0634
E-mail: sales@tronair.com
Website: www.tronair.com

5.2 RECOMMENDED SPARE PARTS LISTS

Reference the following page(s) for Replacement Parts and Kits available.

6.0 IN-SERVICE SUPPORT

Contact Tronair, Inc. for technical services and information. See Section 1.3 – Manufacturer.

7.0 GUARANTEES/LIMITATION OF LIABILITY

Tronair products are warranted to be free of manufacturing or material defects for a period of one year after shipment to the original customer. This is solely limited to the repair or replacement of defective components. This warranty does not cover the following items:

- a) Parts required for normal maintenance
- b) Parts covered by a component manufacturers warranty
- c) Replacement parts have a 90-day warranty from date of shipment

If you have a problem that may require service, contact Tronair immediately. Do not attempt to repair or disassemble a product without first contacting Tronair, any action may affect warranty coverage. When you contact Tronair be prepared to provide the following information:

- a) Product Model Number
- b) Product Serial Number
- c) Description of the problem

If warranty coverage is approved, either replacement parts will be sent or the product will have to be returned to Tronair for repairs. If the product is to be returned, a Return Material Authorization (RMA) number will be issued for reference purposes on any shipping documents. Failure to obtain a RMA in advance of returning an item will result in a service fee. A decision on the extent of warranty coverage on returned products is reserved pending inspection at Tronair. Any shipments to Tronair must be shipped freight prepaid. Freight costs on shipments to customers will be paid by Tronair on any warranty claims only. Any unauthorized modification of the Tronair products or use of the Tronair products in violation of cautions and warnings in any manual (including updates) or safety bulletins published or delivered by Tronair will immediately void any warranty, express or implied.

The obligations of Tronair expressly stated herein are in lieu of all other warranties or conditions expressed or implied. **Any unauthorized modification of the Tronair products or use of the Tronair products in violations of cautions and warnings in any manual (including updates) or safety bulletins published or delivered by Tronair will immediately void any warranty, express or implied and Tronair disclaims any and all liability for injury (WITHOUT LIMITATION and including DEATH), loss or damage arising from or relating to such misuse.**

Parts List Illustrations

When ordering replacement parts/kits, please specify model, serial number and color of your unit.

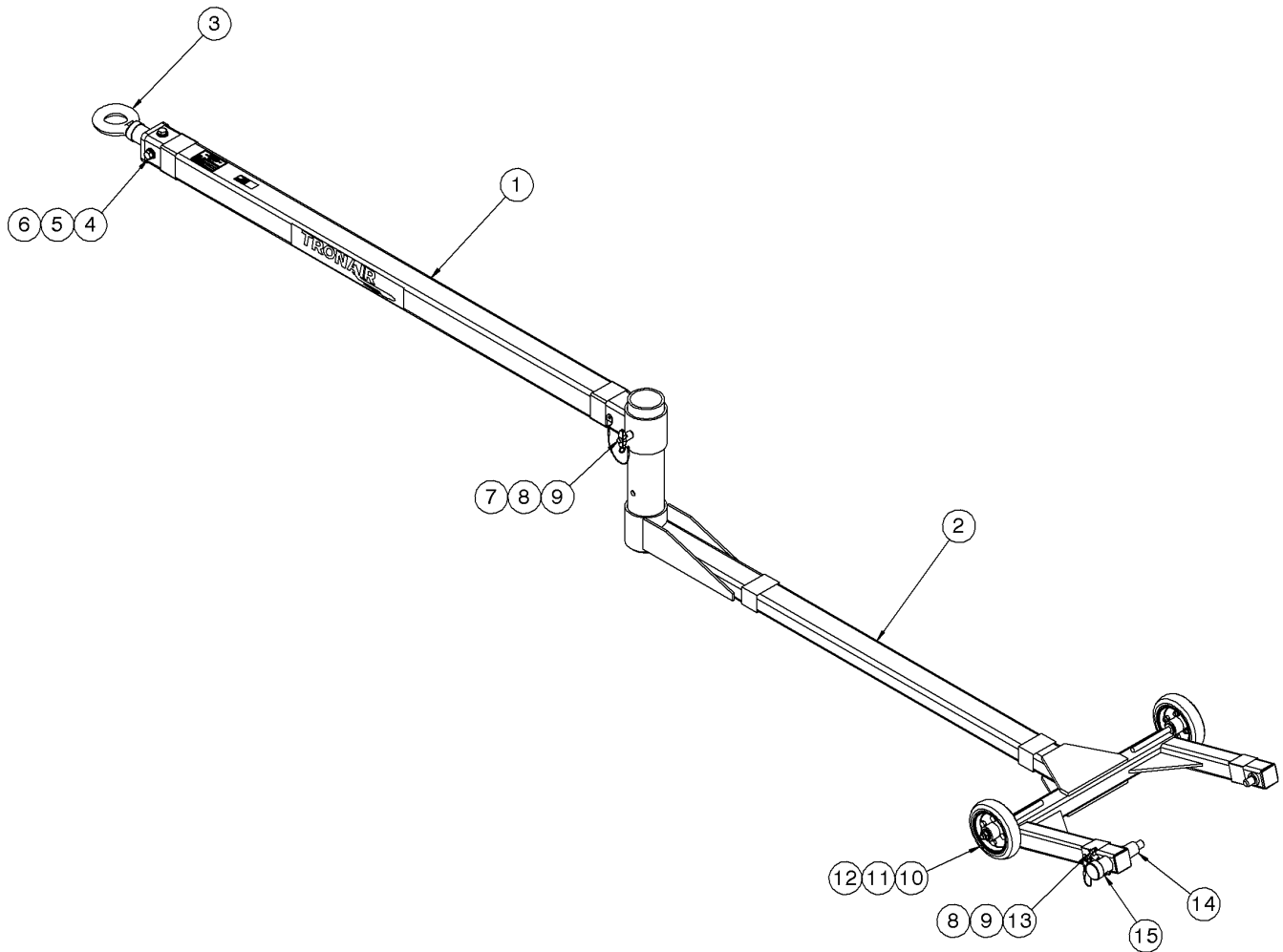

ITEM	PART NUMBER	DESCRIPTION	QTY
1	Z-8303	Weldment, Extension	1
2	Z-9010-01	Weldment, Head	1
3	Z-8305	Weldment, Eyebolt	1
4	G-1250-1090N	Flatwasher, ½ Narrow	4
5	G-1251-1090R	Lockwasher, ½ Regular	4
6	G-1100-109510	Bolt, ½ - 20 X 1.0" Hex Head Grade 5	4
7	G-1310-0840	Pin, ½ x 4.0 Ball Lok-T	1
8	H-1026*07.0	Assembly, Lanyard	2
9	G-1352-07	Rivet, ⅓ Open-End Steel	2
10	U-1169	Wheel, 6" Solid	2
11	G-1250-1090N	Flatwasher, ½ Narrow	4
12	G-1203-1095	Jamnut, ½ - 20 Elastic	2
13	G-1310-0415	Pin, ¼ x 1.5 Ball Lok-T	1
14	R-2832	Pin, Sliding	1
15	G-1150-103503	Screw, Hex Head Machine, #10 - 32 x ⅝" Long	1



APPENDIX - I

**Declaration
of
Conformity**



DECLARATION of CONFORMITY

The design, development and manufacture is in accordance with European Community guidelines

Towbar
01-1372-0000

Relevant provisions complied with by the machinery:
2006/42/EC

Relevant standards complied with by the machinery:
EN ISO 12100-1

Identification of person empowered to sign on behalf of the manufacturer:

A handwritten signature in black ink, reading "David L. Kiehl", is written over a horizontal line.

Quality Assurance Representative