

Model: 01-1376-0000
Custom Towbar



01/2023 - Rev. 02

For Spare Parts, Operations & Service Manuals or Service Needs
Scan the QR code or visit Tronair.com/aftermarket



REVISION	DATE	TEXT AFFECTED
01	07/2014	Original release
02	01/2023	Major revision

TABLE OF CONTENTS

PAGE

1.0	PRODUCT INFORMATION	1
1.1	DESCRIPTION.....	1
1.2	MODEL & SERIAL NUMBER.....	1
1.3	MANUFACTURER.....	1
1.4	SPECIFICATIONS	1
2.0	SAFETY INFORMATION.....	1
2.1	USAGE AND SAFETY INFORMATION.....	1
3.0	TRAINING.....	1
3.1	TRAINING REQUIREMENTS.....	1
3.2	TRAINING PROGRAM.....	1
3.3	OPERATOR TRAINING.....	1
4.0	OPERATION.....	2
4.1	LANDING GEAR ASSEMBLY.....	2
4.2	TOWBAR CHECKLIST.....	2
4.3	USAGE PROCEDURE.....	3
4.3.1	Aircraft Attachment.....	3
4.2.2	Head Attachment.....	3
4.3.3	Tug Attachment.....	3
4.3.4	Couplers.....	3
4.3.4	Couplers (<i>continued</i>).....	4
4.2.5	Towing Operation.....	4
5.0	PROVISION OF SPARES.....	5
10.1	SOURCE OF SPARE PARTS.....	5
10.2	RECOMMENDED SPARE PARTS LISTS.....	5
6.0	IN-SERVICE SUPPORT.....	5
7.0	GUARANTEES/LIMITATION OF LIABILITY.....	5

Tronair towbars/heads must only be used with matching Tronair heads/towbars, and Tronair shear pins.

This product can not be modified without the written approval of Tronair, Inc. Any modifications done without written approval voids all warranties and releases Tronair, Inc., its suppliers, distributors, employees, or financial institutions from any liability from consequences that may occur. Only Tronair OEM replacement parts shall be used.

1.0 PRODUCT INFORMATION

1.1 DESCRIPTION

The Tronair Model 01-1376-0000 Custom Towbar is designed for the Bell 525 Rotorcraft manufactured by Bell.

1.2 MODEL & SERIAL NUMBER

Reference nameplate on unit

1.3 MANUFACTURER

TRONAIR, Inc.

1 Air Cargo Pkwy East
Swanton, Ohio 43558 USA

Telephone: (419) 866-6301 or 800-426-6301

Fax: (419) 867-0634

E-mail: sales@tronair.com

Website: www.tronair.com

1.4 SPECIFICATIONS

Application: 525 manufactured by Bell

Maximum Aircraft Gross Weight.....21,000 lbs (9.5 Metric ton)

Length143 7/16 in (364.3cm) From eyebolt centerline to end of towbar

Width23 in (58.4 cm)

Height25 in (63.5 cm)

Tube3 ½ in (8.9 cm) diameter

Weight116.8 lbs (53 kg)

Finish.....Powder Coat

2.0 SAFETY INFORMATION

2.1 USAGE AND SAFETY INFORMATION

The Tronair Model 01-1376-0000 Custom Towbar is used for towing the Bell 525 Rotorcraft only.

To ensure safe operation, please read the following statements and understand their meaning. This manual contains safety precautions which are explained as follows. Please read carefully.



WARNING! Warning is used to indicate the presence of a hazard that can cause **severe personal injury, death, and/or substantial property damage** if the Warning Notice is ignored.

CAUTION! Caution is used to indicate the presence of a hazard which will or can cause **minor personal injury or property damage** if the Caution Notice is ignored.

3.0 TRAINING

3.1 TRAINING REQUIREMENTS

The employer of the operator is responsible for providing a training program sufficient for the safe operation of the towbar.

3.2 TRAINING PROGRAM

The employer provided operator training program should cover safety procedures concerning use of the towbar in and around the aircraft at the servicing location.

3.3 OPERATOR TRAINING

The operator training should provide the required training for safe operation of the towbar.

NOTE: Maintenance and Trouble Shooting are to be performed by the skilled and trained technician.

4.0 OPERATION**4.1 LANDING GEAR ASSEMBLY**

Place landing gear assembly in desired location. Torque clamp nuts to 35 ft-lbs (47.5 N-m)

4.2 TOWBAR CHECKLIST

- Towbar:
- Check towing eye for bending, excessive wear and/or deformity. Contact Tronair for repair/replacement if towing eye is bent, excessively worn or deformed.
- Check towing eye mounting bolts. Ensure fasteners are not loose or missing. Tighten to 25 ft-lbs or replace as required.
- Ensure that the towing eye does not turn; if the towing eye can turn it indicates that the centering pin within the shock assembly may have been broken and repairs are needed.
- Check the shock assembly for preload on the spring by pulling on the towing eye. If the shock can be moved by hand it indicates that the spring is worn out and Tronair should be contacted for repairs.
- Inspect the towbar tube for cracks, gouges greater than 1/16 inch, and bends or deformities. A damaged or bent towbar should not be used. Contact Tronair for replacement.
- Check the casters to ensure the swivels operate freely and the bearings are not missing. Replace if needed.
- Ensure that the caster mounting fasteners are not loose or missing. Tighten or replace as required.
- Check the caster mounting plate and channel. If the caster mounting plate is bent or broken or if the channel welds are broken, contact Tronair for repairs.
- Inspect the lifting handle at the towing eye end. Replace or repair the handle if it is missing or damaged. Ensure the mounting fasteners are not loose or missing. Tighten or replace as required.
- Check the towbar undercarriage. Inflate the pneumatic tires to the proper pressure; fix any air leaks or replace if needed, ensure the wheels can rotate freely, wheel rims are not bent, and tire axle is not bent. Ensure mounting fasteners are not loose or missing; tighten or replace as required. Grease the tire axle every 90 days to 6 months.
- Inspect towing head attachment ball loc pin. Verify that the factory supplied ball loc pin is used; contact Tronair for replacement if required. Do not substitute without Tronair approval.

Head Attachment Weldment:

- Check weld between connector tube and head plate for cracks.
- Check weld between side rails and head plate for cracks.
- Check weld between side rail and stationary pin for cracks.
- Check weld between side rail and sliding pin sleeve for cracks.

Sliding Pin:

- Check sliding pin for bending or excessive wear. Ensure sliding pin slides freely.
- Check sliding pin ball lok-T pin. Ensure ball lok-T pin is securely attached to the head attachment via its lanyard.
- Ensure ball lok-T pin is not loose or missing.

**WARNING!**

A damaged or bent towbar should not be used. Towbar should be repaired or replaced.

**WARNING!**

Tronair recommends the use of a towbar with a category 1 or category 2 tug and aircraft not exceeding 75,000 lbs gross weight. Using the towbar with aircraft weighing in excess of this specific limitation may result in excessive loads and stresses being applied to the towbar and/or the aircraft. These excessive loads may cause failure of the towbar which could cause damage (INCLUDING WITHOUT LIMITATION to the aircraft) and/or personal injury OR DEATH. TRONAIR MAKES NO REPRESENTATION, WARRANTY OR GUARANTEE AS TO SUCH MISUSE AND DISCLAIMS ANY AND ALL LIABILITY FOR INJURY, LOSS OR DAMAGE ARISING FROM OR RELATING TO SUCH MISUSE.

4.3 USAGE PROCEDURE

4.3.1 Aircraft Attachment



CAUTION!

It is recommended that your towbar be attached to the aircraft first, and then connected to the tug to avoid possible aircraft damage.

4.3.2 Head Attachment

Secure the towbar head attachment using the ball lok-T pin (supplied with the custom towbar) onto the towbar.

- Ensure the sliding pin is locked in place using the ball lok-T pin.

4.3.3 Tug Attachment



CAUTION!

Damage to the towbar or aircraft can result from an excessive towbar angle during towing operations. Reference Figure 1.

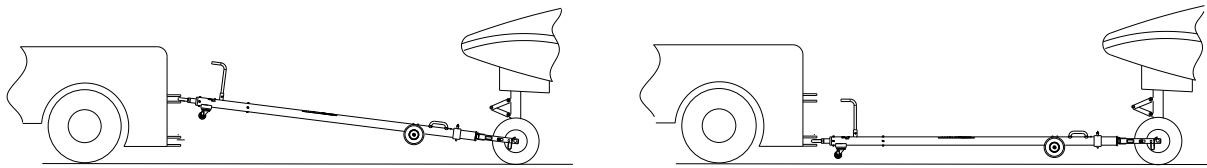

**Incorrect
(Excessive Towbar Angle)**

Correct

FIGURE 1

- Use a pintle height so that the towbar is as level as possible during towing. Also, the pintle hook height should prevent contact of the towbar with the ground during towing.

4.3.4 Couplers



CAUTION!

Damage to the towbar or aircraft can result while towing with the following types of couplers:

- Lift Head
- Vertical Side Swing Latch
- Standard Duty Latch
- Swivel Hook

The couplers listed above are known to cause binding and failure in the lunette eye. Indicators of binding are wear on outside diameter of the eyebolt and indentation on the inside diameter of the eyebolt. Reference Figure 2.

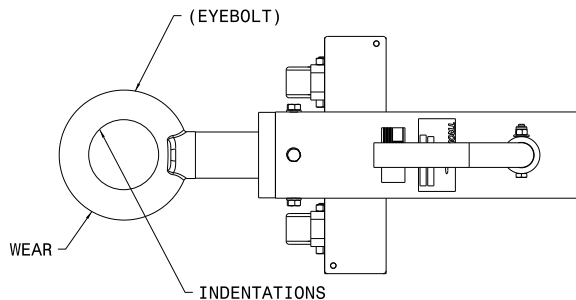

FIGURE 2

4.3.4 Couplers (continued)

Tronair recommends a telecoupler pintle hook arrangement. This arrangement is known to eliminate binding. Tronair offers a Standard Telecoupler, Model Number 01-1950-5000, for use on tugs. **Reference Figure 3.**

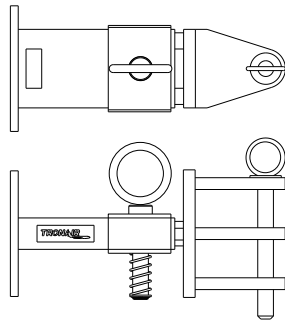

FIGURE 3
01-1950-5000 Standard Telecoupler

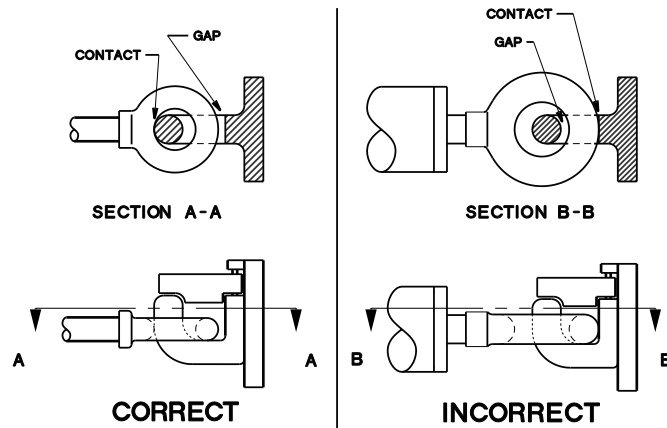

FIGURE 4

Damage to the towbar and/or aircraft can result by towing or pushing an aircraft with an incorrect size eyebolt or pintle pin. A correct size eyebolt will make contact with the pintle pin. A gap between the eyebolt outside diameter and the coupler face plate should be easily seen. An eyebolt which is too large will cause the eyebolt to make contact with the face plate of the coupler. When the eyebolt is too large for the coupler, a gap between the inside diameter of the eyebolt and the coupler face plate will be seen. **Reference Figure 4.**

To ensure proper towing and pushing, check to make sure the pintle pin diameter is not too long for the eyebolt's inside diameter. An approximate one-half inch ($\frac{1}{2}$ ") gap between the pin diameter and the eyebolt should be seen. If any of these conditions are not met, please contact Tronair for information to obtain a new coupler.

4.3.5 Towing Operation

Damage to the towbar or aircraft can result from pushing an aircraft while maintaining too sharp of an angle between the tug and the aircraft. Contact between the towbar weldment and the tug must be avoided. It is recommended that the angle between the tug and towbar not exceed 90°. **Reference Figure 5.**

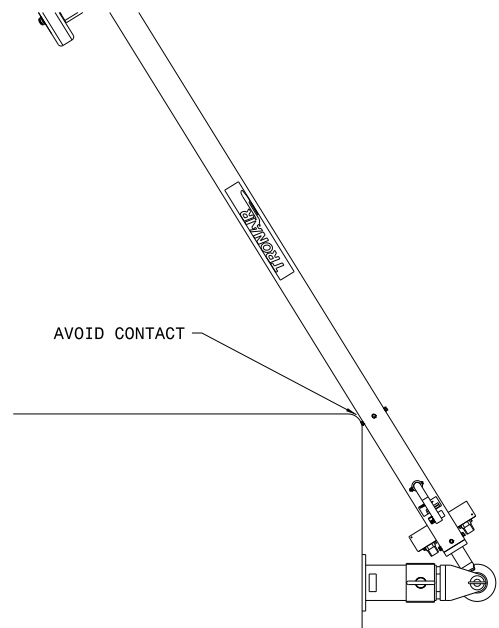

FIGURE 5

5.0 PROVISION OF SPARES

10.1 SOURCE OF SPARE PARTS

Spare parts may be obtained from the manufacturer:

TRONAIR, Inc.

1 Air Cargo Pkwy East
Swanton, Ohio 43558 USA

Telephone: (419) 866-6301 or 800-426-6301

Fax: (419) 867-0634

E-mail: sales@tronair.com

Website: www.tronair.com

For Spare Parts, Operations & Service Manuals or Service Needs:
Scan the QR code or visit Tronair.com/aftermarket



10.2 RECOMMENDED SPARE PARTS LISTS

Reference the following page(s) for Replacement Parts and Kits available.

Recommended Spares to be kept on hand:

K-1112.....Kit, Wheel Replacement (Single)

K-1129.....Kit, Sliding Pin Replacement

K-1308.....Kit, Ball Lok Pin Replacement

K-2304.....Kit, Ball Lok Pin Replacement

6.0 IN-SERVICE SUPPORT

Contact Tronair, Inc. for technical services and information. See Section 1.3 – Manufacturer.

7.0 GUARANTEES/LIMITATION OF LIABILITY

Tronair products are warranted to be free of manufacturing or material defects for a period of one year after shipment to the original customer. This is solely limited to the repair or replacement of defective components. This warranty does not cover the following items:

- a) Parts required for normal maintenance
- b) Parts covered by a component manufacturers warranty
- c) Replacement parts have a 90-day warranty from date of shipment

If you have a problem that may require service, contact Tronair immediately. Do not attempt to repair or disassemble a product without first contacting Tronair, any action may affect warranty coverage. When you contact Tronair be prepared to provide the following information:

- a) Product Model Number
- b) Product Serial Number
- c) Description of the problem

If warranty coverage is approved, either replacement parts will be sent or the product will have to be returned to Tronair for repairs. If the product is to be returned, a Return Material Authorization (RMA) number will be issued for reference purposes on any shipping documents. Failure to obtain a RMA in advance of returning an item will result in a service fee. A decision on the extent of warranty coverage on returned products is reserved pending inspection at Tronair. Any shipments to Tronair must be shipped freight prepaid. Freight costs on shipments to customers will be paid by Tronair on any warranty claims only. Any unauthorized modification of the Tronair products or use of the Tronair products in violation of cautions and warnings in any manual (including updates) or safety bulletins published or delivered by Tronair will immediately void any warranty, express or implied.

The obligations of Tronair expressly stated herein are in lieu of all other warranties or conditions expressed or implied. **Any unauthorized modification of the Tronair products or use of the Tronair products in violations of cautions and warnings in any manual (including updates) or safety bulletins published or delivered by Tronair will immediately void any warranty, express or implied and Tronair disclaims any and all liability for injury (WITHOUT LIMITATION and including DEATH), loss or damage arising from or relating to such misuse.**

This page left blank intentionally.

Parts List

When ordering replacement parts/kits, please specify model, serial number and color of your unit.

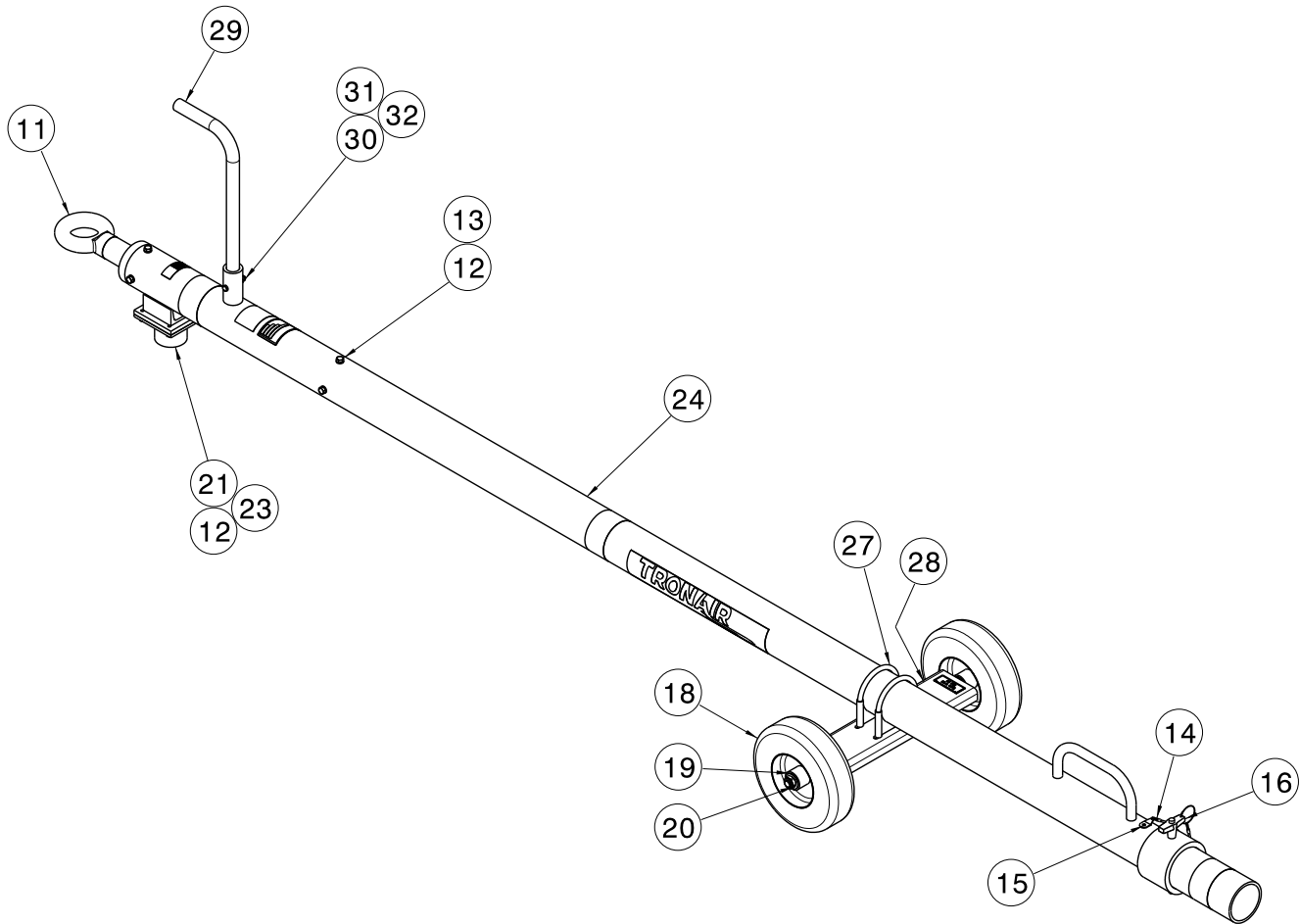

Item	Part Number	Description	Qty
11	Z-1895	Assembly, Shock	1

Item 11 Shock Assembly consists of Items 1 – 10 which are not sold separately. Due to the high compression used in assembly, it is suggested this Shock Assembly returned to Tronair for repair. Discuss with your salesperson.

12	G-1251-1050R	Lockwasher, ¼ Regular	12
13	G-1420-106006	Bolt, Hex Head, Grade 8, 5/16 – 18 x ¾" long	8
18	U-1024	Wheel	2
19	G-1250-1100N	Flatwasher, 5/8 Narrow	1
20	G-1203-1105	Jamnut, 5/8 - 18 Elastic	4
21	Z-5611	Assembly, Skid	2
▶ 23	G-1100-105006	Bolt, Hex Head, Grade 5, ¼ - 20 x ¾" long	4
24	Z-5645-01	Machining, Towbar	1
27	H-1537-07	Clamp, Muffler	2
28	Z-5643-01	Weldment, Axle Mounting	1
29	TR-1857-01	Tube, Handle	1
30	G-1100-105520	Bolt, Hex Head, Grade 5, ¼-28 x 2" long	1
31	G-1202-1055	Stopnut, ¼-28 Elastic	1
32	G-1250-1050N	Flatwasher, ¼ Narrow	1

Parts List

When ordering replacement parts/kits, please specify model, serial number and color of your unit.

Item	Part Number	Description	Qty
	K-1112	Kit, Wheel (Single) Replacement; consists of:	
▶ 18	U-1024	Wheel	1
19	G-1250-1100N	Flatwasher, $\frac{5}{8}$ Narrow	1
20	G-1203-1105	Jamnut, $\frac{5}{8}$ -18 Elastic	1
	◆ K-1460	Kit, Shock Assembly Replacement; consists of:	
11	Z-1895	Assembly, Shock (01-1202-0000)	1
12	G-1251-1060R	Lockwasher, $\frac{5}{16}$ Regular	8
▶ 13	G-1420-106006	Bolt, Hex Head, Grade 8, $\frac{5}{16}$ -18 x $\frac{3}{4}$ " long	8
	K-2304	Kit, Ball Lok Pin Replacement; consists of:	
14	H-1026*12.0	Assembly, Lanyard	1
15	G-1351-04	Rivet, $\frac{1}{8}$ " diameter x $\frac{1}{4}$ " long	1
16	G-1310-0848	Pin, Ball Lok-T, $\frac{1}{2}$ " diameter x 4.8" grip length	1

▶ Use Loctite 271 or equivalent during re-assembly.

◆ Due to the high compression used in assembly, it is suggested this Shock Assembly be returned to Tronair for repair. Discuss with your Salesperson.

Parts List

When ordering replacement parts/kits, please specify model, serial number and color of your unit.

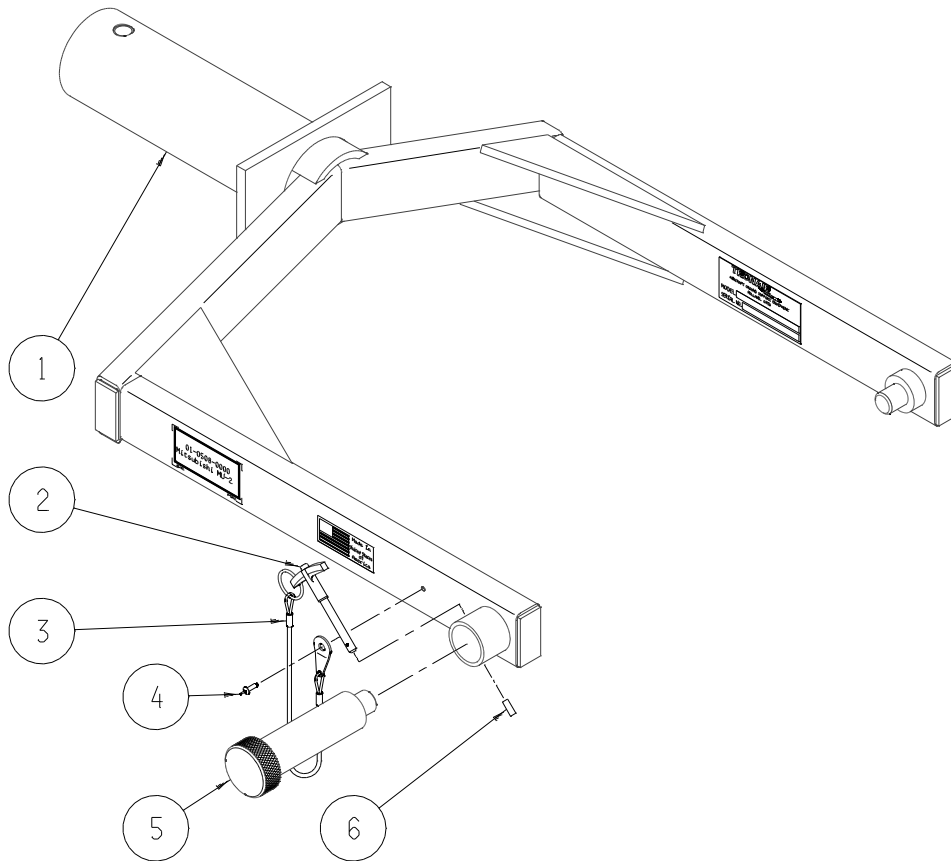

Item	Part Number	Description	Qty
1	Z-4056-01	Head Weldment	<i>Not Sold Separately</i>
	K-1129	Kit, Sliding Pin Replacement; consists of:	
5	B-108	Sliding Pin	1
6	G-1300-19040	Roll Pin, 3/16" diameter x 1/2" long	1
	K-1308	Kit, Ball Lok-T Pin Replacement; consists of:	
2	G-1310-0415	Pin, Ball Lok-T, 1/4" diameter x 1 1/2" long	1
3	H-1026*07.0	Lanyard Assembly	1
4	G-1351-04	Rivet, 1/8 Open-End Steel	1



APPENDIX - I

**Declaration
of
Conformity**



DECLARATION of CONFORMITY

The design, development and manufacture is in accordance with European Community guidelines

Multi-Head Towbar
01-1376-0000

Relevant provisions complied with by the machinery:
2006/42/EC

Relevant standards complied with by the machinery:
EN ISO 12100-1

Identification of person empowered to sign on behalf of the manufacturer:

A handwritten signature in black ink that reads "Patrick Funch". The signature is written in a cursive style and is positioned above a solid horizontal line.

Quality Assurance Representative