

**Models: 01-1269-0020
01A1269-0020
Global Express Custom Towbar**



12/2007 – Rev. 02

**For Spare Parts, Operations & Service Manuals or Service Needs
Scan the QR code or visit Tronair.com/aftermarket**



REVISION
02

DATE
12/2007

TEXT AFFECTED
Added CE marking and Declaration of Conformity, Modified Parts List

TABLE OF CONTENTS

PAGE

1.0	PRODUCT INFORMATION	1
1.1	DESCRIPTION.....	1
1.2	MODEL & SERIAL NUMBER.....	1
1.3	MANUFACTURER.....	1
1.4	SPECIFICATIONS	1
2.0	SAFETY INFORMATION.....	1
2.1	GENERAL.....	1
3.0	TRAINING.....	1
3.1	TRAINING REQUIREMENTS.....	1
3.2	TRAINING PROGRAM	1
3.3	OPERATOR TRAINING.....	1
4.0	OPERATION.....	2
4.1	PRELIMINARY CHECKLIST.....	2
4.1.1	Towbar.....	2
4.1.2	Head Attachment Weldment	2
4.1.3	Sliding Pin.....	2
4.2	USAGE PROCEDURE.....	2
4.2.1	Aircraft Attachment.....	2
4.2.2	Tug Attachment.....	2
4.2.3	Couplers.....	3
4.2.4	Towing Operation.....	3
5.0	PROVISION OF SPARES.....	4
5.1	SPARE PARTS	4
5.2	RECOMMENDED SPARE PARTS LISTS	4
6.0	IN-SERVICE SUPPORT.....	4
7.0	GUARANTEES/LIMITATION OF LIABILITY	4
8.0	APPENDICES	4

Tronair towbars/heads must only be used with matching Tronair heads/towbars, and Tronair shear pins.

This product can not be modified without the written approval of Tronair, Inc. Any modifications done without written approval voids all warranties and releases Tronair, Inc., its suppliers, distributors, employees, or financial institutions from any liability from consequences that may occur. Only Tronair OEM replacement parts shall be used.

1.0 PRODUCT INFORMATION

1.1 DESCRIPTION

The Tronair Model 01-1269-0020 Custom Towbar is designed for towing the Bombardier Global Express BD-700 manufactured by Bombardier Aerospace.

The custom towbar includes pneumatic tires with a urethane skid at the tug end. There is an eyebolt at the towing end of the towbar which incorporates a spring to dampen shock loads. The towing head has machined pins which attach to the aircraft tow point.

1.2 MODEL & SERIAL NUMBER

Reference nameplate on unit

1.3 MANUFACTURER

TRONAIR, Inc.
1 Air Cargo Pkwy East
Swanton, Ohio 43558 USA

Telephone: (419) 866-6301 or 800-426-6301
Fax: (419) 867-0634
E-mail: sales@tronair.com
Website: www.tronair.com

1.4 SPECIFICATIONS

Application.....Global Express BD-700 manufactured by Bombardier Aerospace
Maximum Aircraft Gross Weight.....95,000 lbs (43.1 Metric ton)
Length152.06 in (386.2 cm) From eyebolt centerline to aircraft attachment
Width37.25 in (94.6 cm)
Height.....8.56 in (21.7 cm) From ground to aircraft attachment.
Tube4.5 in (11.43 cm) diameter
Weight173 lbs (78.5 kg)
MaterialAluminum Towbar
Steel Head

2.0 SAFETY INFORMATION

2.1 GENERAL

The Tronair Model 01-1269-0020 and 01A1269-0020 Custom Towbars are used for towing the Bombardier Global Express BD-700 aircraft only.

To ensure safe operation, please read the following statements and understand their meaning. This manual contains safety precautions which are explained as follows. Please read carefully.



WARNING! Warning is used to indicate the presence of a hazard that can cause **severe personal injury, death, and/or substantial property damage** if the Warning Notice is ignored.

CAUTION! Caution is used to indicate the presence of a hazard which will or can cause **minor personal injury or property damage** if the Caution Notice is ignored.

3.0 TRAINING

3.1 TRAINING REQUIREMENTS

The employer of the operator is responsible for providing a training program sufficient for the safe operation of the towbar.

3.2 TRAINING PROGRAM

The employer provided operator training program should cover safety procedures concerning use of the towbar in and around the aircraft at the servicing location.

3.3 OPERATOR TRAINING

The operator training should provide the required training for safe operation of the towbar.

NOTE: Maintenance and Trouble Shooting are to be performed by the skilled and trained technician.

4.0 OPERATION

4.1 PRELIMINARY CHECKLIST

4.1.1 Towbar

- Check towing eye mounting bolts. Ensure the fasteners are not loose or missing.
- Check towing eye for bending, excessive wear and deformity.
- Check the ball lok-T pin. Ensure ball lok-T pin is securely attached to towbar via its lanyard. Ensure ball lok-T pin is not missing.



WARNING!

A damaged or bent towbar should not be used. Towbar should be repaired or replaced.

4.1.2 Head Attachment Weldment

- Check weld between connector tube and head plate for cracks.
- Check weld between head plate and outer shear plates for cracks.
- Check weld between inner shear plate and head rail for cracks.
- Check weld between side rails and head rail for cracks.
- Check weld between side rail and sliding pin sleeve for cracks.
- Check fastener connection of towing head to towbar. Ensure the connection is not loose or missing.
- Check sliding pin roll pin. Ensure roll pin is not loose or missing.
- Check shear pin. Ensure shear pin is not broken; replace if required.
- Check shear plate pivot bolt. Ensure pivot bolt is not missing.

4.1.3 Sliding Pin

- Check sliding pin for bending or excessive wear. Ensure sliding pin slides freely.
- Check sliding pin ball lok-T pin. Ensure ball lok-T pin is securely attached to the head attachment weldment via its lanyard.
- Ensure ball lok-T pin is not loose or missing.

4.2 USAGE PROCEDURE

4.2.1 Aircraft Attachment



CAUTION!

It is recommended that your towbar to attached to the aircraft first, and then connected to the tug to avoid possible aircraft damage.

4.2.2 Tug Attachment



CAUTION!

Damage to the towbar or aircraft can result from an excessive towbar angle during towing operations. Reference Figure 1.

- Use a pintle height so that the towbar is as level as possible during towing. Also, the pintle hook height should prevent contact of the towbar with the ground during towing.

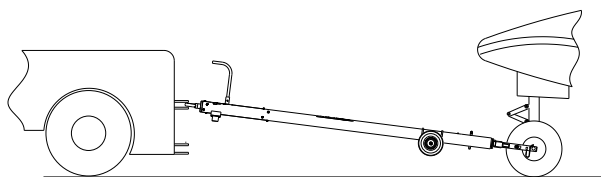

**Incorrect
Excessive Towbar Angle**

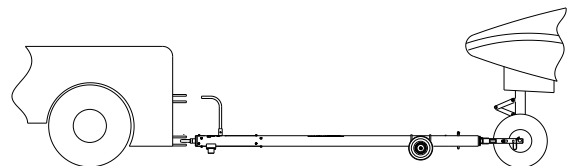

Correct

FIGURE 1

4.2.3 Couplers



CAUTION!

Damage to the towbar or aircraft can result while towing with the following types of couplers:

- Lift Head
- Standard Duty Latch
- Vertical Side Swing Latch
- Swivel Hook

The couplers listed above are known to cause binding and failure in the lunette eye. Indicators of binding are wear on outside diameter of the eyebolt and indentation on the inside diameter of the eyebolt. **Reference Figure 2.**

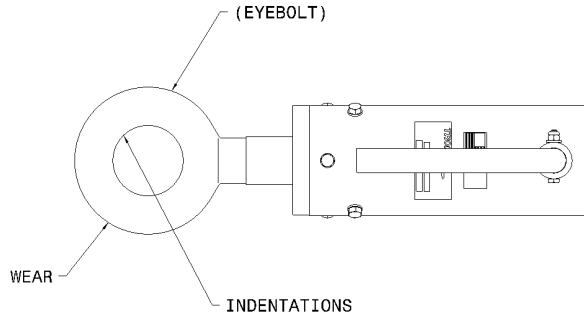

FIGURE 2

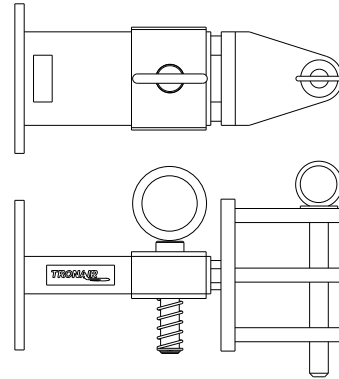

FIGURE 3

01-1950-5000 Standard Telecoupler

Tronair recommends a telecoupler pintle hook arrangement. This arrangement is known to eliminate binding. Tronair offers a Standard Telecoupler, Model Number 01-1950-5000, for use on tugs. **Reference Figure 3.**

Damage to the towbar and/or aircraft can result by towing or pushing an aircraft with an incorrect size eyebolt or pintle pin. A correct size eyebolt will make contact with the pintle pin. A gap between the eyebolt outside diameter and the coupler face plate should be easily seen. An eyebolt which is too large will cause the eyebolt to make contact with the face plate of the coupler. When the eyebolt is too large for the coupler, a gap between the inside diameter of the eyebolt and the coupler face plate will be seen. **Reference Figure 4.**

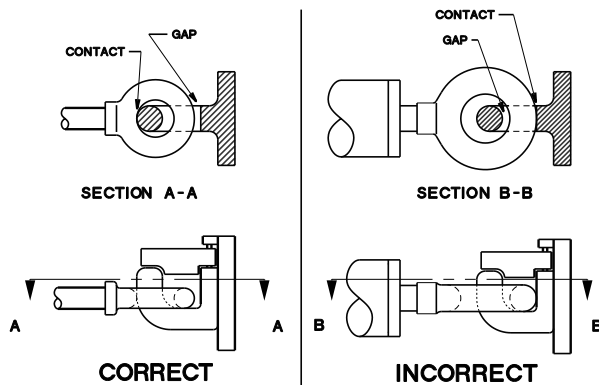

FIGURE 4

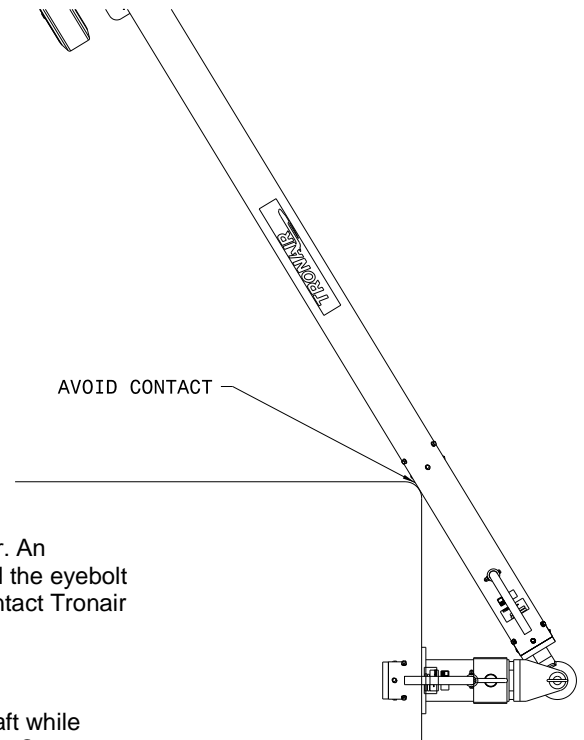

FIGURE 5

To ensure proper towing and pushing, check to make sure the pintle pin diameter is not too long for the eyebolt's inside diameter. An approximate one-half inch (1/2") gap between the pin diameter and the eyebolt should be seen. If any of these conditions are not met, please contact Tronair for information to obtain a new coupler.

4.2.4 Towing Operation

Damage to the towbar or aircraft can result from pushing an aircraft while maintaining too sharp of an angle between the tug and the aircraft. Contact between the towbar weldment and the tug must be avoided. It is recommended that the angle between the tug and towbar not exceed 90°. **Reference Figure 5.**

5.0 PROVISION OF SPARES

5.1 SPARE PARTS

Spare parts may be obtained from the manufacturer:

TRONAIR, Inc.

1 Air Cargo Pkwy East

Swanton, Ohio 43558 USA

Telephone: (419) 866-6301 or 800-426-6301

Fax: (419) 867-0634

E-mail: sales@tronair.com

Website: www.tronair.com

For Spare Parts, Operations & Service Manuals or Service Needs:

Scan the QR code or visit Tronair.com/aftermarket



5.2 RECOMMENDED SPARE PARTS LISTS

Reference the following page(s) for Replacement Parts and Kits available.

K-1550..... KIT, REPL. WHEEL (SINGLE)

K-1736..... KIT, REPL. WHEEL (SINGLE)

6.0 IN-SERVICE SUPPORT

Contact Tronair, Inc. for technical services and information. See Section 1.3 – Manufacturer.

7.0 GUARANTEES/LIMITATION OF LIABILITY

Tronair products are warranted to be free of manufacturing or material defects for a period of one year after shipment to the original customer. This is solely limited to the repair or replacement of defective components. This warranty does not cover the following items:

- a) Parts required for normal maintenance
- b) Parts covered by a component manufacturers warranty
- c) Replacement parts have a 90-day warranty from date of shipment

If you have a problem that may require service, contact Tronair immediately. Do not attempt to repair or disassemble a product without first contacting Tronair, any action may affect warranty coverage. When you contact Tronair be prepared to provide the following information:

- a) Product Model Number
- b) Product Serial Number
- c) Description of the problem

If warranty coverage is approved, either replacement parts will be sent or the product will have to be returned to Tronair for repairs. If the product is to be returned, a Return Material Authorization (RMA) number will be issued for reference purposes on any shipping documents. Failure to obtain a RMA in advance of returning an item will result in a service fee. A decision on the extent of warranty coverage on returned products is reserved pending inspection at Tronair. Any shipments to Tronair must be shipped freight prepaid. Freight costs on shipments to customers will be paid by Tronair on any warranty claims only. Any unauthorized modification of the Tronair products or use of the Tronair products in violation of cautions and warnings in any manual (including updates) or safety bulletins published or delivered by Tronair will immediately void any warranty, express or implied.

The obligations of Tronair expressly stated herein are in lieu of all other warranties or conditions expressed or implied. **Any unauthorized modification of the Tronair products or use of the Tronair products in violations of cautions and warnings in any manual (including updates) or safety bulletins published or delivered by Tronair will immediately void any warranty, express or implied and Tronair disclaims any and all liability for injury (WITHOUT LIMITATION and including DEATH), loss or damage arising from or relating to such misuse.**

8.0 APPENDICES

APPENDIX I Declaration Of Conformity

Parts List

When ordering replacement parts/kits, please specify model, serial number and color of your unit.

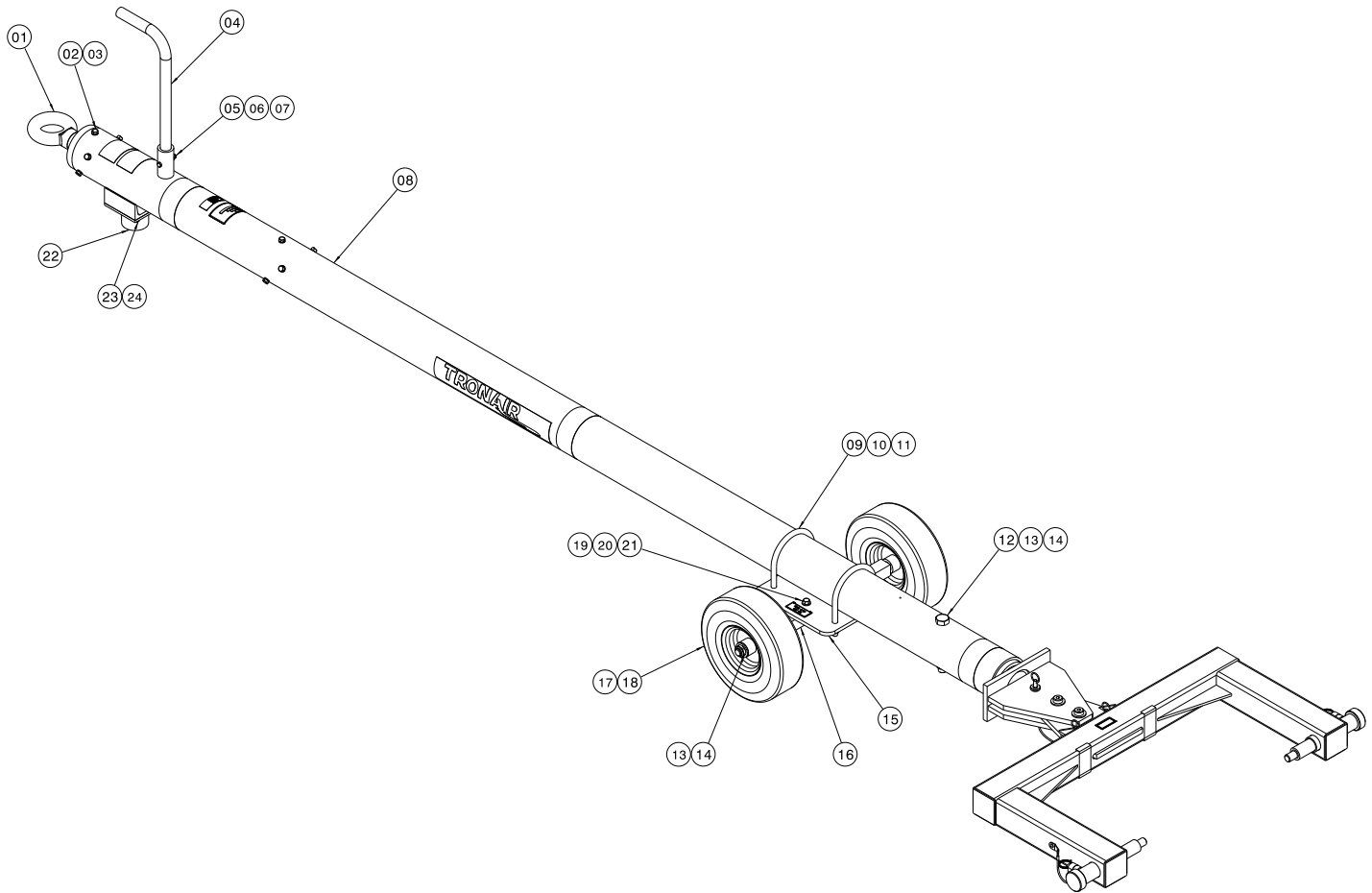

Item	Part Number	Description	Qty
1	Z-4753	Assembly, Shock – 01-1269-0020	1
	Z-4752	Assembly, Shock – 01A1269-0020	

Item 1 consists of items which are not sold separately. Due to the high compression used in assembly, it is suggested this Shock Assembly be returned to Tronair for repair. Discuss with your Salesperson.

2	G-1420-106012	Bolt, Hex Head, Grade 5, $\frac{5}{16}$ -18 x 1 $\frac{1}{4}$ " long	12
3	G-1251-1060R	Lockwasher, $\frac{5}{16}$ " Regular	12
4	TR-1857-01	Tube, Handle	1
5	G-1100-105520	Bolt, Hex Head, Grade 5, $\frac{1}{4}$ -28 x 2" long	1
6	G-1202-1055	Stopnut, $\frac{1}{4}$ -28 Elastic	1
7	G-1250-1050N	Flatwasher, $\frac{1}{4}$ Narrow	1
8	Z-5756-01	Machining, Towbar	1
9	G-1009-38	U-bolt	2
10	G-1250-1090N	Flatwasher, $\frac{1}{2}$ Narrow	4
11	G-1202-1090	Stopnut, $\frac{1}{4}$ -13 Elastic	4
12	G-1420-111554	Bolt, Hex Head, Grade 8, $\frac{3}{4}$ -16 x 5 $\frac{1}{2}$ " long	1
13	G-1250-1110N	Flatwasher, $\frac{3}{4}$ Narrow	3
14	G-1203-1115	Jamnut, $\frac{3}{4}$ -16 Elastic	3
15	J-2599-01-01	Plate, Wheel-Towbar Mounting	1

► Use Loctite 271 or equivalent during re-assembly.

Parts List

When ordering replacement parts/kits, please specify model, serial number and color of your unit.

Item	Part Number	Description	Qty
16	Z-3579-01-01	Weldment, Axle	1
17	U-1027	Wheel, Pneumatic Tire	2
18	TR-1585	Spacer, Wheel	2
19	G-1100-107514	Bolt, Hex Head, Grade 5, 3/8 - 24 x 1 1/2" long	2
20	G-1202-1075	Stopnut, 3/8 - 24 Elastic	2
21	G-1250-1070N	Flatwasher, 3/8 Narrow	4
22	Z-5611	Assembly, Skid	1
23	G-1100-105006	Bolt, Hex Head, Grade 5, 1/4-20 x 3/4" long	4
24	G-1251-1050R	Lockwasher, 1/4 Regular	4
	K-1550	Kit, Replacement Wheel (Single); consists of:	
13	G-1250-1110N	Flatwasher, 3/4 Narrow	1
14	G-1203-1115	Jamnut, 3/4-16 Elastic	1
17	U-1027	Wheel, Pneumatic Tire	1
18	TR-1585	Spacer, Wheel	2
	K-1736	Kit, Replacement Wheel (Single); consists of:	
13	G-1250-1110N	Flatwasher, 3/4 Narrow	1
14	G-1203-1115	Jamnut, 3/4-16 Elastic	1
17	U-1027	Wheel, Pneumatic Tire	1
	K-2663	Kit, Replacement Wheel-Towbar Bracket; consists of:	
9	G-1009-38	U-bolt	2
10	G-1250-1090N	Flatwasher, 1/2 Narrow	4
11	G-1202-1090	Stopnut, 1/4 -13 Elastic	4
15	J-2599-01-01	Plate, Wheel-Towbar Mounting	1
	K-2664	Kit, Replacement Axle; consists of:	
16	Z-3579-01-01	Weldment, Axle	1
18	TR-1585	Spacer, Wheel	2
19	G-1100-107514	Bolt, Hex Head, Grade 5, 3/8 - 24 x 1 1/2" long	2
20	G-1202-1075	Stopnut, 3/8 - 24 Elastic	2
21	G-1250-1070N	Flatwasher, 3/8 Narrow	4
	K-3274	Kit, Replacement Shock Assembly; consists of:	
1	Z-4753	Assembly, Shock	1
2	G-1420-106012	Bolt, Hex Head, Grade 5, 5/16 -18 x 1 1/4" long	12
3	G-1251-1060R	Lockwasher, 5/16" Regular	12
	K-3734	Kit, Replacement Skid; consists of:	
22	Z-5611	Assembly, Skid	1
23	G-1100-105006	Bolt, Hex Head, Grade 5, 1/4-20 x 3/4" long	4
24	G-1251-1050R	Lockwasher, 1/4 Regular	4
	K-3976	Kit, Towbar Tube; consists of:	
8	Z-5756-01	Machining, Towbar	1

► Use Loctite 271 or equivalent during re-assembly.

Parts List

When ordering replacement parts/kits, please specify model, serial number and color of your unit.

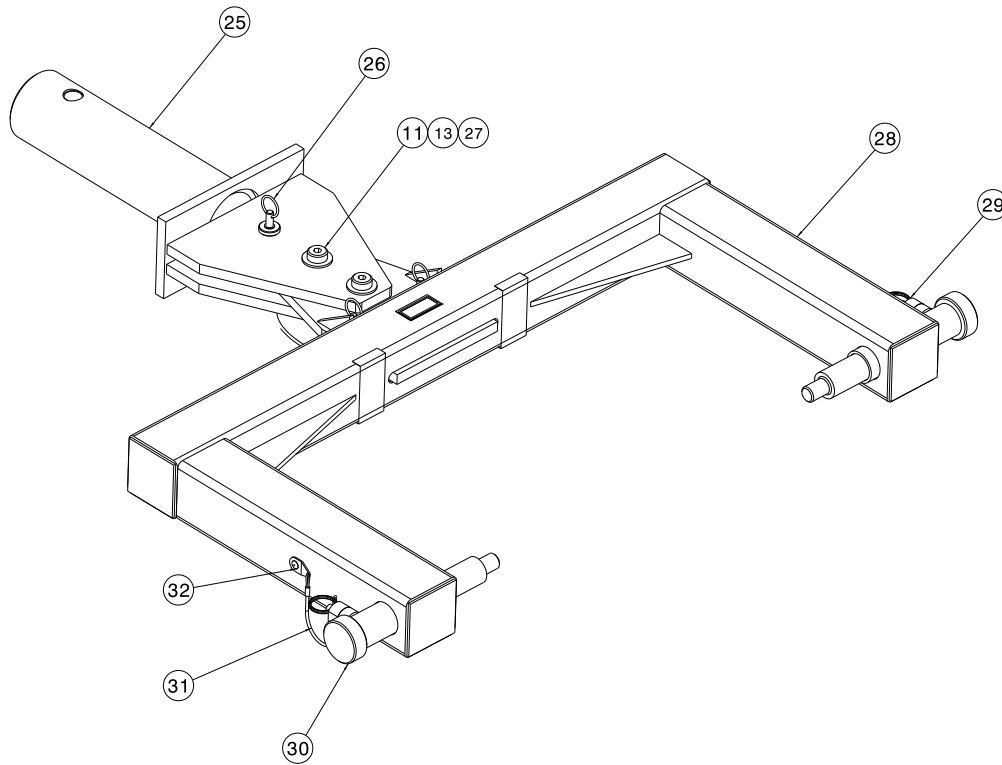

Item	Part Number	Description	Qty
11	G-1202-1090	Stopnut, ¼ -13 Elastic	2
13	G-1250-1110N	Flatwasher, ¾ Narrow	2
25	Z-5659-01	Shear Plate Replacement	1
26	G-1453-22	Pin, Shear	3
27	G-1155-109216	Screw, Socket Head Shoulder, 5/8 " diameter	2
28	Z-4096-01	Weldment, Head	1
29	Z-2626	Assembly, Handle	2
30	R-1855	Pin, Sliding	2
31	H-2443*07.0	Assembly, Lanyard	2
32	G-1351-18	Rivet, 3/16 Open-end Steel	2
	K-1949	Kit, Replacement Pivot Bolt; consists of:	
11	G-1202-1090	Stopnut, ¼ -13 Elastic	2
13	G-1250-1110N	Flatwasher, ¾ Narrow	2
27	G-1155-109216	Screw, Socket Head Shoulder, 5/8 " diameter	2
	K-2657	Kit, Replacement Shear Plate; consists of:	
11	G-1202-1090	Stopnut, ¼ -13 Elastic	2
13	G-1250-1110N	Flatwasher, ¾ Narrow	2
25	Z-5659-01	Shear Plate Replacement	1
27	G-1155-109216	Screw, Socket Head Shoulder, 5/8 " diameter	2
	K-2660	Kit, Replacement Handle; consists of:	
29	Z-2626	Assembly, Handle	2
31	H-2443*07.0	Assembly, Lanyard	2
32	G-1351-18	Rivet, 3/16 Open-end Steel	2



APPENDIX I

Declaration of Conformity



EU Declaration of Conformity

Model Number(s) 01-1269-0020, 01A1269-0020

Product Type/Name: Custom Towbar

Serial Number(s): Enter serial number(s)

Declaration: Tronair has assessed the equipment described above against the Essential Health and Safety Requirements of one or more Directives. Based on this assessment, the equipment described above is deemed to comply with the directive(s) listed below.

This declaration of conformity is issued under the sole responsibility of the manufacturer.

Directives: European Machinery Directive 2006/42/EC

Standards: EN ISO 12100:2011 Safety of machinery – General principles for design – Risk assessment and risk reduction

Markings:



The technical documentation for the machinery is available from:

Mr. Joel Nunn
34 Epirus Road, SW6 7UH, London, UK
Email: jnunn@tronair.com

Location of Issue: Tronair, 1 Air Cargo Parkway East, Swanton, OH 43558

Certificate: EU_DoC_01-1269-0020, 01A1269-0020

Identification of person empowered to sign on behalf of the Manufacturer:

Patrick Finch
Quality Assurance Representative

Enter a date

Date

