

# TRONAIR

## OPERATION & SERVICE MANUAL

MODELS:

02-0517-0132 02-0522-0132 02-0527-0132  
02-7827-0100 02-7828-0100 02-7837-0100

5 TON  
TWO STAGE JACKS

September 1996

Revision: 09

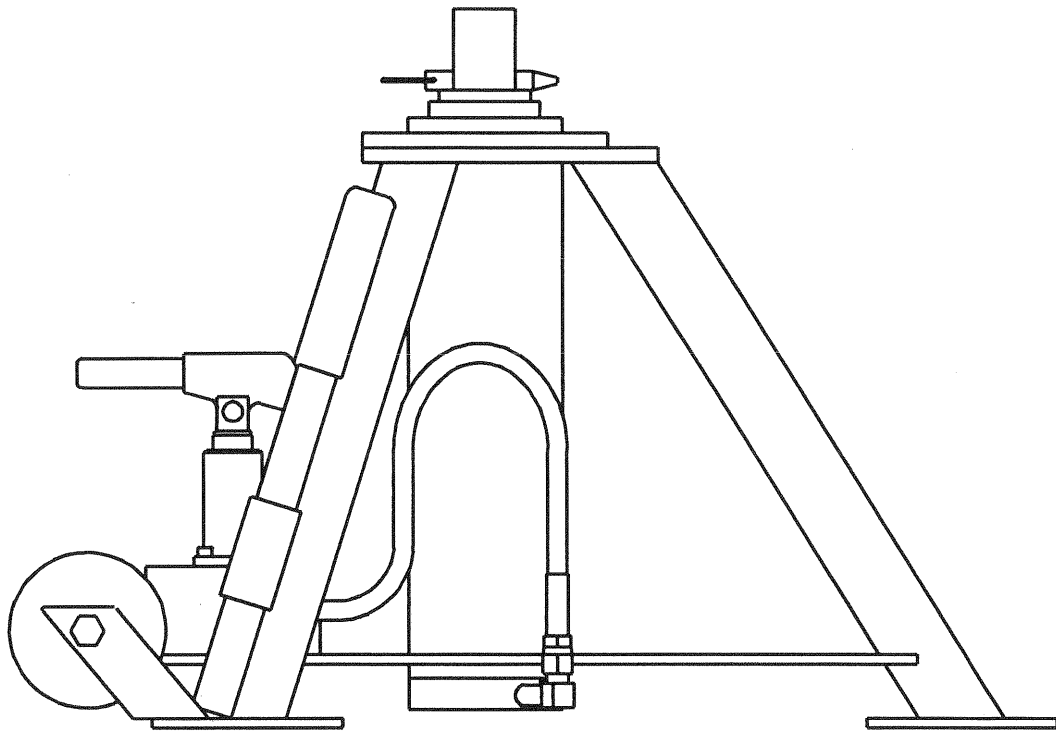

**Tronair**

South 1740 Eber Road  
Holland, Ohio 43528-9794

Phone: (419) 866-6301 • 800-426-6301

Fax: (419) 867-0634

## 5 TON TWO STAGE JACKS

### TABLE OF CONTENTS

	<u>Page</u>
1.0 Description . . . . .	1
2.0 Usage . . . . .	1
3.0 Specifications . . . . .	1
4.0 Assembly Instructions . . . . .	1
4.1 General Information . . . . .	1
4.2 Pre-Use Checks . . . . .	2
5.0 Operating Instructions . . . . .	2
6.0 Maintenance . . . . .	3
6.1 Servicing Jack . . . . .	3
6.2 Removing and Servicing Pump . . . . .	4
6.3 Jack Function Load Test . . . . .	4
7.0 Trouble Shooting . . . . .	5
8.0 Parts List . . . . .	6
Parts List Illustration . . . . .	8

## 5 TON TWO STAGE JACKS

### 1.0 DESCRIPTION

The Tronair Two Stage Jack incorporates the following quality features:

- Two-stage telescoping rams
- Steel Construction
- Mechanical ram lock nut that prevents lowering of jack under load
- Quick action mechanical extension
- Single speed, manually operated pump with pressure relief
- Uses standard MIL-H-5606 hydraulic fluid
- K-2017 jack pad kit available with the 02-0517-0132 for the ATR-42.

### 2.0 USAGE

The purpose of the following jacks are to lift the aircraft for maintenance. See specifications for capacity of each jack.

### 3.0 SPECIFICATIONS

Model	Capacity (lbs)	Closed Height	Mechanical Extension	Hydraulic Extension	Fully Extended	Weight (lbs)
02-0517	10,000	17"	7"	25"	49"	105
02-0522	10,000	22"	7"	25"	54"	108
02-0527	10,000	27"	9"	38"	74"	130
02-7827	10,000	32"	9"	38"	79"	135
02-7828	10,000	21"	7"	29"	57"	108
02-7837	10,000	38"	9"	38"	85"	190

### 4.0 ASSEMBLY INSTRUCTIONS

#### 4.1 GENERAL INFORMATION

This product should be assembled and/or repaired using good workmanship practices and proper tools. Bolts and elastic stopnuts should be tightened to a torque not to exceed industry standards for grade '5' bolts.  $\frac{3}{8}$ -24 bolts should be tightened to 35 ft. lbs.

All replacement parts must be the same as or equal to the original parts supplied.

## 5 TON TWO STAGE JACKS

### 4.2 PRE-USE CHECKS

Refer to the Illustrated Parts Breakdown to identify and assure that all parts are present.

- Generally check over unit to assure the tightness of all nuts, bolts and fittings.
- With rams completely collapsed, check hydraulic fluid level: correct level is 1.5 inches below vent, with the hydraulic ram fully retracted. Replenish with MIL-H-5606 fluid as required.

### 5.0 OPERATING INSTRUCTIONS

The user should be familiar with the following statements prior to using the jack(s).

#### CAUTION:

1. Never put hands between aircraft and jack pad. Aircraft struts may hang up and allow aircraft to suddenly drop.
2. Never align jack under aircraft by pounding on jack legs. Dented legs may lead to jack collapse.
3. Always lower ram locking nut(s) as aircraft is raised. Be sure ram nut(s) is seated fully after jacking.
4. Always raise and lower jacks simultaneously so that aircraft remains level.
5. Always use a tail or nose stand for additional stability.

### JACK INSTRUCTIONS

#### TO RAISE AIRCRAFT:

1. Place jack on a hard level surface.
2. Raise mechanical extension as close to aircraft jack pad as possible.
3. Close pump release valve and operate pump.
4. Lower ram locknuts as aircraft is raised.

#### TO LOWER AIRCRAFT:

1. Lower all jacks simultaneously.
2. If ram locking nut(s) is tight, raise jack slightly to release nut(s).
3. Loosen pump release valve slightly to slowly lower aircraft. Raise locking nut(s), as jack ram(s) lower.

## 5 TON TWO STAGE JACKS

### 5.0 OPERATING INSTRUCTIONS (Continued)

When using the jack during a washing or cleaning operation, the jack should be completely covered to protect it from cleaning solution, dirt and foreign matter that might get on or between the ram and cylinder causing damage to the seals and o-rings.

### 6.0 MAINTENANCE

#### GENERAL

- The jack should be stored with some type of cover to protect the jack from liquids (such as Skydrol or cleaning solutions) and other foreign matter that might get on or between ram and cylinder which will damage seals and o-rings.
- All maintenance and/or repair work should be done using good workmanship practices and proper tools. The work area should be clean and free of dirt.
- When o-rings and backup rings are removed, every effort should be made to avoid the contact of tools with the critical surfaces of parts. Surface deformities could cause degradation of seals and failure.
- It is good practice to replace both o-rings and backup rings once removed. Cut and damaged rings normally result in fluid leakage.
- If either cylinder bore and/or first stage ram bore is found to be rusty, they may be honed; the cylinder to a maximum diameter of 3.029" and the first stage ram to a maximum diameter of 2.383". Surface finish of both bores to be 16 micro inches. If pitting in the bores cannot be removed by this process, the jack cylinder and/or first stage ram must be replaced before the jack can be returned to service.
- At this time flush old hydraulic fluid and dirt from overall system and replenish with new, clean hydraulic fluid.

### 6.1 SERVICING JACK

#### 90-DAY ROUTINE MAINTENANCE

If jack has not been used on a regular basis, then every 90 days the jack should be fully extended and retracted to exercise the seals and to prevent rust build up on the cylinder I.D. While ram is extended, clean the threads and spray with DoALL RPM, LPS or equivalent that is water repellent and will not harm buna "N" o-rings.

## 5 TON TWO STAGE JACKS

### 6.1 SERVICING JACK (Continued)

#### TO DIS-ASSEMBLE JACK FOR SEAL REPLACEMENT

1. Raise first stage ram high enough to allow removal of the retaining snap ring.
2. Raise both first and second stage rams together to the point where this assembly can be lifted from the jack cylinder.

**NOTE:** If the second stage ram is allowed to precede the first stage ram, it will fill with oil causing an oil spill when the assembly is removed from the cylinder.

#### TO RE-ASSEMBLE JACK

1. Re-assemble in reverse order of above.
2. Spray I.D. of cylinder and O.D. of rams (item 10 & 11) with DoALL RPM, LPS or equivalent water repellent that will not harm the buna "N" o-rings to protect surfaces from rusting when not in use.

**NOTE:** To minimize air entrapment under the rams, raise the oil level in the cylinder to chamfer of the cylinder prior to ram insertion.

3. Lightly peen first thread on second stage ram to prevent nut removal after seal kit installation.

### 6.2 REMOVING AND SERVICING PUMP

**NOTE:** If pump is found faulty, call the factory for replacement or replace seals as follows:

1. Review Illustrated parts breakdown - Pump.
2. Clamp suction (push on) hose and remove hose from pump.
3. Uncouple output hose from pump.
4. Remove two (2) pump mounting bolts (item 31). Remove pump.
5. Remove cotter pin (Item 32) from clevis pin.
6. Remove four (4) socket head cap screws.
7. Remove flanges.
8. Remove tube assembly (Item 4).
9. Replace o-rings and back-up ring. (See pump parts list for kits available).
10. Re-assemble in reverse order.

### 6.3 JACK FUNCTION LOAD TEST

If function load testing of this jack is required:

1. Take all necessary precautions to prevent injury.
2. Always jack against a load and never against the jack itself.
3. Do not exceed a test load equal to the jack rated capacity plus 10%.

## 5 TON TWO STAGE JACKS

### 7.0 TROUBLE SHOOTING

<b>TROUBLE</b>	<b>PROBABLE CAUSE</b>	<b>REMEDY</b>
Ram will not rise or rises erratically	High pressure leaks (at joint, plugs or tubing)	Re-tighten or repair
	Leaky discharge check valve	Pump rapidly to dislodge or repair pump
	Leaky ram o-ring packing	Replace packing
	Leaky release valve	Tighten release valve
	Leaky pump o-ring packing	Repair pump
	Lack of oil	Refill reservoir check system for leaks
	Sticking inlet check valve	Pump rapidly to dislodge or repair pump
	Closed air vent	Open
	Air in hydraulic system	Bleed system
Jack will not lower	Ram lock nut not loosened	Rotate nut as ram is lowered
	Broken pump release valve	Repair pump
	Bent ram	Replace suspected ram assembly

## 5 TON TWO STAGE JACKS

### MODEL #

### REPLACEMENT PARTS

0	0	0	7	7	7	Item Number	Part Number	Component Description	Qty
5	5	5	8	8	8	1	G-1307-0825	½ x 2.5 Model "C" Pin	1
1	2	2	2	2	3	2	R-1013-02	Extension	1
7	2	7	7	8	7		R-1013-03		
*	*	*	*	*	*	3	TR-1310	First Stage Locknut	1
*	*	*	*	*	*	4	TR-1159	Guide Ring	1
*	*	*	*	*	*	7	TR-1026	Ram Protection Ring	1
*	*	*	*	*	*	8	TR-1311	Second Stage Locknut	1
*	*	*	*	*	*	9	G-1390	Snap Ring	1
*	*					10	Z-2229-01	Second Stage Ram	1
		*	*		*		Z-2229-02		
				*			Z-2229-03		
*	*					11	Z-2230-01	First Stage Ram Assembly	1
		*	*		*		Z-2230-02		
				*			Z-2230-03		
*	*					14	Z-1558-01-01	Tube Weldment	1
		*	*		*		Z-1558-02-01		
				*			Z-1558-03-01		
*	*	*	*	*	*	16	N-2410-01	90° Male Elbow	2
*	*	*	*	*	*	17	TF-1047-01*12.0	Push-on Hose (¼)	1
*	*	*	*	*	*	19	G-1100-109526	½-20 x 2-¾ lg H. H. Bolt	2
*	*	*	*	*	*	20	G-1203-1095	½-20 Elastic Jamnut	2
*	*	*	*	*	*	21	H-1045	Breather	1
*	*	*	*	*	*	23	G-1250-1050	¼ Flatwasher	3
*	*	*	*	*	*	24	G-1202-1050	¼-20 Elastic Jamnut	3
*	*	*	*	*	*	25	G-1154-107210	⅜-16 x 1 lg SBCS	3
*	*	*	*	*	*	26	TF-1043-03*21.0	Hose Assembly	1
*						28	H-1009-02	Handle Assembly	1
	*	*	*	*	*		H-1009-04		
*	*	*	*	*	*	29	N-2005-10-S	Male Elbow	1
*	*	*	*	*	*	30	G-1100-107010	⅜-16 x 1 lg H. H. Bolt	2
*	*	*	*	*	*	31	G-1251-1070R	⅜ Regular Lockwasher	2





## 5 TON TWO STAGE JACKS

### REPLACEMENT KITS

0	0	0	7	7	7	Kit Number	Component Description	Qty	
5	5	5	8	8	8	K-2037	Jack Weldment, Replacement Kit; consists of: - Item 15 Jack Weldment w/ labels	1	
1	2	2	2	2	3				
7	2	7	7	8	7				
*									K-1333
	*								K-1330
		*							K-2329
				*		K-2409			
			*			K-2649			
		*	*		*	K-1061-02	Reservoir Replacement Kit; consists of: - Item 16 Male Elbow - Item 17 Push-On Hose (1/4) - Item 21 Breather	1 1 1	
*	*			*					K-1061-04
*	*	*	*	*	*	K-1035	Seal Replacement Kit; consists of: - Item 4 Guide Ring - Item 5 O-Ring (2-329) - Item 6 Backup (8-329) - Item 12 O-Ring (2-334) - Item 13 Backup (8-334)	1 1 1 1 1	
*	*	*	*	*	*				
*	*	*	*	*	*				
*	*	*	*	*	*				
*	*	*	*	*	*				
*	*	*	*	*	*	K-1987	Pump Replacement Kit; consists of: - Item 16 Male Elbow - Item 17 Push-on Hose (1/4) - Item 27 Hand Pump - Item 29 Male Elbow - Item 30 3/8-16 x 1 lg H H Bolt - Item 31 3/8 Regular Lockwasher	1 1 1 1 2 2	
*	*	*	*	*	*				
*	*	*	*	*	*				
*	*	*	*	*	*				
*	*	*	*	*	*				
*	*	*	*	*	*				
*	*	*	*	*	*	K-1165	Wheel Replacement Kit; consists of: - Item 18 Wheel - Item 19 1/2-20 x 2-3/4 lg H. H. Bolt - Item 20 1/2-20 Elastic Jamnut	2 2 2	
*	*	*	*	*	*				
*	*	*	*	*	*				
*	N	N		N		K-2017	Jack Pad Replacement Kit (ATR 42)	1	
	/	/		/					
	A	A		A					

## 5 TON TWO STAGE JACKS

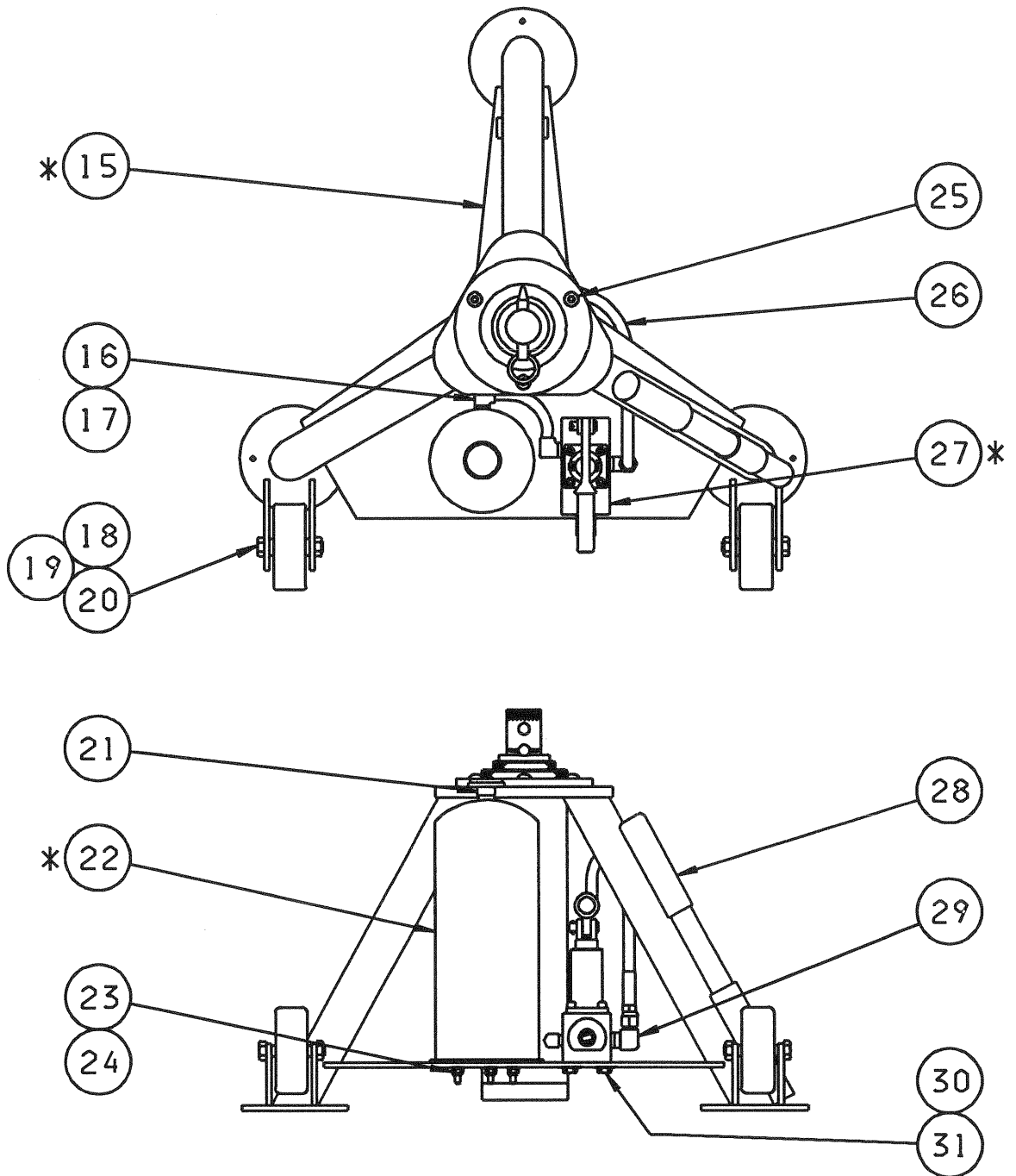

\* Item included in Replacement Kit

## 5 TON TWO STAGE JACKS

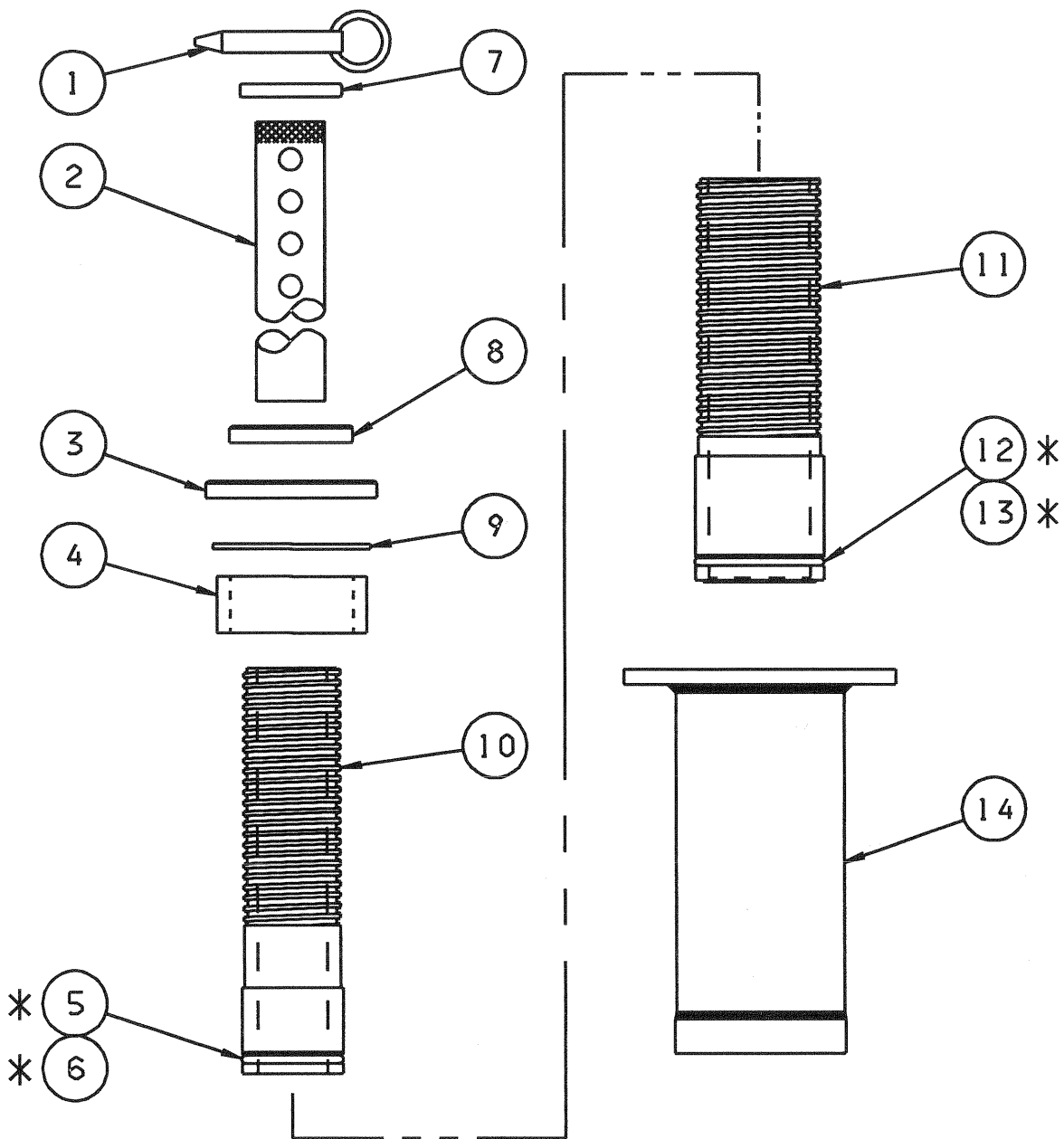

\* Item included in Replacement Kit