

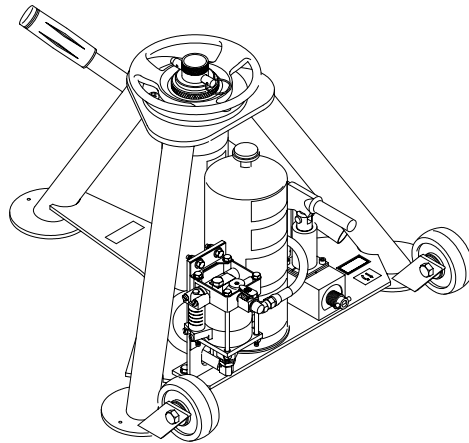

Operation & Service Manual



Models:

02-0522-0140

02A0522-0140 (with Air Pump)

5 Ton (4.5 Metric Ton)

Two Stage Jack

11/2004 - AA - Rev. 04

Includes Illustrated Parts Lists

Tronair, Inc.

1740 Eber Road
Holland, Ohio 43528-9794
USA

Telephone: (419) 866-6301 • 800-426-6301

Fax: (419) 867-0634

Web Site: www.tronair.com E-mail: mail@tronair.com

Models: 02-0522-0140 & 02A0522-0140
5 Ton (4.5 Metric Ton)
Two Stage Jack

TABLE OF CONTENTS

PAGE

1.0	Product Information.....	1
1.1	Usage.....	1
1.2	List Of Drawings.....	1
2.0	Safety Information.....	1
2.1	Alarm And Warning Systems.....	1
2.2	Warning And Danger Signs.....	1
2.3	Component Safety Features.....	1
2.4	Functional Safety Features.....	1
2.5	Features For Operator Safety.....	1
2.6	Environmental Safety Features.....	1
2.7	Protection Systems.....	2
2.8	Closed Circuits.....	2
2.9	Interlocking.....	2
2.10	Necessary Personal Protective Equipment.....	2
2.11	Safety Guidelines.....	2
2.12	Conditions For Safe Use.....	2
2.13	Operator Qualifications.....	2
2.14	Additional Safety Measures.....	2
3.0	Packaging And Storage.....	3
3.1	Packaging Requirements.....	3
3.2	Handling.....	3
3.3	Strapping.....	3
3.4	Packaging Protection.....	3
3.5	Labeling Of Packaging.....	3
3.6	Storage Compatibility.....	3
3.7	Storage Environment.....	3
3.8	Storage Space And Handling Facilities.....	3
4.0	Transportation.....	3
5.0	Assembly.....	3
5.1	General Instructions.....	3
5.2	Pre-Use Checks.....	4
5.3	Personnel Requirements.....	4
5.4	Inspection And Test Procedures.....	4
6.0	Installation.....	4
6.1	Air Supply Requirements.....	4
7.0	Operation.....	4
7.1	Operating Parameters.....	4
7.2	Numerical Values.....	4
7.3	Operator Controls.....	5
7.4	Operating Instructions.....	5
	7.4.1 Rules For Operating.....	5
	7.4.2 Jack Instructions.....	5
8.0	Training.....	7
9.0	Maintenance.....	8
9.1	General.....	8
9.2	Maintenance Schedule.....	8
	9.2.1 Storage/Low Usage.....	8
9.3	Servicing Jack.....	8
9.4	Removing And Servicing Pump.....	9
9.5	Jack Function Load Test.....	9
9.6	Pneumatic Pump.....	9
10.0	Trouble Shooting.....	9
11.0	Provision Of Spares.....	10
12.0	Parts List.....	10
13.0	In-Service Support.....	10

Models: 02-0522-0140 & 02A0522-0140
5 Ton (4.5 Metric Ton)
Two Stage Jack

14.0 Guarantees 10
15.0 Appendices 11

Models: 02-0522-0140 & 02A0522-0140
5 Ton (4.5 Metric Ton)
Two Stage Jack

REVISION
04

DATE
11/2004

TEXT AFFECTED
pg 6 7.4.2 added warning and illustrations

**Models: 02-0522-0140 & 02A0522-0140
5 Ton (4.5 Metric Ton)
Two Stage Jack**

This product can not be modified without the written approval of Tronair, Inc. Any modifications done without written approval voids all warranties and releases Tronair, Inc., its suppliers, distributors, employees, or financial institutions from any liability from consequences that may occur.

1.0 PRODUCT INFORMATION

Name of Equipment: 5 Ton Two Stage Jack

Model Numbers: 02-0522-0140 or 02A0522-0140. See Nameplate for Serial Number.

Manufactured by: TRONAIR, INC, 1740 Eber Rd., Holland, OH 43528-9794 USA

1.1 USAGE

The device is intended to lift an aircraft by its fuselage and/or main wing with other hydraulic jacks arranged by position and quantity to provide proper balance, and in conjunction with the correct jack pad, whose maximum load on any one jack does not exceed the rated capacity of the jack.

The jacks are not intended for metal forming, metal working, or any purpose other than that stated above.

1.2 LIST OF DRAWINGS

Reference Parts List and Illustrations, Pages 12 to 16.

2.0 SAFETY INFORMATION

2.1 ALARM AND WARNING SYSTEMS

None.

2.2 WARNING AND DANGER SIGNS

See labels on unit.



WARNING!

The ram locknuts are user operated safety devices. Failure to utilize these locknuts may result in personal injury or death.

2.3 COMPONENT SAFETY FEATURES

Ram Locknut prevents lowering of the ram. The Ram Locknut must be lowered as the aircraft is being lifted.

2.4 FUNCTIONAL SAFETY FEATURES

Pressure Relief Valve prevents overload during raising operations.

2.5 FEATURES FOR OPERATOR SAFETY

Cautions and Instruction Labels located on jack Ram Locknut

2.6 ENVIRONMENTAL SAFETY FEATURES

The jack is non-polluting. See Appendix for Material Safety Data concerning the recommended hydraulic fluid (MIL-H-5606).

2.0 Safety Information continued on following page.

TRONAIR

11/2004 - AA - Rev. 04

- 1 -

Models: 02-0522-0140 & 02A0522-0140
5 Ton (4.5 Metric Ton)
Two Stage Jack

2.0 SAFETY INFORMATION *(continued)*

2.7 PROTECTION SYSTEMS

None.

2.8 CLOSED CIRCUITS

None.

2.9 INTERLOCKING

None.

2.10 NECESSARY PERSONAL PROTECTIVE EQUIPMENT



CAUTION!

Always wear safety glasses.

2.11 SAFETY GUIDELINES



CAUTION!

Do not place hands on top of jack near ram locknuts while lowering jack.

Pinch points exist between top of jack and threads on ram.

1. **NEVER** put hands between the aircraft and the jack pad; as after aircraft has been lowered, struts may have hung up.
2. **NEVER** align jack under aircraft by pounding on jack legs. Dented legs may lead to jack collapse.
3. **ALWAYS** lower ram locking nut(s) after jack is under load. Be sure ram nut(s) is seated fully after jacking.
4. **ALWAYS** raise and lower jacks simultaneously so that aircraft remains level.
5. **ALWAYS** use a tail or nose stand, as applicable, for additional stability.



WARNING!

The ram locknuts are user operated safety devices. Failure to utilize these locknuts may result in personal injury or death.

2.12 CONDITIONS FOR SAFE USE

- Use in a clean dry environment on a level surface.
- Operate between -20° C and 50°C (-4° F and 122° F).

2.13 OPERATOR QUALIFICATIONS

This jack is intended to be used by the skilled and trained aircraft technician. The operator must be familiar with the jacking procedures for the aircraft to be raised, and the operation of the jack.

Installation/Maintenance/Dismantling Qualifications: This jack is to be installed, maintained, and dismantled by qualified technicians familiar with hydraulic systems.

2.14 ADDITIONAL SAFETY MEASURES

This jack must be used in accordance with this technical manual, and in accordance with the aircraft manufacturer's jacking procedures.

Models: 02-0522-0140 & 02A0522-0140
5 Ton (4.5 Metric Ton)
Two Stage Jack

3.0 PACKAGING AND STORAGE

3.1 PACKAGING REQUIREMENTS

Jacks are to be packaged as required to prevent damage to legs or hydraulic equipment during shipment.

3.2 HANDLING

Jacks can be rolled by hand on its casters.

3.3 STRAPPING

Jacks can be strapped down by suitable means to prevent unwanted movement during shipment.

3.4 PACKAGING PROTECTION

No special packaging material for cushioning or suspension is required.

3.5 LABELING OF PACKAGING

Packaging should be labeled **DO NOT DROP**.

3.6 STORAGE COMPATIBILITY

No special considerations.

3.7 STORAGE ENVIRONMENT

- Store jacks between -20°C and +50°C/-4° F and 122° F.
- Always store jack with ram all the way down.
- Suitable for outdoor storage by using a full coverage waterproof tarp or canvas.

3.8 STORAGE SPACE AND HANDLING FACILITIES

- Minimum Closed Height: 22 5/8 in (57.47 cm)
- Mechanical Extension: 7 in (17.78 cm)
- Hydraulic Extension: 22 in (55.88 cm)
- Maximum Height Obtainable: 51 5/8 in (131.13 cm)
- Weight: 108 lbs (48.99 kg)

4.0 TRANSPORTATION

- 4.1 Lifting can be accomplished by crane and strap thru top of tripod, or by fork truck under lower tripod support. Approximate weight is 108 lbs (48.99 kg).

5.0 ASSEMBLY

This product is shipped completely assembled and tested and requires no further assembly before operation. The following sections apply when servicing the unit.

5.1 GENERAL INSTRUCTIONS

1. This product should be assembled and/or repaired using good workmanship practices and proper tools. Bolts and elastic stopnuts should be tightened to a torque not to exceed industry standards for Grade '5' bolts.
2. All replacement parts must be the same as or better than the original parts supplied.
3. Dispose of waste per federal and local laws and regulations.
4. No modifications are allowed that will adversely affect the jacks safety performance.
5. The pressure relief valve is not serviceable. It must be replaced as a unit.

5.0 Assembly continued on following page

TRONAIR

11/2004 - AA - Rev. 04

Models: 02-0522-0140 & 02A0522-0140
5 Ton (4.5 Metric Ton)
Two Stage Jack

5.0 ASSEMBLY *(continued)*

5.2 PRE-USE CHECKS

1. Refer to the Illustrated Parts List to identify and ensure that all parts are present.
2. Generally check over unit to assure the tightness of all nuts, bolts and fittings.
3. With rams completely collapsed, check hydraulic fluid level.
 - Replenish with MIL-H-5606 fluid as required.
 - **Fluid Level:** 1.5 inches (3.8 cm) below vent.

NOTE: *Refer to fluid manufacturer's (Appendix) Material Safety Data Sheet, and advisory for handling and disposal of fluid.*

5.3 PERSONNEL REQUIREMENTS

This jack is to be assembled by qualified technicians familiar with hydraulic systems.

5.4 INSPECTION AND TEST PROCEDURES

1. Ensure fluid level is within 1.5 inches (3.8 cm) from reservoir vent cap.
2. Raise ram to full stroke, and check for leaks.

6.0 INSTALLATION

Installation and commissioning requires connection of the air valve to an adequate air supply (*Air Pump equipped Models only*).

6.1 AIR SUPPLY REQUIREMENTS

- 25 psi (1.72 bar) Minimum
- 40 psi (2.75 bar) Recommended
- 125 psi (8.60 bar) Maximum

7.0 OPERATION

7.1 OPERATING PARAMETERS

1. The user shall work in accordance with the Operator Manual.
2. At no time shall personnel work under the raised load until it is secured by suitable means, *i.e. ram locknut*.
3. The employer of the operator shall provide for all necessary training and give information about pumping and translating forces.
4. Operate between -20° C and 50°C (-4° F and 122° F).

7.2 NUMERICAL VALUES

- Rated Capacity: 10,000 lbs (4,536 kg)
- Minimum Closed Height: 22 5/8 in (54.47 cm)
- Mechanical Extension: 7 in (17.78 cm)
- Hydraulic Extension: 22 in (55.88 cm)
- Maximum Height Obtainable: 51 5/8 in (131.13 cm)
- Weight: 108 lbs (48.99 kg)
- Pressure Relief Setting: 2,500 +250/-0 psig (172.4+17.2/-0 bar)
- Noise level is 64 dB(A) at a distance of 120 in (304.8 cm) at an inlet pressure of 100 psi (6.9 bar)

Models: 02-0522-0140 & 02A0522-0140
5 Ton (4.5 Metric Ton)
Two Stage Jack

7.0 OPERATION

7.3 OPERATOR CONTROLS

See **Figure 7.3**

7.4 OPERATING INSTRUCTIONS

The user should be familiar with the following statements prior to using the jack(s):



CAUTION!

1. **NEVER** put hands between the aircraft and the jack pad; as after aircraft has been lowered, struts may have hung up.
2. **NEVER** align jack under aircraft by pounding on jack legs. Dented legs may lead to jack collapse.
3. **ALWAYS** lower ram locking nut(s) after jack is under load. Be sure ram nut(s) is seated fully after jacking.
4. **ALWAYS** raise and lower jacks simultaneously so that aircraft remains level.
5. **ALWAYS** use a tail or nose stand, as applicable, for additional stability.

7.4.1 Rules For Operating

1. The user shall work in accordance with the Operator and/or Technical Manuals.
2. At no time shall personnel work under the raised load until it is secured by suitable means, i.e. ram locknut.
3. The employer of the operator shall provide for all necessary training and give information about pumping and translating forces.
4. Operate between -20° C and 50°C/-4° F and 122° F.

7.4.2 Jack Instructions

To Raise Aircraft:

1. Place jack on a hard, level surface.
2. Raise mechanical extension as close to aircraft jack pad as possible.

7.4.2 Jack instructions continued on following page.

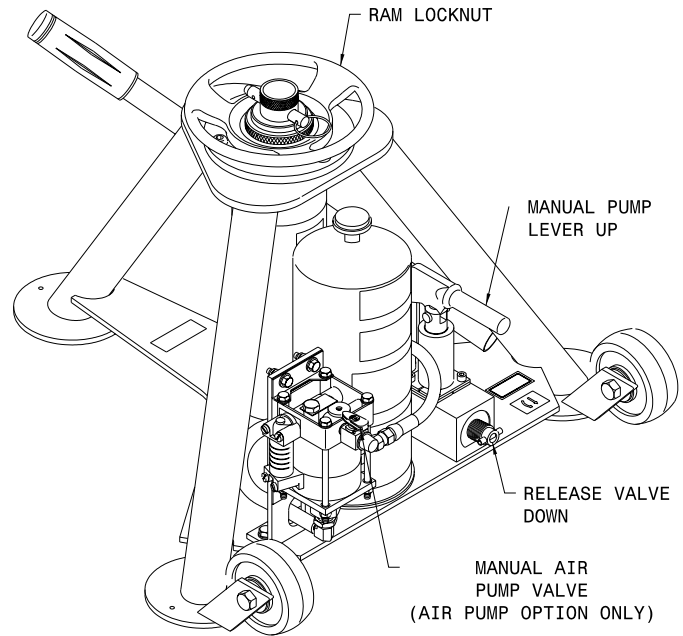

FIGURE 7.3 – Operator Controls

Models: 02-0522-0140 & 02A0522-0140
5 Ton (4.5 Metric Ton)
Two Stage Jack

7.4.2 Jack Instructions (continued)



WARNING!

The locking pin **MUST** be placed in the ram protection ring groove and fully through the mechanical extension.

The ball lock **MUST** be placed outside the ram protection ring.

- Do not place extra locking pins in any other hole on the mechanical extension.
- Insure mating surfaces to jack point are free of debris and damage.
- Under no conditions should the locking pin's ball lock be inside the ram protection ring groove.
- Never use the jack if the ram protection ring is not installed.
- Never use a locking pin that has been damaged.
- Never use a ram protection ring that has been damaged or deformed.
- Failure to comply could result in premature failure below certified weight and could cause serious injury including death.

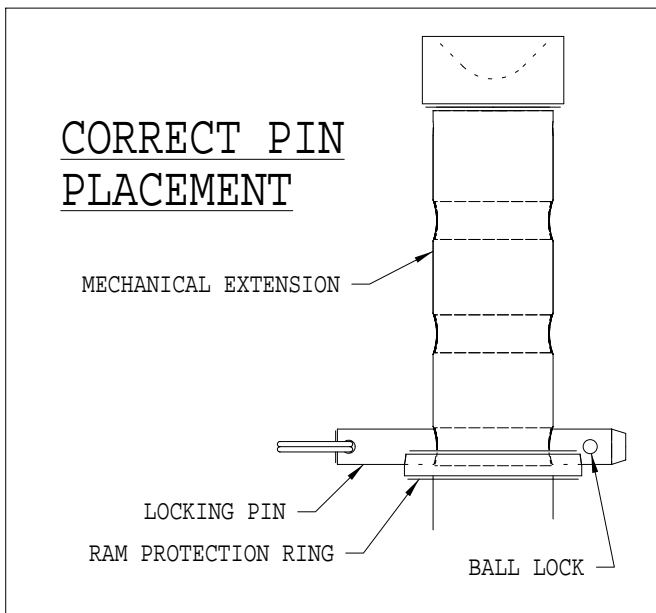
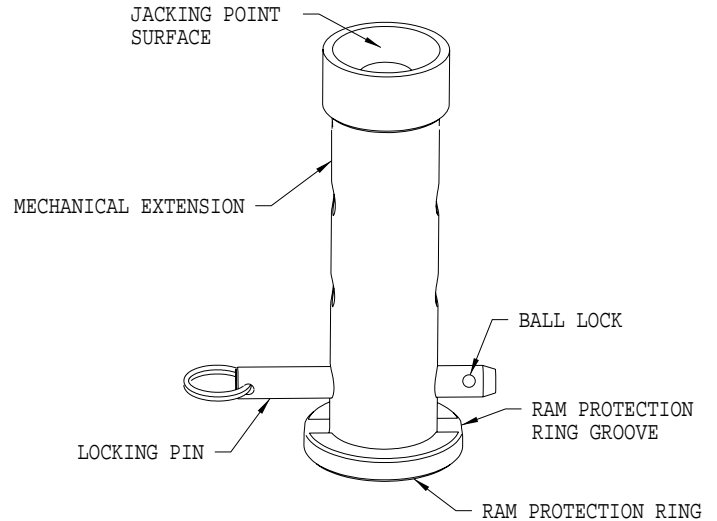

Models: 02-0522-0140 & 02A0522-0140
5 Ton (4.5 Metric Ton)
Two Stage Jack

7.4.2 Jack Instructions (continued)

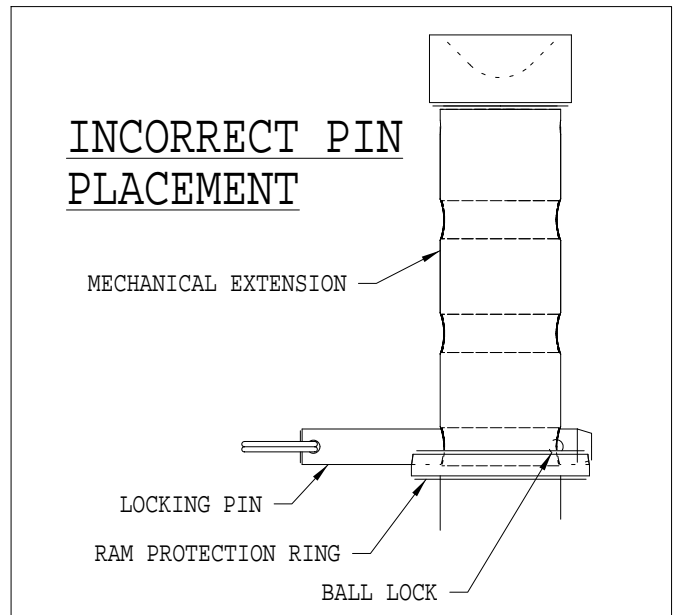
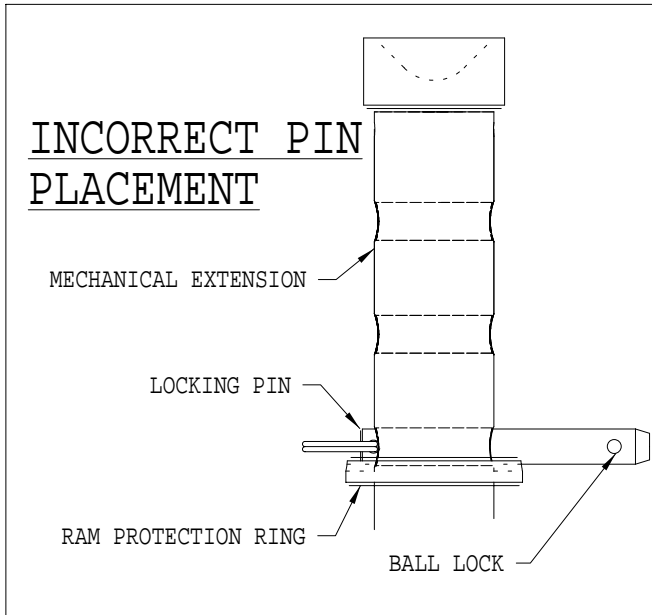

3. Close pump release valve by turning clockwise.

NOTE: *Turning the pump release valve counter-clockwise lowers the jack. Turning the pump release valve clockwise stops the jacks descent, and allows it to be raised.*

4. Operate the pump using the handle, or by opening the air valve (if equipped with an air pump).
5. Lower ram locknuts as aircraft is raised.

WARNING!



- The ram locknuts are user operated safety devices. Failure to utilize these locknuts may result in personal injury or death.
- Do not place hands on top of jack near ram locknuts while lowering jack. Pinch points exist between top of jack and threads on ram.
- Always wear safety glasses.

To Lower Aircraft:

1. Lower all jacks simultaneously.
2. If ram locking nut(s) is tight, raise jack slightly to release nut(s).
3. Loosen pump release valve slightly to slowly lower aircraft. Raise locking nut(s) as jack ram(s) lower.

NOTE: *When using jack during washing operations, completely cover top of jack near ram seal.*

8.0 TRAINING

Training of operating personnel is the responsibility of the employer. This jack must be used in accordance with aircraft manufacturer's instructions.

TRONAIR

11/2004 - AA - Rev. 04

Models: 02-0522-0140 & 02A0522-0140
5 Ton (4.5 Metric Ton)
Two Stage Jack

9.0 MAINTENANCE

9.1 GENERAL

- All maintenance and/or repair work should be done using good workmanship practices and proper tools.
- The work area should be clean and free of dirt.
- When O-rings and backup rings are removed, every effort should be made to avoid the contact of tools with the critical surfaces of parts. Surface deformities could cause degradation of seals and failure.
- It is good practice to replace both O-rings and backup rings once removed. Cut and damaged O-rings normally result in fluid leakage.
- If either cylinder and /or first stage ram bore is found to be rusty, they may be honed; the cylinder to a maximum of 3.029 inches (7.694 cm) and the first ram stage to a maximum diameter of 2.383 inches (6.053 cm). Surface finish of both bores to be 16 micro inches. If pitting in the bores cannot be removed by this process, the jack cylinder and/or first stage ram must be replaced before the jack can be returned to service.
- At this time, flush old hydraulic fluid and dirt from overall system and replenish with new, clean hydraulic fluid.
- When refilling the hydraulic system the characteristics of the hydraulic fluid used in the jack and the level of the hydraulic fluid as it is noted on the jack shall be observed.
- Jacks shall be maintained and repaired in accordance with the manufacturers instructions. Such maintenance and repair shall be carried out by qualified persons.
- No modifications shall be carried out which adversely affect the compliance of the jack with draft standard prEN 1494:1994.

9.2 MAINTENANCE SCHEDULE

Check Fluid Level.....	Each Use
Lubricate Casters	3 Months
Cleaning	Annually Or As Needed

NOTE: *Wipe with soft cloth only, do no pressure wash or spray water directly at ram seal.*

9.2.1 Storage/Low Usage

If jack is unused for 90 days, raise ram to full hydraulic extension, spray ram with DoALL RPM, LPS or equivalent water repellent, BUNA N compatible lubricant.

9.3 SERVICING JACK

To Disassemble Jack for Seal Replacement:

1. Raise first stage ram high enough to allow removal of the retaining snap ring.
2. Raise both first and second stage rams at the same time to the point where this assembly can be lifted from the jack cylinder.

NOTE: *If the second stage ram is allowed to precede the first stage ram, it will fill with oil causing an oil spill when the assembly is removed from the cylinder.*

To Re-Assemble Jack:

1. Re-assemble in reverse order of above.
2. Spray inside diameter of cylinder and outside diameter of rams (Items 14, 38 & 39) with DoALL RPM, LPS or equivalent water repellent that will not harm the BUNA "N" O-rings to protect surfaces from rusting when not in use.

NOTE: *To minimize air entrapment under the rams, raise the oil level in the cylinder to chamfer of the cylinder prior to ram insertion.*

3. Lightly peen first thread on second stage ram to prevent nut removal after seal kit installation.

NOTE: *Dispose of hydraulic fluid per local and federal regulations.*



**Models: 02-0522-0140 & 02A0522-0140
5 Ton (4.5 Metric Ton)
Two Stage Jack**

9.0 MAINTENANCE *(continued)*

9.4 REMOVING AND SERVICING PUMP

NOTE: *If pump is found faulty, call the factory for replacement or replace seals as follows:*

1. Review Appendix III HC-1752 Hand Pump Parts List.
2. Clamp suction (push on) hose and remove hose from pump.
3. Uncouple fitting of hydraulic hoses from pump.
4. Remove pump from jack.
5. Remove cotter pin from clevis pin.
6. Remove four (4) socket head cap screws.
7. Remove flanges.
8. Remove tube assembly.
9. Replace O-rings and backup ring. (See Appendix III for kits available.)
10. Re-assemble in reverse order.

9.5 JACK FUNCTION LOAD TEST

NOTE: *If function load testing is required:*

1. Take all necessary precautions to prevent injury.
2. Always jack against a load and **never** against the jack itself.
3. Do not exceed a test load equal to the jack rated capacity plus 10%.

9.6 PNEUMATIC PUMP

See Appendix II Haskel Air Pump Manufacturer Data for complete parts list and repair information.

10.0 TROUBLE SHOOTING

Ram will not rise or rises erratically

PROBABLE CAUSE	CORRECTIVE ACTION
High pressure leaks (at joint, plugs or tubing)	Re-tighten or repair
Leaky discharge check valve	Open release valve. Pump rapidly to dislodge. Or repair pump.
Leaky ram O-ring packing	Replace packing (<i>Reference Parts List – K-1035 Kit</i>)
Leaky release valve	Tighten release valve (<i>See Appendix III</i>)
Leaky pump O-ring packing	Repair pump (<i>See Appendix III</i>)
Lack of oil	Refill reservoir with oil (MIL-H-5606). Check system for leaks.
Sticking inlet check valve	Open release valve. Pump rapidly to dislodge. Or repair pump.
Air in hydraulic system	Bleed system. With rams fully retracted, open release valve. Pump rapidly and close release valve.

10.0 Trouble shooting continued on following page.



Models: 02-0522-0140 & 02A0522-0140
5 Ton (4.5 Metric Ton)
Two Stage Jack

10.0 TROUBLE SHOOTING *(continued)*

Jack will not lower

PROBABLE CAUSE	CORRECTIVE ACTION
Ram lock nut not loosened	Rotate nut as ram is lowered
Broken pump release valve	Repair pump <i>(See Appendix III)</i>
Bent ram	Replace suspected ram assembly
O-ring (Pinched or rolled)	Replace packing <i>(See Parts List – K-1035 Kit)</i> Check cylinder and rams for rust and pitting on inside diameter walls. <i>(See Section 9.0 Maintenance/General)</i>

11.0 PROVISION OF SPARES

Recommended Spares to be kept on hand:

- K-1035 Kit, Ram Seal Replacement
- K-1001 Kit, Pump Seal Replacement
- HK-1685 Kit, Repair Fluid Seal (Air Option only)
- HK-1686 Kit, Repair Air Seal (Air Option only)

Spare parts may be obtained from the manufacturer:

TRONAIR , INC. 1740 Eber Road Holland, Ohio 43528-9794 USA	Telephone: 419-866-6301 or 800-426-6301 Fax: 419-867-0634 Email: mail@tronair.com
---	---

12.0 PARTS LIST

Reference Pages 12 to 16 for Parts Lists and Illustrations.

When ordering Replacement Parts/Kits, please specify Model & Serial Number of your product.

13.0 IN-SERVICE SUPPORT

Contact Tronair for technical services and information.

14.0 GUARANTEES

Tronair products are warranted to be free of manufacturing or material defects for a period of one year after shipment to the original customer. This warranty does not cover the following items:

- a) Parts required for normal maintenance
- b) Parts covered by a component manufacturers warranty

If you have a problem that may require service, contact Tronair immediately. Do not attempt to repair or disassemble a product without first contacting Tronair, since any action may affect warranty coverage.

When you contact Tronair be prepared to provide the following information:

- a) Product Model Number
- b) Product Serial Number
- c) Description of the problem

If warranty coverage is approved, either replacement parts will be sent or the product will have to be returned to Tronair for repairs. If the product is to be returned, a Return Material Authorization Number (RMA) will be issued for reference purposes on any shipping documents. A decision on the extent of warranty coverage on returned products is reserved pending inspection at Tronair. Any shipments to Tronair must be shipped freight prepaid. Freight costs on shipments to customers will be paid by Tronair on any warranty claims.



Models: 02-0522-0140 & 02A0522-0140
5 Ton (4.5 Metric Ton)
Two Stage Jack

15.0 APPENDICES

APPENDIX I	Hydraulic Schematic
APPENDIX II	Haskel Air Pump Manufacturer Data
APPENDIX III	HC-1752 Hand Pump Parts List
APPENDIX IV	Material Safety Data Sheet – MIL-H-5606 Hydraulic Fluid

Models: 02-0522-0140 & 02A0522-0140
 5 Ton (4.5 Metric Ton)
 Two Stage Jack

Parts List

When ordering Replacement Parts/Kits, please specify Model & Serial Number of your product.

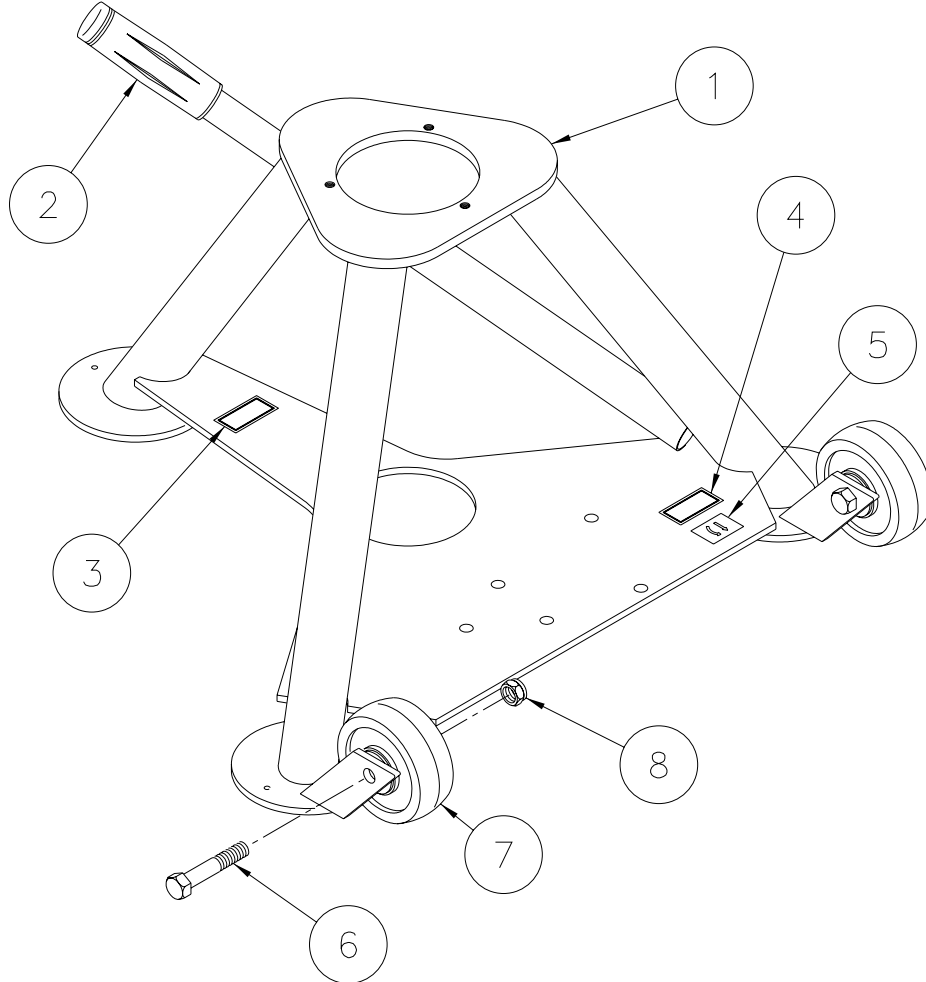

ITEM	PART NUMBER	DESCRIPTION	QTY
2.....	H-1009-01	Assembly, Pump Handle	1
3.....	V-1001.....	Label, Made in USA	1
4.....	V-1775.....	Label, Pump Force	1
5.....	V-1776.....	Label, Down.....	1
6.....	G-1100-109526	Bolt, Hex Head, Grade 5, 1/2-20 x 2 3/4" long.....	2
7.....	U-1002	Wheel	2
8.....	G-1203-1095.....	Jamnut, 1/2-20 Elastic.....	2
1	K-1333	Kit, Jack Weldment Replacement; consists of:	
.....	Z-4799-01.....	Weldment, Jack (includes labels).....	1

TRONAIR

11/2004 - AA - Rev. 04

Models: 02-0522-0140 & 02A0522-0140
5 Ton (4.5 Metric Ton)
Two Stage Jack

Parts List

When ordering Replacement Parts/Kits, please specify Model & Serial Number of your product.

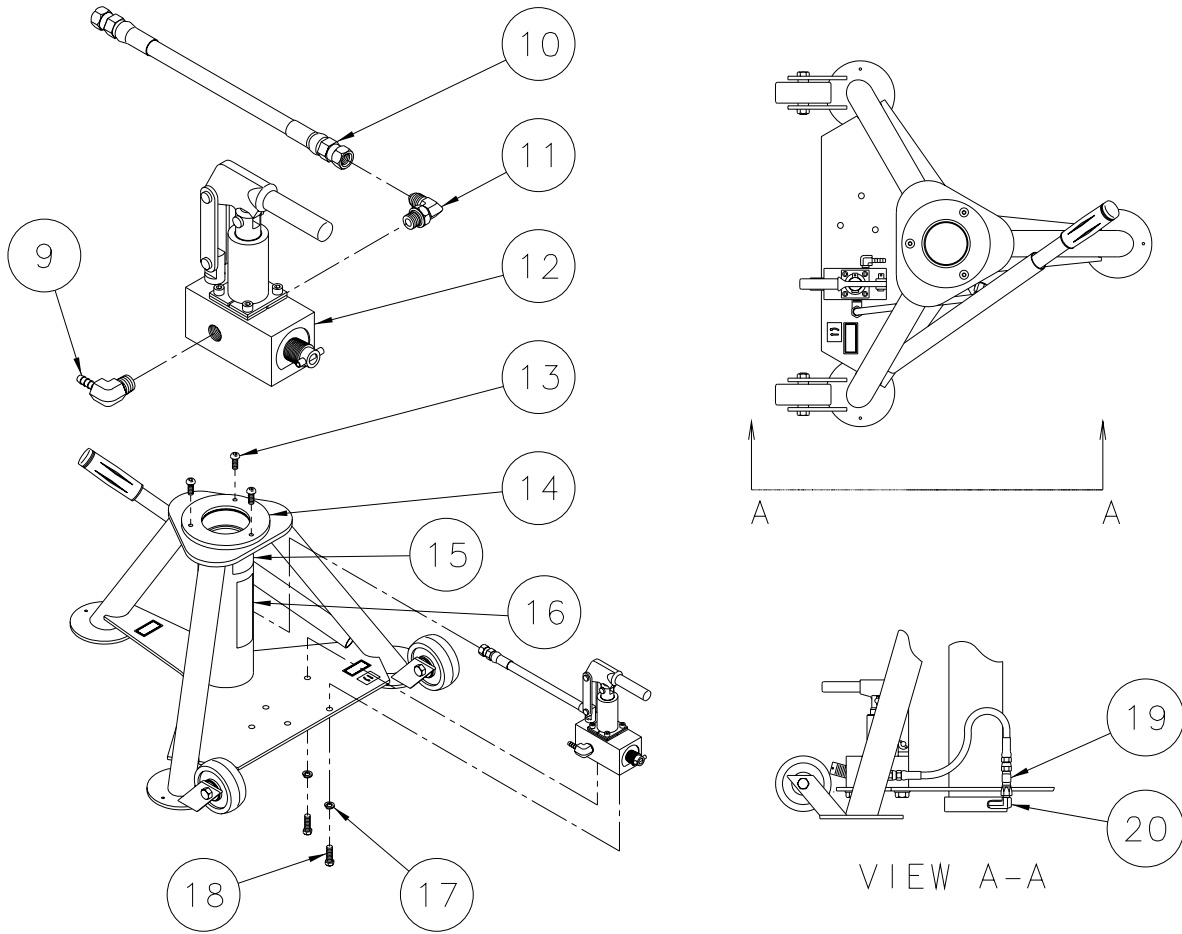

ITEM	PART NUMBER	DESCRIPTION	QTY
10	TF-1043-03*21.0	Assembly, Hose	1
13	G-1154-107210	Screw, Hex Socket Head Cap, 3/8" -16 x 1" long	3
14	Z-1558-01-01	Weldment, Tube	1
15	V-1003	Label, Serial Number	1
16	V-1198-02	Label, Tronair	1
19	N-2016-05-S	Tee, Swivel Nut Run	1
20	N-2004-06-S	Elbow, Extra Long 90° Male	1
	K-1987	Kit, Pump Replacement; consists of:	
9	N-2410-11	Elbow, 90° Male	1
11	N-2001-08-S-B	Elbow, 90° Male	1
12	HC-1752	Pump, Hydraulic Hand	1
17	G-1251-1070R	Lockwasher, 3/8" Regular	2
18	G-1100-107010	Bolt, Hex Head, Grade 5, 3/8" -16 x 1" long	2
Not Shown	TF-1047-01*05.5	Hose, Push-on	1

**Models: 02-0522-0140 & 02A0522-0140
5 Ton (4.5 Metric Ton)
Two Stage Jack**

Parts List

When ordering Replacement Parts/Kits, please specify Model & Serial Number of your product.

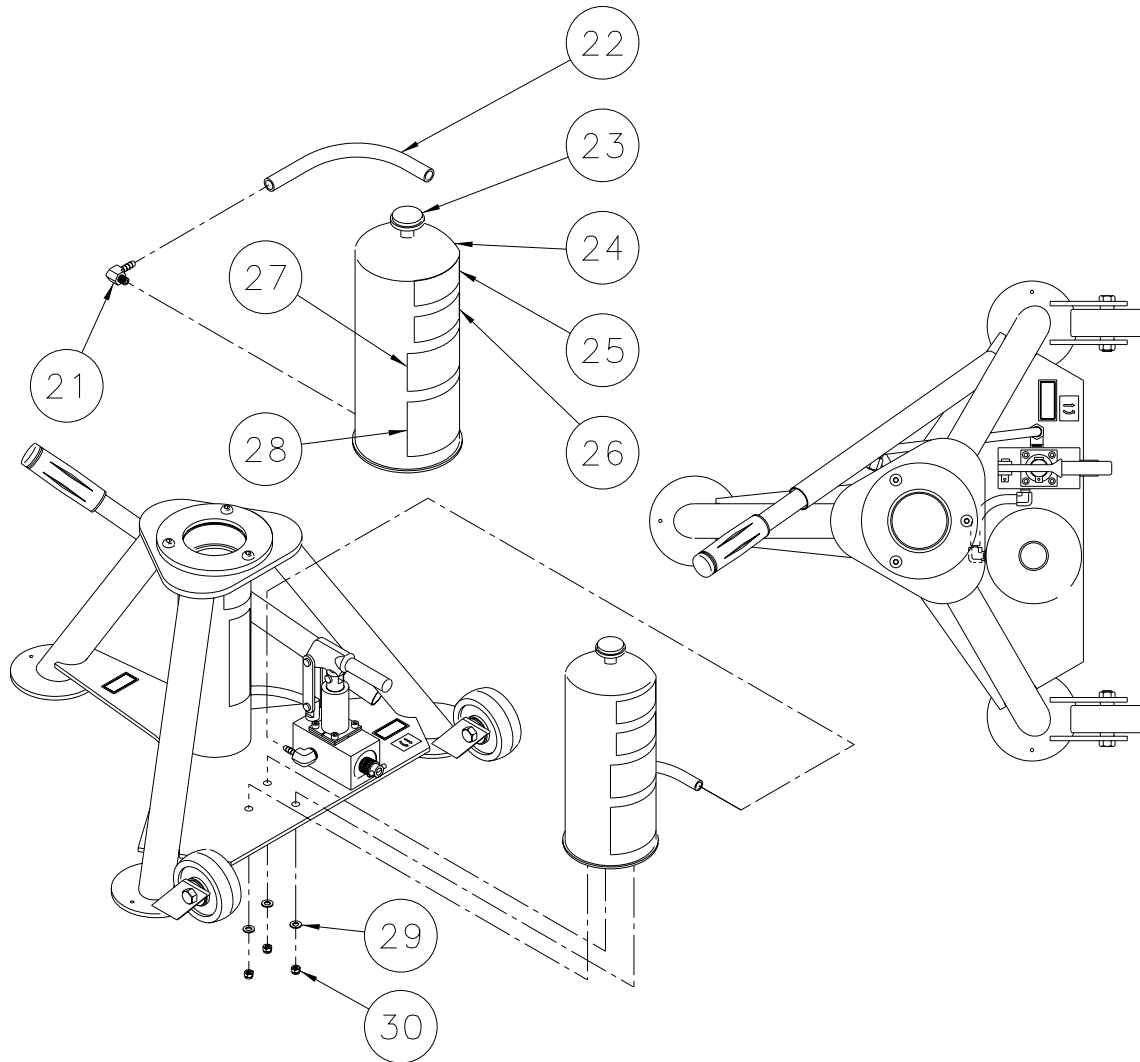

ITEM	PART NUMBER	DESCRIPTION	QTY
	K-1061-04	Kit, Reservoir Replacement; consists of:	
21.....	N-2410-01	Elbow, 90° Male	1
22.....	TF-1047-01*05.5.....	Hose, Push-on.....	1
23.....	H-1045	Breather.....	1
24.....	Z-1539-04-01	Weldment, Reservoir (includes Labels)	1
25.....	V-1102-01	Label, "Use MIL-H-5606"	1
26.....	V-1016.....	Label, "Capacity 10,000 lbs"	1
27.....	V-1819.....	Label, Hydraulic Jack Caution.....	1
28.....	V-1820.....	Label, Hydraulic Jack Instruction	1
29.....	G-1250-1050N	Flatwasher, ¼ Narrow	3
30.....	G-1202-1050	Stopnut, ¼-20 Elastic	3

Models: 02-0522-0140 & 02A0522-0140
5 Ton (4.5 Metric Ton)
Two Stage Jack

Parts List

When ordering Replacement Parts/Kits, please specify Model & Serial Number of your product.

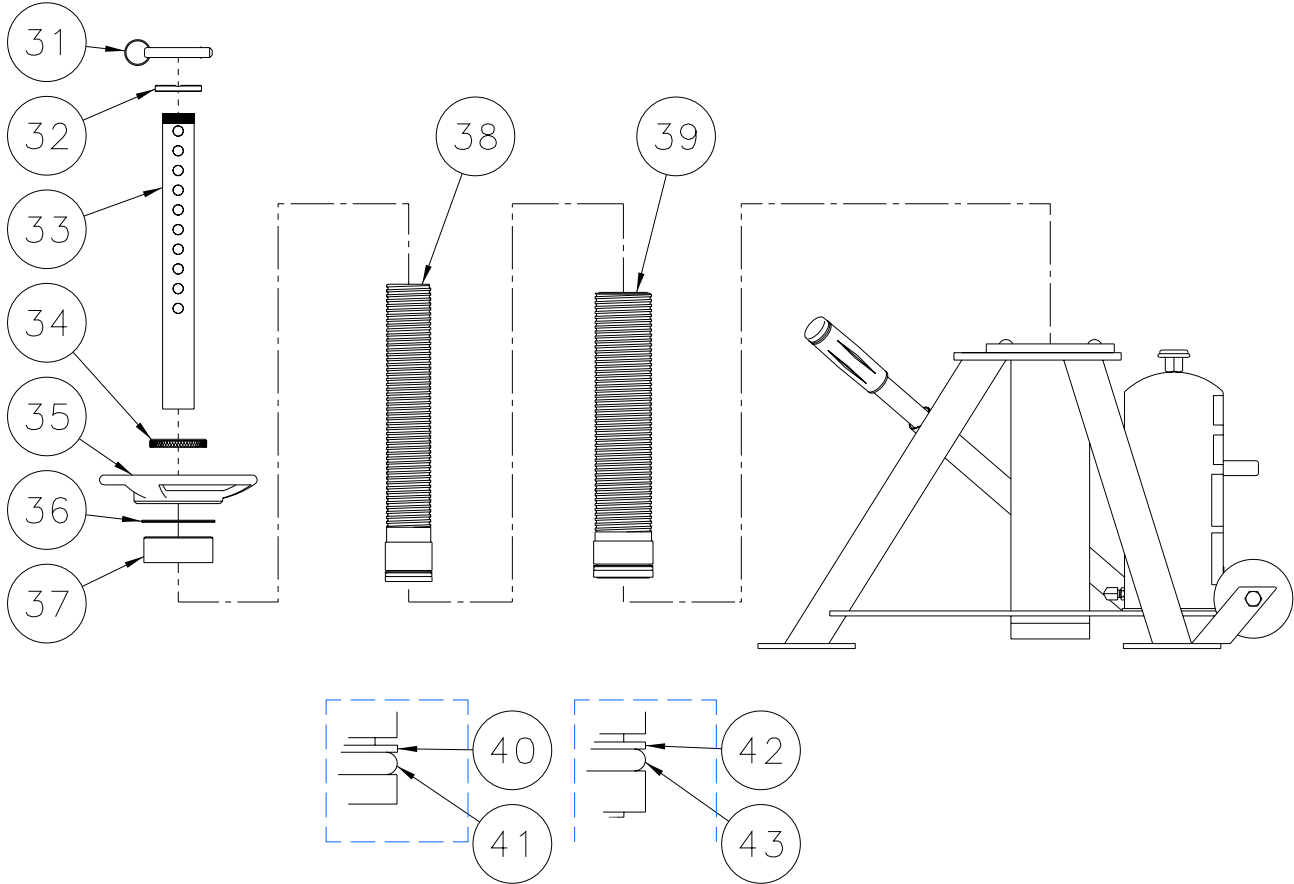

ITEM	PART NUMBER	DESCRIPTION	QTY
31	G-1307-0825	Pin, ½ x 2.5" Model "C"	1
32	TR-1026	Ring, Ram Protection	1
33	R-1013-02	Shaft, Extension	1
34	TR-1311	Stopnut, Ram	1
35	H-2335	Stopnut, Ram	1
36	G-1390	Ring, Retaining	1
37	TR-1159	Stop, Jack	1
38	Z-2229-01	Assembly, Second Stage Ram	1
39	Z-2230-01	Assembly, First Stage Ram	1
	K-1035	Kit, Ram Seal Replacement; consists of:	
40	HC-2020-329	Ring, Backup	1
41	HC-2000-329	O-ring	1
42	HC-2020-334	Ring, Backup	1
43	HC-2000-334	O-ring	1
	K-2017	Kit, Jack Pad Replacement; consists of:	
Not Shown	R-1239	Pad, Jack	1

Models: 02-0522-0140 & 02A0522-0140
5 Ton (4.5 Metric Ton)
Two Stage Jack

Parts List

When ordering Replacement Parts/Kits, please specify Model & Serial Number of your product.

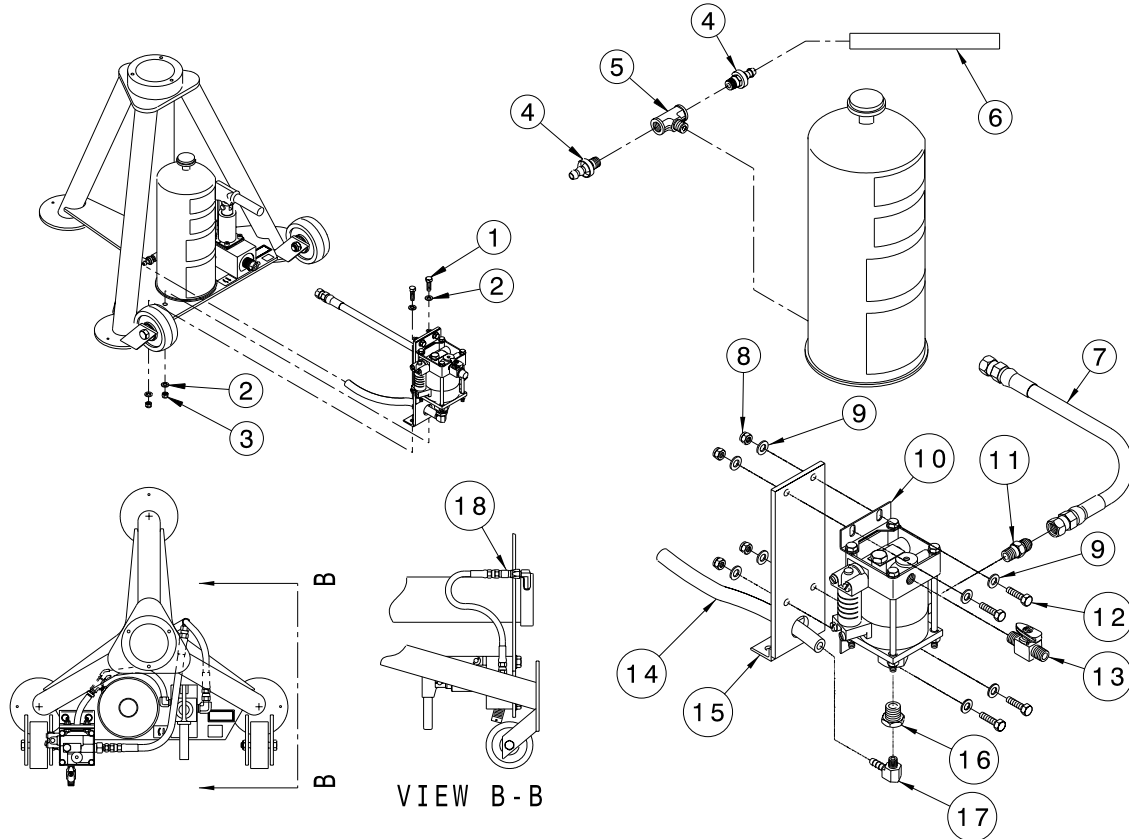

ITEM	PART NUMBER	DESCRIPTION	QTY
4	N-2412-04	Connector, Straight Male, ¼ Hose x 1/8 NPT	2
5	N-2208-01-S	Tee, Male Branch, 1/8 NPT	1
6	TF-1047-01*05.0	Hose, ¼ Gray x 5" long	1
18	N-2016-05-S	Tee, Run Swivel Nut	1
	Z-4621	Assembly, Air Pump; consists of:	
1	G-1100-106512	Bolt, Hex Head, Grade 5, 5/16 -24 x 1 ¼ " long	2
2	G-1250-1060N	Flatwasher, 5/16 Narrow	4
3	G-1202-1065	Stopnut, 5/16 -24 Elastic	2
7	TF-1043-03*15.0	Assembly, Hose	1
8	G-1202-1055	Stopnut, ¼-28 Elastic	4
9	G-1250-1050N	Flatwasher, ¼ Narrow	8
10	H-1174	Pump, Air	1
11	N-2009-08-S	Connector, Male, 3/8 -37° JIC x ¼ NPT	1
12	G-1100-105510	Bolt, Hex Head, Grade 5, ¼-28 x 1" long	4
13	H-1173	Plug, Valve	1
14	TF-1047-01*06.5	Hose, ¼ Gray x 6 ½" long	1
15	J-3415-01	Bracket, Air Pump	1
16	N-2210-04-S	Reducer, 3/8 NPT x 1/8 NPT	1
17	N-2410-01	Elbow, 90° Male, ¼ Hose x 1/8 NPT	1



APPENDIX I

Hydraulic Schematic

Models: 02-0522-0140 & 02A0522-0140
5 Ton (4.5 Metric Ton)
Two Stage Jack

Hydraulic Schematic

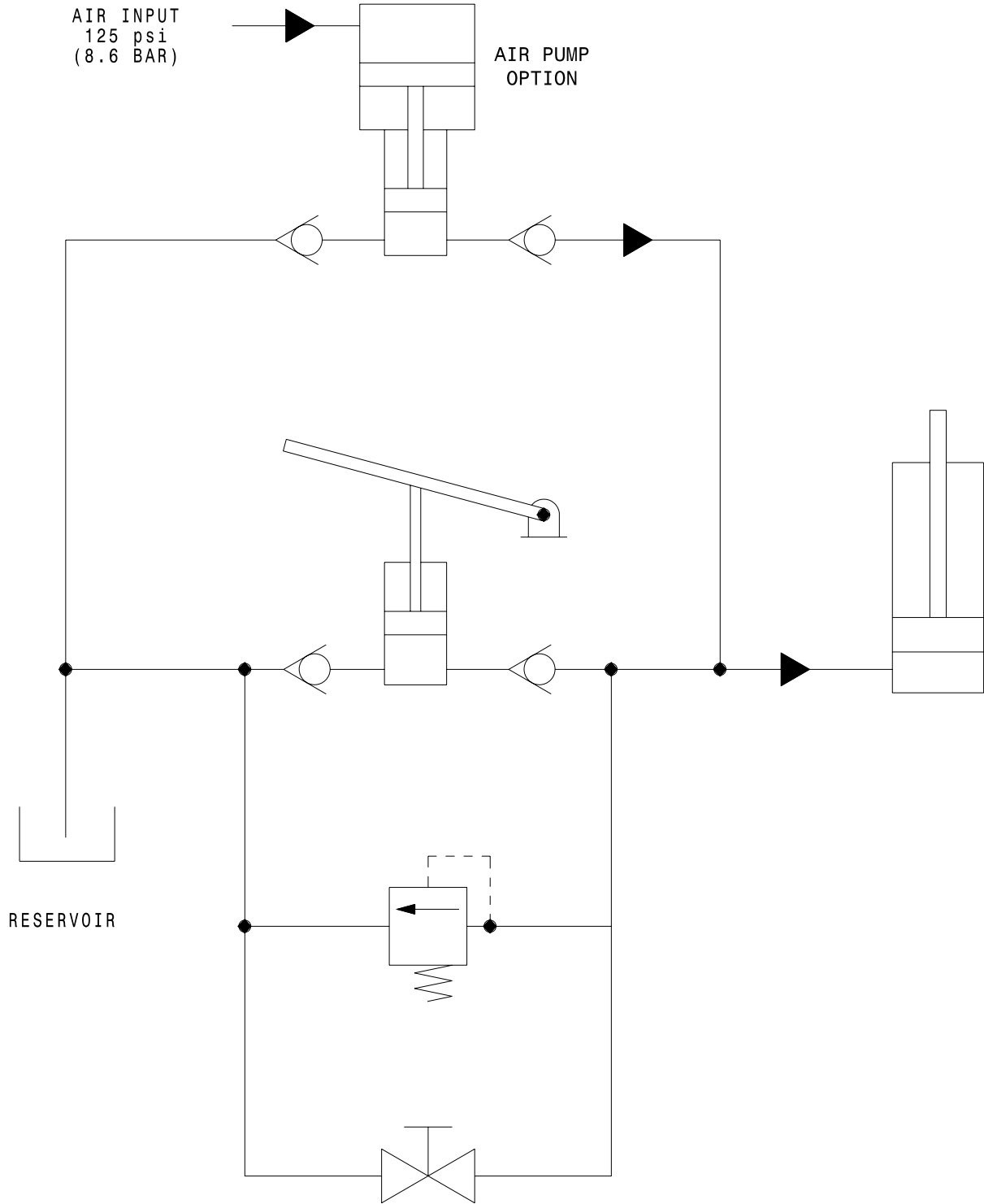



APPENDIX II

**Haskel
Air Pump
Technical
Specifications
& Performance Data**

Drawing 28550

Haskel

Technical Specifications & Performance Data

1/3 HP PUMP SERIES

M, MS, MCPV, MDSTV, 29723 models

INTRODUCTION

This brochure should be read in conjunction with Catalog MLP-46 and the assembly drawings when supplied as part of the O/M manual with a pump.

INSTALLATION

The Haskel pump can be mounted in any position and be secured by the two mounting brackets. Alternatively, the hydraulic inlet can be directly mounted to a tank top. However, models with separation chamber construction (all MD, MCPV and 29723 models) should be mounted vertically so that any fluid leakage from the chamber vent port will not migrate into the air drive section. Pump can be mounted in a horizontal position providing the vent port is facing down. Do not pipe vent port back to fluid source.

AIR DRIVE SYSTEM

Other gases such as Nitrogen, CO₂, Natural Gas – even Sour Gas can be used as alternatives to compressed air when properly modified.

The air drive requires a minimum pressure of 25 psi (1.72 bar) to actuate the air cycling valve spool. However, 40 psi is the recommended minimum for long term reliable operation. The maximum air drive pressure is 125 psi (8.6 bar). It is not necessary or desirable to use an airline lubricator. The air drive section of all Haskel liquid pumps are prelubricated at the time of assembly with Haskel lubrication 28442. The air drive requires no other means of lubrication. Install an air line filter and pressure regulator with a minimum of 1/4" npt port size. Also review air system upstream and eliminate any restrictions to provide 1/4" minimum inside diameter. Install a shut-off/speed control valve, 1/4" npt, at pump inlet port.

HYDRAULIC SYSTEM

Note: Inlet fluid supply piping should not be less than 1/4" I.D. restricting the fluid supply will result in lower outlet flow rates and cause pump to cavitate.

Larger piping should be used with heavy fluids or if suction lift is over 3 feet.

Caution: Do not loosen liquid inlet or liquid outlet fittings of pump to facilitate make up of piping connections. These fitting must be tight to avoid leakage or damage. A suction filter must be installed in liquid inlet line. 100 x 100 mesh in normally ample to protect the pump seals and check valves.

Hand pump attachment
optional for all models

1/3 HP M- or -MS series
-21 through - 188 models

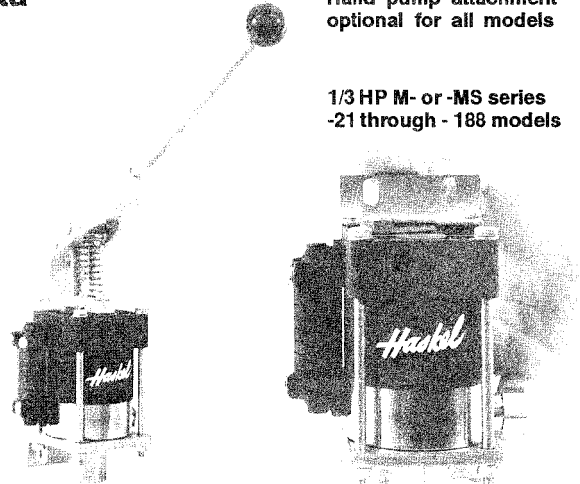

PRIMING

Install a valve of suitable working pressure to the pump outlet that is capable of being used as an air bleed to start up. Open air control valve slowly. Allow pump to cycle for approximately fifteen seconds pumping fluid through the valve. If adequately primed, close the valve. The pump will cycle slower and then stall due to increase in output resistance. If pump does not stall, open the valve and repeat the procedure.

OPERATION

The pump model number indicates the ratio between the area of the of the air piston and the liquid piston.

The liquid outlet pressure can be controlled quite accurately by regulating the air drive pressure. The pump will cycle rapidly initially and as it approaches an output pressure equal to the ratio times the air drive pressure, it will gradually slow down and finally "stall".

Where it is necessary to obtain maximum outlet flow rates up to a predetermined pressure, a Haskel Air Pilot Switch should be installed at the pump outlet to automatically stop the pump at the final pressure. The airline regulator should be set at 125 psi (8.6 bar). A Haskel relief valve to prevent over pressurization should also be fitted as a safety precaution.

Note: A hand pump attachment can be fitted (for precision control or use without compressed air power) on all models.

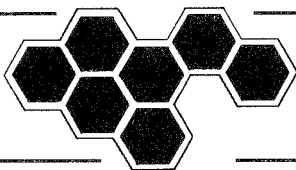

Our products are backed by outstanding technical support, an excellent reputation for reliability, and world-wide distribution.

MAINTENANCE (Continued from page 1)

Disconnect pump from system and remove to a clean, well lit work bench with access to vice, tools, seal kits and spares. All parts removed for inspection should be washed in a suitable de-greasing agent such as Stoddard solvent or equivalent. Inspect all moving parts for wear or scratches. Damaged parts should be replaced. It is recommended that all seals and O-rings are replaced. Specially packed seal kits are available for:

Air Drive P/N 17178 (common to all standard models)

HYDRAULIC SECTION

P/N 17179 (plus ratio no.)

P/N 26410 (plus ratio no.)

P/N 28247 (plus ratio no.)

P/N 51104 (plus ratio no.)

P/N 27901

P/N 53694

P/N 28696

P/N 28695

P/N 51239

P/N 51240

Model No.

M-21 thru -188

MS-21 thru -188

MCPV-21 thru -110

29723-21 thru -110

MDTV-5, MDSTV-5

M-5

M-7

MS-7

MS-12

Air Drive Section

The air piston has a spring return. Care should be taken when dismantling to prevent the spring from causing the top cap to fly off. The most common cause of air drive malfunction is O-ring 568011-21 on the end of spool 17157. Inspect this first and replace if necessary prior to retesting before further disassembly of air drive. Spool 17157 is most easily removed by removing the muffler upper cap and carefully opening the air drive valve to push the spool and sleeve assembly out with compressed air. The spool and sleeve can be contained by holding a cloth over the exhaust port. The air piston, air barrel, cycling valve and sleeve should be relubricated on assembly with Haskel Silicone Grease P/N 28442. Torque the tie rod nuts evenly to 50 in. lbs.

Hydraulic Section

If dismantled for inspection and parts replacement use following torque values on re-assembly.

Inlet check valve — ratios -7, -12 to 95 ft. lbs.

Inlet check valve — ratios -21, -36 to 50 ft. lbs.

Inlet check valve — ratios -71, -110, -188 to 125 ft. lbs.

Outlet check valves — all ratios to 50 ft. lbs.

When ordering spare parts advise pump serial no., model no., spare part no., and description.

TROUBLE SHOOTING GUIDE

Pump will not cycle, pump bypasses air.

- Inadequate air
 - a. See comments on: Air drive systems, page 1 and air drive section, on this page.
- Contaminated air system
 - a. Remove sleeve and cycling spool (under upper cap of

muffler). Clean, inspect and lubricate with Haskel Lubricant 28442.

False cycle, leak from pilot exhaust (top center of cap).

- Leakage of pilot system.
Install new air section seal kit.

Pump cycles without pumping or does not stall.

- Check valve(s) not seating or leak in system.
Inspect check valve(s). First inlet check and then outlet check.

Pump fluid appears at muffler (or vent port on separation models).

- High pressure seal leakage.
Install new liquid section seal kit.

Cross section of Haskel M- and MS- Series Pump

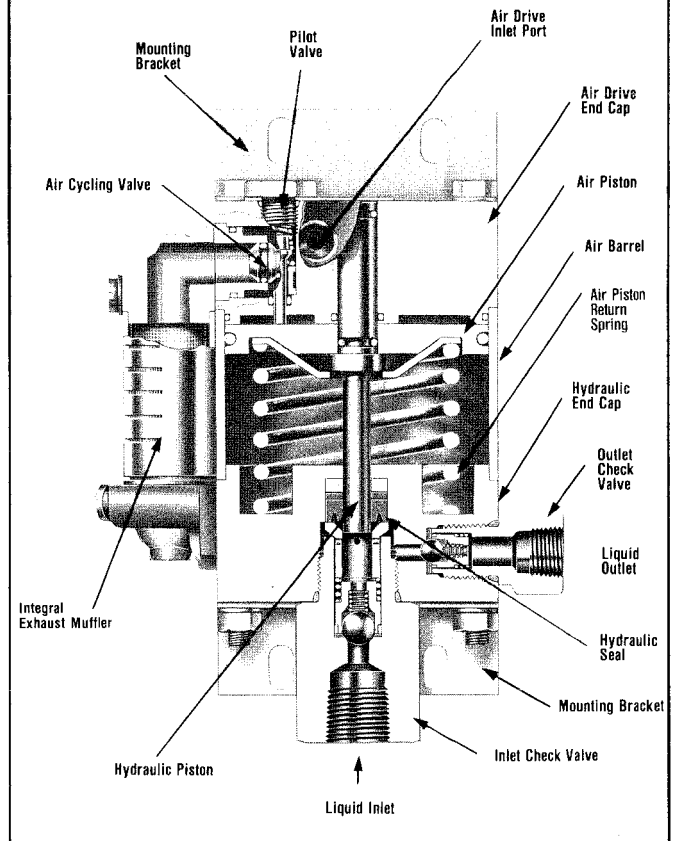

LIMITED WARRANTY

Haskel manufactured products are warranted free of original defects in material and workmanship for a period of one year from date of shipment to first user. This warranty does not include packings, seals, nor failures caused by lack of proper maintenance; incompatible fluids; foreign materials in the driving media; in the pumped media; or application of pressures beyond catalog ratings. Products believed to be originally defective may be returned, freight prepaid, for repair and/or replacement to the distributor, authorized service representative, or to the factory. If upon inspection by the factory or authorized service representative, the problem is found to be originally defective material or workmanship, repair or replacement will be made at no charge for labor or materials, F.O.B. the point of repair or replacement. Permission to return under warranty should be requested before shipment and include the following: the original purchase date, purchase order number, serial number, model number, or other pertinent data to establish warranty claim, and to expedite the return or replacement to the owner.

If pump has been disassembled and reassembled in a facility other than Haskel, warranty is void if it has been improperly reassembled or substitute parts have been used in place of factory manufactured parts.

Any modification to any Haskel product which you have made or may make in the future has been and will be at your sole risk and responsibility, and without Haskel's approval or consent. Haskel disclaims any and all liability, obligation, or responsibility for the modified product; and for any claims, demands, or causes of action for damage or for personal injuries resulting from the modification and/or use of such a modified Haskel product.

HASKEL'S OBLIGATION WITH RESPECT TO ITS PRODUCTS SHALL BE LIMITED TO REPLACEMENT, AND IN NO EVENT SHALL HASKEL BE LIABLE FOR ANY LOSS OR DAMAGE, CONSEQUENTIAL OR SPECIAL, OF WHATEVER KIND OR NATURE, OR ANY OTHER EXPENSE WHICH MAY ARISE IN CONNECTION WITH OR AS A RESULT OF SUCH PRODUCTS OR THE USE OR INCORPORATION THEREOF IN A JOB. THIS WARRANTY IS EXPRESSLY MADE IN LIEU OF ALL OTHER WARRANTIES OF MERCHANTABILITY AND FITNESS FOR A PARTICULAR PURPOSE. NO EXPRESS WARRANTIES AND NO IMPLIED WARRANTIES WHETHER OF MERCHANTABILITY OR FITNESS FOR A PARTICULAR PURPOSE OR OTHERWISE, OTHER THAN THOSE EXPRESSLY SET FORTH ABOVE, SHALL APPLY TO HASKEL PRODUCTS.

HASKEL INTERNATIONAL INC., INDUSTRIAL TECHNOLOGIES DIVISION

Headquarters: Burbank, California 91502 USA

Tel: 818-843-4000 Fax: 818-556-2549

South East Asia Sales Office: Singapore 188720

Tel: 65-334-7079 Fax: 65-334-5072

North East Asia Sales Office: Toowong, Qld. 4066 * Australia

Tel: 61-7-3277-9174 Fax: 61-7-3277-9121

Australia Sales Office: Toowong, Qld. 4066 * Australia

Tel: 61-7-3277-9118 Fax: 61-7-3277-6129

REV	DESCRIPTION	DATE	BY	CHKD
1	ISSUE FOR PRODUCTION	12/15/78	J. L. HARRIS	
2	REVISION TO DRAWING	12/15/78	J. L. HARRIS	
3	REVISION TO DRAWING	12/15/78	J. L. HARRIS	
4	REVISION TO DRAWING	12/15/78	J. L. HARRIS	
5	REVISION TO DRAWING	12/15/78	J. L. HARRIS	
6	REVISION TO DRAWING	12/15/78	J. L. HARRIS	
7	REVISION TO DRAWING	12/15/78	J. L. HARRIS	
8	REVISION TO DRAWING	12/15/78	J. L. HARRIS	
9	REVISION TO DRAWING	12/15/78	J. L. HARRIS	
10	REVISION TO DRAWING	12/15/78	J. L. HARRIS	

28550

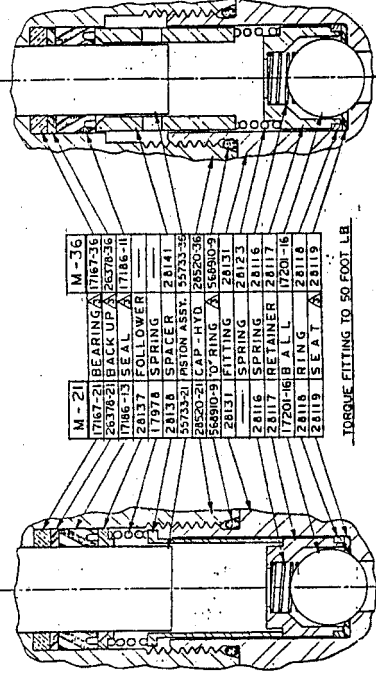
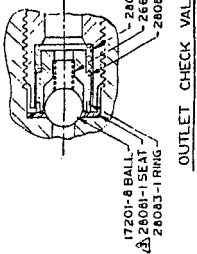

INLET CHECK VALVE M-21 AND M-36

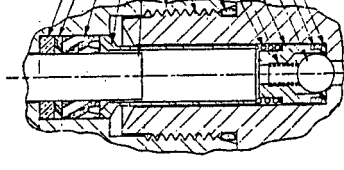

INLET CHECK VALVE M-71, M-110 AND M-188

CONTROL COPY
 LOCATION # 1

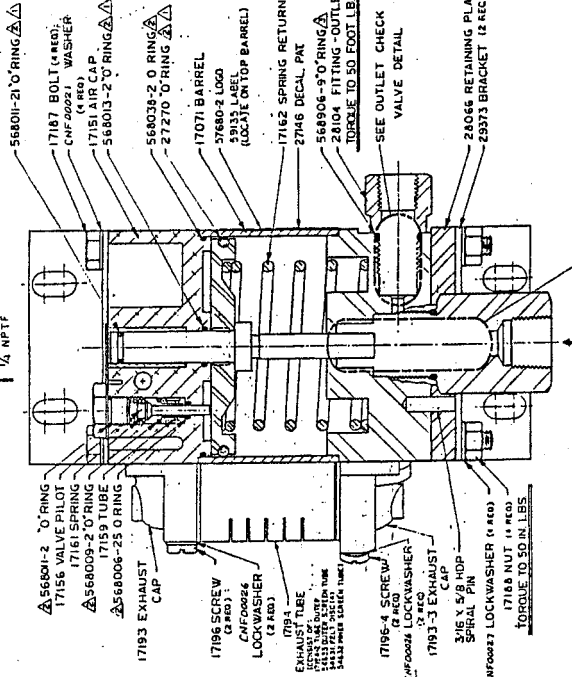
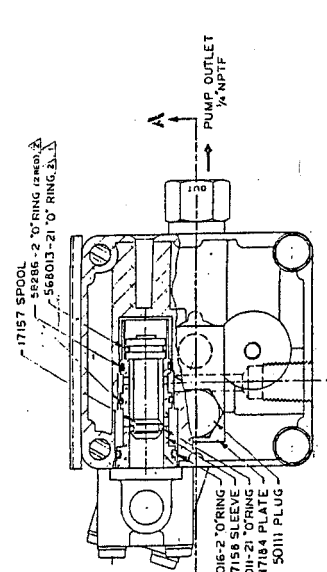

CROSS SECTION A-A

- 55763-XK TOOL MAY BE USED TO INSTALL HYD SEAL. THESE PARTS ARE INCLUDED IN 17179-XX HYDRAULIC SECTION SEALS KIT.
- THESE PARTS ARE INCLUDED IN 17178 AIR DRIVE SEALS KIT.
- APPLY VERY LIGHT COATING OF MASKEL LUBRICANT. PN 50866 TO DYNAMIC SEALS IN AIR DRIVE SECTION.

NOTE

REV	DESCRIPTION	DATE	BY	CHKD
1	ISSUE FOR PRODUCTION	12/15/78	J. L. HARRIS	
2	REVISION TO DRAWING	12/15/78	J. L. HARRIS	
3	REVISION TO DRAWING	12/15/78	J. L. HARRIS	
4	REVISION TO DRAWING	12/15/78	J. L. HARRIS	
5	REVISION TO DRAWING	12/15/78	J. L. HARRIS	
6	REVISION TO DRAWING	12/15/78	J. L. HARRIS	
7	REVISION TO DRAWING	12/15/78	J. L. HARRIS	
8	REVISION TO DRAWING	12/15/78	J. L. HARRIS	
9	REVISION TO DRAWING	12/15/78	J. L. HARRIS	
10	REVISION TO DRAWING	12/15/78	J. L. HARRIS	

ASSEMBLY DRAWING
 MODEL M PUMP
 81400 28550

REVISIONS	
1	REVISED TO SHOW MOUNTING DIMENSIONS
2	REVISED TO SHOW MOUNTING DIMENSIONS
3	REVISED TO SHOW MOUNTING DIMENSIONS
4	REVISED TO SHOW MOUNTING DIMENSIONS
5	REVISED TO SHOW MOUNTING DIMENSIONS
6	REVISED TO SHOW MOUNTING DIMENSIONS
7	REVISED TO SHOW MOUNTING DIMENSIONS
8	REVISED TO SHOW MOUNTING DIMENSIONS
9	REVISED TO SHOW MOUNTING DIMENSIONS
10	REVISED TO SHOW MOUNTING DIMENSIONS

28550

INLET CHECKVALVE
M-50

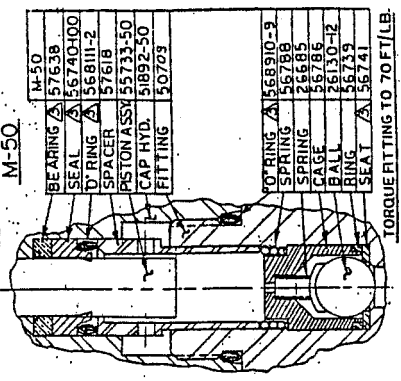

BEARING	A	M-50	57638
SEAL	A	56740-100	
O-RING	A	568111-2	
SPACER	A	57618	
PISTON ASSY	A	55733-50	
CAP HYD.	A	51892-50	
FITTING	A	50723	
O-RING	A	568910-3	
SPRING	A	56788	
SPRING	A	26685	
CAGE	A	56786	
BALL	A	26130-12	
RING	A	56739	
SEAT	A	56741	

TORQUE FITTING TO 70 FT/LB

CONTROL COPY
LOCATION # 1

TITLE ASSEMBLY DRAWING MODEL "M" PUMP	SHEET NO. 1 OF 1
DATE 11/10/50	DRAWN BY J. J. ...
CHECKED BY ...	APPROVED BY ...



APPENDIX III

HC-1752 Hand Pump Parts List



**Model: HC-1752
2,500 PSI Hand Pump**

Illustrated Parts List

08/2001 – Rev. OR

Tronair, Inc.

*1740 Eber Road
Holland, Ohio 43528-9794
USA*

Telephone: (419) 866-6301 • 800-426-6301

Fax: (419) 867-0634

Web Site: www.tronair.com E-mail: mail@tronair.com

HC-1752
2,500 PSI Hand Pump

Parts List

- This pump is compatible with MIL-H-5606 / MIL-H-83282 Hydraulic Fluids only.

Reference Parts List Illustration on Page 3.

REPLACEMENT PARTS

ITEM	PART NUMBER	DESCRIPTION	QTY
3	5M1-000-001	Body, Pump	1
12	506-000	Half, Flange	4
25	518-000	Screw, Socket Head Cap	4
Not Shown	H-1009-01	Handle	1

REPLACEMENT KITS

ITEM	PART NUMBER	DESCRIPTION	QTY
	K-1001	Kit, Seal Replacement; consists of:	
4		O-ring, Release Screw	1
6		O-ring, Outlet Check	1
11		O-ring, Valve Body	1
21		Wiper, Rod	1
22		Ring, Backup	1
23		O-ring, Piston	1
27		O-ring, Tube Seal	1
◆ Not Shown		O-ring, Inlet Check	1
◆ Not Shown		O-ring, Guide Shoe	2
◆ Not Shown		Shoe, Piston Guide	1
	K-1068	Kit, Linkage Replacement; consists of:	
13		Pivot	1
14		Assembly, Linkage Pin	2
17		Strap	2
18		Assembly, Clevis Pin	1
19		Bracket, Pump Handle	1
	K-1069	Kit, Internal Parts Replacement; consists of:	
◆ Not Shown		Ball, Release	1
7		Spring, Inlet Check	1
8		Spring, Outlet Check	1
9		Ball, Outlet Check	1
10		Ball, Inlet Check	1

- ◆ Although this item is listed in its particular kit, it is not used on HC-1752 pump. These items may be discarded.

HC-1752
2,500 PSI Hand Pump

Parts List

Reference Parts List Illustration on Page 3.

REPLACEMENT KITS

ITEM	PART NUMBER	DESCRIPTION	QTY
	K-1778	Kit, Piston/Cylinder Replacement; consists of:	
15.....		Piston.....	1
16.....		Tube	1
20.....		Retainer, Wiper	1
24.....		Assembly, Valve Body (Includes Items 7, 10, 24, 26)	1
	K-1906	Kit, Piston/Seal Replacement; consists of:	
15.....		Piston.....	1
22.....		Ring, Backup	1
23.....		O-ring, Piston	1
	K-2783	Kit, Release Screw Replacement; consists of:	
2.....		Screw, Release	1
30.....		Retainer, Screw.....	1

NOTE: Entire pump assembly can be purchased as a kit. See Hydraulic Jack Parts list.

Parts List Illustration

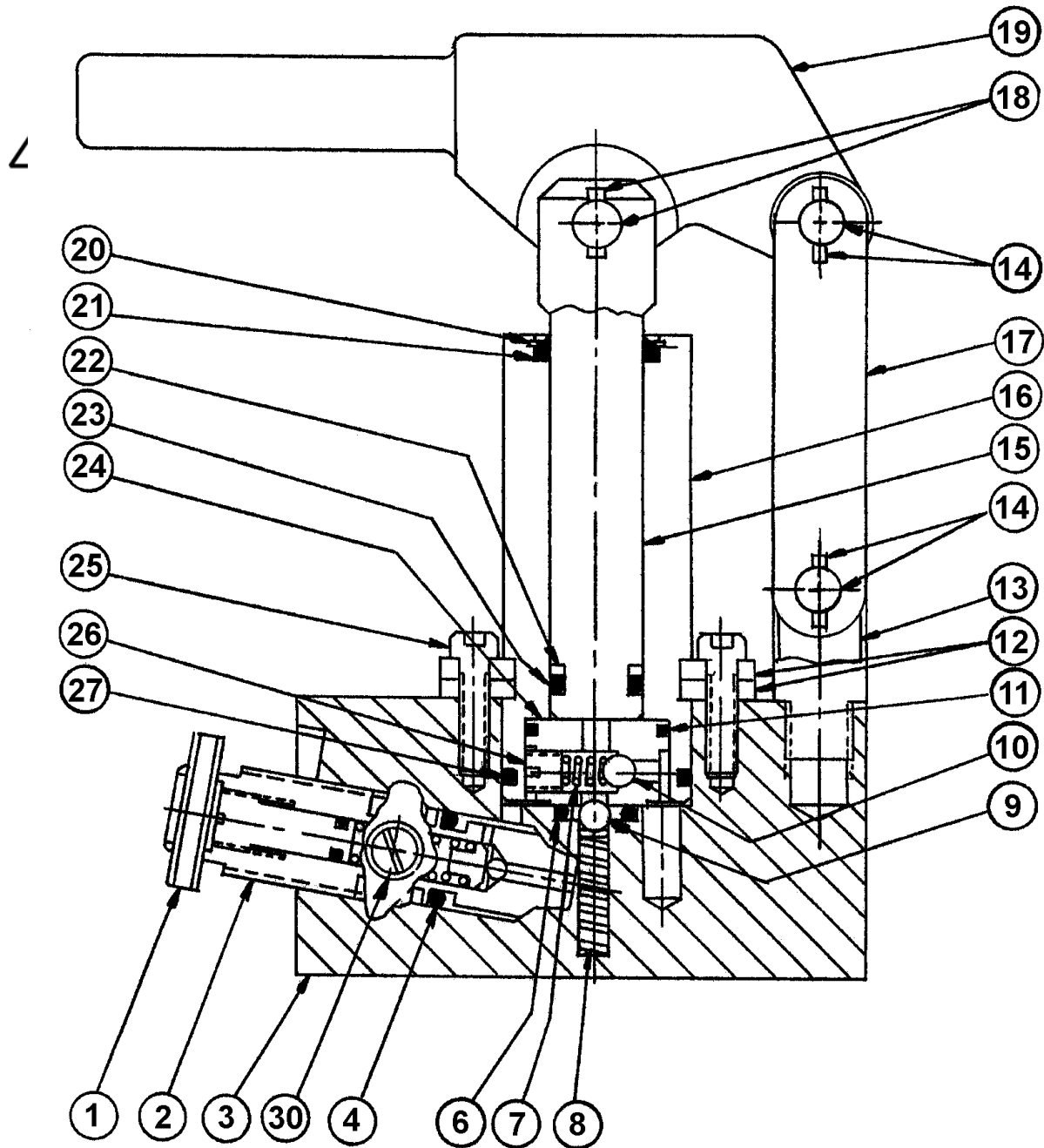

WARNING!

Item 2 is a preset relief valve. Do not disassemble this valve. Replacement parts are available as a preset relief valve assembly.



APPENDIX IV

**MSDS
Hydraulic Fluid
(MIL-H-5606)**

TRONAIR MSDS-1029



490110-00 MOBIL AERO HFA
MATERIAL SAFETY DATA BULLETIN

1. PRODUCT AND COMPANY IDENTIFICATION

PRODUCT NAME: MOBIL AERO HFA
SUPPLIER: EXXONMOBIL OIL CORPORATION
3225 GALLOWS RD.
FAIRFAX, VA 22037

24 - Hour Health and Safety Emergency (call collect): 609-737-4411

24 - Hour Transportation Emergency:
CHEMTREC: 800-424-9300 202-483-7616
LUBES AND FUELS: 281-834-3296

Product and Technical Information:
Lubricants and Specialties: 800-662-4525 800-443-9966
Fuels Products: 800-947-9147
MSDS Fax on Demand: 613-228-1467
MSDS Internet Website: <http://emmsds.ihssolutions.com/>

2. COMPOSITION/INFORMATION ON INGREDIENTS

CHEMICAL NAMES AND SYNONYMS: PET. HYDROCARBONS AND ADDITIVES

GLOBALLY REPORTABLE MSDS INGREDIENTS:

None.

OTHER INGREDIENTS:

Substance Name	Approx. Wt%
HYDROTREATED LIGHT NAPHTHENIC DISTILLATE (PETROLEUM) (64742-53-6)	85-95

See Section 8 for exposure limits (if applicable).

3. HAZARDS IDENTIFICATION

This product is considered hazardous according to regulatory guidelines
(See Section 15).

EMERGENCY OVERVIEW: Red Liquid. DOT ERG No. : NA
POTENTIAL HEALTH EFFECTS: Low viscosity material-if swallowed may

enter the lungs and cause lung damage. Prolonged repeated skin contact with low viscosity materials may defat the skin resulting in possible irritation and dermatitis.

For further health effects/toxicological data, see Section 11.

4. FIRST AID MEASURES

EYE CONTACT: Flush thoroughly with water. If irritation occurs, call a physician.

SKIN CONTACT: Wash contact areas with soap and water. Remove contaminated clothing. Launder contaminated clothing before reuse. Discard shoes if material has penetrated to inside surfaces. High pressure accidental injection through the skin requires immediate medical attention for possible incision, irrigation and/or debridement.

INHALATION: Remove from further exposure. If respiratory irritation, dizziness, nausea, or unconsciousness occurs, seek immediate medical assistance and call a physician. If breathing has stopped, use mouth to mouth resuscitation.

INGESTION: Get medical assistance and call a physician immediately. Do not induce vomiting or give anything by mouth to an unconscious person.

NOTE TO PHYSICIANS: Material if ingested may be aspirated into the lungs and can cause chemical pneumonitis. Treat appropriately.

5. FIRE-FIGHTING MEASURES

EXTINGUISHING MEDIA: Carbon dioxide, foam, dry chemical and water fog.

SPECIAL FIRE FIGHTING PROCEDURES: Water or foam may cause frothing.

Use water to keep fire exposed containers cool. Water spray may be used to flush spills away from exposure. Prevent runoff from fire control or dilution from entering streams, sewers, or drinking water supply.

SPECIAL PROTECTIVE EQUIPMENT: For fires in enclosed areas, fire fighters must use self-contained breathing apparatus.

UNUSUAL FIRE AND EXPLOSION HAZARDS: None.

COMBUSTION PRODUCTS: Fumes, smoke, carbon monoxide, sulfur oxides, aldehydes and other decomposition products, in the case of incomplete combustion.

Flash Point C(F): > 105(221) (ASTM D-93).

Flammable Limits (approx.% vol.in air) - LEL: NE, UEL: NE

NFPA HAZARD ID: Health: 1, Flammability: 1, Reactivity: 0

6. ACCIDENTAL RELEASE MEASURES

NOTIFICATION PROCEDURES: Report spills as required to appropriate authorities. U. S. Coast Guard regulations require immediate reporting of spills that could reach any waterway including intermittent dry creeks. Report spill to Coast Guard toll free number (800) 424-8802. In case of accident or road spill notify CHEMTREC (800) 424-9300.

PROCEDURES IF MATERIAL IS RELEASED OR SPILLED: Eliminate all ignition sources. Ventilate area. Adsorb on fire retardant treated sawdust, diatomaceous earth, etc. Shovel up with spark-resistant

shovel and remove to appropriate waste disposal facility in accordance with current applicable laws and regulations.
ENVIRONMENTAL PRECAUTIONS: Prevent spills from entering storm sewers or drains and contact with soil.
PERSONAL PRECAUTIONS: See Section 8

7. HANDLING AND STORAGE

HANDLING: Avoid prolonged repeated skin contact. Avoid inhalation of vapors or mists. Wash thoroughly after handling. High pressure injection under the skin may occur due to the rupture of pressurized lines. Always seek medical attention.

STORAGE: Do not store in open or unlabelled containers. Store away from strong oxidizing agents and combustible materials. Store in a cool, dry, well ventilated area away from heat.

SPECIAL PRECAUTIONS: Prevent small spills and leakages to avoid slip hazard.

EMPTY CONTAINER WARNING: Empty containers retain residue (liquid and/or vapor) and can be dangerous. DO NOT PRESSURIZE, CUT, WELD, BRAZE, SOLDER, DRILL, GRIND OR EXPOSE SUCH CONTAINERS TO HEAT, FLAME, SPARKS, STATIC ELECTRICITY, OR OTHER SOURCES OF IGNITION; THEY MAY EXPLODE AND CAUSE INJURY OR DEATH. Do not attempt to refill or clean container since residue is difficult to remove. Empty drums should be completely drained, properly bunged and promptly returned to a drum reconditioner. All containers should be disposed of in an environmentally safe manner and in accordance with governmental regulations.

8. EXPOSURE CONTROLS/PERSONAL PROTECTION

OCCUPATIONAL EXPOSURE LIMITS: When mists/aerosols can occur, the following are recommended: 5 mg/m³(as oil mist)- ACGIH Threshold Limit Value (TLV), 10 mg/m³ (as oil mist)
- ACGIH Short Term Exposure Limit (STEL), 5 mg/m³ (as oil mist) - OSHA Permissible Exposure Limit (PEL)

VENTILATION: Use in well ventilated area. If mechanical ventilation is necessary, equipment should be explosion proof.

RESPIRATORY PROTECTION: Approved respiratory protective equipment must be used when vapor or mists concentrations exceed applicable standards. No special requirements under ordinary conditions of use and with adequate ventilation.

EYE PROTECTION: Normal industrial eye protection practices should be employed.

SKIN PROTECTION: If prolonged or repeated skin contact is likely, impervious gloves should be worn. Good personal hygiene practices should always be followed.

9. PHYSICAL AND CHEMICAL PROPERTIES

Typical physical properties are given below. Consult Product Data Sheet for specific details.

APPEARANCE: Liquid
COLOR: Red

ODOR: Mild
ODOR THRESHOLD-ppm: NE
pH: NA
BOILING POINT C(F): NE
MELTING POINT C(F): NA
FLASH POINT C(F): > 105 (221) (ASTM D-93)
FLAMMABILITY (solids): NE
AUTO FLAMMABILITY C(F): NE
EXPLOSIVE PROPERTIES: NA
OXIDIZING PROPERTIES: NA
VAPOR PRESSURE-mmHg 20 C: NE
VAPOR DENSITY: NE
EVAPORATION RATE: NE
RELATIVE DENSITY, 15/4 C: 0.85
SOLUBILITY IN WATER: Negligible
PARTITION COEFFICIENT: NE
VISCOSITY AT 40 C, cSt: 13.8
VISCOSITY AT 100 C, cSt: 5.3
POUR POINT C(F): -70(-94)
FREEZING POINT C(F): NE
VOC: < 80.00 (Wt. %); 5.669 lbs/gal
NA=NOT APPLICABLE NE=NOT ESTABLISHED D=DECOMPOSES

FOR FURTHER TECHNICAL INFORMATION, CONTACT YOUR MARKETING REPRESENTATIVE

10. STABILITY AND REACTIVITY

STABILITY (THERMAL, LIGHT, ETC.): Stable.
CONDITIONS TO AVOID: Heat, sparks, flame and build up of static
electricity. Protect from direct sunlight.
INCOMPATIBILITY (MATERIALS TO AVOID): Strong oxidizers.
HAZARDOUS DECOMPOSITION PRODUCTS: Product does not decompose at
ambient temperatures.
HAZARDOUS POLYMERIZATION: Will not occur.

11. TOXICOLOGICAL DATA

---ACUTE TOXICOLOGY---

ORAL TOXICITY (RATS): Practically non-toxic (LD50: greater than 2000
mg/kg). ---Based on testing of similar products and/or the
components.
DERMAL TOXICITY (RABBITS): Practically non-toxic (LD50: greater than
2000 mg/kg). ---Based on testing of similar products and/or the
components.
INHALATION TOXICITY (RATS): Not established
EYE IRRITATION (RABBITS): Practically non-irritating. (Draize score:
greater than 6 but 15 or less). ---Based on testing of similar
products and/or the components.
SKIN IRRITATION (RABBITS): Practically non-irritating. (Primary
Irritation Index: greater than 0.5 but less than 3). ---Based
on testing of similar products and/or the components.

---SUBCHRONIC TOXICOLOGY (SUMMARY)---

Severely solvent refined and severely hydrotreated mineral base oils
have been tested at Mobil Environmental and Health Sciences
Laboratory by dermal application to rats 5 days/week for 90 days

at doses significantly higher than those expected during normal industrial exposure. Extensive evaluations including microscopic examination of internal organs and clinical chemistry of body fluids, showed no adverse effects.

---CHRONIC TOXICOLOGY (SUMMARY)---

The base oils in this product are severely solvent refined and/or severely hydrotreated. Chronic mouse skin painting studies of severely treated oils showed no evidence of carcinogenic effects. These results are confirmed on a continuing basis using various screening methods such as the Mobil Modified Ames Test and IP-346.

12. ECOLOGICAL INFORMATION

ENVIRONMENTAL FATE AND EFFECTS: This environmental assessment was conducted using information on the individual components as no test data was available for this specific formulation.

ECOTOXICITY: This material is not expected to be harmful to aquatic organisms.

MOBILITY: Dissolution of the higher molecular weight hydrocarbon components in water will be limited, but losses through sediment adsorption may be significant.

PERSISTENCE AND DEGRADABILITY: The majority of the components in this product are expected to be inherently biodegradable.

BIOACCUMULATIVE POTENTIAL: This product contains components with the potential to bio-accumulate.

13. DISPOSAL CONSIDERATIONS

WASTE DISPOSAL: Product is suitable for burning in an enclosed, controlled burner for fuel value or disposal by supervised incineration. Such burning may be limited pursuant to the Resource Conservation and Recovery Act. In addition, the product is suitable for processing by an approved recycling facility or can be disposed of at an appropriate government waste disposal facility. Use of these methods is subject to user compliance with applicable laws and regulations and consideration of product characteristics at time of disposal.

RCRA INFORMATION: The unused product, in our opinion, is not specifically listed by the EPA as a hazardous waste (40 CFR, Part 261D), nor is it formulated to contain materials which are listed hazardous wastes. It does not exhibit the hazardous characteristics of ignitability, corrosivity, or reactivity. The unused product is not formulated with substances covered by the Toxicity Characteristic Leaching Procedure (TCLP). However, used product may be regulated.

14. TRANSPORT INFORMATION

USA DOT: NOT REGULATED BY USA DOT.

RID/ADR: NOT REGULATED BY RID/ADR.

IMO: NOT REGULATED BY IMO.

IATA: NOT REGULATED BY IATA.

15. REGULATORY INFORMATION

US OSHA HAZARD COMMUNICATION STANDARD: Product assessed in accordance with OSHA 29 CFR 1910.1200 and determined to be hazardous.

EU Labeling: Product is not dangerous as defined by the European Union Dangerous Substances/Preparations Directives.

Symbol: Not applicable.

Risk Phrase(s): Not applicable.

Safety Phrase(s): S24-62.

Avoid contact with skin. If swallowed, do not induce vomiting: seek medical advice immediately and show this container or label.

Contains: Low Viscosity Oil.

Governmental Inventory Status: All components comply with TSCA, EINECS/ELINCS, AICS, METI, and DSL.

U.S. Superfund Amendments and Reauthorization Act (SARA) Title III: This product contains no "EXTREMELY HAZARDOUS SUBSTANCES".

SARA (311/312) REPORTABLE HAZARD CATEGORIES:
CHRONIC ACUTE

This product contains no chemicals subject to the supplier notification requirements of SARA (313) toxic release program.

The following product ingredients are cited on the lists below:

CHEMICAL NAME	CAS NUMBER	LIST CITATIONS
TRIPHENYL PHOSPHATE (0.15%)	115-86-6	22

--- REGULATORY LISTS SEARCHED ---

1=ACGIH ALL	6=IARC 1	11=TSCA 4	16=CA P65 CARC	21=LA RTK
2=ACGIH A1	7=IARC 2A	12=TSCA 5a2	17=CA P65 REPRO	22=MI 293
3=ACGIH A2	8=IARC 2B	13=TSCA 5e	18=CA RTK	23=MN RTK
4=NTP CARC	9=OSHA CARC	14=TSCA 6	19=FL RTK	24=NJ RTK
5=NTP SUS	10=OSHA Z	15=TSCA 12b	20=IL RTK	25=PA RTK
				26=RI RTK

Code key: CARC=Carcinogen; SUS=Suspected Carcinogen; REPRO=Reproductive

16. OTHER INFORMATION

USE: AVIATION HYDRAULIC FLUID

NOTE: PRODUCTS OF EXXON MOBIL CORPORATION AND ITS AFFILIATED COMPANIES ARE NOT FORMULATED TO CONTAIN PCBS.

Health studies have shown that many hydrocarbons pose potential human health risks which may vary from person to person. Information provided on this MSDS reflects intended use. This product should not be used for other applications. In any case, the following advice should be considered:

INJECTION INJURY WARNING: If product is injected into or under the skin, or into any part of the body, regardless of the appearance of the wound or its size, the individual should be evaluated immediately by a physician as a surgical emergency. Even though initial symptoms from high pressure injection may be minimal or absent, early surgical treatment within the first few hours may significantly reduce the ultimate extent of injury.

Precautionary Label Text:

CONTAINS LOW VISCOSITY OIL

CAUTION!

LOW VISCOSITY MATERIAL-IF SWALLOWED, MAY BE ASPIRATED AND CAN CAUSE SERIOUS OR FATAL LUNG DAMAGE. MAY CAUSE NOSE, THROAT AND LUNG IRRITATION, DIZZINESS, NAUSEA, LOSS OF CONSCIOUSNESS.

PROLONGED, REPEATED SKIN CONTACT MAY CAUSE IRRITATION.

Keep away from heat, sparks, and flame. Avoid breathing vapor. Avoid contact with skin or clothing. Keep container closed. Use with adequate ventilation.

FIRST AID: If inhaled, remove to fresh air. If not breathing, give artificial respiration, preferably mouth-to-mouth. If breathing is difficult, give oxygen. Call a physician immediately. In case of contact, wash skin with soap and water. Remove contaminated clothing. Call a physician if irritation persists. Wash or dispose of contaminated clothing. If swallowed, seek immediate medical attention. Do not induce vomiting. Only induce vomiting at the instruction of a physician.

For industrial use only. Not intended or suitable for use in or around a household or dwelling.

Empty container may contain product residue, including flammable or explosive vapors. Do not cut, puncture, or weld on or near container. All label warnings and precautions must be observed until container has been thoroughly cleaned or destroyed.

Refer to product Material Safety Data Bulletin for further safety and health information.

For Internal Use Only: MHC: 1* 1* NE 1* 1*, MPPEC: C, TRN: 490110-00,
ELIS: 400275, CMCS97: 970584, REQ: MIAMI, SAFE USE: C
EHS Approval Date: 12AUG2003

Information given herein is offered in good faith as accurate, but without guarantee. Conditions of use and suitability of the product for particular uses are beyond our control; all risks of use of the product are therefore assumed by the user and WE EXPRESSLY DISCLAIM ALL WARRANTIES OF EVERY KIND AND NATURE, INCLUDING WARRANTIES OF MERCHANTABILITY AND FITNESS FOR A PARTICULAR PURPOSE IN RESPECT TO THE USE OR SUITABILITY OF THE PRODUCT. Nothing is intended as a recommendation for uses which infringe valid patents or as extending license under valid patents. Appropriate warnings and safe handling procedures should be provided to handlers and users. Alteration of this document is strictly prohibited. Except to the extent required by law, republication or retransmission of this document, in whole or in part, is not permitted. Exxon Mobil Corporation and its affiliated companies assume no responsibility for accuracy of information unless the document is the most current available from an official ExxonMobil distribution system. Exxon Mobil Corporation and its affiliated companies neither represent nor warrant that the format, content or product formulas contained in this document comply with the laws of any other country except the United States of America.

Prepared by: ExxonMobil Oil Corporation
Environmental Health and Safety Department, Clinton, USA