

Models: 02-0526-0110

5 TON

SINGLE STAGE JACK

February 2000

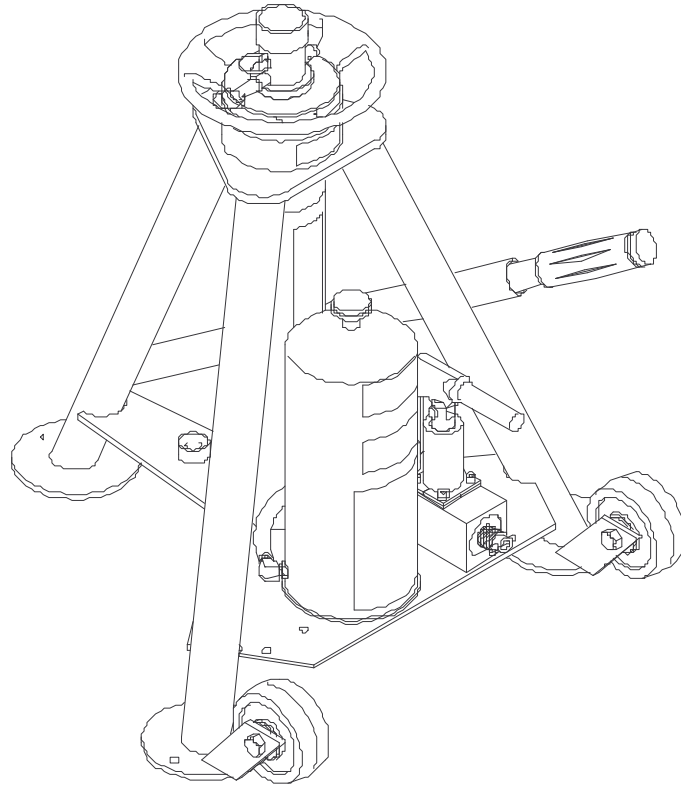

TABLE OF CONTENTS

	<u>PAGE</u>
1.0 Description.....	1
2.0 Usage	1
3.0 Specifications.....	1
4.0 Assembly Instructions.....	1
4.1 General Information.....	1
4.2 Pre-Use Checks.....	1
5.0 Operating Instructions.....	2
6.0 Maintenance-General.....	3
6.1 Servicing Jack.....	3-4
6.2 Removing and Servicing Pump	4
6.3 Jack Function Load Test	4
7.0 Trouble Shooting	5
Parts List	6-7
Parts Illustrations	8-9
APPENDIX: HC-1753-01 1950 PSI Hand Pump Parts List	

Model: 02-0526-0110
5 TON SINGLE STAGE JACK

1.0 DESCRIPTION

The Tronair Single Stage Jack incorporates the following quality features:

- Steel Construction
- Mechanical ram locknut prevents lowering of jack under load
- Mechanical extension
- Single speed, manually operated pump with pressure relief
- Uses standard MIL-H-5606 hydraulic fluid.

2.0 USAGE

The purpose of the jack is to lift the aircraft for maintenance. See Specifications for capacity of jack.

3.0 SPECIFICATIONS

Capacity:	10,000 lbs.	Hydraulic Extension:	16 inches
Closed Height:	26 inches	Fully Extended:	50 inches
Mechanical Extension:	8 inches	Weight:	100 lbs.

4.0 ASSEMBLY INSTRUCTIONS

4.1 GENERAL INFORMATION

This product should be assembled and/or repaired using good workmanship practices and proper tools. Bolts and elastic stopnuts should be tightened to a torque not to exceed industry standards for Grade '5' bolts. The d-24 bolts should be tightened to 35 ft-lbs.

All replacement parts must be the same as or equal to the original parts supplied.

4.2 PRE-USE CHECKS

Refer to the Illustrated Parts Breakdown to identify and assure that all parts are present.

- Generally check over unit to assure the tightness of all nuts, bolts and fittings.
- With rams completely collapsed, check hydraulic fluid level: correct level is one and one-half inch (1¹/₂") below vent, with the hydraulic ram fully retracted.

Replenish with MIL-H-5606 fluid as required.

Model: 02-0526-0110
5 TON SINGLE STAGE JACK

5.0 OPERATING INSTRUCTIONS

The user should be familiar with the following statements prior to using the jack.

CAUTION

1. Never put hands between aircraft and jack pad. Aircraft struts may hang up and allow aircraft to suddenly drop.
2. Never align jack under aircraft by pounding on jack legs. Dented legs may lead to jack collapse.
3. Always lower ram locking nut(s) as aircraft is raised. Be sure ram nut(s) is seated fully after jacking.
4. Always raise and lower jacks simultaneously so that aircraft remains level.
5. Always use a tail or nose stand for additional stability.

5.1 JACK INSTRUCTIONS

To Raise Aircraft:

1. Place jack on a hard level surface.
2. Raise mechanical extension as close to aircraft jack pad as possible.
3. Close pump release valve and operate pump.
4. Lower ram locknuts as aircraft is raised.

To Lower Aircraft:

1. Lower all jacks simultaneously.
2. If ram locking nut(s) is tight, raise jack slightly to release nut(s).
3. Loosen pump release valve slightly to slowly lower aircraft. Raise locking nut(s), as jack ram(s) lower.

NOTE: When using the jack during a washing or cleaning operation, the jack should be completely covered to protect it from cleaning solution, dirt and foreign matter that might get on or between the ram and cylinder causing damage to the seals and O-rings.

Model: 02-0526-0110
5 TON SINGLE STAGE JACK

6.0 MAINTENANCE

GENERAL

- The jack should be stored with some type of cover to protect the jack from liquids (such as Skydrol or cleaning solutions) and other foreign matter that might get on or between ram and cylinder which will damage seals and O-rings.
- All maintenance and/or repair work should be done using good workmanship practices and proper tools. The work area should be clean and free of dirt.
- When O-rings and backup rings are removed, every effort should be made to avoid the contact of tools with the critical surfaces of parts. Surface deformities could cause degradation of seals and failure.
- It is good practice to replace both O-rings and backup rings once removed. Cut and damaged rings normally result in fluid leakage.
- If the cylinder bore is found to be rusty, it may be honed to a maximum diameter of 2.629 inches and a surface finish of 16 micro inches. If the pitting in the bore cannot be removed by this process, the jack cylinder must be replaced before the jack can be returned to service.
- At this time, flush old hydraulic fluid and dirt from overall system and replenish with new, clean hydraulic fluid.

6.1 SERVICING JACK

90-Day Routine Maintenance

If jack is not being used on a regular basis, every 90 days the jack should be fully extended and retracted to exercise the seals and to prevent rust build up on the cylinder I.D. While ram is extended, clean the threads and spray with DoALL RPM, LPS, or equivalent that is water repellent and will not harm BUNA "N" O-rings.

To Disassemble Jack For Seal Replacement:

1. Remove mounting plate (Item 29) by unscrewing three (3) socket head cap screws (Item 23).
2. Raise ram assembly (Item 25) to the point where it can be lifted from the jack cylinder.

6.0 Maintenance/Servicing Jack continued on following page.

Model: 02-0526-0110
5 TON SINGLE STAGE JACK

6.0 MAINTENANCE

6.1 SERVICING JACK

To Reassemble Jack:

1. Re-assemble in reverse order of above.
2. Spray inside diameter of cylinder and outside diameter of ram (Items 1 and 25) with DoALL RPM, LPS, or equivalent water repellent that will not harm the BUNA "N" O-rings to protect surfaces from rusting when not in use.

NOTE: To minimize air entrapment under the rams, raise the oil level in the cylinder to chamfer of the cylinder prior to ram insertion.

6.2 REMOVING AND SERVICING PUMP

NOTE: If pump is found to be faulty, call the factory for replacement or replace seals as follows:

1. Review illustrated parts breakdown - Pump. (HC-1753-01)
2. Clamp suction (push on) hose and remove hose from pump.
3. Uncouple output hose from pump.
4. Remove two (2) pump mounting bolts. Remove pump.
5. Remove clevis pin assembly.
6. Remove four (4) socket head cap screws.
7. Remove flanges.
8. Remove tube assembly.
9. Replace O-rings and backup ring. (See pump parts list for kits available).
10. Re-assemble in reverse order.

6.3 JACK FUNCTION LOAD TEST

If function load testing of this jack is required:

1. Take all necessary precautions to prevent injury.
2. Always jack against a load and never against the jack itself.
3. Do not exceed a test load equal to the jack rated capacity plus 10%.

Model: 02-0526-0110
5 TON SINGLE STAGE JACK

7.0 TROUBLE SHOOTING

RAM WILL NOT RISE OR RISES ERRATICALLY

PROBABLE CAUSE	CORRECTIVE ACTION
High pressure leaks (at joint, plugs or tubing)	Re-tighten or repair
Leaky discharge check valve	Pump rapidly to dislodge or repair pump
Leaky ram O-ring packing	Replace packing
Leaky release valve	Tighten release valve
Leaky pump o-ring packing	Repair pump
Lack of oil	Refill reservoir check system for leaks
Sticking inlet check valve	Pump rapidly to dislodge; repair pump
Closed air vent	Open air vent
Air in hydraulic system	Bleed system

Model: 02-0526-0110
5 TON SINGLE STAGE JACK

JACK WILL NOT LOWER

PROBABLE CAUSE	CORRECTIVE ACTION
Ram lock nut not loosened	Rotate nut as ram is lowered
Broken pump release valve	Repair pump
Bent ram	Replace suspected ram assembly

Model: 02-0526-0110
5 TON SINGLE STAGE JACK

Parts List

REPLACEMENT PARTS

ITEM	PART NUMBER	DESCRIPTION	QTY
2	H-1009-01	Assembly, Handle (Pump)	1
6	HJ-532-02	Pad, Jack	1
8	TF-1043-03*15.0	Assembly, Hose, 15" long	1
13	N-2003-06-S	Elbow, Long Male	1
20	HJ-532-01	Pad, Jack	1
21	HJ-526-02	Extension	1
22	HJ-536	Ring, Protection	1
23	G-1151-106205	Screw, Socket Head Cap, 5/16-18 x 5/8" long	3
25	HJ-522-02	Assembly, Ram (includes Seals)	1
26	G-1307-0418	Pin, 1/4" diameter x 1.8" long	1
27	G-1308-0826	Pin, 1/2" diameter x 2.6" long	1
28	H-2334	Locknut	1
29	HJ-513	Plate, Mounting	1

All other parts available in Replacement Kits only

REPLACEMENT KITS

PART NUMBER	DESCRIPTION	QTY
K-1049	Kit, Seal Replacement; consists of:	
- Item 24	HJ-512 Ring, Guide	1
- Item 30	HC-2021-01 Ring, Backup	1
- Item 31	HC-2000-331 O-ring	1
K-1061-04	Kit, Reservoir Replacement; consists of:	
- Item 14	N-2410-01 Elbow, 90° Male	1
- Item 15	TF-1047-01*09.0 Hose, 1/4 Gray x 9" long	1
- Item 16	H-1045 Breather	1
- Item 17	Z-1539-04-01 Weldment, Reservoir (includes labels)	1
- Item 18	G-1202-1050 Stopnut, 1/4-20 Elastic	3
- Item 19	G-1250-1050N Flatwasher, 1/4 Narrow	3
K-1331	Kit, Jack Weldment Replacement; consists of:	
- Item 1	Z-4819-01 Weldment, Jack (includes labels)	1
K-1901-01	Kit, Pump Replacement; consists of:	
- Item 7	N-2410-11 Elbow, 90° Male	1
- Item 9	N-2001-08-S-B Elbow, Straight Thread	1
- Item 10	HC-1753-01 Pump, Hydraulic Hand	1
- Item 11	G-1251-1070R Lockwasher, 3/8 Regular	2
- Item 12	G-1100-107010 Bolt, Hex Head, Grade 5, 3/8-16 x 1" long	2
- Item 15	TF-1047-01*09.0 Hose, 1/4 Gray x 9" long	1
K-1165	Kit, Wheel Replacement; consists of:	
- Item 3	G-1203-1095 Jamnut, 1/2-20 Elastic	2
- Item 4	U-1002 Wheel	2
- Item 5	G-1100-109526 Bolt, Hex Head, Grade 5, 1/2-20 x 2-3/4" long	2

Model: 02-0526-0110
5 TON SINGLE STAGE JACK

Parts List Illustrations

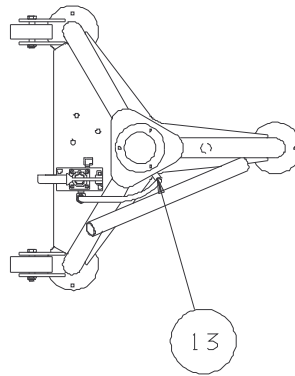
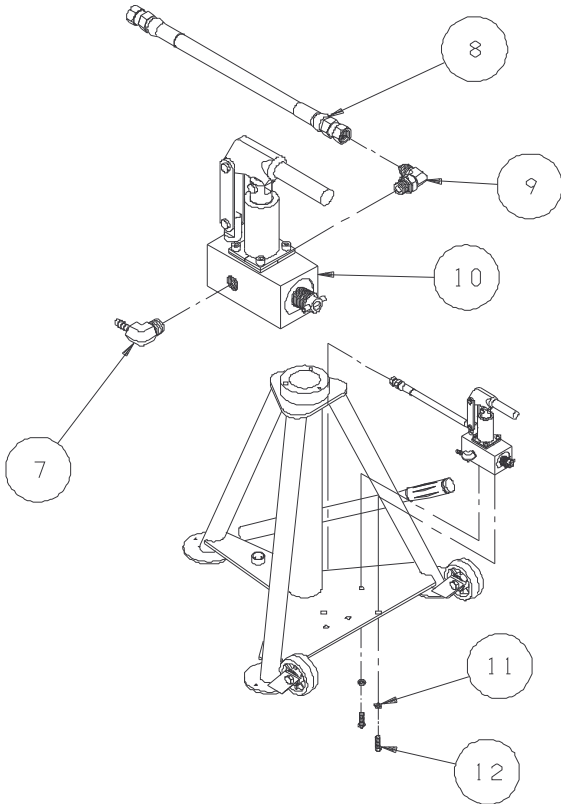
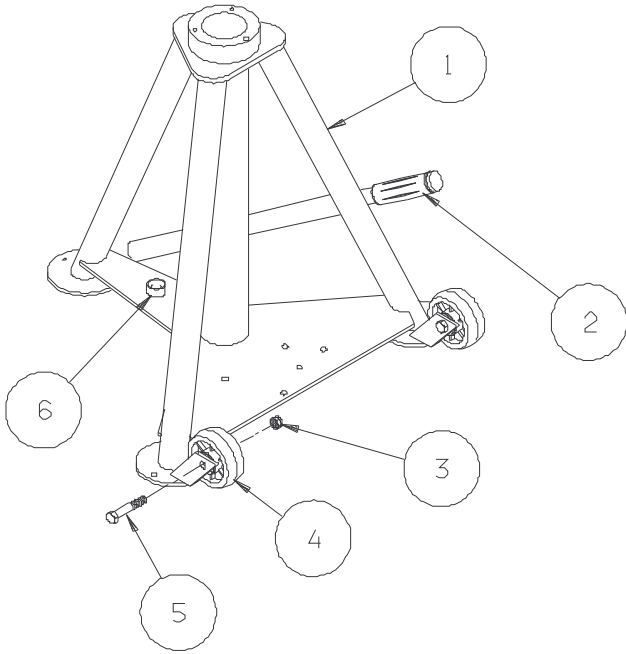

Model: 02-0526-0110
5 TON SINGLE STAGE JACK

Parts List Illustrations

