

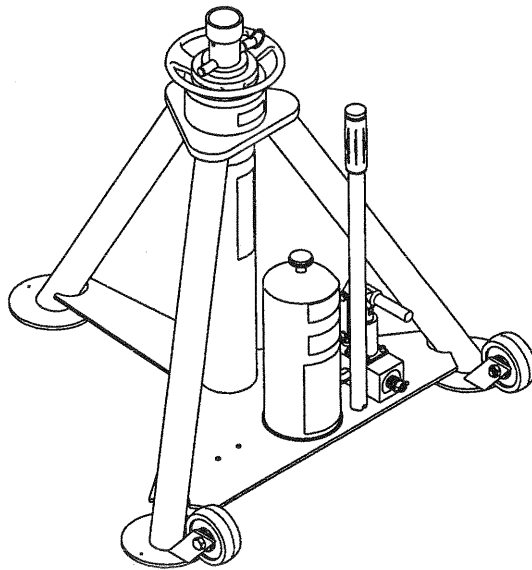

## Operation & Service Manual



**Model: 02-1036-0110**  
**10 Ton Single Stage Jack**

01/2000 – Rev. OR

**Includes Illustrated Parts Lists**

\*\* When ordering Replacement Parts/Kits, please specify Model, Color and Serial Number of your Unit.\*\*

***Tronair, Inc.***

*1740 Eber Road  
Holland, Ohio 43528-9794  
USA*

*Telephone: (419) 866-6301 • 800-426-6301*

*Fax: (419) 867-0634*

**Web Site: [www.tronair.com](http://www.tronair.com) E-mail: [mail@tronair.com](mailto:mail@tronair.com)**

Model: 02-1036-0110  
10 Ton Single Stage Jack

TABLE OF CONTENTS

	<b>PAGE</b>
1.0 DESCRIPTION.....	1
2.0 USAGE.....	1
3.0 SPECIFICATIONS.....	1
4.0 ASSEMBLY INSTRUCTIONS.....	1
4.1 GENERAL INSTRUCTION.....	1
4.2 PRE-USE CHECKS.....	1
5.0 OPERATING INSTRUCTIONS.....	2
5.1 JACK INSTRUCTIONS.....	2
6.0 MAINTENANCE.....	3
General Comments.....	3
6.1 SERVICING JACK.....	3
6.2 REMOVING AND SERVICING PUMP.....	4
6.3 JACK FUNCTION LOAD TEST.....	4
7.0 TROUBLE SHOOTING.....	5
Replacement Parts/Kits Lists & Illustrations.....	6-8
APPENDIX: HC-1752-01 2500 PSI Hand Pump Parts List	

**Model: 02-1036-0110**  
**10 Ton Single Stage Jack**

## 1.0 DESCRIPTION

The Tronair Single Stage jack incorporates the following quality features:

- Steel Construction
- Mechanical ram lock nut that prevents lowering of jack under load
- Quick action mechanical extension
- Single speed, manually operated pump with pressure relief
- Uses standard MIL-H-5606 hydraulic fluid

## 2.0 USAGE

The purpose of the jack is to lift the aircraft for maintenance. See specifications for capacity of the jack.

## 3.0 SPECIFICATIONS

- Rated Capacity: 20,000 lbs.
- Minimum Closed Height: 34 inches
- Mechanical Extension: 14 inches
- Hydraulic Extension: 20 inches
- Maximum Height Obtainable: 70 inches
- Weight: 185 lbs.
- Pressure Relief Setting: 2500+250/-0 PSIG
- BUNA 'N' Seals

## 4.0 ASSEMBLY INSTRUCTIONS

### 4.1 GENERAL INSTRUCTION

This product should be assembled and/or repaired using good workmanship practices and proper tools. Bolts and elastic stopnuts should be tightened to a torque not to exceed industry standards for Grade '5' bolts. The 3/8-24 bolts should be tightened to 35 ft-lbs.

All replacement parts must be the same as or equal to the original parts supplied.

### 4.2 PRE-USE CHECKS

Refer to the Jack Illustrated Parts Lists to identify and assure that all parts are present.

- Generally check over unit to assure the tightness of all nuts, bolts and fittings.
- With rams completely collapsed, check hydraulic fluid level; 1.5 inches below vent. Replenish with MIL-H-5606 fluid as required.

**TRONAIR**

01/2000 - Rev. OR

## 5.0 OPERATING INSTRUCTIONS

The user should be familiar with the following statements prior to using the jack(s):

### CAUTION

1. **NEVER** put hands between the aircraft and the jack pad; as after aircraft has been lowered, struts may have hung up.
2. **NEVER** align jack under aircraft by pounding on jack legs. Dented legs may lead to jack collapse.
3. **ALWAYS** lower ram locking nut(s) after jack is under load. Be sure ram nut(s) is seated fully after jacking.
4. **ALWAYS** raise and lower jacks simultaneously so that aircraft remains level.
5. **ALWAYS** use a tail or nose stand, as applicable, for additional stability.

## 5.1 JACK INSTRUCTIONS

### To Raise Aircraft:

1. Place jack on a hard, level surface.
2. Raise mechanical extension as close to aircraft jack pad as possible.
3. Close pump release valve and operate pump.
4. Lower ram locknuts as aircraft is raised.

### To Lower Aircraft:

1. Lower all jacks simultaneously.
2. If ram locking nut(s) is tight, raise jack slightly to release nut(s).
3. Loosen pump release valve slightly to slowly lower aircraft. Raise locking nut(s) as jack ram(s) lower.

**NOTE:** When using the jack during a washing or cleaning operation, the jack should be completely covered to protect it from cleaning solution, dirt and/or foreign matter which might get on or between the ram and cylinder causing damage to the seals and O-rings.

**Model: 02 -1036-0110**  
**10 Ton Single Stage Jack**

## 6.0 MAINTENANCE

### GENERAL

- All maintenance and/or repair work should be done using good workmanship practices and proper tools.
- The work area should be clean and free of dirt.
- When O-rings and backup rings are removed, every effort should be made to avoid the contact of tools with the critical surfaces of parts. Surface deformities could cause degradation of seals and failure.
- It is good practice to replace both O-rings and backup rings once removed. Cut and damaged O-rings normally result in fluid leakage.
- If cylinder bore is found to be rusty, it may be honed to a maximum diameter of 3.257 inches and a surface finish of 16 micro inches. If pitting in the bore cannot be removed by this process, the jack cylinder must be replaced before the jack can be returned to service.
- At this time, flush old hydraulic fluid and dirt from overall system and replenish with new, clean hydraulic fluid.

### 90-Day Routine Maintenance

If jack is not being used on a regular basis, every 90 days the jack should be fully extended and retracted to exercise the seals and to prevent rust build up on the cylinder I.D. While ram is extended, clean the threads and spray with DoALL RPM, LPS, or equivalent that is water repellent and will not harm BUNA "N" O-rings.

### 6.1 SERVICING JACK

#### **To Disassemble Jack:**

1. Remove mounting plate (Item 22) by unscrewing three (3) socket head cap screws (Item 21).
2. Raise ram assembly (Item 24) to the point where it can be lifted from the jack cylinder.

#### **To Reassemble Jack:**

1. Re-assemble in reverse order of above.
2. Spray inside diameter of cylinder and outside diameter of ram (Items 1 & 24) with DoALL RPM, LPS, or equivalent that is water repellent and will not harm BUNA "N" O-rings to protect surfaces from rusting when not in use.

**NOTE: To minimize air entrapment under the ram, raise the oil level in the cylinder to chamfer of the cylinder prior to ram insertion.**

*6.0 Maintenance continued on following page.*

Model: 02-1036-0110  
10 Ton Single Stage Jack

6.0 MAINTENANCE

6.2 REMOVING AND SERVICING PUMP

**NOTE:** If pump is found faulty, call the factory for replacement or replace seals as follows:

1. Review Pump Illustrated Parts List - Appendix: HC-1752-01.
2. Clamp suction (push on) hose and remove hose from pump.
3. Uncouple fitting of hydraulic hose from pump.
4. Remove pump from jack.
5. Remove cotter pin (Item 18) from clevis pin.
6. Remove four (4) socket head cap screws.
7. Remove flanges.
8. Remove tube assembly (Item 16).
9. Replace O-rings and backup ring. (See Appendix I: HC-1752-01 Pump Parts List for kits available).
10. Re-assemble in reverse order.

6.3 JACK FUNCTION LOAD TEST

**NOTE:** If function load testing is required:

1. Take all necessary precautions to prevent injury.
2. Always jack against a load and **never** against the jack itself.
3. Do not exceed a test load equal to the jack rated capacity plus 10%.

**Model: 02 -1036-0110  
10 Ton Single Stage Jack**

**7.0 TROUBLE SHOOTING**

<b>TROUBLE</b>	<b>PROBABLE CAUSE</b>	<b>REMEDY</b>
<b>Ram will not rise or rises erratically:</b>	High pressure leaks (at joint, plugs, or tubing)	Re-tighten or repair
	Leaky discharge check valve	Pump rapidly to dislodge; or repair pump
	Leaky ram O-ring packing	Replace packing
	Leaky release valve	Tighten release valve
	Leaky pump O-ring packing	Repair pump
	Lack of oil	Refill reservoir; check system for leaks
	Sticking inlet check valve	Pump rapidly to dislodge; or repair pump
	Closed air vent	Open air vent
	Air under ram	Bleed system
<b>Jack will not lower:</b>	Ram locknut not in right place	Rotate nut to top of ram
	Broken pump release valve	Repair pump
	Bent ram	Replace suspected ram assembly

**Model: 02 -1036-0110  
10 Ton Single Stage Jack**

**Parts List**

Reference Parts List Illustrations on Pages 7 & 8.

**REPLACEMENT PARTS**

<b>ITEM</b>	<b>PART NUMBER</b>	<b>DESCRIPTION</b>	<b>QTY</b>
2	H-1009-01	Handle, Hydraulic Pump	1
7	TF-1043-03*15.0	Assembly, Hose	1
12	N-2004-06-S	Elbow, Extra Long 90° Male	1
19	HJ-553	Ring, Ram Protection	1
20	H-2331	Locknut	1
21	G-1151-106205	Screw, Hex Socket Head Cap, 5/16-18 x 5/8" long	3
22	HJ-556	Plate, Mounting	1
24	HJ-586-02	Assembly, Ram	1
25	TR-1505	Stop, Jack	1
26	HJ-557	Pad, Jack	1
27	G-1300-25200	Pin, 1/4" diameter x 2" long, Roll	1
28	HJ-225-03	Shaft, Extension	1
29	G-1318-1033	Pin, 5/8" diameter x 3.3" long, Model "D"	1

*All other parts available in Replacement Kits only.*

**REPLACEMENT KITS**

<b>PART NUMBER</b>	<b>DESCRIPTION</b>	<b>QTY</b>
<b>K-1050</b>	<b>Kit, Ram Seal Replacement;</b> consists of:	
- Item 23	HJ-554 Ring, Guide	1
- Item 30	HC-2020-336 Ring, Backup	1
- Item 31	HC-2000-336 O-ring	1
<b>K-1061-02</b>	<b>Kit, Reservoir Replacement;</b> consists of:	
- Item 13	N-2410-01 Elbow, 90 Degree Male	1
- Item 14	TF-1047-01*09.0 Hose, Push-on	1
- Item 15	H-1045 Breather	1
- Item 16	Z-1539-02-01 Weldment, Reservoir (with Labels)	1
- Item 17	G-1202-1050 Stopnut, 1/4-20 Elastic	3
- Item 18	G-1250-1050N Flatwasher, 1/4 Narrow	3
<b>K-1165</b>	<b>Kit, Caster Replacement;</b> consists of:	
- Item 3	G-1203-1095 Jamnut, 1/2-20 Elastic	1
- Item 4	U-1002 Wheel	1
- Item 5	G-1100-109526 Bolt, Hex Head, Grade 5, 1/2-20 x 2-3/4" long	1
<b>K-1322</b>	<b>Kit, Replacement Jack Weldment;</b> consists of:	
- Item 1	Z-4741-01 Weldment, Jack with Labels	1
<b>K-1987</b>	<b>Kit, Pump Replacement;</b> consists of:	
- Item 6	N-2410-11 Elbow, 90° Male	1
- Item 8	N-2001-08-S-B Elbow, 90° Male	1
- Item 9	HC-1752-01 Pump, Hydraulic Hand	1
- Item 10	G-1251-1070R Lockwasher, 3/8 Regular	2
- Item 11	G-1100-107010 Bolt, Hex Head, Grade 5, 3/8-16 x 1" long	2
- Item 14	TF-1047-01*12.0 Hose, Push-on	1

**TRONAIR**

01/2000 - Rev. OR



Model: 02-1036-0110  
10 Ton Single Stage Jack

Parts List Illustrations

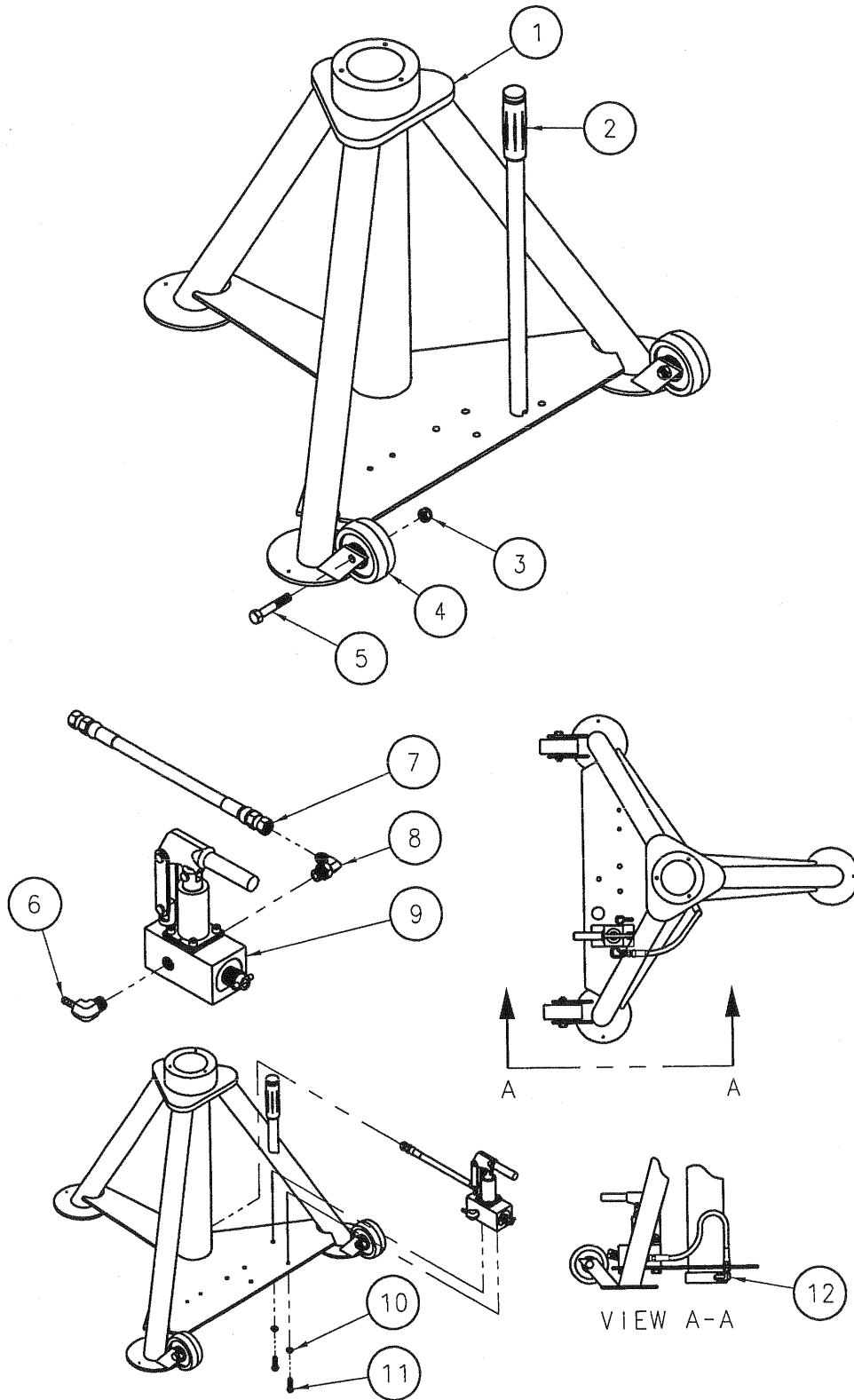

**TRONAIR**

01/2000 - Rev. OR

Model: 02-1036-0110  
10 Ton Single Stage Jack

Parts List Illustrations

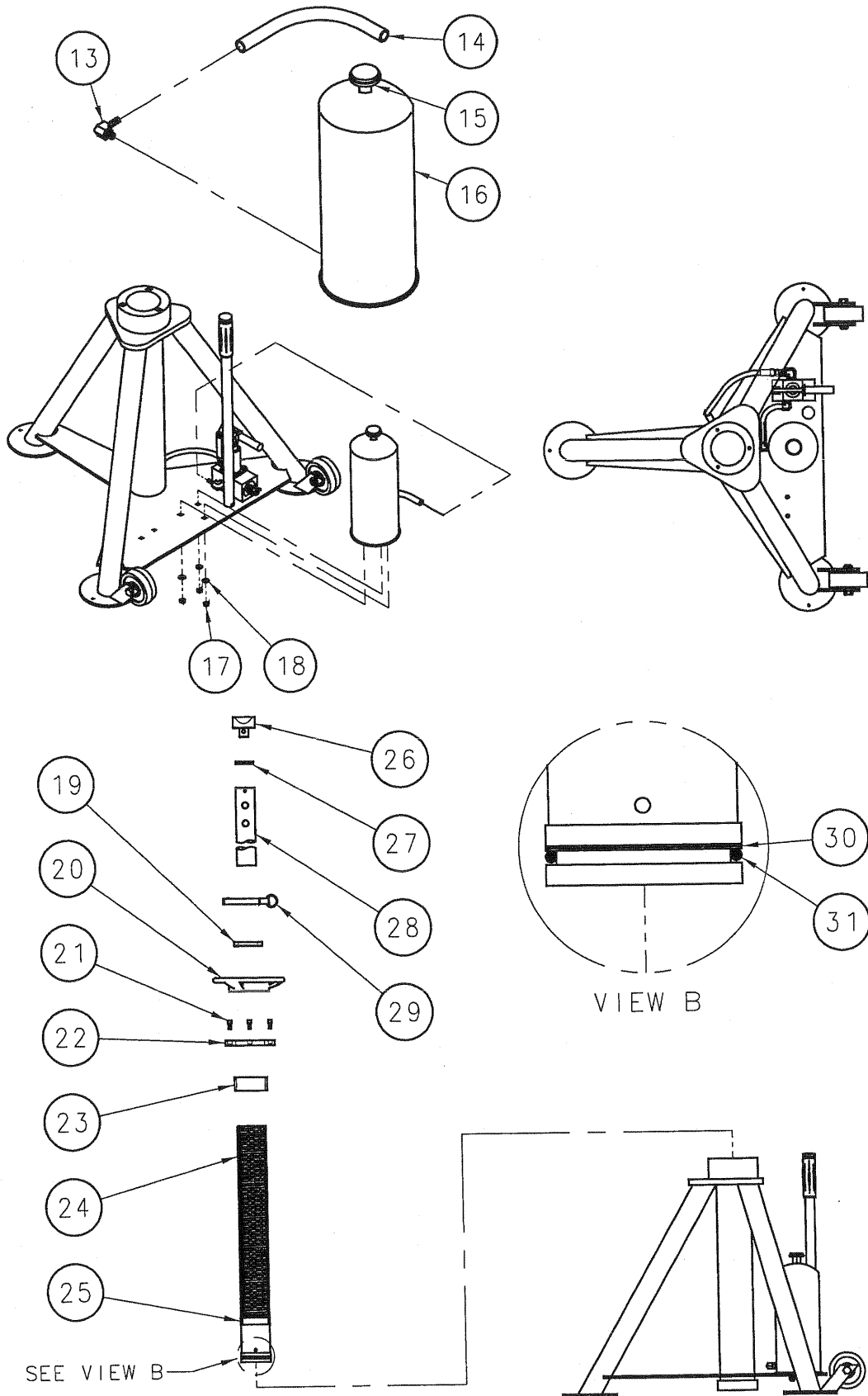



**APPENDIX I**  
**Model: HC-1752-01**  
**2500 PSI Hand Pump**

\*\*\*

**Parts List**  
**With**  
**Illustrations**

02/1998 – Rev. 01

***Tronair, Inc.***

*1740 Eber Road  
Holland, Ohio 43528-9794  
USA*

*Telephone: (419) 866-6301 • 800-426-6301*

*Fax: (419) 867-0634*

**Web Site: [www.tronair.com](http://www.tronair.com) E-mail: [mail@tronair.com](mailto:mail@tronair.com)**

**HC-1752-01  
2500 PSI Hand Pump**

**Parts List**

- **This pump is compatible with MIL-H-5606 / MIL-H-83282 Hydraulic Fluids only.**

Reference Parts List Illustration on Page 3.

**REPLACEMENT PARTS**

<b>ITEM</b>	<b>PART NUMBER</b>	<b>DESCRIPTION</b>	<b>QTY</b>
3	5M1-000-001	Body, Pump	1
12	506-000	Half, Flange	4
25	518-000	Screw, Socket Head Cap	4
Not Shown	H-1009-01	Handle	1

**REPLACEMENT KITS**

<b>PART NUMBER</b>	<b>DESCRIPTION</b>	<b>QTY</b>
<b>K-1001</b>	<b>Kit, Seal Replacement;</b> consists of:	
- Item 4	O-ring, Release Screw	1
- Item 6	O-ring, Outlet Check	1
- Item 11	O-ring, Valve Body	1
- Item 21	Wiper, Rod	1
- Item 22	Ring, Backup	1
- Item 23	O-ring, Piston	1
- Item 27	O-ring, Tube Seal	1
◆ Not Shown	O-ring, Inlet Check	1
◆ Not Shown	O-ring, Guide Shoe	2
◆ Not Shown	Shoe, Piston Guide	1
<b>K-1068</b>	<b>Kit, Linkage Replacement;</b> consists of:	
- Item 13	Pivot	1
- Item 14	Assembly, Linkage Pin	2
- Item 17	Strap	2
- Item 18	Assembly, Clevis Pin	1
- Item 19	Bracket, Pump Handle	1
<b>K-1069</b>	<b>Kit, Internal Parts Replacement;</b> consists of:	
◆ Not Shown	Ball, Release	1
- Item 7	Spring, Inlet Check	1
- Item 8	Spring, Outlet Check	1
- Item 9	Ball, Outlet Check	1
- Item 10	Ball, Inlet Check	1

- ◆ **Although this item is listed in its particular kit, it is not used on HC-1752-01 pump. These items may be discarded.**

**HC-1752-01  
2500 PSI Hand Pump**

**Parts List**

Reference Parts List Illustration on Page 3.

**REPLACEMENT KITS**

<b>PART NUMBER</b>	<b>DESCRIPTION</b>	<b>QTY</b>
<b>K-1778</b>	<b>Kit, Piston/Cylinder Replacement; consists of:</b>	
- Item 15	Piston	1
- Item 16	Tube	1
- Item 20	Retainer, Wiper	1
- Item 24	Assembly, Valve Body (Includes Items 7, 10, 24, 26)	1
<b>K-1906</b>	<b>Kit, Piston/Seal Replacement; consists of:</b>	
- Item 15	Piston	1
- Item 22	Ring, Backup	1
- Item 23	O-ring, Piston	1
<b>K-2783</b>	<b>Kit, Release Screw Replacement; consists of:</b>	
- Item 2	Screw, Release	1
- Item 30	Retainer, Screw	1

**NOTE: Entire pump assembly can be purchased as a kit. See Hydraulic Jack Parts list.**

HC-1752-01  
2500 PSI Hand Pump

Parts List Illustration

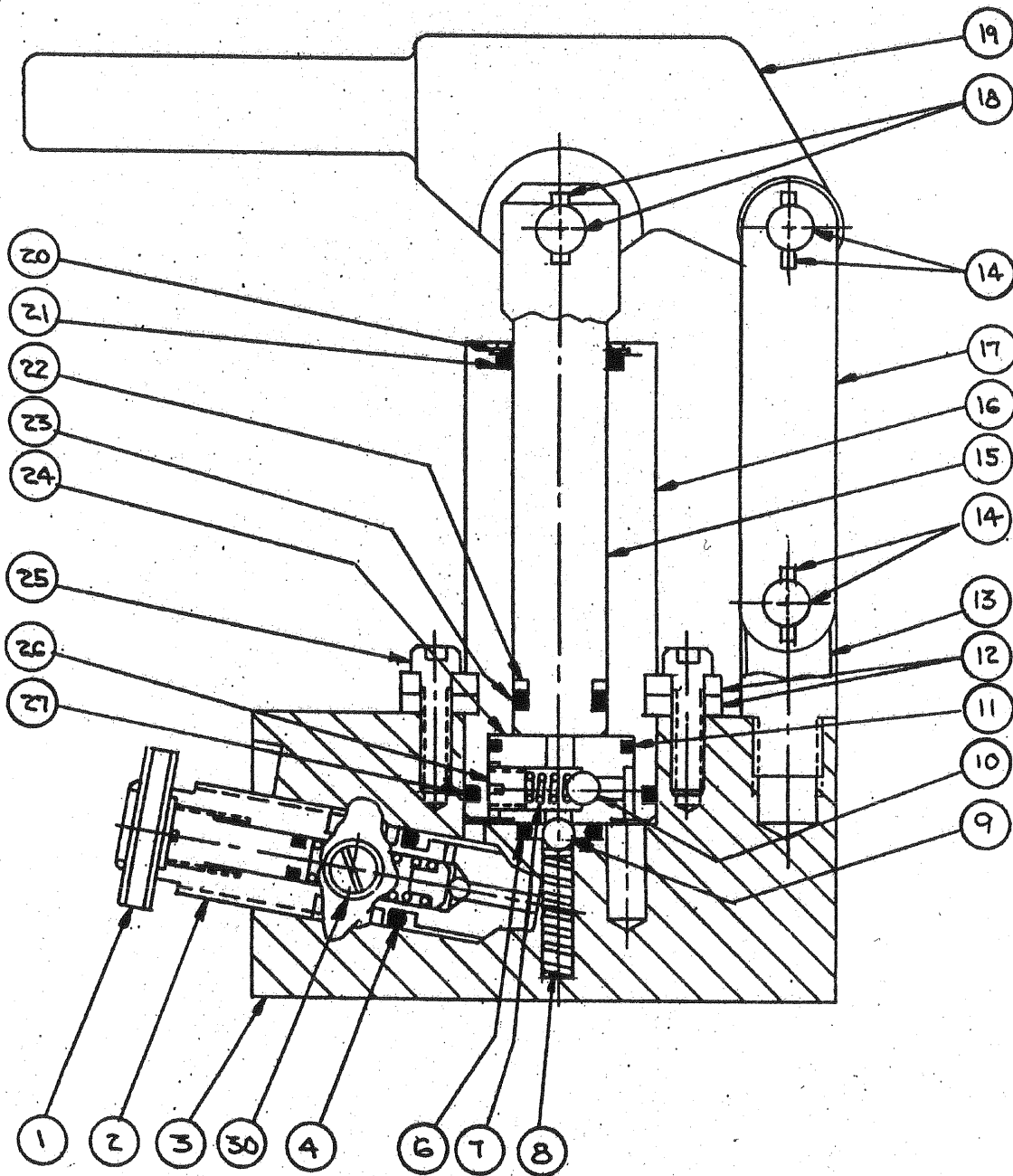

**WARNING!**

Item 2 is a preset relief valve. Do not disassemble this valve.  
Replacement parts are available as a preset relief valve assembly.

**TRONAIR**

02/1998 - Rev. 01