

## 12 Ton (10.8 Metric Ton) Axle Jack

### Models:

02-7833C0110, 02-7846C0110, 02-7852C0100,  
02-7861C0100, 02-7861-9100, 02-7863C0100,  
02-7902C0100, 02-7918C0100, 02-7918C9100



05/2021 – Rev. 03

REVISION	DATE	TEXT AFFECTED
01	07/2008	Original release
02	11/2017	Major revision
03	05/2021	Major revision



**TABLE OF CONTENTS**

**PAGE**

**1.0 PRODUCT INFORMATION ..... 1**

1.1 DESCRIPTION..... 1

1.2 MODEL & SERIAL NUMBER..... 1

1.3 MANUFACTURER ..... 1

1.4 USAGE ..... 1

1.5 SPECIFICATIONS ..... 1

**2.0 SAFETY INFORMATION ..... 2**

2.1 USAGE AND SAFETY INFORMATION ..... 2

**3.0 ASSEMBLY INSTRUCTIONS..... 2**

3.1 GENERAL INFORMATION ..... 2

3.2 PRE-USE CHECKS ..... 2

**4.0 TRAINING ..... 2**

4.1 TRAINING REQUIREMENTS ..... 2

4.2 TRAINING PROGRAM ..... 2

4.3 OPERATOR TRAINING ..... 2

**5.0 OPERATING INSTRUCTIONS ..... 3**

5.1 TO RAISE GEAR ..... 3

5.2 TO RAISE NOSE GEAR – 02-7833C0110 ONLY ..... 3

5.3 TO RAISE MAIN GEAR – 02-7833C0110 ONLY ..... 4

5.4 TO LOWER GEAR ..... 4

**6.0 TROUBLE SHOOTING ..... 5**

**7.0 MAINTENANCE..... 6**

7.1 GENERAL ..... 6

7.2 SERVICING JACK ..... 6

7.3 JACK FUNCTION LOAD TEST..... 6

**8.0 PROVISION OF SPARES..... 6**

8.1 SPARE PARTS ..... 6

8.2 PARTS LISTS & ILLUSTRATIONS..... 6

**9.0 IN-SERVICE SUPPORT..... 6**

**10.0 GUARANTEES/LIMITATION OF LIABILITY ..... 7**

**11.0 APPENDICES ..... 7**

This product can not be modified without the written approval of Tronair, Inc. Any modifications done without written approval voids all warranties and releases Tronair, Inc., its suppliers, distributors, employees, or financial institutions from any liability from consequences that may occur. Only Tronair OEM replacement parts shall be used.

**1.0 PRODUCT INFORMATION**

**1.1 DESCRIPTION**

These Tronair Hydraulic Axle Jacks incorporate the following quality features:

- Steel construction
- Four-stage ram
- Hi/Low, manually operated pump
- Uses standard MIL-PRF-5606 hydraulic fluid

**1.2 MODEL & SERIAL NUMBER**

Reference nameplate on unit

**1.3 MANUFACTURER**

**TRONAIR, Inc.**  
1 Air Cargo Pkwy East  
Swanton, Ohio 43558 USA

Telephone: (419) 866-6301 or 800-426-6301  
Fax: (419) 867-0634  
E-mail: sales@tronair.com  
Website: www.tronair.com

**1.4 USAGE**

The purpose of this jack is to lift aircraft at the landing gear for maintenance. It has a maximum capacity of 12 tons (10.8 metric tons).

**1.5 SPECIFICATIONS**

- Vertical capacity ..... 24,000 lbs (10.8 Metric Tons)
- BUNA 'N' Seals

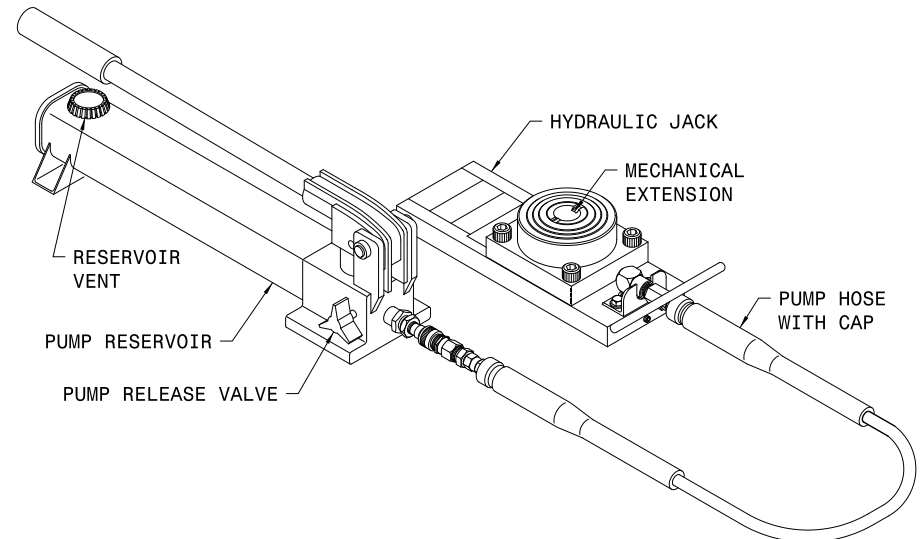

Model	Closed in (cm)	Hydraulic in (cm)	Mechanical in (cm)	Extended in (cm)	Spacer Blocks in (cm)			Weight lb (kg)
02-7833C0110	3 (7.6)	--	--	8-5/16 (21.1)	½ (1.3)	¾ (1.9)	1-1/2 (3.8)	60.5 (27.4)
02-7846C0100	3-3/4 (9.5)	--	--	11-5/8 (29.5)	--	--	--	31.9 (14.5)
02-7852C0100	3 (7.6)	5-5/16 (13.5)	--	8-5/16 (21.1)	--	--	1-1/2 (3.8)	55.8 (25.3)
02-7861C0100	3-3/4 (9.5)	7-13/16 (19.8)	1-1/16 (2.7)	12-5/8 (32.1)	--	--	--	44.9 (20.4)
02-7861-9100	3-3/4 (9.5)	7-13/16 (19.8)	1-1/16 (2.7)	12-5/8 (32.1)	--	--	--	44.9 (20.4)
02-7863C0100	3-3/16 (8.1)	3-3/8 (8.6)	1-7/16 (3.7) 2-3/4 (7)	15-3/8 (39.1)	½ (1.3)	¾ (1.9)	--	47.6 (21.6)
02-7902C0100	3-3/16 (8.1)	6-3/8 (16.2)	--	--	½ (1.3)	¾ (1.9)	--	47.6 (21.6)
02-7918C0100	3-3/4 (9.5)	7-13/16 (19.8)	1-1/16 (2.7)	12-5/8 (32.1)	--	¾ (1.9)	--	44.93(20.4)
02-7918C9100	3-3/4 (9.5)	7-13/16 (19.8)	1-1/16 (2.7)	12-5/8 (32.1)	--	¾ (1.9)	--	44.9 (20.4)

## 2.0 SAFETY INFORMATION

### 2.1 USAGE AND SAFETY INFORMATION

To insure safe operations please read the following statements and understand their meaning. Also refer to your equipment manufacturer's manual for other important safety information. This manual contains safety precautions which are explained below. Please read carefully.



**WARNING!** — Warning is used to indicate the presence of a hazard that **can cause severe personal injury, death, or substantial property damage** if the warning notice is ignored.

**CAUTION!** — Caution is used to indicate the presence of a hazard that **will or can cause minor personal injury or property damage** if the caution notice is ignored.

## 3.0 ASSEMBLY INSTRUCTIONS

### 3.1 GENERAL INFORMATION

This product should be assembled and/or repaired using good workmanship practices and proper tools.

All replacement parts must be the same as or equal to the original parts supplied.

### 3.2 PRE-USE CHECKS

Refer to the Illustrated Parts List to identify and ensure that all parts are present.

- Generally check over unit to assure the tightness of all nuts, bolts and screws.
- With rams completely collapsed, check to see if the hydraulic pump reservoir is filled with hydraulic fluid. Replenish with MIL-PRF-5606 fluid as required.

## 4.0 TRAINING

### 4.1 TRAINING REQUIREMENTS

The employer of the operator is responsible for providing a training program sufficient for the safe operation of the unit.

### 4.2 TRAINING PROGRAM

The employer provided operator training program should cover safety procedures concerning use of the unit in and around the intended aircraft at the intended aircraft servicing location.

### 4.3 OPERATOR TRAINING

The operator training should provide the required training for safe operation of the unit.

**NOTE: Maintenance and Trouble Shooting are to be performed by a skilled and trained technician.**

## 5.0 OPERATING INSTRUCTIONS

The user should be familiar with the following statements prior to using the jack(s).



### CAUTION!

- Never put hands between aircraft and jack pad.
- Always open reservoir vent screw before operating.

### 5.1 TO RAISE GEAR

1. Place hydraulic jack on a hard level surface.
2. Use the mechanical extension(s) and spacer blocks (if applicable) to get the ram as close as possible to the jack pad.
3. Chock aircraft tires on gear not being raised.
4. Connect pump hose.
5. Open reservoir vent screw.
6. Close pump release valve and operate pump.

### 5.2 TO RAISE NOSE GEAR – 02-7833C0110 ONLY

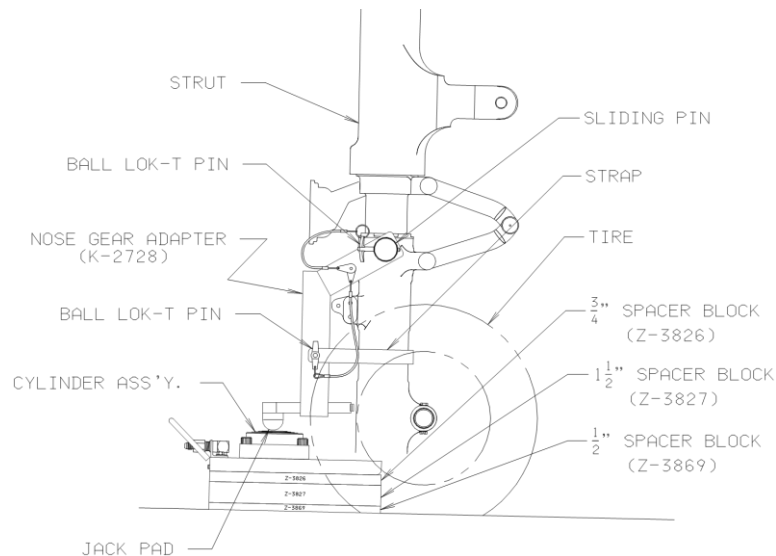

1. Attach the nose gear adapter to the strut. Place the strap around the strut and lock in place with the ball lok-T pin. Insert both sliding pins into the towing bowls on the strut. Lock sliding pins in place with the ball lok-T pins.
2. Place hydraulic jack on a hard level surface.
3. Use the spacer blocks (Z-3826, Z-3827 and Z-3869) in order to get the ram as close as possible to the jack pad.

**NOTE: The one-half inch (1/2") spacer block (Z-3869) must only be used alone or located at the floor level.**



### WARNING!

**NEVER use above the bottom spacer block.**

4. After the nose gear adapter is secured onto the strut, line up jack pad with the spherical recess in the center of the cylinder assembly.
5. Chock aircraft tires on gear not being raised.
6. Connect pump hose.
7. Open reservoir vent screw.
8. Close pump release valve and operate pump.

## 5.3 TO RAISE MAIN GEAR – 02-7833C0110 ONLY

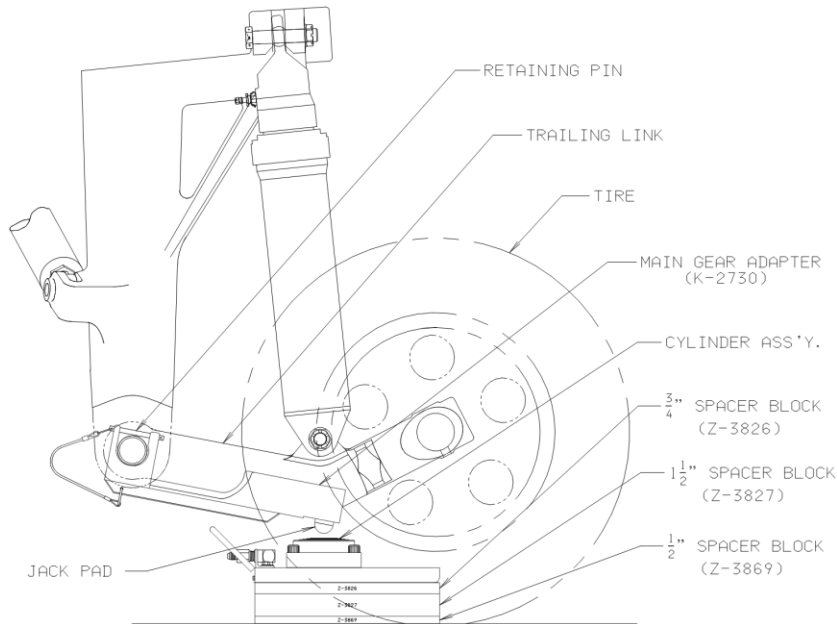

1. Attach main gear adapter to trailing link. Secure in place with both retaining pins.
2. Place hydraulic jack on a hard level surface between tires.
3. Use the spacer blocks (Z-3826, Z-3827 and Z-3869) in order to get the ram as close as possible to the jack pad.

**NOTE: The one-half inch (1/2") spacer block (Z-3869) must only be used alone or located at the floor level.**



### WARNING!

**NEVER use above the bottom spacer block.**

4. After the main gear adapter is secured on trailing link, line up jack pad with the spherical recess in the center of the cylinder assembly.
5. Chock aircraft tires on gear not being raised.
6. Connect pump hose.
7. Open reservoir vent screw.
8. Close pump release valve and operate pump.

## 5.4 TO LOWER GEAR

Slightly open pump release valve to slowly lower jack.

## 6.0 TROUBLE SHOOTING

TROUBLE	PROBABLE CAUSE	ACTION
Fluid leakage at pump piston or pump body	Damaged backup ring, o-ring, piston or pump body	Remove piston and pump body. Inspect for damage. Replace defective part(s). Replace removed o-ring and backup ring
External fluid leakage at ram(s)	Damaged o-ring, backup ring or inner cylinder wall	Remove ram(s) as a unit from cylinder. Inspect parts. Replace o-ring and defective part(s)
Jack fails to lift rated load	Release valve not closed properly	Fully tighten release valve
	Low fluid level	Fill to correct fluid level
	Pressure relief valve improperly adjusted	Adjust or replace release valve
	Leakage at inlet or outlet check ball	Inspect valve body for wear or replace valve body and check balls
	Vent screw closed	Open vent screw
Ram(s) will not support load after manual or pneumatic pump up	Leaking ram o-ring seals	Check for external leakage, if present replace defective seal and back up ring
	Leaking pressure check valve	Inspect valve body for wear or replace valve body and check balls
	Leaking pressure relief valve	Remove release valve, inspect ball and ball seat in pump block. Replace effective part(s)
Ram(s) raise and fall with each manual pump stroke	Release valve open	Fully tighten release valve
	Inlet check valve not seated or sticking	Pump rapidly to dislodge or replace valve body
	Pressure check valve not seated or sticking	Pump rapidly to dislodge or replace valve body
Jack fails to lower	Ram locknut not loosened	Raise jack ¼ inch and release locknut
	Vent screw closed	Open vent screw
	O-Ring (pinched or rolled)	Replace o-ring and back-up ring, clean up cylinder wall of debris



## 7.0 MAINTENANCE

### 7.1 GENERAL

- All maintenance and/or repair work should be done using good workmanship practices and proper tools.
- The work area should be clean and free of dirt.
- When O-rings and backup rings are removed, every effort should be made to avoid the contact of tools with the critical surfaces of parts. Surface deformities could cause degradation of seals and failure.
- It is good practice to replace all O-rings and backup rings once removed. Cut and damaged rings normally result in fluid leakage.
- At this time flush old hydraulic fluid and dirt from overall system and replenish with new, clean hydraulic fluid
- No modifications shall be carried out which adversely affect the compliance of the jack with draft standard 2006/42/EC.

### 7.2 SERVICING JACK

#### To Disassemble Jack:

1. Collapse jack rams.
2. Remove cap screws (pg 10, Item 22) surrounding jack cylinder and retaining ring (pg 10, Item 21).
3. Lift cylinder from axle jack base weldment (pg 10, Items 15 thru 20). Operate jack hand pump to help remove cylinder.
  - a. Separate rams by removing internal rings (pg 11, Items 4, 5, & 6).
  - b. Replace all seals including internal rings.

#### To Reassemble Jack:

1. Re-assemble in reverse order of above.
2. Torque each cap screw (pg 10, Item 22) to 50 ft-lb, using standard cross torque procedure.

#### To Bleed Jack of Air:

1. Open reservoir vent screw on hand pump.
2. Pump unit to fully extended position.
3. Turn jack upside down.
4. Push jack back to fully collapsed position.

### 7.3 JACK FUNCTION LOAD TEST

1. Take all necessary precautions to prevent injury.
2. Always jack against a load and never against the jack itself.
3. Apply a test load equal to the jack rated capacity plus 10%. **Note: Do not exceed this load.**
4. Capacity test annually

## 8.0 PROVISION OF SPARES

### 8.1 SPARE PARTS

Spare parts may be obtained from the manufacturer:

**TRONAIR**, Inc.  
1 Air Cargo Pkwy East  
Swanton, Ohio 43558 USA

Telephone: (419) 866-6301 or 800-426-6301  
Fax: (419) 867-0634  
E-mail: sales@tronair.com  
Website: www.tronair.com

### 8.2 PARTS LISTS & ILLUSTRATIONS

Reference the following page for Replacement Parts and Kits available.

## 9.0 IN-SERVICE SUPPORT

Contact Tronair for technical services and information.



## 10.0 GUARANTEES/LIMITATION OF LIABILITY

Tronair products are warranted to be free of manufacturing or material defects for a period of one year after shipment to the original customer. This is solely limited to the repair or replacement of defective components. This warranty does not cover the following items:

- a) Parts required for normal maintenance
- b) Parts covered by a component manufacturer's warranty
- c) Replacement parts have a 90-day warranty from date of shipment

If you have a problem that may require service, contact Tronair immediately. Do not attempt to repair or disassemble a product without first contacting Tronair, any action may affect warranty coverage. When you contact Tronair be prepared to provide the following information:

- a) Product Model Number
- b) Product Serial Number
- c) Description of the problem

If warranty coverage is approved, either replacement parts will be sent or the product will have to be returned to Tronair for repairs. If the product is to be returned, a Return Material Authorization (RMA) number will be issued for reference purposes on any shipping documents. Failure to obtain a RMA in advance of returning an item will result in a service fee. A decision on the extent of warranty coverage on returned products is reserved pending inspection at Tronair. Any shipments to Tronair must be shipped freight prepaid. Freight costs on shipments to customers will be paid by Tronair on any warranty claims only. Any unauthorized modification of the Tronair products or use of the Tronair products in violation of cautions and warnings in any manual (including updates) or safety bulletins published or delivered by Tronair will immediately void any warranty, express or implied.

The obligations of Tronair expressly stated herein are in lieu of all other warranties or conditions expressed or implied. **Any unauthorized modification of the Tronair products or use of the Tronair products in violations of cautions and warnings in any manual (including updates) or safety bulletins published or delivered by Tronair will immediately void any warranty, express or implied and Tronair disclaims any and all liability for injury (WITHOUT LIMITATION and including DEATH), loss or damage arising from or relating to such misuse.**

## 11.0 APPENDICES

- APPENDIX I Safety Data Sheet – MIL-PRF-5606 Hydraulic Fluid
- APPENDIX II Declaration of Conformity
- APPENDIX III Maintenance Schedule

### Parts List

When ordering replacement parts/kits, please specify model, serial number and color of your unit.

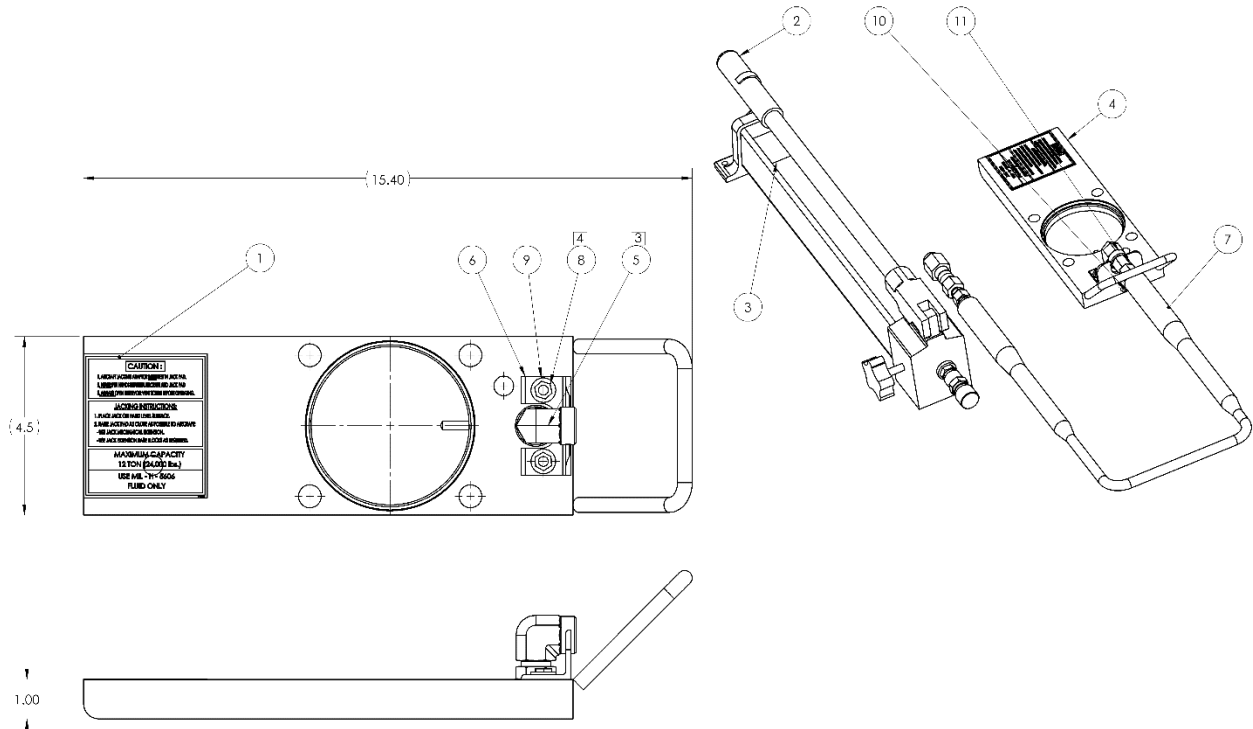

Item	Part Number	Description	Qty
1	V-1405	LABEL, AXLE JACK	1
2	Z-5684	ASSEMBLY, HAND PUMP	1
3	V-1001	LABEL, MADE IN USA	1
4	Z-3823	WELDMENT, AXLE JACK BASE	1
5	N-2228-12-S-B	ELBOW, 90° FEMALE	1
6	A-1155-01	ANGLE, HOSE SUPPORT	1
7	Z-5680	ASSEMBLY, HOSE	1
8	G-1100-105506	BOLT, H H, GR 5, 1/4-28 X 3/4 LONG	2
9	G-1250-1050N	FLATWASHER, 1/4 NARROW	2
10	N-2205-02-S	PLUG, HOLLOW HEX	1
11	HC-1551	ELBOW, SWIVEL NUT, SAE #6	1
	<b>K-3772</b>	<b>Kit, Hand Pump Replacement; consists of:</b>	
N/S	N-2203-06-S	Nipple, Pipe	1
N/S	N-2713	Nipple, Hydraulic (Male)	1
N/S	HC-2762	Hand Pump with Labels	1
	<b>K-1508</b>	<b>Kit, Hydraulic Pump Seal Replacement</b> <i>(This kit includes all soft seals, wipers, and gaskets required to reseal the pump)</i>	

**Parts List**

When ordering replacement parts/kits, please specify model, serial number and color of your unit.

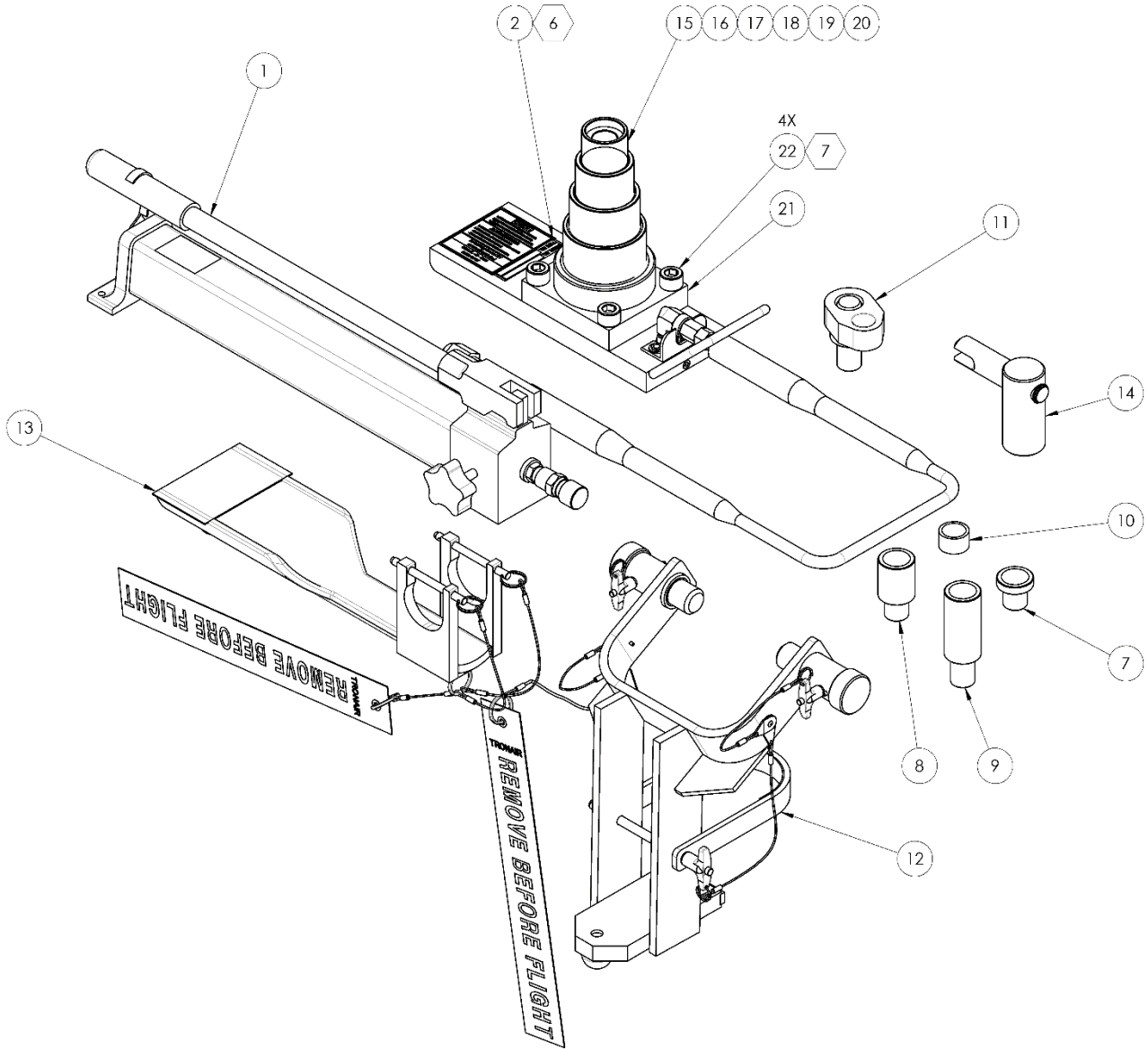

FOR MORE CLARITY ITEM NO 16, 17, 18, 19 & 20 NOT SHOWN.

### Parts List

When ordering replacement parts/kits, please specify model, serial number and color of your unit.

Item	Part Number	Description	Z-4936-Z1	Z-4936-Z2	Z-4936-Z3	Z-4936-Z4	Z-4936-Z5	Z-4936-Z6	Z-4936-Z7	Z-4936-Z8
1	Z-4936-81	BASE ASSEMBLY, 12 TON AXLE JACK	1	1	1	1	1	1	1	1
2	V-2839	LABEL, JACK TYPE/SERIAL	1	1	1	1	1	1	1	1
7	R-2012-01	PAD, JACK	1	-	-	-	-	-	-	-
8	R-2012-02	PAD, JACK	1	-	-	-	-	-	-	-
9	R-2012-03	PAD, JACK	1	-	-	-	-	-	-	-
10	R-1820	PAD, AXLE JACK	-	-	-	1	-	-	-	-
11	Z-7392	WELDMENT, ADAPTOR	-	-	-	-	-	-	-	1
12	Z-3363	ASSEMBLY, NOSE ADAPTER	-	-	-	-	-	1	1	-
13	Z-3299	ASSEMBLY, MAIN ADAPTER	-	-	-	-	-	-	1	-
14	Z-3275	ASSEMBLY, NOSE ADAPTER	-	-	-	1	-	-	-	-
15	Z-4935	ASSEMBLY, CYLINDER	1	-	-	-	-	-	-	1
16	Z-3825	ASSEMBLY, CYLINDER	-	1	-	-	-	-	1	-
17	Z-5737	ASSEMBLY, CYLINDER	-	-	1	-	-	-	-	-
18	Z-10908	ASSEMBLY, CYLINDER	-	-	-	1	-	-	-	-
19	Z-10909	ASSEMBLY, CYLINDER	-	-	-	-	1	-	-	-
20	Z-10910	ASSEMBLY, CYLINDER	-	-	-	-	-	1	-	-
21	J-2485	RING, CYLINDER RETAINING	1	1	1	1	1	1	1	1
22	G-1151-110716	SCREW, 5/8-18 X 1-3/4" SOCKET HD CAP	4	4	4	4	4	4	4	4

### Cylinder Assemblies Parts List

When ordering replacement parts/kits, please specify model, serial number and color of your unit.

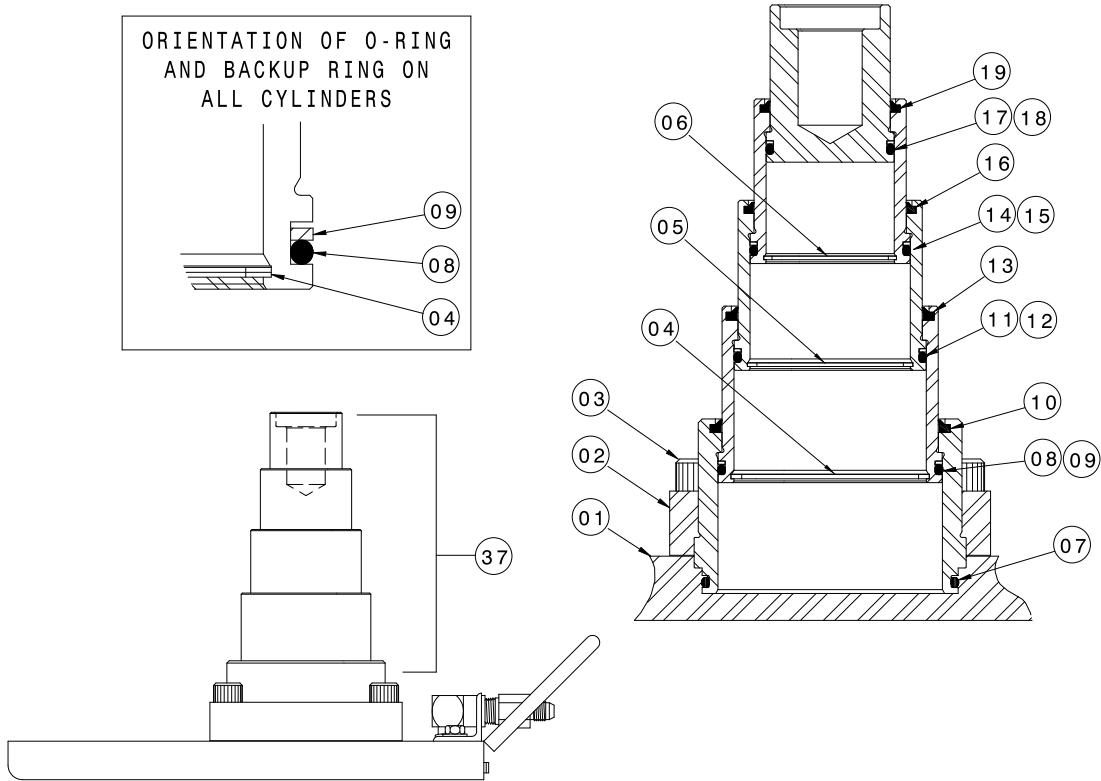

Item	Part Number	Description	Qty
	<b>K-2779</b>	<b>Kit, Cylinder Seal Replacement; consists of:</b>	
4	G-1398-300	First Cylinder Internal Ring	1
5	G-1398-250	Second Cylinder Internal Ring	1
6	G-1398-200	Third Cylinder Internal Ring	1
7	HC-2008-240	Main Cylinder O-ring	1
8	HC-2000-236	First Cylinder O-ring	1
9	HC-2023-236	First Cylinder Backup Ring	1
10	HC-1697-32	Main Cylinder Wiper	1
11	HC-2000-232	Second Cylinder O-ring	1
12	HC-2023-232	Second Cylinder Backup Ring	1
13	HC-1697-28	First Cylinder Wiper	1
14	HC-2000-228	Third Cylinder O-ring	1
15	HC-2023-228	Third Cylinder Backup Ring	1
16	HC-1697-24	Second Cylinder Wiper	1
17	HC-2000-224	Fourth Cylinder O-ring	1
18	HC-2023-224	Fourth Cylinder Backup Ring	1
19	HC-1697-20	Third Cylinder Wiper	1

**Parts List – 02-7833C0110**

When ordering replacement parts/kits, please specify model, serial number and color of your unit.

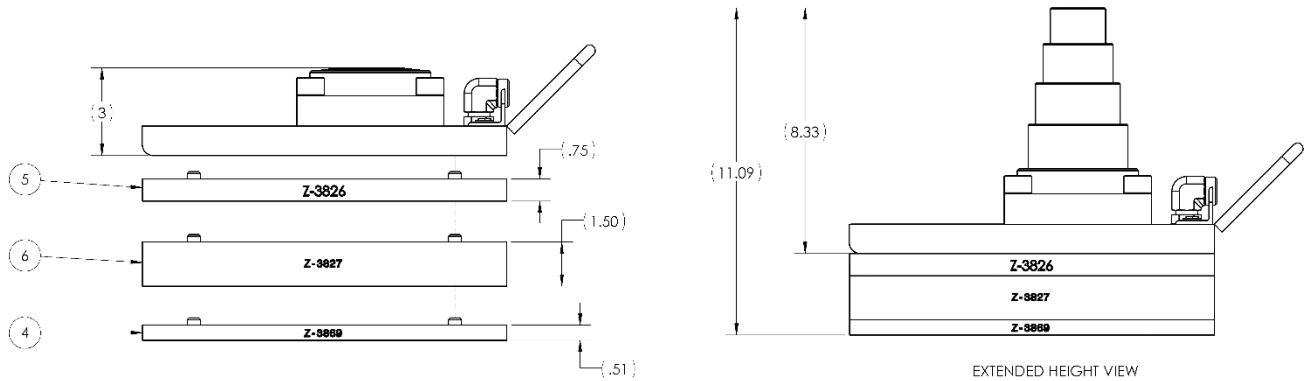
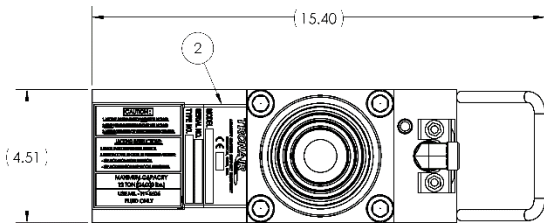
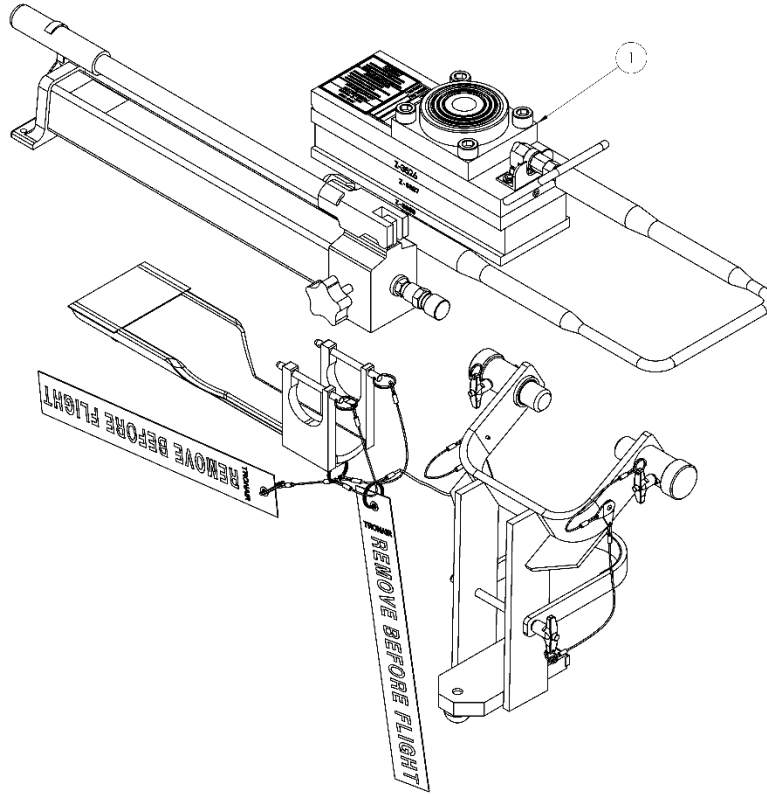

Item	Part Number	Description	Qty
1	Z-4936-Z7	ASSEMBLY, 12 TON AXLE JACK	1
2	V-2840	LABEL, JACK MODEL	1
4	Z-3869	ASSEMBLY, 1/2" BASE BLOCK	1
5	Z-3826	ASSEMBLY, 3/4" BASE BLOCK	1
6	Z-3827	ASSEMBLY, 1-1/2" BASE BLOCK	1

## Parts List – 02-7846C0110

When ordering replacement parts/kits, please specify model, serial number and color of your unit.

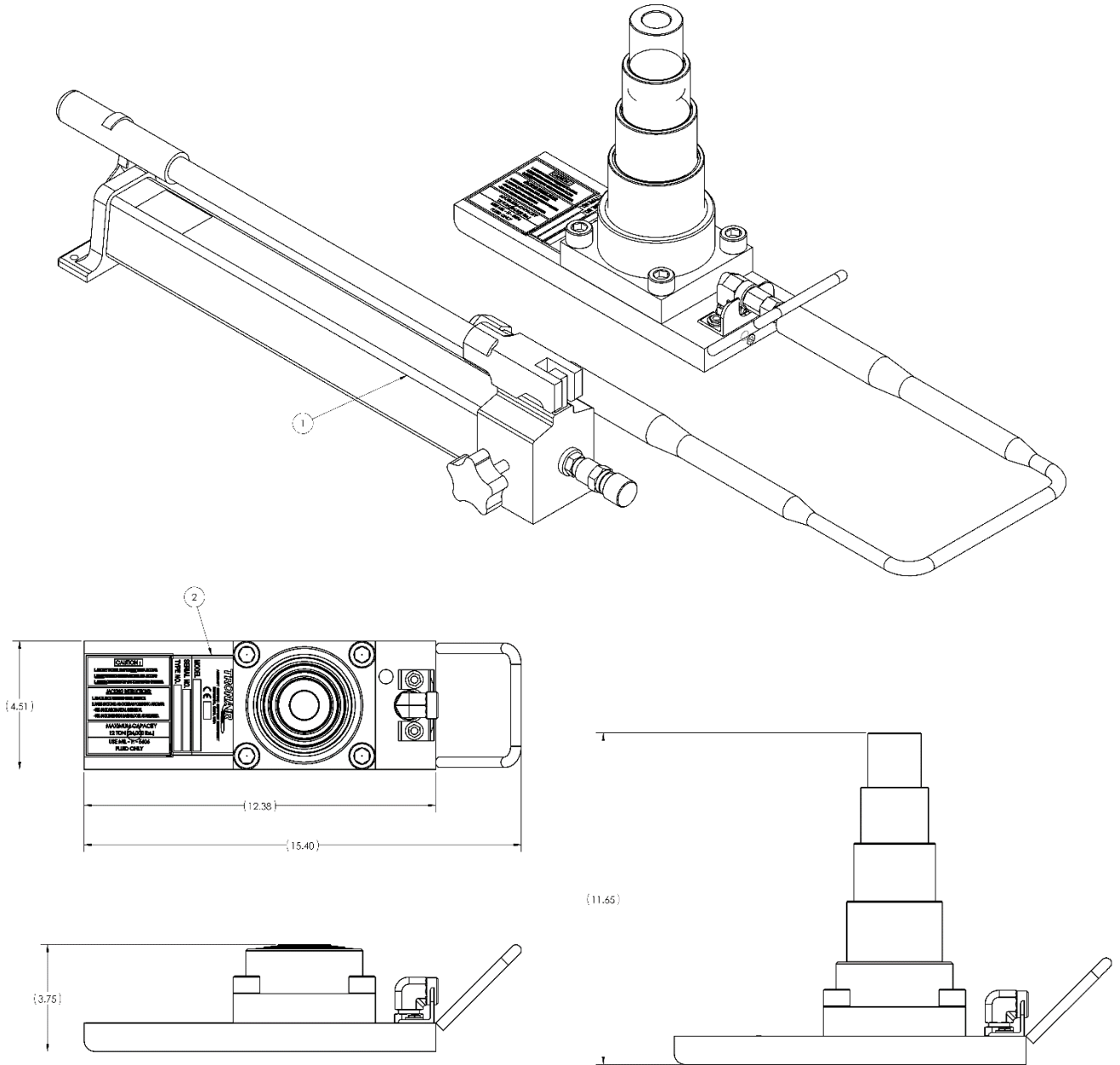

Item	Part Number	Description	Qty
1	Z-4936-Z7	ASSEMBLY, 12 TON AXLE JACK	1
2	V-2840	LABEL, JACK MODEL	1



## Parts List – 02-7852C0100

When ordering replacement parts/kits, please specify model, serial number and color of your unit.

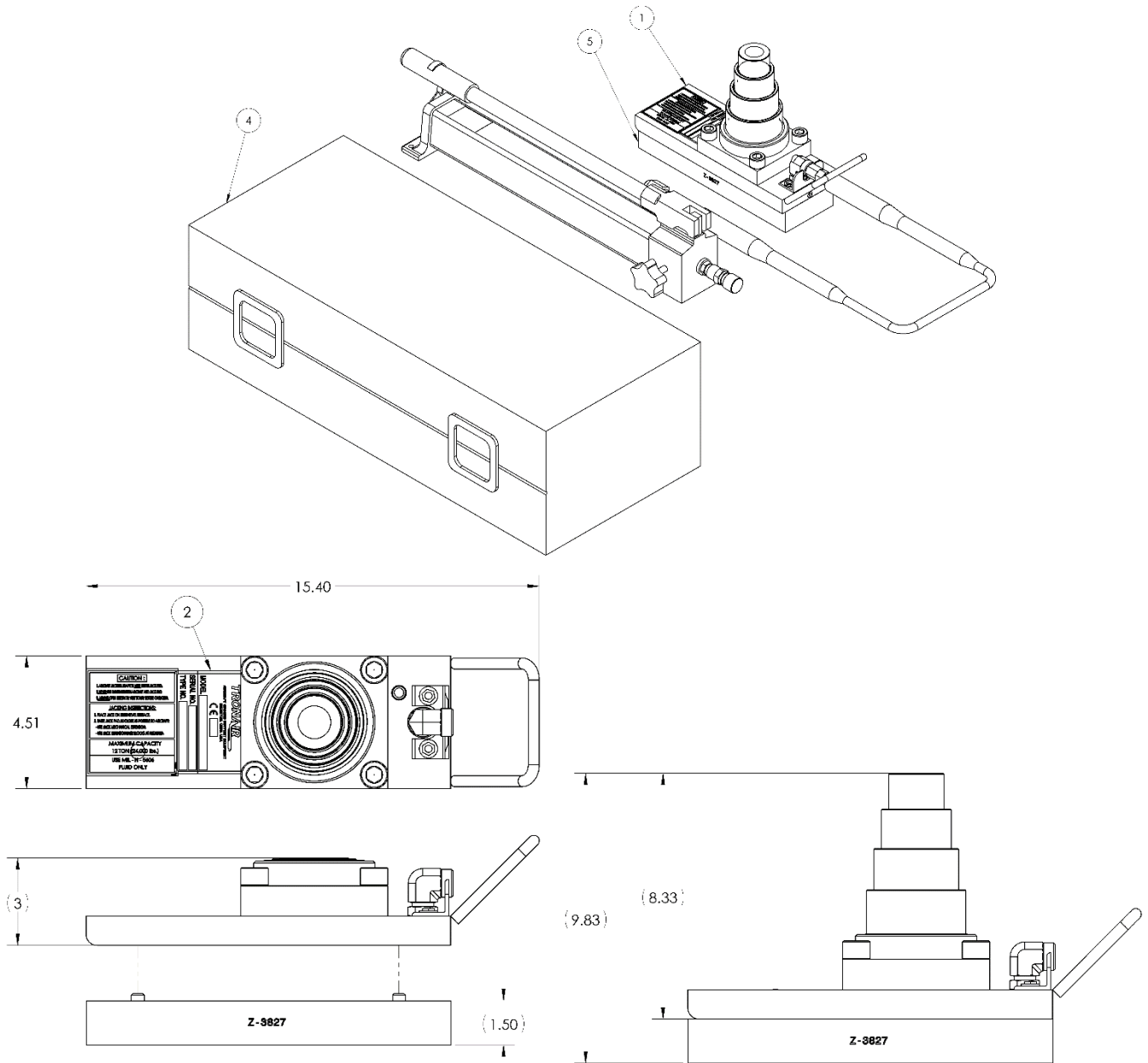

Item	Part Number	Description	Qty
1	Z-4936-Z2	ASSEMBLY, 12 TON AXLE JACK	1
2	V-2840	LABEL, JACK MODEL	1
4	H-4156	CASE, JACK TRANSPORT	1
5	Z-3827	ASSEMBLY, 1-1/2" BASE BLOCK	1

## Parts List – 02-7861C0100, 02-7861-9100

When ordering replacement parts/kits, please specify model, serial number and color of your unit.

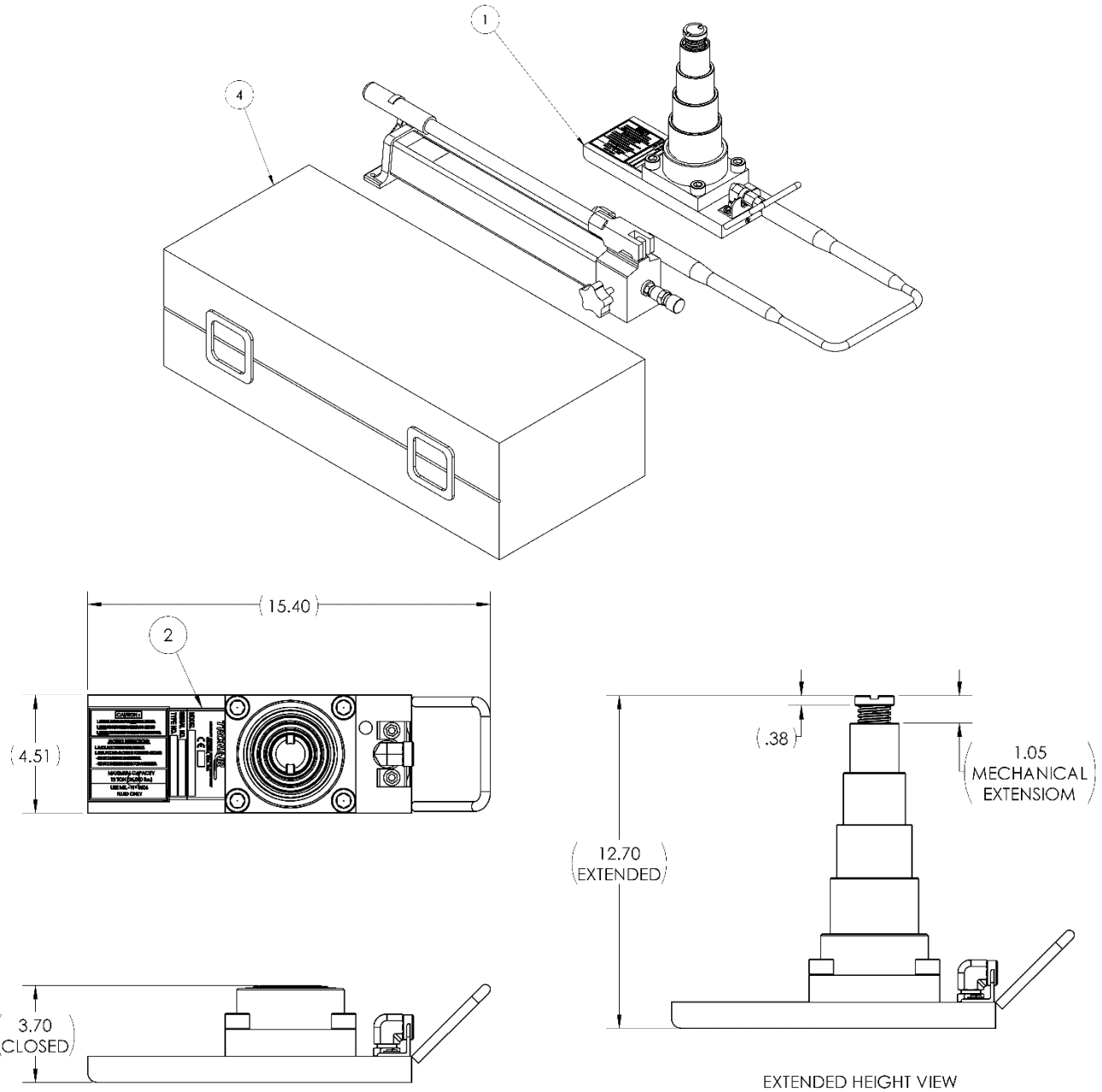

Item	Part Number	Description	Qty
1	Z-4936-Z3	ASSEMBLY, 12 TON AXLE JACK	1
2	V-2840	LABEL, JACK MODEL	1
4	H-4156	CASE, JACK TRANSPORT	1

NOTE: 02-7861-9100 is painted Yellow

## Parts List – 02-7863C0100

When ordering replacement parts/kits, please specify model, serial number and color of your unit.

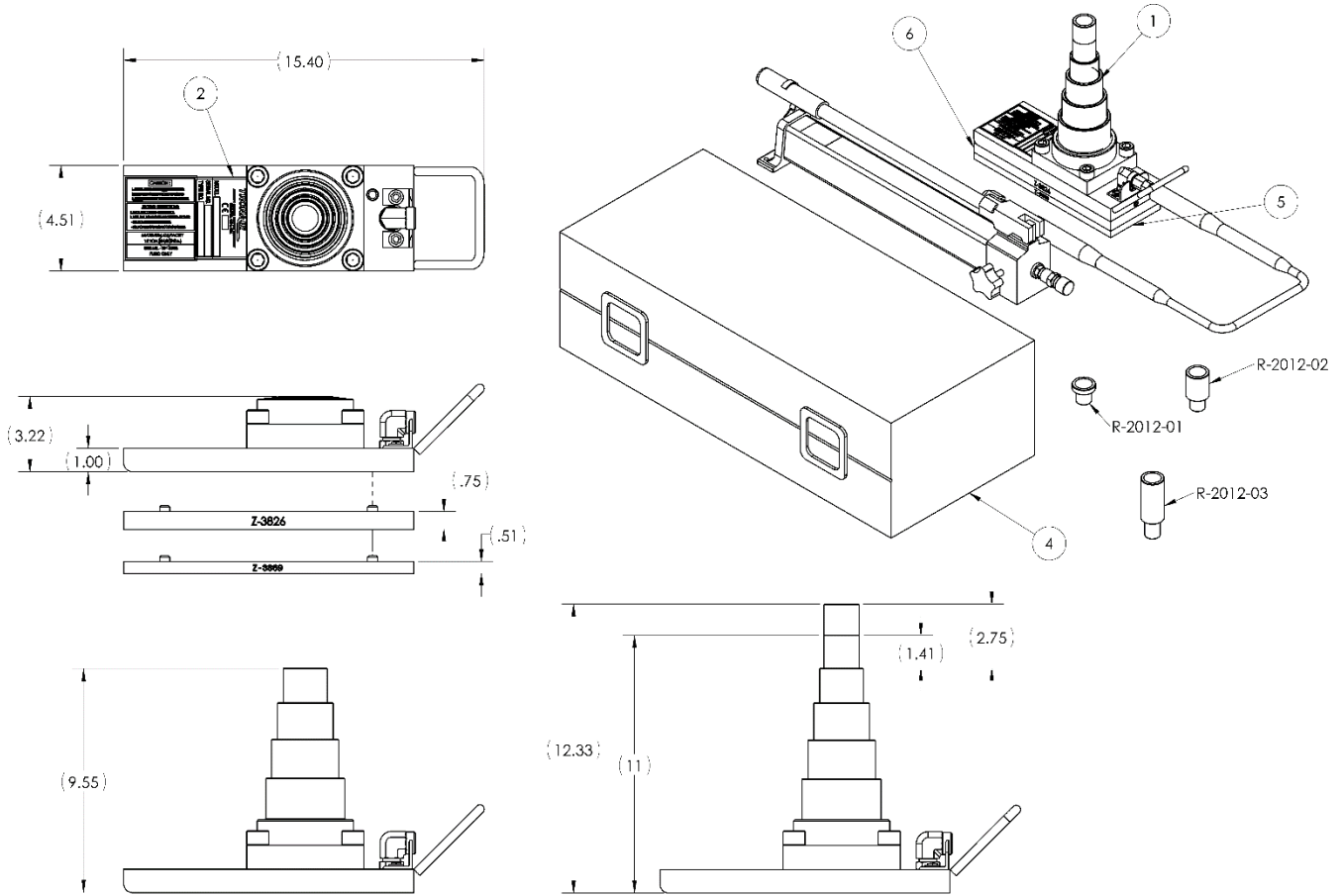

Item	Part Number	Description	Qty
1	Z-4936-Z1	ASSEMBLY, 12 TON AXLE JACK	1
2	V-2840	LABEL, JACK MODEL	1
4	H-4156	CASE, JACK TRANSPORT	1
5	Z-3869	ASSEMBLY, 1/2" BASE BLOCK	1
6	Z-3826	ASSEMBLY, 3/4" BASE BLOCK	1

## Parts List – 02-7902C0100

When ordering replacement parts/kits, please specify model, serial number and color of your unit.

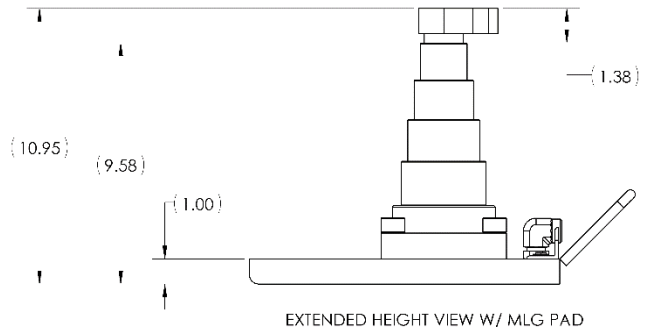
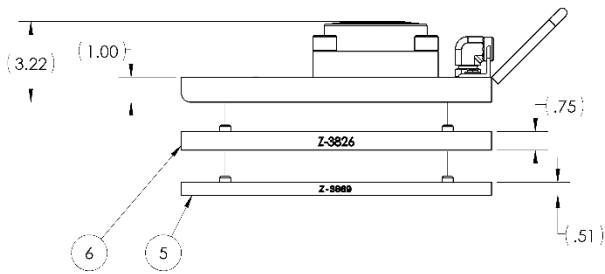
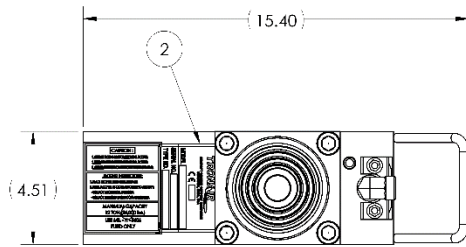
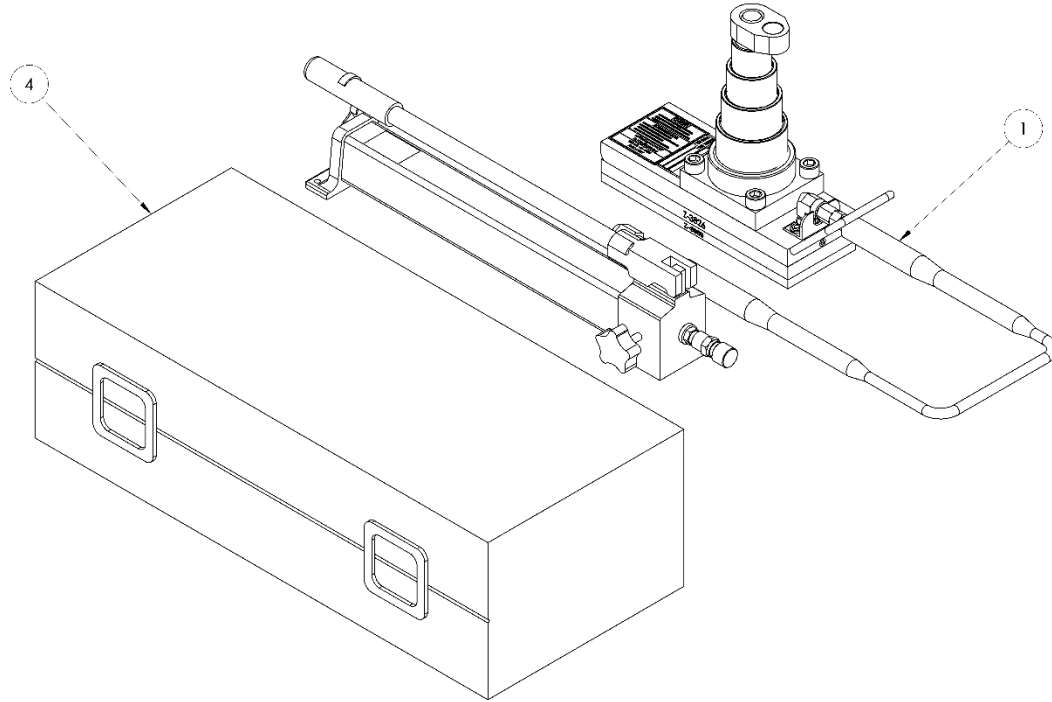

Item	Part Number	Description	Qty
1	Z-4936-Z8	ASSEMBLY, 12 TON AXLE JACK	1
2	V-2840	LABEL, JACK MODEL	1
4	H-4156	CASE, JACK TRANSPORT	1
5	Z-3869	ASSEMBLY, 1/2" BASE BLOCK	1
6	Z-3826	ASSEMBLY, 3/4" BASE BLOCK	1

## Parts List – 02-7918C0100, 02-7918C9100

When ordering replacement parts/kits, please specify model, serial number and color of your unit.

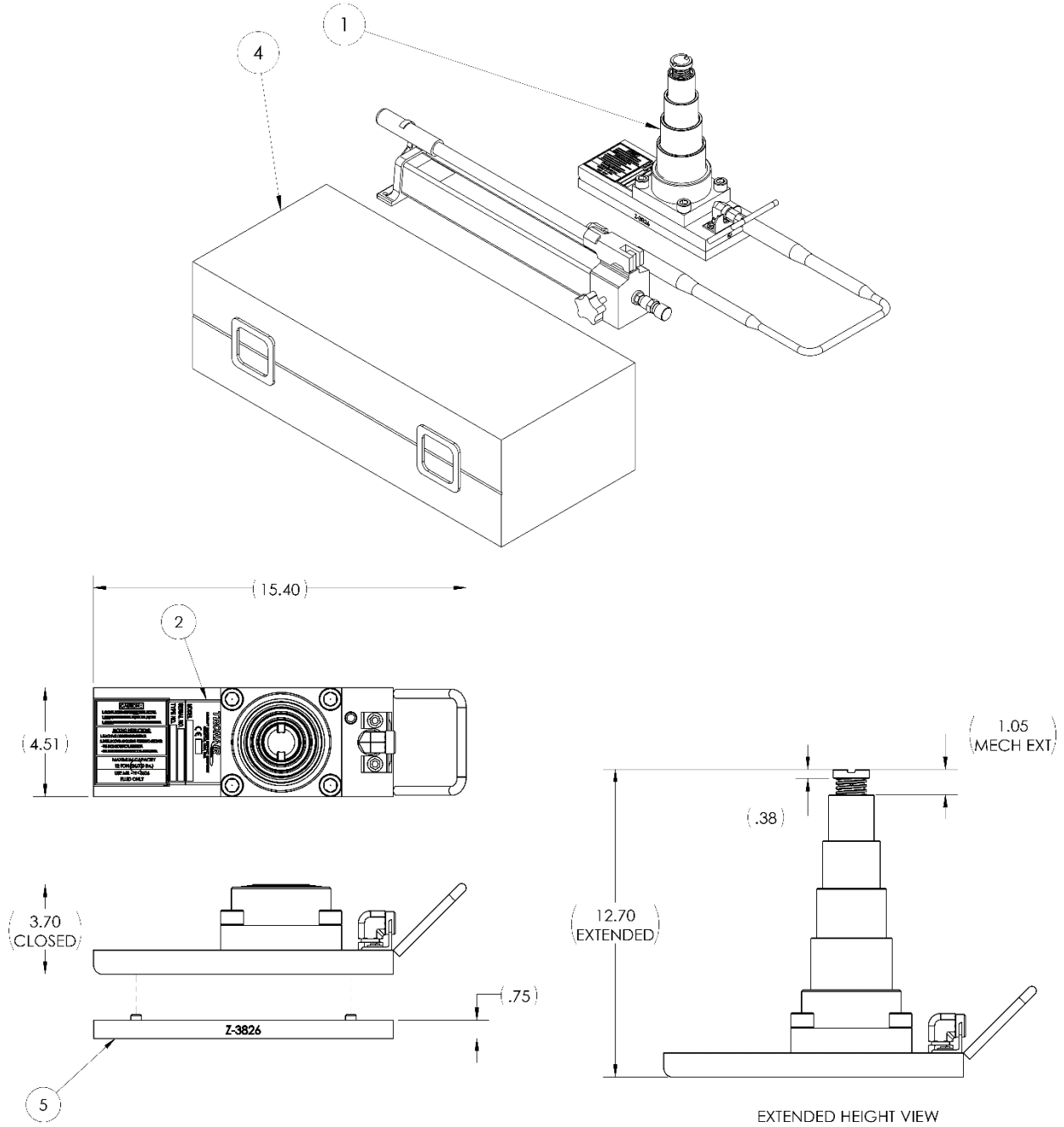

Item	Part Number	Description	Qty
1	Z-4936-Z3	ASSEMBLY, 12 TON AXLE JACK	1
2	V-2840	LABEL, JACK MODEL	1
4	H-4156	CASE, JACK TRANSPORT	1
5	Z-3826	ASSEMBLY, 3/4" BASE BLOCK	1

NOTE: 02-7918C9100 is painted Yellow



**APPENDIX I**

**Safety Data Sheet  
MIL-PRF-5606 Hydraulic Fluid**



## SAFETY DATA SHEET

**SECTION 1 PRODUCT AND COMPANY IDENTIFICATION****PRODUCT**

**Product Name:** MOBIL AERO HFA  
**Product Description:** Base Oil and Additives  
**Product Code:** 201550401020, 490110-00, 970584  
**Intended Use:** Aviation hydraulic oil

**COMPANY IDENTIFICATION**

**Supplier:** EXXON MOBIL CORPORATION  
22777 Springwoods Village Parkway  
Spring, TX. 77253 USA

**24 Hour Health Emergency** 609-737-4411  
**Transportation Emergency Phone** 800-424-9300 or 703-527-3887 CHEMTREC  
**Product Technical Information** 800-662-4525  
**MSDS Internet Address** <http://www.exxon.com>, <http://www.mobil.com>

**SECTION 2 HAZARDS IDENTIFICATION**

This material is hazardous according to regulatory guidelines (see (M)SDS Section 15).

**CLASSIFICATION:**

Flammable liquid: Category 4.  
Aspiration toxicant: Category 1.

**LABEL:**

Pictogram:



**Signal Word:** Danger

**Hazard Statements:**

H227: Combustible liquid. H304: May be fatal if swallowed and enters airways.

**Precautionary Statements:**

P210: Keep away from flames and hot surfaces. -- No smoking. P273: Avoid release to the environment. P280: Wear protective gloves and eye / face protection. P301 + P310: IF SWALLOWED: Immediately call a POISON CENTER or doctor/physician. P331: Do NOT induce vomiting. P370 + P378: In case of fire: Use water fog, foam, dry chemical or carbon dioxide (CO2) to extinguish. P403 + P235: Store in a well-ventilated place. Keep cool. P405: Store locked up. P501: Dispose of contents and container in accordance with local regulations.



Product Name: MOBIL AERO HFA  
 Revision Date: 01 Oct 2015  
 Page 2 of 12

**Other hazard information:**

**HAZARD NOT OTHERWISE CLASSIFIED (HNOC):** None as defined under 29 CFR 1910.1200.

**PHYSICAL / CHEMICAL HAZARDS**

Material can accumulate static charges which may cause an ignition. Material can release vapors that readily form flammable mixtures. Vapor accumulation could flash and/or explode if ignited. Combustible.

**HEALTH HAZARDS**

High-pressure injection under skin may cause serious damage. Excessive exposure may result in eye, skin, or respiratory irritation.

**ENVIRONMENTAL HAZARDS**

No significant hazards.

**NFPA Hazard ID:** Health: 1 Flammability: 2 Reactivity: 0  
**HMIS Hazard ID:** Health: 1\* Flammability: 2 Reactivity: 0

**NOTE:** This material should not be used for any other purpose than the intended use in Section 1 without expert advice. Health studies have shown that chemical exposure may cause potential human health risks which may vary from person to person.

**SECTION 3 COMPOSITION / INFORMATION ON INGREDIENTS**

This material is defined as a mixture.

**Hazardous Substance(s) or Complex Substance(s) required for disclosure**

Name	CAS#	Concentration*	GHS Hazard Codes
2,6-DI-TERT-BUTYL-P-CRESOL	128-37-0	0.1 - < 1%	H400(M factor 1), H410(M factor 1)
DISTILLATES (PETROLEUM), HYDROTREATED LIGHT	64742-47-8	5 - < 10%	H304
HYDROTREATED LIGHT NAPHTHENIC DISTILLATE (PETROLEUM)	64742-53-6	50 - < 70%	H227, H304
HYDROTREATED MIDDLE DISTILLATE (PETROLEUM)	64742-46-7	20 - < 30%	H304
TRIPHENYL PHOSPHATE	115-86-6	0.1 - < 0.25%	H400(M factor 1), H410(M factor 1)

\* All concentrations are percent by weight unless material is a gas. Gas concentrations are in percent by volume.

As per paragraph (i) of 29 CFR 1910.1200, formulation is considered a trade secret and specific chemical identity and exact percentage (concentration) of composition may have been withheld. Specific chemical identity and exact percentage composition will be provided to health professionals, employees, or designated representatives in accordance with applicable provisions of paragraph (i).

**SECTION 4 FIRST AID MEASURES**

**INHALATION**

Product Name: MOBIL AERO HFA

Revision Date: 01 Oct 2015

Page 3 of 12

Remove from further exposure. For those providing assistance, avoid exposure to yourself or others. Use adequate respiratory protection. If respiratory irritation, dizziness, nausea, or unconsciousness occurs, seek immediate medical assistance. If breathing has stopped, assist ventilation with a mechanical device or use mouth-to-mouth resuscitation.

#### SKIN CONTACT

Wash contact areas with soap and water. Remove contaminated clothing. Launder contaminated clothing before reuse. If product is injected into or under the skin, or into any part of the body, regardless of the appearance of the wound or its size, the individual should be evaluated immediately by a physician as a surgical emergency. Even though initial symptoms from high pressure injection may be minimal or absent, early surgical treatment within the first few hours may significantly reduce the ultimate extent of injury.

#### EYE CONTACT

Flush thoroughly with water. If irritation occurs, get medical assistance.

#### INGESTION

Seek immediate medical attention. Do not induce vomiting.

#### NOTE TO PHYSICIAN

If ingested, material may be aspirated into the lungs and cause chemical pneumonitis. Treat appropriately.

### SECTION 5 FIRE FIGHTING MEASURES

#### EXTINGUISHING MEDIA

**Appropriate Extinguishing Media:** Use water fog, foam, dry chemical or carbon dioxide (CO<sub>2</sub>) to extinguish flames.

**Inappropriate Extinguishing Media:** Straight Streams of Water

#### FIRE FIGHTING

**Fire Fighting Instructions:** Evacuate area. Prevent runoff from fire control or dilution from entering streams, sewers, or drinking water supply. Firefighters should use standard protective equipment and in enclosed spaces, self-contained breathing apparatus (SCBA). Use water spray to cool fire exposed surfaces and to protect personnel.

**Unusual Fire Hazards:** Combustible. Pressurized mists may form a flammable mixture.

**Hazardous Combustion Products:** Aldehydes, Incomplete combustion products, Oxides of carbon, Phosphorus oxides, Smoke, Fume, Sulfur oxides

#### FLAMMABILITY PROPERTIES

**Flash Point [Method]:** >82°C (180°F) [ASTM D-93]

**Flammable Limits (Approximate volume % in air):** LEL: 0.7 UEL: 7.0 [Estimated]

**Autoignition Temperature:** >225°C (437°F)

### SECTION 6 ACCIDENTAL RELEASE MEASURES

#### NOTIFICATION PROCEDURES

In the event of a spill or accidental release, notify relevant authorities in accordance with all applicable

Product Name: MOBIL AERO HFA

Revision Date: 01 Oct 2015

Page 4 of 12

regulations. US regulations require reporting releases of this material to the environment which exceed the applicable reportable quantity or oil spills which could reach any waterway including intermittent dry creeks. The National Response Center can be reached at (800)424-8802.

## PROTECTIVE MEASURES

Avoid contact with spilled material. Warn or evacuate occupants in surrounding and downwind areas if required due to toxicity or flammability of the material. See Section 5 for fire fighting information. See the Hazard Identification Section for Significant Hazards. See Section 4 for First Aid Advice. See Section 8 for advice on the minimum requirements for personal protective equipment. Additional protective measures may be necessary, depending on the specific circumstances and/or the expert judgment of the emergency responders.

For emergency responders: Respiratory protection: respiratory protection will be necessary only in special cases, e.g., formation of mists. Half-face or full-face respirator with filter(s) for dust/organic vapor or Self Contained Breathing Apparatus (SCBA) can be used depending on the size of spill and potential level of exposure. If the exposure cannot be completely characterized or an oxygen deficient atmosphere is possible or anticipated, SCBA is recommended. Work gloves that are resistant to hydrocarbons are recommended. Gloves made of polyvinyl acetate (PVA) are not water-resistant and are not suitable for emergency use. Chemical goggles are recommended if splashes or contact with eyes is possible. Small spills: normal antistatic work clothes are usually adequate. Large spills: full body suit of chemical resistant, antistatic material is recommended.

## SPILL MANAGEMENT

**Land Spill:** Eliminate all ignition sources (no smoking, flares, sparks or flames in immediate area). Stop leak if you can do it without risk. All equipment used when handling the product must be grounded. Do not touch or walk through spilled material. Prevent entry into waterways, sewer, basements or confined areas. A vapor suppressing foam may be used to reduce vapors. Use clean non-sparking tools to collect absorbed material. Absorb or cover with dry earth, sand or other non-combustible material and transfer to containers. Large Spills: Water spray may reduce vapor; but may not prevent ignition in closed spaces. Recover by pumping or with suitable absorbent.

**Water Spill:** Stop leak if you can do it without risk. Confine the spill immediately with booms. Warn other shipping. Remove from the surface by skimming or with suitable absorbents. Seek the advice of a specialist before using dispersants.

Water spill and land spill recommendations are based on the most likely spill scenario for this material; however, geographic conditions, wind, temperature, (and in the case of a water spill) wave and current direction and speed may greatly influence the appropriate action to be taken. For this reason, local experts should be consulted. Note: Local regulations may prescribe or limit action to be taken.

## ENVIRONMENTAL PRECAUTIONS

Large Spills: Dike far ahead of liquid spill for later recovery and disposal. Prevent entry into waterways, sewers, basements or confined areas.

## SECTION 7 HANDLING AND STORAGE

### HANDLING

Avoid contact with skin. Avoid prolonged breathing of mists and heated vapor. Prevent small spills and leakage to avoid slip hazard. Material can accumulate static charges which may cause an electrical spark (ignition source). When the material is handled in bulk, an electrical spark could ignite any flammable vapors from liquids or residues that may be present (e.g., during switch-loading operations). Use proper bonding and/or ground procedures. However, bonding and grounds may not eliminate the hazard from static

Product Name: MOBIL AERO HFA

Revision Date: 01 Oct 2015

Page 5 of 12

accumulation. Consult local applicable standards for guidance. Additional references include American Petroleum Institute 2003 (Protection Against Ignitions Arising out of Static, Lightning and Stray Currents) or National Fire Protection Agency 77 (Recommended Practice on Static Electricity) or CENELEC CLC/TR 50404 (Electrostatics - Code of practice for the avoidance of hazards due to static electricity).

**Static Accumulator:** This material is a static accumulator.

## STORAGE

The container choice, for example storage vessel, may effect static accumulation and dissipation. Keep container closed. Handle containers with care. Open slowly in order to control possible pressure release. Store in a cool, well-ventilated area. Storage containers should be grounded and bonded. Fixed storage containers, transfer containers and associated equipment should be grounded and bonded to prevent accumulation of static charge.

## SECTION 8 EXPOSURE CONTROLS / PERSONAL PROTECTION

### EXPOSURE LIMIT VALUES

**Exposure limits/standards (Note: Exposure limits are not additive)**

Substance Name	Form	Limit / Standard		NOTE	Source
2,6-DI-TERT-BUTYL-P-CRESOL	Inhalable fraction and vapor	TWA	2 mg/m <sup>3</sup>	N/A	ACGIH
DISTILLATES (PETROLEUM), HYDROTREATED LIGHT [total hydrocarbon vapor]	Non-Aerosol	TWA	200 mg/m <sup>3</sup>	Skin	ACGIH
HYDROTREATED LIGHT NAPHTHENIC DISTILLATE (PETROLEUM)	Mist.	TWA	5 mg/m <sup>3</sup>	N/A	OSHA Z1
HYDROTREATED LIGHT NAPHTHENIC DISTILLATE (PETROLEUM)	Inhalable fraction.	TWA	5 mg/m <sup>3</sup>	N/A	ACGIH
HYDROTREATED LIGHT NAPHTHENIC DISTILLATE (PETROLEUM)	Mist.	TWA	5 mg/m <sup>3</sup>	N/A	ACGIH
HYDROTREATED MIDDLE DISTILLATE (PETROLEUM)	Mist.	TWA	5 mg/m <sup>3</sup>	N/A	OSHA Z1
HYDROTREATED MIDDLE DISTILLATE (PETROLEUM)	Inhalable fraction.	TWA	5 mg/m <sup>3</sup>	N/A	ACGIH
TRIPHENYL PHOSPHATE		TWA	3 mg/m <sup>3</sup>	N/A	OSHA Z1
TRIPHENYL PHOSPHATE		TWA	3 mg/m <sup>3</sup>	N/A	ACGIH

**Exposure limits/standards for materials that can be formed when handling this product:** When mists/aerosols can occur the following are recommended: 5 mg/m<sup>3</sup> - ACGIH TLV (inhalable fraction), 5 mg/m<sup>3</sup> - OSHA PEL.

NOTE: Limits/standards shown for guidance only. Follow applicable regulations.

No biological limits allocated.

### ENGINEERING CONTROLS

The level of protection and types of controls necessary will vary depending upon potential exposure conditions.

---

Control measures to consider:  
Use explosion-proof ventilation equipment to stay below exposure limits.

## PERSONAL PROTECTION

Personal protective equipment selections vary based on potential exposure conditions such as applications, handling practices, concentration and ventilation. Information on the selection of protective equipment for use with this material, as provided below, is based upon intended, normal usage.

**Respiratory Protection:** If engineering controls do not maintain airborne contaminant concentrations at a level which is adequate to protect worker health, an approved respirator may be appropriate. Respirator selection, use, and maintenance must be in accordance with regulatory requirements, if applicable. Types of respirators to be considered for this material include:

No special requirements under ordinary conditions of use and with adequate ventilation.

For high airborne concentrations, use an approved supplied-air respirator, operated in positive pressure mode. Supplied air respirators with an escape bottle may be appropriate when oxygen levels are inadequate, gas/vapor warning properties are poor, or if air purifying filter capacity/rating may be exceeded.

**Hand Protection:** Any specific glove information provided is based on published literature and glove manufacturer data. Glove suitability and breakthrough time will differ depending on the specific use conditions. Contact the glove manufacturer for specific advice on glove selection and breakthrough times for your use conditions. Inspect and replace worn or damaged gloves. The types of gloves to be considered for this material include:

If prolonged or repeated contact is likely, chemical resistant gloves are recommended. If contact with forearms is likely, wear gauntlet style gloves.

**Eye Protection:** If contact is likely, safety glasses with side shields are recommended.

**Skin and Body Protection:** Any specific clothing information provided is based on published literature or manufacturer data. The types of clothing to be considered for this material include:

If prolonged or repeated contact is likely, chemical, and oil resistant clothing is recommended.

**Specific Hygiene Measures:** Always observe good personal hygiene measures, such as washing after handling the material and before eating, drinking, and/or smoking. Routinely wash work clothing and protective equipment to remove contaminants. Discard contaminated clothing and footwear that cannot be cleaned. Practice good housekeeping.

## ENVIRONMENTAL CONTROLS

Comply with applicable environmental regulations limiting discharge to air, water and soil. Protect the environment by applying appropriate control measures to prevent or limit emissions.

## SECTION 9

## PHYSICAL AND CHEMICAL PROPERTIES

**Note:** Physical and chemical properties are provided for safety, health and environmental considerations only and may not fully represent product specifications. Contact the Supplier for additional information.

## GENERAL INFORMATION

**Physical State:** Liquid  
**Color:** Red

Product Name: MOBIL AERO HFA  
 Revision Date: 01 Oct 2015  
 Page 7 of 12

**Odor:** Characteristic  
**Odor Threshold:** N/D

## IMPORTANT HEALTH, SAFETY, AND ENVIRONMENTAL INFORMATION

**Relative Density (at 15 °C):** 0.88  
**Flammability (Solid, Gas):** N/A  
**Flash Point [Method]:** >82°C (180°F) [ASTM D-93]  
**Flammable Limits (Approximate volume % in air):** LEL: 0.7 UEL: 7.0 [Estimated]  
**Autoignition Temperature:** >225°C (437°F)  
**Boiling Point / Range:** N/D  
**Decomposition Temperature:** N/D  
**Vapor Density (Air = 1):** N/D  
**Vapor Pressure:** [N/D at 20 °C]  
**Evaporation Rate (n-butyl acetate = 1):** N/D  
**pH:** N/A  
**Log Pow (n-Octanol/Water Partition Coefficient):** N/D  
**Solubility in Water:** Negligible  
**Viscosity:** 13.8 cSt (13.8 mm<sup>2</sup>/sec) at 40 °C | 5.1 cSt (5.1 mm<sup>2</sup>/sec) at 100°C [ASTM D 445]  
**Oxidizing Properties:** See Hazards Identification Section.

## OTHER INFORMATION

**Freezing Point:** N/D  
**Melting Point:** N/A  
**Pour Point:** -60°C (-76°F) [ASTM D97]  
**DMSO Extract (mineral oil only), IP-346:** < 3 %wt

## SECTION 10 STABILITY AND REACTIVITY

**REACTIVITY:** See sub-sections below.

**STABILITY:** Material is stable under normal conditions.

**CONDITIONS TO AVOID:** Open flames and high energy ignition sources.

**MATERIALS TO AVOID:** Strong oxidizers

**HAZARDOUS DECOMPOSITION PRODUCTS:** Material does not decompose at ambient temperatures.

**POSSIBILITY OF HAZARDOUS REACTIONS:** Hazardous polymerization will not occur.

## SECTION 11 TOXICOLOGICAL INFORMATION

### INFORMATION ON TOXICOLOGICAL EFFECTS

Hazard Class	Conclusion / Remarks
<b>Inhalation</b>	
Acute Toxicity: No end point data for material.	Minimally Toxic. Based on assessment of the components.
Irritation: No end point data for material.	Elevated temperatures or mechanical action may form vapors, mist, or fumes which may be irritating to the eyes, nose, throat, or lungs.

Product Name: MOBIL AERO HFA

Revision Date: 01 Oct 2015

Page 8 of 12

<b>Ingestion</b>	
Acute Toxicity: No end point data for material.	Minimally Toxic. Based on assessment of the components.
<b>Skin</b>	
Acute Toxicity: No end point data for material.	Minimally Toxic. Based on assessment of the components.
Skin Corrosion/Irritation: No end point data for material.	May dry the skin leading to discomfort and dermatitis. Based on assessment of the components.
<b>Eye</b>	
Serious Eye Damage/Irritation: No end point data for material.	May cause mild, short-lasting discomfort to eyes. Based on assessment of the components.
<b>Sensitization</b>	
Respiratory Sensitization: No end point data for material.	Not expected to be a respiratory sensitizer.
Skin Sensitization: No end point data for material.	Not expected to be a skin sensitizer. Based on assessment of the components.
<b>Aspiration:</b> Data available.	May be fatal if swallowed and enters airways. Based on physico-chemical properties of the material.
<b>Germ Cell Mutagenicity:</b> No end point data for material.	Not expected to be a germ cell mutagen. Based on assessment of the components.
<b>Carcinogenicity:</b> No end point data for material.	Not expected to cause cancer. Based on assessment of the components.
<b>Reproductive Toxicity:</b> No end point data for material.	Not expected to be a reproductive toxicant. Based on assessment of the components.
<b>Lactation:</b> No end point data for material.	Not expected to cause harm to breast-fed children.
<b>Specific Target Organ Toxicity (STOT)</b>	
Single Exposure: No end point data for material.	Not expected to cause organ damage from a single exposure.
Repeated Exposure: No end point data for material.	Not expected to cause organ damage from prolonged or repeated exposure. Based on assessment of the components.

#### TOXICITY FOR SUBSTANCES

NAME	ACUTE TOXICITY
2,6-DI-TERT-BUTYL-P-CRESOL	Oral Lethality: LD50 0.89 g/kg (Rat)

#### OTHER INFORMATION

##### For the product itself:

Repeated and/or prolonged exposure may cause irritation to the skin, eyes, or respiratory tract. Small amounts of liquid aspirated into the lungs during ingestion or from vomiting may cause chemical pneumonitis or pulmonary edema.

##### Contains:

Base oil severely refined: Not carcinogenic in animal studies. Representative material passes IP-346, Modified Ames test, and/or other screening tests. Dermal and inhalation studies showed minimal effects; lung non-specific infiltration of immune cells, oil deposition and minimal granuloma formation. Not sensitizing in test animals.

The following ingredients are cited on the lists below: None.

--REGULATORY LISTS SEARCHED--

Product Name: MOBIL AERO HFA  
Revision Date: 01 Oct 2015  
Page 9 of 12

1 = NTP CARC  
2 = NTP SUS

3 = IARC 1  
4 = IARC 2A

5 = IARC 2B  
6 = OSHA CARC

## SECTION 12 ECOLOGICAL INFORMATION

The information given is based on data available for the material, the components of the material, and similar materials.

### ECOTOXICITY

Material -- Not expected to be harmful to aquatic organisms.

### MOBILITY

More volatile component -- Highly volatile, will partition rapidly to air. Not expected to partition to sediment and wastewater solids.

Less volatile component -- Low solubility and floats and is expected to migrate from water to the land. Expected to partition to sediment and wastewater solids.

### PERSISTENCE AND DEGRADABILITY

#### Biodegradation:

Components -- Expected to be inherently biodegradable

### BIOACCUMULATION POTENTIAL

Majority of components -- Has the potential to bioaccumulate, however metabolism or physical properties may reduce the bioconcentration or limit bioavailability.

## SECTION 13 DISPOSAL CONSIDERATIONS

Disposal recommendations based on material as supplied. Disposal must be in accordance with current applicable laws and regulations, and material characteristics at time of disposal.

### DISPOSAL RECOMMENDATIONS

Product is suitable for burning in an enclosed controlled burner for fuel value or disposal by supervised incineration at very high temperatures to prevent formation of undesirable combustion products. Protect the environment. Dispose of used oil at designated sites. Minimize skin contact. Do not mix used oils with solvents, brake fluids or coolants.

### REGULATORY DISPOSAL INFORMATION

RCRA Information: The unused product, in our opinion, is not specifically listed by the EPA as a hazardous waste (40 CFR, Part 261D), nor is it formulated to contain materials which are listed as hazardous wastes. It does not exhibit the hazardous characteristics of ignitability, corrosivity or reactivity and is not formulated with contaminants as determined by the Toxicity Characteristic Leaching Procedure (TCLP). However, used product may be regulated.

**Empty Container Warning** Empty Container Warning (where applicable): Empty containers may contain residue and can be dangerous. Do not attempt to refill or clean containers without proper instructions. Empty drums should be



Product Name: MOBIL AERO HFA  
Revision Date: 01 Oct 2015  
Page 10 of 12

completely drained and safely stored until appropriately reconditioned or disposed. Empty containers should be taken for recycling, recovery, or disposal through suitably qualified or licensed contractor and in accordance with governmental regulations. DO NOT PRESSURISE, CUT, WELD, BRAZE, SOLDER, DRILL, GRIND, OR EXPOSE SUCH CONTAINERS TO HEAT, FLAME, SPARKS, STATIC ELECTRICITY, OR OTHER SOURCES OF IGNITION. THEY MAY EXPLODE AND CAUSE INJURY OR DEATH.

## SECTION 14 TRANSPORT INFORMATION

### LAND (DOT)

**Proper Shipping Name:** COMBUSTIBLE LIQUID, N.O.S. (Distillates (Petroleum), Hydrotreated Light)  
**Hazard Class & Division:** COMBUSTIBLE LIQUID  
**ID Number:** NA1993  
**Packing Group:** III  
**ERG Number:** 128  
**Label(s):** NONE  
**Transport Document Name:** NA1993, COMBUSTIBLE LIQUID, N.O.S. (Distillates (Petroleum), Hydrotreated Light), COMBUSTIBLE LIQUID, PG III

Footnote: This material is not regulated under 49 CFR in a container of 119 gallon capacity or less when transported solely by land, as long as the material is not a hazardous waste, a marine pollutant, or specifically listed as a hazardous substance.

**LAND (TDG):** Not Regulated for Land Transport

**SEA (IMDG):** Not Regulated for Sea Transport according to IMDG-Code

**Marine Pollutant:** No

**AIR (IATA):** Not Regulated for Air Transport

## SECTION 15 REGULATORY INFORMATION

**OSHA HAZARD COMMUNICATION STANDARD:** This material is considered hazardous in accordance with OSHA HazCom 2012, 29 CFR 1910.1200.

**Listed or exempt from listing/notification on the following chemical inventories:** AICS, DSL, ENCS, IECSC, KECI, PICCS, TCSI, TSCA

**EPCRA SECTION 302:** This material contains no extremely hazardous substances.

**SARA (311/312) REPORTABLE HAZARD CATEGORIES:** Fire. Immediate Health. Delayed Health.

**SARA (313) TOXIC RELEASE INVENTORY:** This material contains no chemicals subject to the supplier notification requirements of the SARA 313 Toxic Release Program.

Product Name: MOBIL AERO HFA  
 Revision Date: 01 Oct 2015  
 Page 11 of 12

The following ingredients are cited on the lists below:

Chemical Name	CAS Number	List Citations
DISTILLATES (PETROLEUM), HYDROTREATED LIGHT	64742-47-8	1, 17, 18
HYDROTREATED LIGHT NAPHTHENIC DISTILLATE (PETROLEUM)	64742-53-6	1, 4, 13, 17, 18
HYDROTREATED MIDDLE DISTILLATE (PETROLEUM)	64742-46-7	1, 4, 17, 18

--REGULATORY LISTS SEARCHED--

1 = ACGIH ALL	6 = TSCA 5a2	11 = CA P65 REPRO	16 = MN RTK
2 = ACGIH A1	7 = TSCA 5e	12 = CA RTK	17 = NJ RTK
3 = ACGIH A2	8 = TSCA 6	13 = IL RTK	18 = PA RTK
4 = OSHA Z	9 = TSCA 12b	14 = LA RTK	19 = RI RTK
5 = TSCA 4	10 = CA P65 CARC	15 = MI 293	

Code key: CARC=Carcinogen; REPRO=Reproductive

<b>SECTION 16</b>	<b>OTHER INFORMATION</b>
-------------------	--------------------------

N/D = Not determined, N/A = Not applicable

**KEY TO THE H-CODES CONTAINED IN SECTION 3 OF THIS DOCUMENT (for information only):**

H227: Combustible liquid; Flammable Liquid, Cat 4  
 H304: May be fatal if swallowed and enters airways; Aspiration, Cat 1  
 H400: Very toxic to aquatic life; Acute Env Tox, Cat 1  
 H410: Very toxic to aquatic life with long lasting effects; Chronic Env Tox, Cat 1

**THIS SAFETY DATA SHEET CONTAINS THE FOLLOWING REVISIONS:**

Revision Changes:  
 Section 01: Company Mailing Address information was modified.  
 Section 05: Hazardous Combustion Products information was modified.  
 Section 15: List Citations Table information was modified.  
 Section 15: National Chemical Inventory Listing information was modified.  
 Section 14: Marine Pollutant information was modified.  
 Composition: Component Table information was modified.  
 Section 08: Exposure Limits Table information was modified.  
 Section 16: Revision Information - Implementation of GHS requirements phrase. information was deleted.

The information and recommendations contained herein are, to the best of ExxonMobil's knowledge and belief, accurate and reliable as of the date issued. You can contact ExxonMobil to insure that this document is the most current available from ExxonMobil. The information and recommendations are offered for the user's consideration and examination. It is the user's responsibility to satisfy itself that the product is suitable for the intended use. If buyer repackages this product, it is the user's responsibility to insure proper health, safety and other necessary information is included with and/or on the container. Appropriate warnings and safe-handling procedures should be provided to handlers and users. Alteration of this document is strictly prohibited. Except to the extent required by law,



Product Name: MOBIL AERO HFA

Revision Date: 01 Oct 2015

Page 12 of 12

---

re-publication or retransmission of this document, in whole or in part, is not permitted. The term, "ExxonMobil" is used for convenience, and may include any one or more of ExxonMobil Chemical Company, Exxon Mobil Corporation, or any affiliates in which they directly or indirectly hold any interest.

---

Internal Use Only

MHC: 2A, 0, 0, 0, 1, 1

PPEC: C

DGN: 2005454XUS (552975)

---

Copyright 2002 Exxon Mobil Corporation, All rights reserved



## **APPENDIX II**

### **Declaration of Conformity**





## DECLARATION of CONFORMITY

The design, development and manufacture is in accordance with European Community guidelines

Axle Jacks  
02-7833C0110  
02-7846C0110  
02-7852C0100  
02-7861C0100  
02-7863C0100  
02-7902C0100  
02-7918C0100  
02-7918C9100

Relevant provisions complied with by the machinery:  
2006/42/EC

Relevant standards complied with by the machinery:  
EN ISO 12100-1

Identification of person empowered to sign on behalf of the Manufacturer:

A handwritten signature in cursive script that reads "Patrick Finch". The signature is written in black ink and is positioned above a horizontal line.

Quality Assurance Representative





## **APPENDIX III**

### **Maintenance Schedule**





## Axle Jacks

Tronair recommends performing preventative maintenance on all jacks, which should include a 90-day routine inspection and a 12-month load test.

Model Number \_\_\_\_\_ Serial Number \_\_\_\_\_

Maintenance Performed By \_\_\_\_\_ Date \_\_\_\_\_

### 90-Day Maintenance:

- Check hydraulic system for leaks including the following:
  - Hand pump; cylinder, fittings and seals
  - Reservoir; welds and fittings
- Check jack structure for corrosion, bending, cracking and excessive wear including the following:
  - Base plate
  - Mechanical extension
  - Hydraulic cylinder assembly
  - Retaining ring (secures the cylinder to the base plate)
  - Jack pads, nose and main gear adapters
  - Spacer blocks
- Check fluid level with rams fully retracted. See manual for proper level height
- Extend rams and visually inspect for corrosion, foreign matter, excessive wear and leaks around ram seals. Remove any foreign matter
- Check paint condition, touch-up areas that are exposed
- Actuate the hand pump and raise the ram to full extension at least once.  
**Do not** pressurize hydraulic system once fully extended  
**Do not** allow jack to miss-stage when raising the rams to full extension
- Extend rams and visually inspect for corrosion, foreign matter, excessive wear and leaks around ram seals. Remove any foreign matter
- Open release valve and verify that rams fully retract

### Annual (12-Month) Maintenance:

- Check hydraulic fluid for contamination (dirt/water) drain and flush if required
- Perform 90-day maintenance checklist
- Capacity test (110% of jack's rated capacity)

**NOTE:** The jack may be returned to Tronair for load testing, or sent to a local hydraulic repair shop. Please contact Tronair to obtain a "Return Material Authorization Number" (RMA #) before sending any product to Tronair.

the Tronair group of companies:

[www.tronair.com](http://www.tronair.com) | [www.columbusjack.com](http://www.columbusjack.com) | [www.daeind.com](http://www.daeind.com) | [www.datcomedia.com](http://www.datcomedia.com) | [www.eagletugs.com](http://www.eagletugs.com) | [www.malabar.com](http://www.malabar.com)