

**Models: 02A7912C0100
02A7917C0100
15 Ton (13.4 Metric Ton)
Three Stage Jack**



12/2023 – Rev. 05

**For Spare Parts, Operations & Service Manuals or Service Needs
Scan the QR code or visit Tronair.com/aftermarket**



REVISION	DATE	TEXT AFFECTED
01	03/2011	Original Release
02	02/2012	Modified 3.0 Specifications, 5.1 Jack Instructions, 6.2 Servicing Jack
03	03/2013	Major Revision
04	06/2021	Major Revision
05	12/2023	Modified Parts List

TABLE OF CONTENTS

PAGE

1.0	PRODUCT INFORMATION	1
1.1	DESCRIPTION	1
1.2	MODEL & SERIAL NUMBER	1
1.3	MANUFACTURER	1
1.4	SPECIFICATIONS	1
2.0	SAFETY INFORMATION	1
2.1	WARNING AND DANGER SIGNS	1
2.2	COMPONENT SAFETY FEATURES	1
2.3	FUNCTIONAL SAFETY FEATURES:	1
2.4	FEATURES FOR OPERATOR SAFETY:	1
2.5	ENVIRONMENTAL SAFETY FEATURES:	1
2.6	NECESSARY PERSONAL PROTECTIVE EQUIPMENT	1
2.7	SAFETY GUIDELINES	2
2.8	CONDITIONS FOR SAFE USE	2
2.9	OPERATOR QUALIFICATIONS	2
2.10	ADDITIONAL SAFETY MEASURES	2
2.11	IN CASE OF HYDRAULIC LINE FAILURE	2
3.0	TRAINING	2
3.1	TRAINING REQUIREMENTS	2
3.2	TRAINING PROGRAM	2
3.3	OPERATOR TRAINING	2
4.0	ASSEMBLY	3
4.1	GENERAL INSTRUCTIONS	3
4.2	PRE-USE CHECKS	3
4.3	PERSONNEL REQUIREMENTS:	3
4.4	INSPECTION AND TEST PROCEDURES:	3
5.0	INSTALLATION	3
5.1	AIR SUPPLY REQUIREMENTS:	3
6.0	OPERATION	4
6.1	OPERATING PARAMETERS:	4
6.2	NUMERICAL VALUES	4
6.3	OPERATOR CONTROLS	4
6.4	OPERATING INSTRUCTIONS	5
6.4.1	Rules For Operating	5
6.4.2	Jack Instructions	5
7.0	PACKAGING AND STORAGE	6
7.1	PACKAGING REQUIREMENTS	6
7.2	HANDLING	6
7.3	STRAPPING	6
7.4	PACKAGING PROTECTION	6
7.5	LABELING OF PACKAGING	6
7.6	STORAGE COMPATIBILITY	6
7.7	STORAGE ENVIRONMENT	6
7.8	STORAGE SPACE AND HANDLING FACILITIES	6
8.0	TRANSPORTATION	6
9.0	TROUBLE SHOOTING	6
10.0	MAINTENANCE	7
10.1	GENERAL	7
10.2	MAINTENANCE SCHEDULE	7
10.2.1	Storage/Low Usage	7
10.3	SERVICING JACK	7
10.4	JACK FUNCTION LOAD TEST	7
10.5	PNEUMATIC PUMP	7
11.0	PROVISION OF SPARES	8
11.1	SOURCE OF SPARE PARTS	8
11.2	RECOMMENDED SPARE PARTS LISTS	8
12.0	IN SERVICE SUPPORT	8
13.0	GUARANTEES/LIMITATION OF LIABILITY	8
14.0	APPENDICES	8

This product can not be modified without the written approval of Tronair, Inc. Any modifications done without written approval voids all warranties and releases Tronair, Inc., its suppliers, distributors, employees, or financial institutions from any liability from consequences that may occur. Only Tronair OEM replacement parts shall be used.

1.0 PRODUCT INFORMATION

1.1 DESCRIPTION

The device is intended to lift an aircraft by its fuselage and/or main wing with other hydraulic jacks arranged by position and quantity to provide proper balance, and in conjunction with the correct jack pad, whose maximum load on any one jack does not exceed the rated capacity of the jack.

The jacks are not intended for metal forming, metal working, or any purpose other than that stated above.

1.2 MODEL & SERIAL NUMBER

Reference nameplate on unit

1.3 MANUFACTURER

TRONAIR, Inc.

1 Air Cargo Pkwy East
Swanton, Ohio 43558 USA

Telephone: (419) 866-6301 or 800-426-6301

Fax: (419) 867-0634

E-mail: sales@tronair.com

Website: www.tronair.com

1.4 SPECIFICATIONS

Rated Capacity	30,000 lbs (13,607 kg)
Minimum Closed Height	20 in (50.8 cm)
Mechanical Extension	4 in (10.2 cm)
Hydraulic Extension 1st Stage	11.16 in (28.3 cm)
Hydraulic Extension 2nd Stage	11.94 in (30.3 cm)
Hydraulic Extension 3rd Stage	12.59 in (31.9 cm)
Maximum Height Obtainable	59 in (149.9 cm)
Weight	390 lbs (177 kg)

2.0 SAFETY INFORMATION

2.1 WARNING AND DANGER SIGNS

See labels on unit.



WARNING!

The ram locknuts are user operated safety devices. Failure to utilize these locknuts may result in personal injury or death.

2.2 COMPONENT SAFETY FEATURES

- **Ram Locknut** prevents lowering of the ram. The Ram Locknut must be lowered as the aircraft is being lifted.
- **Locknut Retention Ring** prevents locknut from being unscrewed from the 2nd and 3rd stages.
- **Hold to Run Air Valve** requires the operator to hold the air valve lever to raise the ram using the air pump. Releasing the air valve lever stops upward movement of the ram.
- **CE Hand Pump With Check Valve** prevents unintentional descent of aircraft if relief valve fails.

2.3 FUNCTIONAL SAFETY FEATURES:

- **Pressure Relief Valve** prevents overload during raising operations.

2.4 FEATURES FOR OPERATOR SAFETY:

- Hold to Run Air Valve
- Air Shut Off Valve
- Cautions And Instruction Labels Located on Jack
- Ram Locknut
- Locknut Retaining Ring on 2nd and 3rd Stages

2.5 ENVIRONMENTAL SAFETY FEATURES:

Jack is non-polluting. See Appendix IV Safety Data Sheet for the recommended hydraulic fluid (MIL-PRF-5606).

2.6 NECESSARY PERSONAL PROTECTIVE EQUIPMENT



CAUTION!

Always wear safety glasses.

2.7 SAFETY GUIDELINES

**CAUTION!**

Do not place hands on top of jack near ram locknuts while lowering jack.

Pinch points exist between top of jack and threads on ram.

- Never put hands between the aircraft and the jack pad; as after aircraft has been lowered, struts may have hung up.
- Never align jack under aircraft by pounding on jack legs. Dented legs may lead to jack collapse.
- Always lower ram locking nut(s) after jack is under load. Be sure ram nut(s) is seated fully after jacking.
- Always raise and lower jacks simultaneously so that aircraft remains level.
- Always use a tail or nose stand, as applicable, for additional stability.

**WARNING!**

The ram locknuts are user operated safety devices.
Failure to utilize these locknuts may result in personal injury or death.

2.8 CONDITIONS FOR SAFE USE

- Use in a clean dry environment on a level surface.
- Operate between -20° C and 50°C/-4° F and 122° F.

2.9 OPERATOR QUALIFICATIONS

This jack is intended to be used by the skilled and trained aircraft technician. The operator must be familiar with the jacking procedures for the aircraft to be raised, and the operation of the jack.

Installation/Maintenance/Dismantling Qualifications: This jack is to be installed, maintained, and dismantled by qualified technicians familiar with hydraulic systems.

2.10 ADDITIONAL SAFETY MEASURES

This jack must be used in accordance with this technical manual, and in accordance with the aircraft manufacturer's jacking procedures.

2.11 IN CASE OF HYDRAULIC LINE FAILURE

Ram Locknut prevents unintentional decent in case of hydraulic failure. It is important to keep Ram Locknut within 1 inch of bottom of ram when lowering or raising aircraft.

3.0 TRAINING

3.1 TRAINING REQUIREMENTS

The employer of the operator is responsible for providing a training program sufficient for the safe operation of the unit.

3.2 TRAINING PROGRAM

The employer provided operator training program should cover safety procedures concerning use of the unit in and around the intended aircraft at the intended aircraft servicing location.

3.3 OPERATOR TRAINING

The operator training should provide the required training for safe operation of the unit.

NOTE: Maintenance and Trouble Shooting are to be performed by a skilled and trained technician.

4.0 ASSEMBLY

This product is shipped completely assembled and tested and requires no further assembly before operation. The following sections apply when servicing the unit.

4.1 GENERAL INSTRUCTIONS

- This product should be assembled and/or repaired using good workmanship practices and proper tools. Bolts and elastic stopnuts should be tightened to a torque not to exceed industry standards for Grade '5' bolts.
- All replacement parts must be the same as or better than the original parts supplied.
- Dispose of waste per federal and local laws and regulations.
- No modifications are allowed that will adversely affect the jack's safety performance.
- The pressure relief valve is not serviceable. It must be replaced as a unit.

4.2 PRE-USE CHECKS

1. Refer to the Illustrated Parts List to identify and ensure that all parts are present.
2. Generally, check over unit to assure the tightness of all nuts, bolts and fittings.
3. With rams completely collapsed, check hydraulic fluid level.
 - Replenish with MIL-PRF-5606 fluid as required.
 - Fluid level is full when seen in sight glass.

NOTE: Refer to fluid manufacturer's (Appendix IV) safety data sheet, and advisory for handling and disposal of fluid.

4.3 PERSONNEL REQUIREMENTS:

This jack is to be assembled by qualified technicians familiar with hydraulic systems.

4.4 INSPECTION AND TEST PROCEDURES:

1. Ensure fluid level is within sight glass.
2. Raise ram to full stroke, and check for leaks.

5.0 INSTALLATION

Installation and commissioning requires connection of the hold to run air valve to an adequate air supply (Air Pump Equipped Models Only).

5.1 AIR SUPPLY REQUIREMENTS:

90 - 100 psi (6.21 - 6.89 bar) recommended

6.0 OPERATION

6.1 OPERATING PARAMETERS:

- The user shall work in accordance with the Operator Manual
- It is not allowed to work under the raised load until it is secured by suitable means, i.e. Ram Locknut
- The employer of the operator shall provide for all necessary training and give information about pumping and translating forces
- Operate between -20° C and 50°C/-4° F and 122° F
- Hydraulic pump operates with 90 – 100 psi (6.21 – 6.89 bar) air pressure

6.2 NUMERICAL VALUES

Rated Capacity	30,000 lbs (13,607 kg)
Minimum Closed Height	20 in (50.8 cm)
Mechanical Extension	4 in (10.2 cm)
Hydraulic Extension 1st Stage	11.16 in (28.3 cm)
Hydraulic Extension 2nd Stage	11.94 in (30.3 cm)
Hydraulic Extension 3rd Stage	12.59 in (31.9 cm)
Maximum Height Obtainable	59 in (149.9 cm)
Weight	390 lbs (177 kg)
Noise level is 64 dB(A) at a distance of 120 in (3,048 mm) at an inlet pressure of 100 psi (6.9 bar)	

6.3 OPERATOR CONTROLS

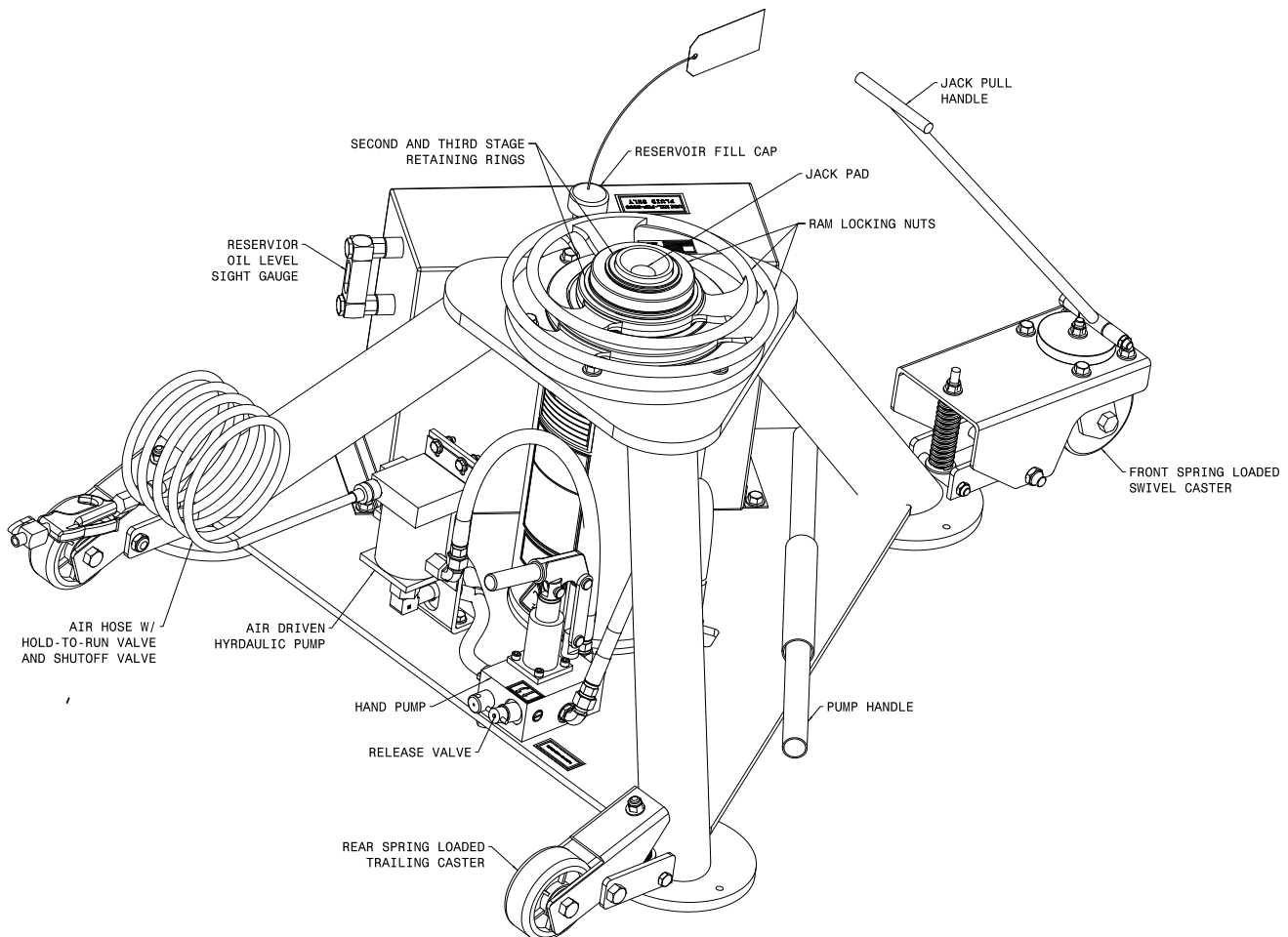

6.4 OPERATING INSTRUCTIONS

The user should be familiar with the following statements prior to using the jack(s):



CAUTION!

1. **Never put hands between the aircraft and the jack pad; as after aircraft has been lowered, struts may have hung up.**
2. **Never align jack under aircraft by pounding on jack legs. Dented legs may lead to jack collapse.**
3. **Always lower ram locking nut(s) after jack is under load. Be sure ram nut(s) is seated fully after jacking.**
4. **Always raise and lower jacks simultaneously so that aircraft remains level.**
5. **Always use a tail or nose stand, as applicable, for additional stability.**

6.4.1 Rules For Operating

1. The user shall work in accordance with the Operator and/or Technical Manuals.
2. It is not allowed to work under the raised load until it is secured by suitable means, i.e. Ram Locknut.
3. The employer of the operator shall provide for all necessary training and give information about pumping and translating forces.
4. Operate between -20° C and 50°C/-4° F and 122° F.
5. Hydraulic pump operates with 90 – 100 psi (6.21 – 6.89 bar) air pressure

6.4.2 Jack Instructions

To Raise Aircraft:

1. Place jack on a hard, level surface.
2. Hydraulic ram must be completely retracted before operating the jack.
3. Maneuver jack into jacking position.
4. Extend mechanical extension 2 to 3 inches.

NOTE: Mechanical extension has a built-in mechanical stop and is limited to a 4" travel

5. Close pump release valve clockwise and operate pump.
6. Hydraulic rams must extend in order from largest to smallest diameter.
7. Largest diameter hydraulic ram must fully extend before the next stage ram begins to raise.
8. Lower mechanical ram locknut(s) while extending rams. Keep within 1 inch of bottom of extending ram
9. Do not continue to operate air pump after all rams have fully extended.



WARNING!

The ram locknuts are user operated safety devices. Failure to utilize these locknuts may result in personal injury or death and/or damage to aircraft or equipment.

To Lower Aircraft:

1. Lower all jacks simultaneously.
2. If ram locknut(s) is tight, raise jack slightly to release nut(s) ¼ inch from tripod.
3. Ensure proper staging as aircraft is being lowered: loosen ram locknut beginning with smallest ram (1 inch max) until stage is completely lowered. Repeat for next smallest stage.
4. Loosen pump release valve slightly to slowly lower aircraft.
5. Remove jack from aircraft.

NOTE: When using jack during washing operations, completely cover top of jack near ram seal.

CAUTION!

Do not place hands on top of jack near ram locknuts while lowering jack. Pinch points exist between top of jack and threads on ram.



Always wear safety glasses.

7.0 PACKAGING AND STORAGE

7.1 PACKAGING REQUIREMENTS

Jacks are to be packaged as required to prevent damage to legs or hydraulic equipment during shipment.

7.2 HANDLING

Jacks can be rolled by hand on its casters.

7.3 STRAPPING

Jacks can be strapped down by suitable means to prevent unwanted movement during shipment.

7.4 PACKAGING PROTECTION

No special packaging material for cushioning or suspension is required.

7.5 LABELING OF PACKAGING

Packaging should be labeled DO NOT DROP.

7.6 STORAGE COMPATIBILITY

No special considerations.

7.7 STORAGE ENVIRONMENT

- Store jacks between -20°C and +50°C/-4° F and 122° F.
- Always store jack with ram all the way down.
- Suitable for outdoor storage by using a full coverage waterproof tarp or canvas.

7.8 STORAGE SPACE AND HANDLING FACILITIES

Minimum Closed Height20 in (50.8 cm)
Weight390 lbs (177 kg)

8.0 TRANSPORTATION

Lifting can be accomplished by crane and strap through top of tripod, or by fork truck under lower tripod support.
Approximate weight = 380 lbs (172 kg)

9.0 TROUBLE SHOOTING

TROUBLE	PROBABLE CAUSE	ACTION
Fluid leakage at pump piston or pump body	Damaged backup ring, o-ring, piston or pump body	Remove piston and pump body. Inspect for damage. Replace defective part(s). Replace removed o-ring and backup ring
External fluid leakage at ram(s)	Damaged o-ring, backup ring or inner cylinder wall	Remove ram(s) as a unit from cylinder. Inspect parts. Replace o-ring and defective part(s)
Jack fails to lift rated load	Release valve not closed properly	Fully tighten release valve
	Low fluid level	Fill to correct fluid level
	Pressure relief valve improperly adjusted	Adjust or replace release valve
	Leakage at inlet or outlet check ball	Inspect valve body for wear or replace valve body and check balls
	Vent screw closed	Open vent screw
Ram(s) will not support load after manual or pneumatic pump up	Leaking ram o-ring seals	Check for external leakage, if present replace defective seal and back up ring
	Leaking pressure check valve	Inspect valve body for wear or replace valve body and check balls
	Leaking pressure relief valve	Remove release valve, inspect ball and ball seat in pump block. Replace effective part(s)
Ram(s) raise and fall with each manual pump stroke	Release valve open	Fully tighten release valve
	Inlet check valve not seated or sticking	Pump rapidly to dislodge or replace valve body
	Pressure check valve not seated or sticking	Pump rapidly to dislodge or replace valve body
Jack fails to lower	Ram locknut not loosened	Raise jack ¼ inch and release locknut
	Vent screw closed	Open vent screw
	O-Ring (pinched or rolled)	Replace o-ring and back-up ring, clean up cylinder wall of debris

10.0 MAINTENANCE

10.1 GENERAL

- All maintenance and/or repair work should be done using good workmanship practices and proper tools.
- The work area should be clean and free of dirt.
- When O-rings and backup rings are removed, every effort should be made to avoid the contact of tools with the critical surfaces of parts. Surface deformities could cause degradation of seals and failure.
- It is good practice to replace both O-rings and backup rings once removed. Cut and damaged rings normally result in fluid leakage.
- At this time flush old hydraulic fluid and dirt from over-all system and replenish with new, clean hydraulic fluid.
- No modifications shall be carried out without prior written approval by Tronair.

10.2 MAINTENANCE SCHEDULE

Check Fluid Level.....	Each Use
Lubricate Casters	3 Months
Cleaning.....	Annually Or As Needed
Capacity Test (105%-110% of jack's rated capacity)	Annually

NOTE: Wipe with soft cloth only, do no pressure wash or spray water directly at ram seal.

10.2.1 Storage/Low Usage

If jack is not being used on a regular basis, every 90 days the jack should be fully extended and retracted to exercise the seals and to prevent rust build up on the cylinder I.D. While ram is extended, clean the threads and spray with DoALL RPM, LPS, or equivalent that is water repellent and will not harm BUNA "N" O-rings.

10.3 SERVICING JACK

To Disassemble Jack For Seal Replacement:

1. Raise first stage ram high enough to allow removal of the threaded tube stop.
2. Raise all rams **together** to the point where this assembly can be lifted from the jack cylinder.

NOTE: If the second and third stage rams are allowed to precede the first stage ram, it will fill with oil causing an oil spill when the assembly is removed from the cylinder.

To Re-assemble Jack:

1. Re-assemble in reverse order of above.

NOTE: Lubricate cylinder, ram(s) and o-ring(s) for assembly:

Lubricate inner cylinder wall(s) with MIL-PRF-5606 hydraulic fluid

Apply suitable o-ring lubricant grease to installed o-ring(s) and to o-ring lead-in chamfer at opening of cylinder

NOTE: To minimize air entrapment under the rams. Actuate cylinder with had pump several inches and release. This will circulate oil and bleed out air.

2. Spray I.D. of cylinder and O.D. of rams with DoALL RPM, LPS or equivalent water repellent that will not harm the Buna "N" O-rings to protect surfaces from rusting when not in use.
3. Ensure locknut retaining ring is present on second and third stage rams to prevent nut removal after seal kit installation.

10.4 JACK FUNCTION LOAD TEST

NOTE: If function load testing is required:

1. Take all necessary precautions to prevent injury.
2. Always jack against a load and **never** against the jack itself.
3. Do not exceed a test load equal to the jack rated capacity plus 5% to 10%.

10.5 PNEUMATIC PUMP

See Haskel Air Pump Manufacturer Data for complete parts list and repair information.

11.0 PROVISION OF SPARES

11.1 SOURCE OF SPARE PARTS

Spare parts may be obtained from the manufacturer:

TRONAIR, Inc.

1 Air Cargo Pkwy East

Swanton, Ohio 43558 USA

Telephone: (419) 866-6301 or 800-426-6301

Fax: (419) 867-0634

E-mail: sales@tronair.com

Website: www.tronair.com



For Spare Parts, Operations & Service Manuals or Service Needs:

Scan the QR code or visit Tronair.com/aftermarket

11.2 RECOMMENDED SPARE PARTS LISTS

Reference the following page(s) for Replacement Parts and Kits available.

12.0 IN SERVICE SUPPORT

Contact Tronair, Inc. for technical services and information. See Section 1.3 – Manufacturer.

13.0 GUARANTEES/LIMITATION OF LIABILITY

Tronair products are warranted to be free of manufacturing or material defects for a period of one year after shipment to the original customer. This is solely limited to the repair or replacement of defective components. This warranty does not cover the following items:

- a) Parts required for normal maintenance
- b) Parts covered by a component manufacturers warranty
- c) Replacement parts have a 90-day warranty from date of shipment

If you have a problem that may require service, contact Tronair immediately. Do not attempt to repair or disassemble a product without first contacting Tronair, any action may affect warranty coverage. When you contact Tronair be prepared to provide the following information:

- a) Product Model Number
- b) Product Serial Number
- c) Description of the problem

If warranty coverage is approved, either replacement parts will be sent or the product will have to be returned to Tronair for repairs. If the product is to be returned, a Return Material Authorization (RMA) number will be issued for reference purposes on any shipping documents. Failure to obtain a RMA in advance of returning an item will result in a service fee. A decision on the extent of warranty coverage on returned products is reserved pending inspection at Tronair. Any shipments to Tronair must be shipped freight prepaid. Freight costs on shipments to customers will be paid by Tronair on any warranty claims only. Any unauthorized modification of the Tronair products or use of the Tronair products in violation of cautions and warnings in any manual (including updates) or safety bulletins published or delivered by Tronair will immediately void any warranty, express or implied.

The obligations of Tronair expressly stated herein are in lieu of all other warranties or conditions expressed or implied. **Any unauthorized modification of the Tronair products or use of the Tronair products in violations of cautions and warnings in any manual (including updates) or safety bulletins published or delivered by Tronair will immediately void any warranty, express or implied and Tronair disclaims any and all liability for injury (WITHOUT LIMITATION and including DEATH), loss or damage arising from or relating to such misuse.**

14.0 APPENDICES

- APPENDIX I Hydraulic Schematic
- APPENDIX II HC-1961 Hand Pump Parts List
- APPENDIX III Declaration of Conformity
- APPENDIX IV Safety Data Sheet – MIL-PRF-5606 Hydraulic Fluid
- APPENDIX V Maintenance Schedule

Parts List

When ordering replacement parts/kits, please specify model, serial number and color of your unit.

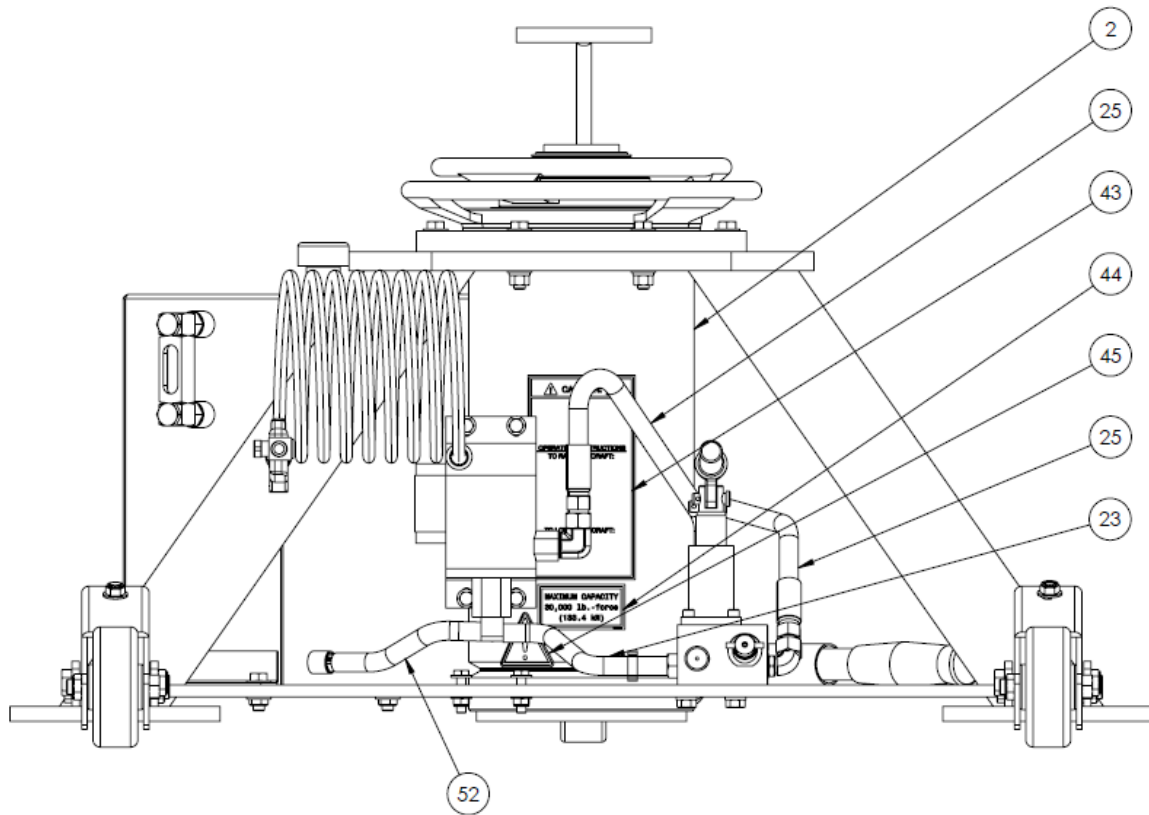
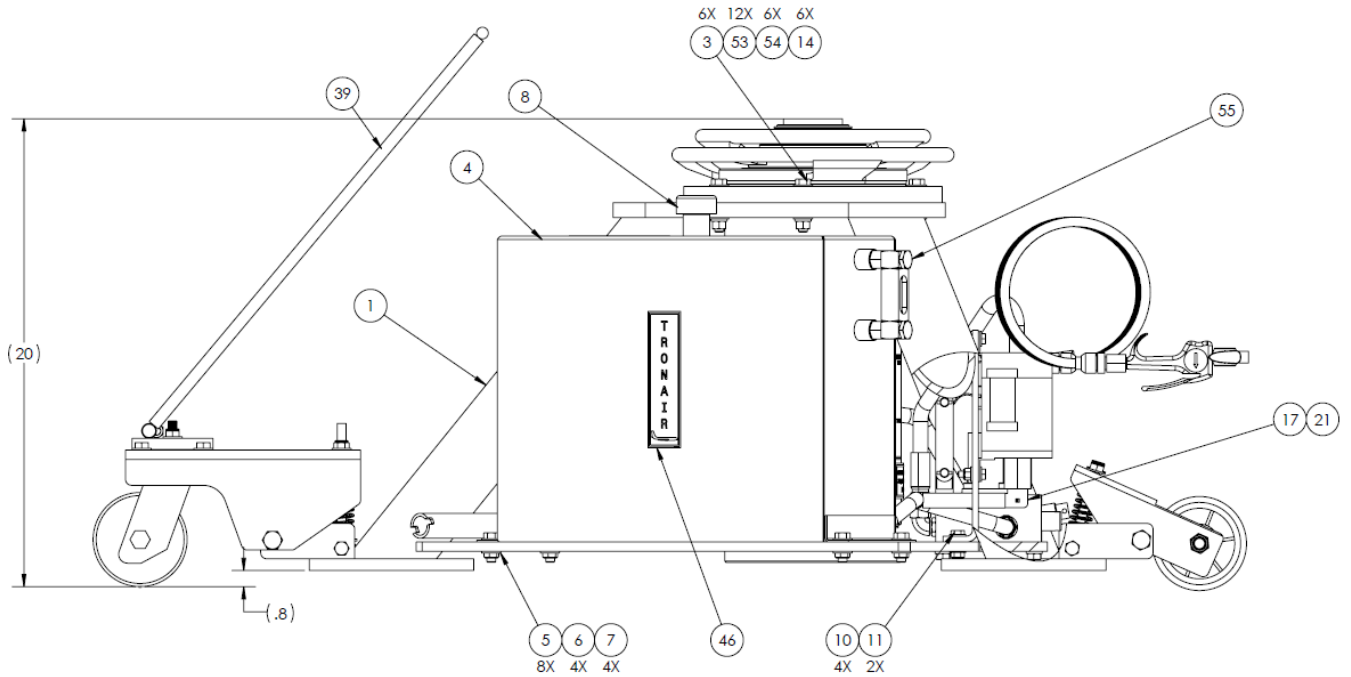

Parts List

When ordering replacement parts/kits, please specify model, serial number and color of your unit.

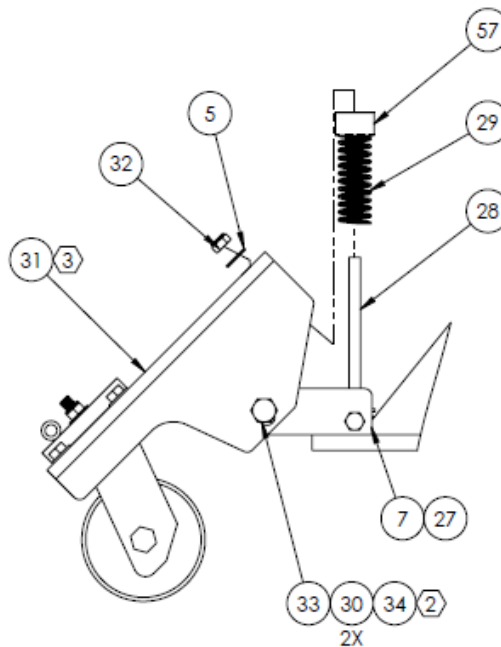
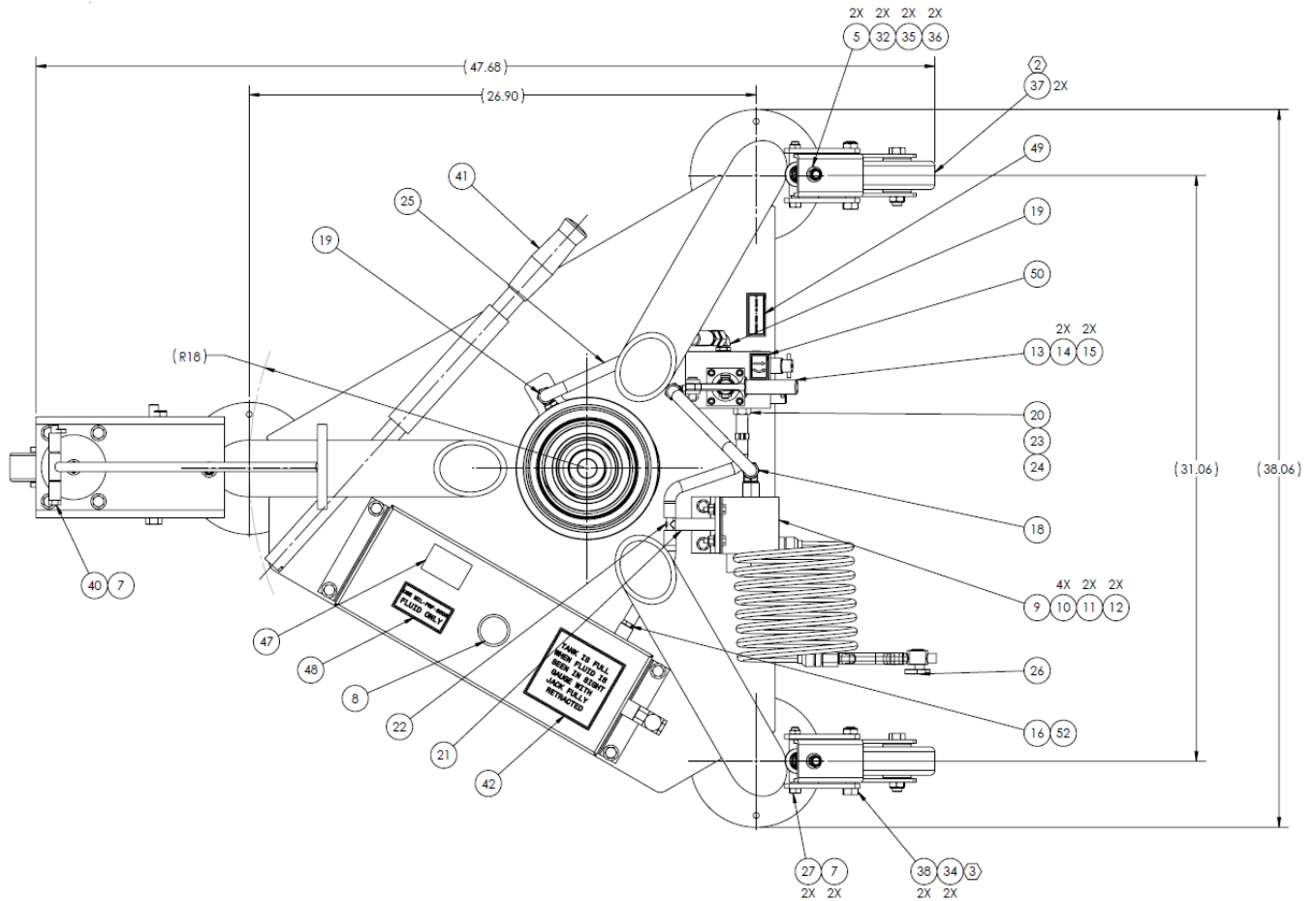

Parts List

When ordering replacement parts/kits, please specify model, serial number and color of your unit.

Item	Part Number	Description	Qty
1	Z-7815-00	WELDMENT, JACK	1
2	Z-7801	ASSEMBLY, RAM	1
3	G-1100-107020	BOLT, 3/8-16 X 2.0" HEX HD GR 5	6
4	Z-7819-01	RESERVOIR	1
5	G-1250-1070N	FLATWASHER, 3/8 NARROW	11
6	G-1100-107510	BOLT, 3/8-24 X 1.0" HEX HD GR 5	4
7	G-1203-1075	JAMNUT, 3/8-24 ELASTIC	8
8	H-1045	BREATHER	1
9	Z-7154-01	ASSEMBLY, AIR PUMP	1
10	G-1250-1060N	FLATWASHER, 5/16 NARROW	4
11	G-1100-106512	BOLT, 5/16-24 X 1-1/4" LG. HEX HD GR 5	2
12	G-1202-1065	STOPNUT, 5/16-24 ELASTIC	2
13	HC-1961	PUMP, HYD HAND CE (3250 PSI)	1
14	G-1251-1070R	LOCKWASHER, 3/8 REGULAR	8
15	G-1100-107010	BOLT, 3/8-16 X 1.0" HEX HD GR 5	2
16	N-2412-10	CONNECTOR, STRAIGHT MALE	1
17	N-2410-05	ELBOW, 90° MALE 3/8 BARB X 3/8 NPT	1
18	N-2005-08-S	ELBOW, MALE #6 JIC X 1/4 NPT	1
19	N-2001-08-S-B	ELBOW, STRAIGHT THREAD	3
20	N-2789-04-S-B	CONNECTOR, MALE STR THD BD HSE	1
21	TF-1047-04-3.5	HOSE, 3/8 GRAY	1
22	N-2453-04	TEE, NYLON UNION 3/8 BARB	1
23	TF-1047-04-07.0	HOSE, PUSH ON MINERAL BASE GRAY	1
24	H-1516-11	CLAMP, 2-EAR HOSE	1
25	TF-1043-06-18.0	ASSEMBLY, HOSE	2
26	Z-4973	ASSEMBLY, BLOWGUN	1
27	G-1100-107532	BOLT, 3/8-24 X 3-1/4" HEX HD GR 5	3
28	Z-6588	WELDMENT, PIVOT	1
29	H-2210-08	SPRING, COMPRESSION	1
30	TR378-03-001.00	TBG, SST .625OD-049W	2
31	Z-6587	ASSEMBLY, FRONT WHEEL	1
32	G-1202-1075	STOPNUT, 3/8-24 ELASTIC	3
33	G-1100-109560	BOLT, 1/2-20 X 6.0" HEX HD GR 5	1
34	G-1203-1095	JAMNUT, 1/2-20 ELASTIC	3
35	Z-2302	WELDMENT, PIVOT	2
36	H-3398-07	SPRING, COMPRESSION	2
37	Z-2322	ASSEMBLY, REAR WHEEL	2
38	G-1100-109532	BOLT, 1/2-20 X 3-1/4" HEX HD GR 5	2
39	Z-2301-01	WELDMENT, HANDLE	1
40	G-1100-107540	BOLT, 3/8-24 X 4.0" HEX HD GR 5	1
41	H-1009-01	ASSEMBLY, HANDLE	1
42	V-2163	LABEL, FULL TANK	1
43	V-2105	LABEL, JACKING INSTRUCTIONS	1
44	V-2112	LABEL MAX, CAPACITY	1
45	V-1805	LABEL, ISO GENERAL DANGER	1

Parts List

When ordering replacement parts/kits, please specify model, serial number and color of your unit.

Item	Part Number	Description	Qty
46	V-1198	LABEL, TRONAIR	1
47	V-1001	LABEL, MADE IN USA	1
48	V-1102	LABEL, MIL-PRF-5606	1
49	V-1775	LABEL, PUMP FORCE	1
50	V-1776	LABEL, DOWN	1
52	TF-1047-04-06.0	HOSE, 3/8" GRAY	1
53	G-1513-1070N	FLATWASHER, 3/8 THRU HARD	12
54	G-1200-1070	NUT, 3/8-16 HEX	6
55	HC-2338	GAUGE, LIQUID LEVEL	1
N/S	N-2212-05-S	PLUG, SQUARE HEAD	1
N/S	R-2680	PLUG, SQUARE HEAD	1
N/S	K-1685	AIR PUMP SEAL KIT (HYDRAULIC)	1
N/S	K-1686	AIR PUMP SEAL KIT (PNEUMATIC)	1

Parts List

When ordering replacement parts/kits, please specify model, serial number and color of your unit.

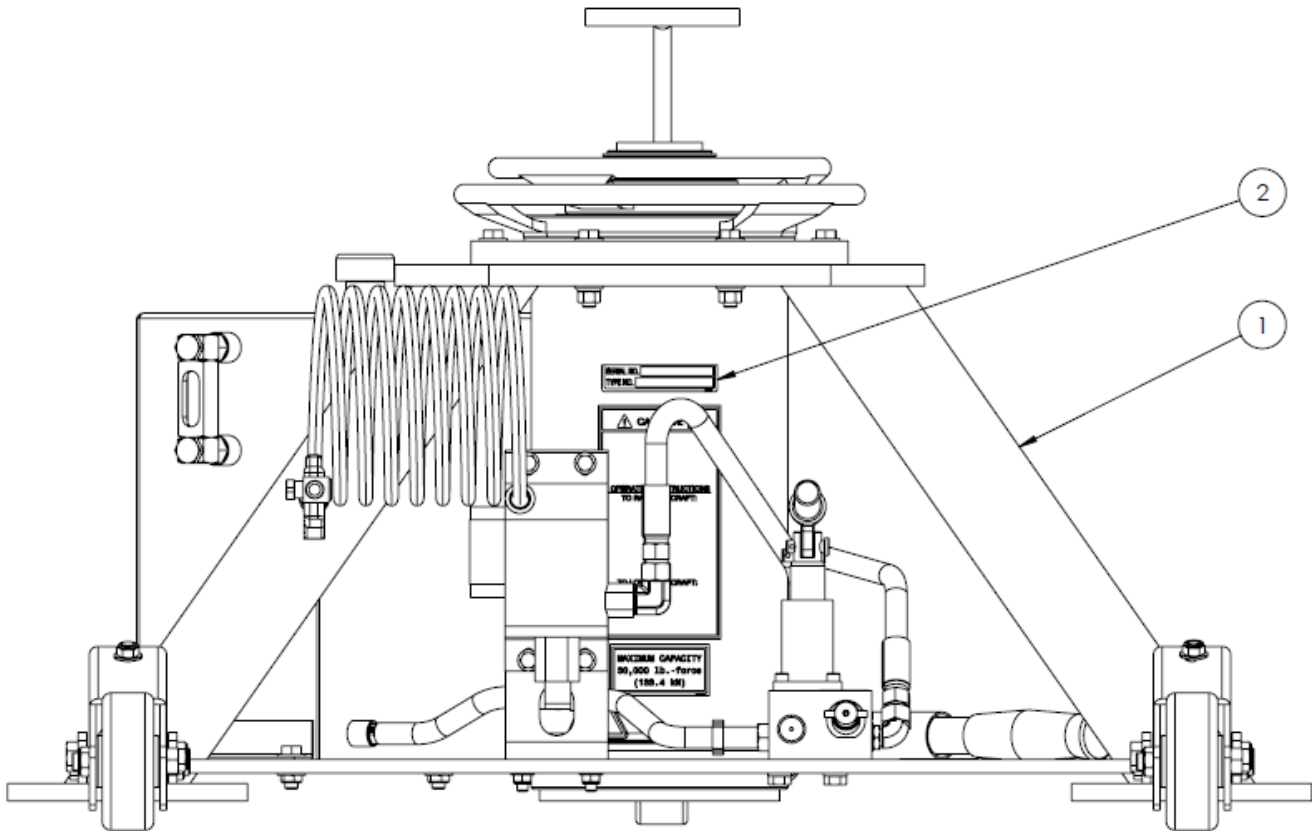

Item	Part Number	Description	Z-10965-A1
1	Z-10963-81	BASE ASSEMBLY, JACK 5 TON "CE"	1
2	V-2972	LABEL, JACK TYPE/SERIAL	1



APPENDIX I

Hydraulic Schematic

Hydraulic Schematic

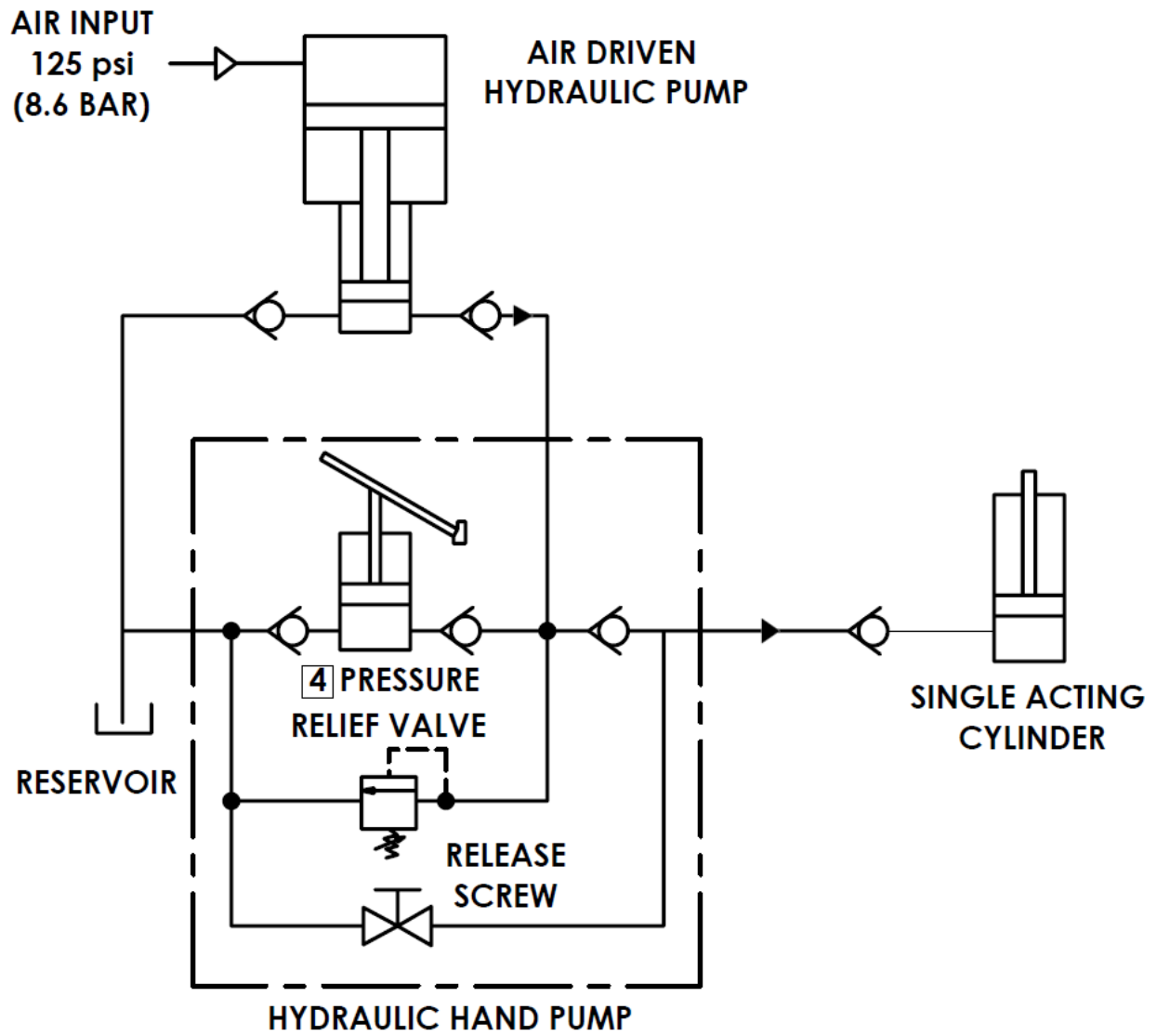



APPENDIX II

**HC-1961
Hand Pump Parts List**



**Model: HC-1961
3250 psi Hand Pump**

**Parts List
With Illustrations**

05/2005 – Rev. OR

This product can not be modified without the written approval of Tronair, Inc. Any modifications done without written approval voids all warranties and releases Tronair, Inc., its suppliers, distributors, employees, or financial institutions from any liability from consequences that may occur.

This pump is compatible with MIL-PRF-5606/MIL-H-83282 Hydraulic Fluids only.

INSTALLATION INSTRUCTIONS:

1. Inspect all parts. Replace all worn or otherwise defective parts.
2. Clean all parts prior to re-assembly.
3. Lubricate all O-rings with clean system hydraulic fluid prior to installation.
4. Torque pump screws (Item 4) to 10 ft-lbs.

Parts List

When ordering Replacement Parts/Kits, please specify Model and Serial Number of your Unit.

Reference Illustrations on following page

Item	Part Number	Description	Qty
4	518-000	Screw, Socket Head Cap	4
9	Not Sold Separately	Pump Body	1
10	H-2606	Assembly, Relief Screw	1
24	506-000	Flange Half	4
Not Shown	H-1009-01	Handle	1
	K-1068	Kit, Linkage Replacement; consists of:	
17		Bracket, Pump Handle	1
18		Assembly, Clevis Pin	1
19		Assembly, Linkage Pin	2
20		Strap	2
23		Pivot	1
	K-1778	Kit, Piston/Cylinder Replacement; consists of:	
1		Retainer, Wiper	1
21		Tube	1
22		Piston	1
25		Assembly, Valve Body (Includes Items 7, 12, 25, 26)	1
	K-1906	Kit, Piston/Seal Replacement; consists of:	
3		Ring, Backup	1
5		O-ring, Piston	1
22		Piston	1
	K-3342	Kit, Internal Parts Replacement; consists of:	
12		Spring, Inlet Check	1
26		Ball, Inlet Check	2
28		Ball, Outlet Check	1
29		Spring, Outlet Check	1
33		Spring, Inlet Check	1
	K-3343	Kit, Release Screw Replacement; consists of:	
13		Screw, Release	1
14		Pin, Roll	1
15		Retainer, Screw	1
16		O-ring	1
	K-3441	Kit, Seal Replacement; consists of:	
2		Wiper, Rod	1
3		Ring, Backup	1
5		O-ring, Piston	1
6		O-ring, Valve Body	1
8		O-ring, Tube Seal	1
11		O-ring, Relief Screw	1
16		O-ring, Release Screw	1
27		O-ring, Outlet Check	1
34		Ring, Backup Relief Screw	1
35		O-ring, Relief Screw	1

Parts List Illustrations

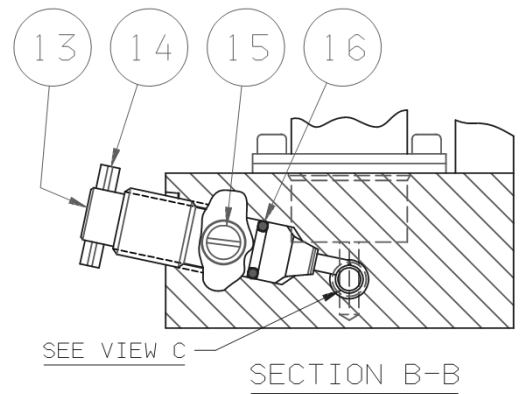
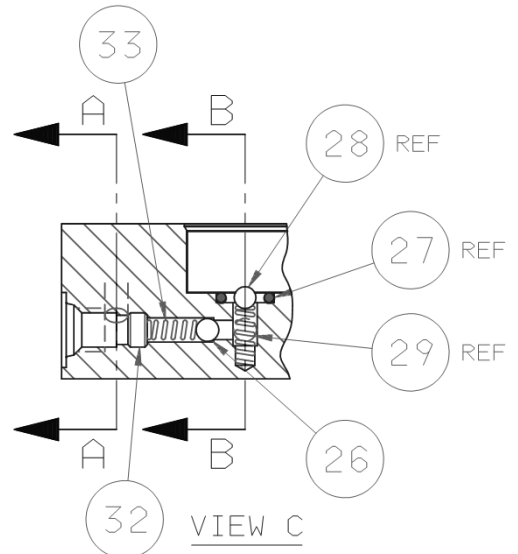
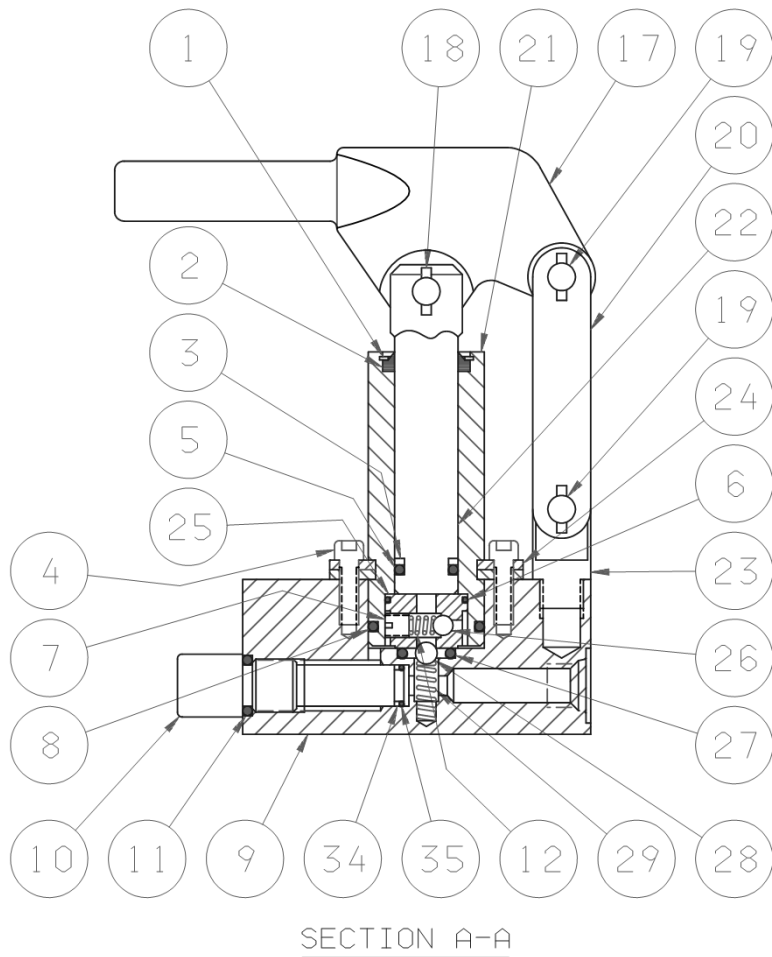

WARNING!

Item 10 (H-2606) is a preset relief valve. Do Not disassemble this valve.
Replacement parts are available as a preset relief valve assembly



APPENDIX III

Declaration of Conformity



DECLARATION of CONFORMITY

The design, development and manufacture is in accordance with European Community guidelines

Tripod Jack
02A7912C0100
02A7917C0100

Relevant provisions complied with by the machinery:
2006/42/EC

Relevant standards complied with by the machinery:
EN ISO 12100-1

Identification of person empowered to sign on behalf of the Manufacturer:

A handwritten signature in cursive script that reads "Patrick Finch". The signature is written in black ink and is positioned above a horizontal line.

Quality Assurance Representative



APPENDIX IV

Safety Data Sheet MIL-PRF-5606 Hydraulic Fluid

SAFETY DATA SHEET

SECTION 1 PRODUCT AND COMPANY IDENTIFICATION**PRODUCT**

Product Name: MOBIL AERO HFA
Product Description: Base Oil and Additives
Product Code: 201550401020, 490110-00, 970584
Intended Use: Aviation hydraulic oil

COMPANY IDENTIFICATION

Supplier: EXXON MOBIL CORPORATION
22777 Springwoods Village Parkway
Spring, TX. 77253 USA
24 Hour Health Emergency 609-737-4411
Transportation Emergency Phone 800-424-9300 or 703-527-3887 CHEMTREC
Product Technical Information 800-662-4525
MSDS Internet Address <http://www.exxon.com>, <http://www.mobil.com>

SECTION 2 HAZARDS IDENTIFICATION

This material is hazardous according to regulatory guidelines (see (M)SDS Section 15).

CLASSIFICATION:

Flammable liquid: Category 4.
Aspiration toxicant: Category 1.

LABEL:

Pictogram:



Signal Word: Danger

Hazard Statements:

H227: Combustible liquid. H304: May be fatal if swallowed and enters airways.

Precautionary Statements:

P210: Keep away from flames and hot surfaces. -- No smoking. P273: Avoid release to the environment. P280: Wear protective gloves and eye / face protection. P301 + P310: IF SWALLOWED: Immediately call a POISON CENTER or doctor/physician. P331: Do NOT induce vomiting. P370 + P378: In case of fire: Use water fog, foam, dry chemical or carbon dioxide (CO2) to extinguish. P403 + P235: Store in a well-ventilated place. Keep cool. P405: Store locked up. P501: Dispose of contents and container in accordance with local regulations.

Product Name: MOBIL AERO HFA
 Revision Date: 01 Oct 2015
 Page 2 of 12

Other hazard information:

HAZARD NOT OTHERWISE CLASSIFIED (HNOC): None as defined under 29 CFR 1910.1200.

PHYSICAL / CHEMICAL HAZARDS

Material can accumulate static charges which may cause an ignition. Material can release vapors that readily form flammable mixtures. Vapor accumulation could flash and/or explode if ignited. Combustible.

HEALTH HAZARDS

High-pressure injection under skin may cause serious damage. Excessive exposure may result in eye, skin, or respiratory irritation.

ENVIRONMENTAL HAZARDS

No significant hazards.

NFPA Hazard ID: Health: 1 Flammability: 2 Reactivity: 0
HMIS Hazard ID: Health: 1* Flammability: 2 Reactivity: 0

NOTE: This material should not be used for any other purpose than the intended use in Section 1 without expert advice. Health studies have shown that chemical exposure may cause potential human health risks which may vary from person to person.

SECTION 3 COMPOSITION / INFORMATION ON INGREDIENTS

This material is defined as a mixture.

Hazardous Substance(s) or Complex Substance(s) required for disclosure

Name	CAS#	Concentration*	GHS Hazard Codes
2,6-DI-TERT-BUTYL-P-CRESOL	128-37-0	0.1 - < 1%	H400(M factor 1), H410(M factor 1)
DISTILLATES (PETROLEUM), HYDROTREATED LIGHT	64742-47-8	5 - < 10%	H304
HYDROTREATED LIGHT NAPHTHENIC DISTILLATE (PETROLEUM)	64742-53-6	50 - < 70%	H227, H304
HYDROTREATED MIDDLE DISTILLATE (PETROLEUM)	64742-46-7	20 - < 30%	H304
TRIPHENYL PHOSPHATE	115-86-6	0.1 - < 0.25%	H400(M factor 1), H410(M factor 1)

* All concentrations are percent by weight unless material is a gas. Gas concentrations are in percent by volume.

As per paragraph (i) of 29 CFR 1910.1200, formulation is considered a trade secret and specific chemical identity and exact percentage (concentration) of composition may have been withheld. Specific chemical identity and exact percentage composition will be provided to health professionals, employees, or designated representatives in accordance with applicable provisions of paragraph (i).

SECTION 4 FIRST AID MEASURES

INHALATION

Product Name: MOBIL AERO HFA

Revision Date: 01 Oct 2015

Page 3 of 12

Remove from further exposure. For those providing assistance, avoid exposure to yourself or others. Use adequate respiratory protection. If respiratory irritation, dizziness, nausea, or unconsciousness occurs, seek immediate medical assistance. If breathing has stopped, assist ventilation with a mechanical device or use mouth-to-mouth resuscitation.

SKIN CONTACT

Wash contact areas with soap and water. Remove contaminated clothing. Launder contaminated clothing before reuse. If product is injected into or under the skin, or into any part of the body, regardless of the appearance of the wound or its size, the individual should be evaluated immediately by a physician as a surgical emergency. Even though initial symptoms from high pressure injection may be minimal or absent, early surgical treatment within the first few hours may significantly reduce the ultimate extent of injury.

EYE CONTACT

Flush thoroughly with water. If irritation occurs, get medical assistance.

INGESTION

Seek immediate medical attention. Do not induce vomiting.

NOTE TO PHYSICIAN

If ingested, material may be aspirated into the lungs and cause chemical pneumonitis. Treat appropriately.

SECTION 5 FIRE FIGHTING MEASURES

EXTINGUISHING MEDIA

Appropriate Extinguishing Media: Use water fog, foam, dry chemical or carbon dioxide (CO₂) to extinguish flames.

Inappropriate Extinguishing Media: Straight Streams of Water

FIRE FIGHTING

Fire Fighting Instructions: Evacuate area. Prevent runoff from fire control or dilution from entering streams, sewers, or drinking water supply. Firefighters should use standard protective equipment and in enclosed spaces, self-contained breathing apparatus (SCBA). Use water spray to cool fire exposed surfaces and to protect personnel.

Unusual Fire Hazards: Combustible. Pressurized mists may form a flammable mixture.

Hazardous Combustion Products: Aldehydes, Incomplete combustion products, Oxides of carbon, Phosphorus oxides, Smoke, Fume, Sulfur oxides

FLAMMABILITY PROPERTIES

Flash Point [Method]: >82°C (180°F) [ASTM D-93]

Flammable Limits (Approximate volume % in air): LEL: 0.7 UEL: 7.0 [Estimated]

Autoignition Temperature: >225°C (437°F)

SECTION 6 ACCIDENTAL RELEASE MEASURES

NOTIFICATION PROCEDURES

In the event of a spill or accidental release, notify relevant authorities in accordance with all applicable

Product Name: MOBIL AERO HFA

Revision Date: 01 Oct 2015

Page 4 of 12

regulations. US regulations require reporting releases of this material to the environment which exceed the applicable reportable quantity or oil spills which could reach any waterway including intermittent dry creeks. The National Response Center can be reached at (800)424-8802.

PROTECTIVE MEASURES

Avoid contact with spilled material. Warn or evacuate occupants in surrounding and downwind areas if required due to toxicity or flammability of the material. See Section 5 for fire fighting information. See the Hazard Identification Section for Significant Hazards. See Section 4 for First Aid Advice. See Section 8 for advice on the minimum requirements for personal protective equipment. Additional protective measures may be necessary, depending on the specific circumstances and/or the expert judgment of the emergency responders.

For emergency responders: Respiratory protection: respiratory protection will be necessary only in special cases, e.g., formation of mists. Half-face or full-face respirator with filter(s) for dust/organic vapor or Self Contained Breathing Apparatus (SCBA) can be used depending on the size of spill and potential level of exposure. If the exposure cannot be completely characterized or an oxygen deficient atmosphere is possible or anticipated, SCBA is recommended. Work gloves that are resistant to hydrocarbons are recommended. Gloves made of polyvinyl acetate (PVA) are not water-resistant and are not suitable for emergency use. Chemical goggles are recommended if splashes or contact with eyes is possible. Small spills: normal antistatic work clothes are usually adequate. Large spills: full body suit of chemical resistant, antistatic material is recommended.

SPILL MANAGEMENT

Land Spill: Eliminate all ignition sources (no smoking, flares, sparks or flames in immediate area). Stop leak if you can do it without risk. All equipment used when handling the product must be grounded. Do not touch or walk through spilled material. Prevent entry into waterways, sewer, basements or confined areas. A vapor suppressing foam may be used to reduce vapors. Use clean non-sparking tools to collect absorbed material. Absorb or cover with dry earth, sand or other non-combustible material and transfer to containers. Large Spills: Water spray may reduce vapor; but may not prevent ignition in closed spaces. Recover by pumping or with suitable absorbent.

Water Spill: Stop leak if you can do it without risk. Confine the spill immediately with booms. Warn other shipping. Remove from the surface by skimming or with suitable absorbents. Seek the advice of a specialist before using dispersants.

Water spill and land spill recommendations are based on the most likely spill scenario for this material; however, geographic conditions, wind, temperature, (and in the case of a water spill) wave and current direction and speed may greatly influence the appropriate action to be taken. For this reason, local experts should be consulted. Note: Local regulations may prescribe or limit action to be taken.

ENVIRONMENTAL PRECAUTIONS

Large Spills: Dike far ahead of liquid spill for later recovery and disposal. Prevent entry into waterways, sewers, basements or confined areas.

SECTION 7 HANDLING AND STORAGE

HANDLING

Avoid contact with skin. Avoid prolonged breathing of mists and heated vapor. Prevent small spills and leakage to avoid slip hazard. Material can accumulate static charges which may cause an electrical spark (ignition source). When the material is handled in bulk, an electrical spark could ignite any flammable vapors from liquids or residues that may be present (e.g., during switch-loading operations). Use proper bonding and/or ground procedures. However, bonding and grounds may not eliminate the hazard from static

Product Name: MOBIL AERO HFA

Revision Date: 01 Oct 2015

Page 5 of 12

accumulation. Consult local applicable standards for guidance. Additional references include American Petroleum Institute 2003 (Protection Against Ignitions Arising out of Static, Lightning and Stray Currents) or National Fire Protection Agency 77 (Recommended Practice on Static Electricity) or CENELEC CLC/TR 50404 (Electrostatics - Code of practice for the avoidance of hazards due to static electricity).

Static Accumulator: This material is a static accumulator.

STORAGE

The container choice, for example storage vessel, may effect static accumulation and dissipation. Keep container closed. Handle containers with care. Open slowly in order to control possible pressure release. Store in a cool, well-ventilated area. Storage containers should be grounded and bonded. Fixed storage containers, transfer containers and associated equipment should be grounded and bonded to prevent accumulation of static charge.

SECTION 8 EXPOSURE CONTROLS / PERSONAL PROTECTION

EXPOSURE LIMIT VALUES

Exposure limits/standards (Note: Exposure limits are not additive)

Substance Name	Form	Limit / Standard		NOTE	Source
2,6-DI-TERT-BUTYL-P-CRESOL	Inhalable fraction and vapor	TWA	2 mg/m ³	N/A	ACGIH
DISTILLATES (PETROLEUM), HYDROTREATED LIGHT [total hydrocarbon vapor]	Non-Aerosol	TWA	200 mg/m ³	Skin	ACGIH
HYDROTREATED LIGHT NAPHTHENIC DISTILLATE (PETROLEUM)	Mist.	TWA	5 mg/m ³	N/A	OSHA Z1
HYDROTREATED LIGHT NAPHTHENIC DISTILLATE (PETROLEUM)	Inhalable fraction.	TWA	5 mg/m ³	N/A	ACGIH
HYDROTREATED LIGHT NAPHTHENIC DISTILLATE (PETROLEUM)	Mist.	TWA	5 mg/m ³	N/A	ACGIH
HYDROTREATED MIDDLE DISTILLATE (PETROLEUM)	Mist.	TWA	5 mg/m ³	N/A	OSHA Z1
HYDROTREATED MIDDLE DISTILLATE (PETROLEUM)	Inhalable fraction.	TWA	5 mg/m ³	N/A	ACGIH
TRIPHENYL PHOSPHATE		TWA	3 mg/m ³	N/A	OSHA Z1
TRIPHENYL PHOSPHATE		TWA	3 mg/m ³	N/A	ACGIH

Exposure limits/standards for materials that can be formed when handling this product: When mists/aerosols can occur the following are recommended: 5 mg/m³ - ACGIH TLV (inhalable fraction), 5 mg/m³ - OSHA PEL.

NOTE: Limits/standards shown for guidance only. Follow applicable regulations.

No biological limits allocated.

ENGINEERING CONTROLS

The level of protection and types of controls necessary will vary depending upon potential exposure conditions.

Control measures to consider:
Use explosion-proof ventilation equipment to stay below exposure limits.

PERSONAL PROTECTION

Personal protective equipment selections vary based on potential exposure conditions such as applications, handling practices, concentration and ventilation. Information on the selection of protective equipment for use with this material, as provided below, is based upon intended, normal usage.

Respiratory Protection: If engineering controls do not maintain airborne contaminant concentrations at a level which is adequate to protect worker health, an approved respirator may be appropriate. Respirator selection, use, and maintenance must be in accordance with regulatory requirements, if applicable. Types of respirators to be considered for this material include:

No special requirements under ordinary conditions of use and with adequate ventilation.

For high airborne concentrations, use an approved supplied-air respirator, operated in positive pressure mode. Supplied air respirators with an escape bottle may be appropriate when oxygen levels are inadequate, gas/vapor warning properties are poor, or if air purifying filter capacity/rating may be exceeded.

Hand Protection: Any specific glove information provided is based on published literature and glove manufacturer data. Glove suitability and breakthrough time will differ depending on the specific use conditions. Contact the glove manufacturer for specific advice on glove selection and breakthrough times for your use conditions. Inspect and replace worn or damaged gloves. The types of gloves to be considered for this material include:

If prolonged or repeated contact is likely, chemical resistant gloves are recommended. If contact with forearms is likely, wear gauntlet style gloves.

Eye Protection: If contact is likely, safety glasses with side shields are recommended.

Skin and Body Protection: Any specific clothing information provided is based on published literature or manufacturer data. The types of clothing to be considered for this material include:

If prolonged or repeated contact is likely, chemical, and oil resistant clothing is recommended.

Specific Hygiene Measures: Always observe good personal hygiene measures, such as washing after handling the material and before eating, drinking, and/or smoking. Routinely wash work clothing and protective equipment to remove contaminants. Discard contaminated clothing and footwear that cannot be cleaned. Practice good housekeeping.

ENVIRONMENTAL CONTROLS

Comply with applicable environmental regulations limiting discharge to air, water and soil. Protect the environment by applying appropriate control measures to prevent or limit emissions.

SECTION 9

PHYSICAL AND CHEMICAL PROPERTIES

Note: Physical and chemical properties are provided for safety, health and environmental considerations only and may not fully represent product specifications. Contact the Supplier for additional information.

GENERAL INFORMATION

Physical State: Liquid
Color: Red

Product Name: MOBIL AERO HFA
 Revision Date: 01 Oct 2015
 Page 7 of 12

Odor: Characteristic
Odor Threshold: N/D

IMPORTANT HEALTH, SAFETY, AND ENVIRONMENTAL INFORMATION

Relative Density (at 15 °C): 0.88
Flammability (Solid, Gas): N/A
Flash Point [Method]: >82°C (180°F) [ASTM D-93]
Flammable Limits (Approximate volume % in air): LEL: 0.7 UEL: 7.0 [Estimated]
Autoignition Temperature: >225°C (437°F)
Boiling Point / Range: N/D
Decomposition Temperature: N/D
Vapor Density (Air = 1): N/D
Vapor Pressure: [N/D at 20 °C]
Evaporation Rate (n-butyl acetate = 1): N/D
pH: N/A
Log Pow (n-Octanol/Water Partition Coefficient): N/D
Solubility in Water: Negligible
Viscosity: 13.8 cSt (13.8 mm²/sec) at 40 °C | 5.1 cSt (5.1 mm²/sec) at 100°C [ASTM D 445]
Oxidizing Properties: See Hazards Identification Section.

OTHER INFORMATION

Freezing Point: N/D
Melting Point: N/A
Pour Point: -60°C (-76°F) [ASTM D97]
DMSO Extract (mineral oil only), IP-346: < 3 %wt

SECTION 10 STABILITY AND REACTIVITY

REACTIVITY: See sub-sections below.

STABILITY: Material is stable under normal conditions.

CONDITIONS TO AVOID: Open flames and high energy ignition sources.

MATERIALS TO AVOID: Strong oxidizers

HAZARDOUS DECOMPOSITION PRODUCTS: Material does not decompose at ambient temperatures.

POSSIBILITY OF HAZARDOUS REACTIONS: Hazardous polymerization will not occur.

SECTION 11 TOXICOLOGICAL INFORMATION

INFORMATION ON TOXICOLOGICAL EFFECTS

Hazard Class	Conclusion / Remarks
Inhalation	
Acute Toxicity: No end point data for material.	Minimally Toxic. Based on assessment of the components.
Irritation: No end point data for material.	Elevated temperatures or mechanical action may form vapors, mist, or fumes which may be irritating to the eyes, nose, throat, or lungs.

Product Name: MOBIL AERO HFA

Revision Date: 01 Oct 2015

Page 8 of 12

Ingestion	
Acute Toxicity: No end point data for material.	Minimally Toxic. Based on assessment of the components.
Skin	
Acute Toxicity: No end point data for material.	Minimally Toxic. Based on assessment of the components.
Skin Corrosion/Irritation: No end point data for material.	May dry the skin leading to discomfort and dermatitis. Based on assessment of the components.
Eye	
Serious Eye Damage/Irritation: No end point data for material.	May cause mild, short-lasting discomfort to eyes. Based on assessment of the components.
Sensitization	
Respiratory Sensitization: No end point data for material.	Not expected to be a respiratory sensitizer.
Skin Sensitization: No end point data for material.	Not expected to be a skin sensitizer. Based on assessment of the components.
Aspiration: Data available.	May be fatal if swallowed and enters airways. Based on physico-chemical properties of the material.
Germ Cell Mutagenicity: No end point data for material.	Not expected to be a germ cell mutagen. Based on assessment of the components.
Carcinogenicity: No end point data for material.	Not expected to cause cancer. Based on assessment of the components.
Reproductive Toxicity: No end point data for material.	Not expected to be a reproductive toxicant. Based on assessment of the components.
Lactation: No end point data for material.	Not expected to cause harm to breast-fed children.
Specific Target Organ Toxicity (STOT)	
Single Exposure: No end point data for material.	Not expected to cause organ damage from a single exposure.
Repeated Exposure: No end point data for material.	Not expected to cause organ damage from prolonged or repeated exposure. Based on assessment of the components.

TOXICITY FOR SUBSTANCES

NAME	ACUTE TOXICITY
2,6-DI-TERT-BUTYL-P-CRESOL	Oral Lethality: LD50 0.89 g/kg (Rat)

OTHER INFORMATION

For the product itself:

Repeated and/or prolonged exposure may cause irritation to the skin, eyes, or respiratory tract. Small amounts of liquid aspirated into the lungs during ingestion or from vomiting may cause chemical pneumonitis or pulmonary edema.

Contains:

Base oil severely refined: Not carcinogenic in animal studies. Representative material passes IP-346, Modified Ames test, and/or other screening tests. Dermal and inhalation studies showed minimal effects; lung non-specific infiltration of immune cells, oil deposition and minimal granuloma formation. Not sensitizing in test animals.

The following ingredients are cited on the lists below: None.

--REGULATORY LISTS SEARCHED--

Product Name: MOBIL AERO HFA
Revision Date: 01 Oct 2015
Page 9 of 12

1 = NTP CARC
2 = NTP SUS

3 = IARC 1
4 = IARC 2A

5 = IARC 2B
6 = OSHA CARC

SECTION 12 ECOLOGICAL INFORMATION

The information given is based on data available for the material, the components of the material, and similar materials.

ECOTOXICITY

Material -- Not expected to be harmful to aquatic organisms.

MOBILITY

More volatile component -- Highly volatile, will partition rapidly to air. Not expected to partition to sediment and wastewater solids.

Less volatile component -- Low solubility and floats and is expected to migrate from water to the land. Expected to partition to sediment and wastewater solids.

PERSISTENCE AND DEGRADABILITY

Biodegradation:

Components -- Expected to be inherently biodegradable

BIOACCUMULATION POTENTIAL

Majority of components -- Has the potential to bioaccumulate, however metabolism or physical properties may reduce the bioconcentration or limit bioavailability.

SECTION 13 DISPOSAL CONSIDERATIONS

Disposal recommendations based on material as supplied. Disposal must be in accordance with current applicable laws and regulations, and material characteristics at time of disposal.

DISPOSAL RECOMMENDATIONS

Product is suitable for burning in an enclosed controlled burner for fuel value or disposal by supervised incineration at very high temperatures to prevent formation of undesirable combustion products. Protect the environment. Dispose of used oil at designated sites. Minimize skin contact. Do not mix used oils with solvents, brake fluids or coolants.

REGULATORY DISPOSAL INFORMATION

RCRA Information: The unused product, in our opinion, is not specifically listed by the EPA as a hazardous waste (40 CFR, Part 261D), nor is it formulated to contain materials which are listed as hazardous wastes. It does not exhibit the hazardous characteristics of ignitability, corrosivity or reactivity and is not formulated with contaminants as determined by the Toxicity Characteristic Leaching Procedure (TCLP). However, used product may be regulated.

Empty Container Warning Empty Container Warning (where applicable): Empty containers may contain residue and can be dangerous. Do not attempt to refill or clean containers without proper instructions. Empty drums should be



APPENDIX V

Maintenance Schedule

Multi-Stage Tripod Jacks

Tronair recommends performing preventative maintenance on all jacks, which should include a 90-day routine inspection and a 12-month load test.

Model Number _____ Serial Number _____

Maintenance Performed By _____ Date _____

90-Day Maintenance:

- Check hydraulic system for leaks including the following:
 - Hydraulic lines; hoses and fittings
 - Hand pump; cylinder, fittings and seals
 - Reservoir; welds and fittings
 - Air operated pump (optional equipment); fittings, air side and oil side seals
- Check jack structure for corrosion, bending, cracking and excessive wear including the following:
 - Ball lock pins
 - Mechanical extension
 - Welded joints; tripod legs, cylinder and foot pads
 - Ram retaining rings
 - Ram lock nuts; gouge marks and cracks in threads
 - Jack pads
- Check fluid level with rams fully retracted. See manual or reservoir tag for proper level height
- Extend rams and visually inspect for corrosion, foreign matter, excessive wear and leaks around ram seals. Remove any foreign matter
- Check air operated pump if equipped (reference air operated pump service manual).
- Check paint condition, touch-up areas that are exposed
- Actuate the hand pump and raise the ram to full extension at least once with a minimum weight of 50 lbs applied.
Do not pressurize hydraulic system once fully extended
Do not allow jack to miss-stage when raising the rams to full extension
- Extend rams and visually inspect for corrosion, foreign matter, excessive wear and leaks around ram seals. Remove any foreign matter
- Apply DoAll, RPM, LPS or equivalent water repellant that is Buna N compatible to the rams
- Open release valve and verify that rams fully retract
- Lubricate casters (if applicable)

Annual (12-Month) Maintenance:

- Check hydraulic fluid for contamination (dirt/water) drain and flush if required
- Perform 90-day maintenance checklist
- Capacity test (105% - 110% of jack's rated capacity)

NOTE: The jack may be returned to Tronair for load testing, or sent to a local hydraulic repair shop. Please contact Tronair to obtain a "Return Material Authorization Number" (RMA #) before sending any product to Tronair.

the Tronair group of companies:

www.tronair.com | www.columbusjack.com | www.daeind.com | www.datcomedia.com | www.eagletugs.com | www.malabar.com