

**Model: 03-5842C4000  
Tailstand**



10/2010 – Rev. 01

REVISION  
01

DATE  
10/2010

TEXT AFFECTED  
Original Release

**TABLE OF CONTENTS**

**PAGE**

<b>1.0</b>	<b>PRODUCT INFORMATION</b> .....	<b>1</b>
<b>2.0</b>	<b>SAFETY INFORMATION</b> .....	<b>1</b>
2.1	ALARM and WARNING SYSTEMS.....	1
2.2	WARNING and DANGER SIGNS.....	1
2.3	COMPONENT SAFETY FEATURES.....	1
2.4	FUNCTIONAL SAFETY FEATURES.....	1
2.5	FEATURES FOR OPERATOR SAFETY.....	1
2.6	ENVIRONMENTAL SAFETY FEATURES.....	1
2.7	PROTECTION SYSTEMS.....	1
2.8	CLOSED CIRCUITS.....	1
2.9	INTERLOCKING.....	1
2.10	NECESSARY PERSONAL PROTECTIVE EQUIPMENT.....	1
2.11	SAFETY GUIDELINES.....	1
2.12	CONDITIONS FOR SAFE USE.....	1
2.13	OPERATOR QUALIFICATIONS.....	2
2.14	ADDITIONAL SAFETY MEASURES.....	2
<b>3.0</b>	<b>PACKAGING AND STORAGE</b> .....	<b>2</b>
3.1	PACKAGING REQUIREMENTS.....	2
3.2	HANDLING.....	2
3.3	STRAPPING.....	2
3.4	PACKAGING PROTECTION.....	2
3.5	LABELING OF PACKAGING.....	2
3.6	STORAGE COMPATIBILITY.....	2
3.7	STORAGE ENVIRONMENT.....	2
3.8	STORAGE SPACE AND HANDLING FACILITIES.....	2
<b>4.0</b>	<b>TRANSPORTATION</b> .....	<b>2</b>
<b>5.0</b>	<b>ASSEMBLY</b> .....	<b>2</b>
5.1	GENERAL INSTRUCTIONS.....	2
5.2	PRE-USE CHECKS.....	2
5.3	PERSONNEL REQUIREMENTS.....	2
5.4	ASSEMBLY STEPS.....	2
5.5	INSPECTION PROCEDURES.....	2
<b>6.0</b>	<b>INSTALLATION</b> .....	<b>3</b>
<b>7.0</b>	<b>OPERATION</b> .....	<b>3</b>
7.1	OPERATING PARAMETERS.....	3
7.2	NUMERICAL VALUES.....	3
7.3	OPERATOR CONTROLS.....	3
7.4	OPERATING INSTRUCTIONS.....	3
<b>8.0</b>	<b>TRAINING</b> .....	<b>4</b>
<b>9.0</b>	<b>MAINTENANCE</b> .....	<b>4</b>
9.1	MAINTENANCE SCHEDULE.....	4
9.2	TAILSTAND FUNCTION LOAD TEST.....	4
<b>10.0</b>	<b>TROUBLE SHOOTING</b> .....	<b>5</b>
<b>11.0</b>	<b>PROVISION OF SPARES</b> .....	<b>5</b>
11.1	SPARE PARTS.....	5
11.2	PARTS LIST.....	5
<b>12.0</b>	<b>IN-SERVICE SUPPORT</b> .....	<b>5</b>
<b>13.0</b>	<b>GUARANTEES/LIMITATION OF LIABILITY</b> .....	<b>5</b>
<b>14.0</b>	<b>APPENDICES</b> .....	<b>5</b>

This product can not be modified without the written approval of Tronair, Inc. Any modifications done without written approval voids all warranties and releases Tronair, Inc., its suppliers, distributors, employees, or financial institutions from any liability from consequences that may occur. Only Tronair OEM replacement parts shall be used.

## 1.0 PRODUCT INFORMATION

NAME OF EQUIPMENT: Tailstand, CE compliant  
MODEL NUMBER: 03-5842C4000 See Nameplate for Serial Number.  
MANUFACTURED BY: **TRONAIR**, Inc. 1 Air Cargo Pkwy., Swanton, OH 43558USA  
USAGE: The device is intended to stabilize an aircraft by its fuselage while aircraft is parked. Lightweight construction enables tailstand to be stowed on aircraft.  
LIST OF DRAWINGS: Reference Parts List and Illustrations.

## 2.0 SAFETY INFORMATION

### 2.1 ALARM and WARNING SYSTEMS

None

### 2.2 WARNING and DANGER SIGNS

See labels on unit.

### 2.3 COMPONENT SAFETY FEATURES

**Extension Lock Pin** provides a visual check that the pin is fully inserted to meet the rated load capacity of the tailstand.

### 2.4 FUNCTIONAL SAFETY FEATURES

None

### 2.5 FEATURES FOR OPERATOR SAFETY

Cautions and Instruction Labels located on tailstand.

### 2.6 ENVIRONMENTAL SAFETY FEATURES

Tailstand is non-polluting.

### 2.7 PROTECTION SYSTEMS

None

### 2.8 CLOSED CIRCUITS

None

### 2.9 INTERLOCKING

None

### 2.10 NECESSARY PERSONAL PROTECTIVE EQUIPMENT



**CAUTION!**  
Always wear safety glasses.

### 2.11 SAFETY GUIDELINES



- CAUTION!**
1. Tailstand operates by compressed spring force. Care must be taken during installation to prevent damage to aircraft.
  2. **DO NOT** place hands on threads while collapsing base during installation to aircraft. Pinch point exists between threads and base.
  3. **Never** put hands between aircraft and tailstand cradle.
  4. **ALWAYS** be sure tailstand extension lock pin is fully inserted and seated through tubing.

### 2.12 CONDITIONS FOR SAFE USE

- Use on a hard level surface.
- Tailstand to be used in all weather conditions.

**2.0 SAFETY INFORMATION** *(continued)***2.13 OPERATOR QUALIFICATIONS**

This tailstand is intended to be used by a skilled and trained aircraft personnel. The operator must be familiar with the operation of the tailstand.

**Installation/Maintenance/Dismantling Qualifications:** This tailstand is to be installed, maintained, and dismantled by qualified technicians familiar with aircraft maintenance systems.

**2.14 ADDITIONAL SAFETY MEASURES**

This tailstand must be used in accordance with this Technical manual, and in accordance with the aircraft manufacturer's jacking and stabilizing procedures.

**3.0 PACKAGING AND STORAGE****3.1 PACKAGING REQUIREMENTS**

Tailstand is to be packaged as required to prevent damage to equipment during shipment.

**3.2 HANDLING**

No special handling.

**3.3 STRAPPING**

Tailstand can be strapped down by suitable means to prevent unwanted movement during shipment.

**3.4 PACKAGING PROTECTION**

No special packaging material for cushioning or suspension is required.

**3.5 LABELING OF PACKAGING**

Packaging should be labeled DO NOT DROP.

**3.6 STORAGE COMPATIBILITY**

No special considerations.

**3.7 STORAGE ENVIRONMENT**

- Always store tailstand with extension lock in place.
- Suitable for outdoor storage by using a full coverage waterproof tarp or canvas.

**3.8 STORAGE SPACE AND HANDLING FACILITIES**

- Maximum Height Obtainable: 37 5/8 in (95.6 cm)
- Weight: 11 lbs (5 kg)

**4.0 TRANSPORTATION**

Transport by any means. Approximate weight 11 lbs (5 kg).

**5.0 ASSEMBLY****5.1 GENERAL INSTRUCTIONS**

1. This product should be assembled and/or repaired using good workmanship practices and proper tools.
2. All replacement parts must be the same as or better than the original parts supplied.
3. No modifications are allowed as they may adversely affect the tailstand's safety performance.

**5.2 PRE-USE CHECKS**

1. Refer to the Illustrated Parts List identify and ensure that all parts are present.
2. Generally check over unit to assure the unit is properly assembled and in working order.

**5.3 PERSONNEL REQUIREMENTS**

This tailstand is to be assembled by qualified technicians familiar with aircraft maintenance systems.

**5.4 ASSEMBLY STEPS**

Product is shipped fully assembled.

**5.5 INSPECTION PROCEDURES**

Visually inspect all welds, cradle, lock pin, and lock pin holes in the base and extension for defects. If defects are found, remove tailstand from active service until repairs are made.

## 6.0 INSTALLATION

None

## 7.0 OPERATION

### 7.1 OPERATING PARAMETERS

1. The user shall work in accordance with the Operator Manual.
2. The employer of the operator shall provide all necessary training.
3. Operate in all weather conditions.

### 7.2 NUMERICAL VALUES

- Target Working Height:: 31 in (78.7 cm)
- Maximum Height: 34 in (86 cm)
- Minimum Height: 29 in (73.7 cm)
- Weight: 11 lbs (5 kg)

### 7.3 OPERATOR CONTROLS

Adjusting lock nuts

### 7.4 OPERATING INSTRUCTIONS

The user should be familiar with the following statements prior to using the tailstand:



#### CAUTION!

1. Tailstand operates by compressed spring force. Care must be taken during installation to prevent damage to aircraft.
2. **DO NOT** place hands on threads while collapsing base for installation to aircraft. Pinch point exists between threads and base.
3. **Never** put hands between aircraft and tailstand cradle.
4. **ALWAYS** be sure tailstand extension lock pin is fully inserted and seated through tubing.

#### 7.4.1 Rules For Operating

- A. The user shall work in accordance with the Operator and/or Technical Manuals.
- B. The employer of the operator shall provide all necessary training.
- C. Operate in all weather conditions.

#### 7.4.2 Tailstand Instructions

Refer to Figures 1, 2 and 3

#### To Stabilize Aircraft:

1. Back off jam nut and lock nut
2. Locate tailstand cradle on skid from back side of aircraft and compress spring to locate base of tailstand on the ground Note: Spring load will be approximately 10 lbs
3. Secure aircraft to skid and cradle with ball lock pin
4. Use adjusting nut to apply upward force the skid. This keeps the tailstand base firmly contacted on the ground.
5. Lock the adjusting nut with jam nut to secure tailstand

#### To Remove Tailstand From Aircraft:

1. Loosen jam nut and unscrew both the jam nut and the adjusting nut
2. Remove ball lock pin jamming cradle and skid
3. Carefully collapse tailstand and remove base and then cradle

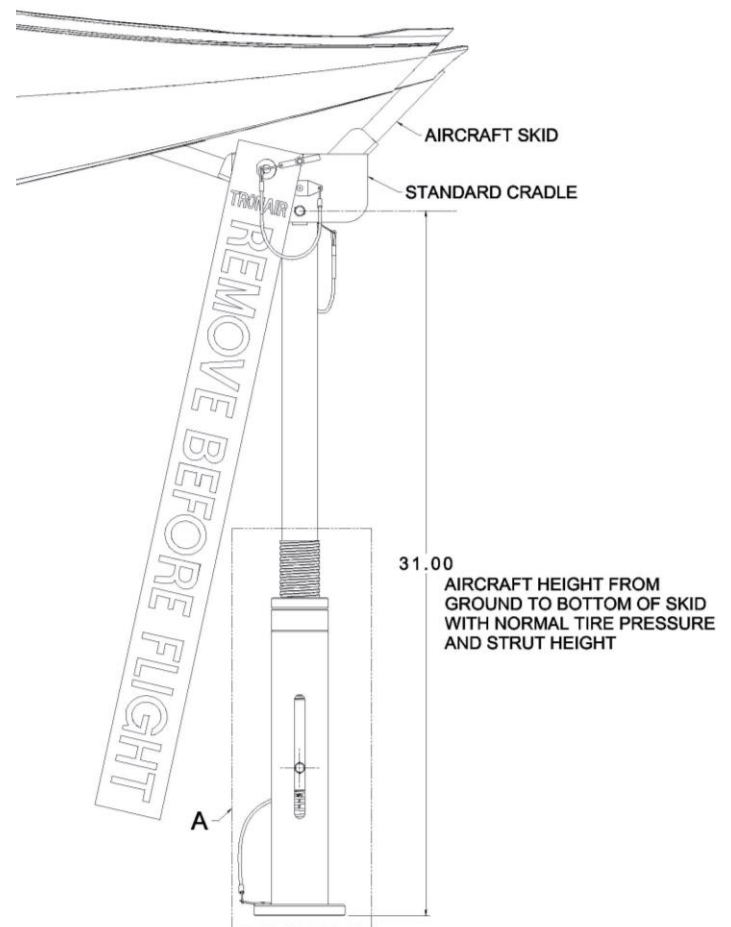
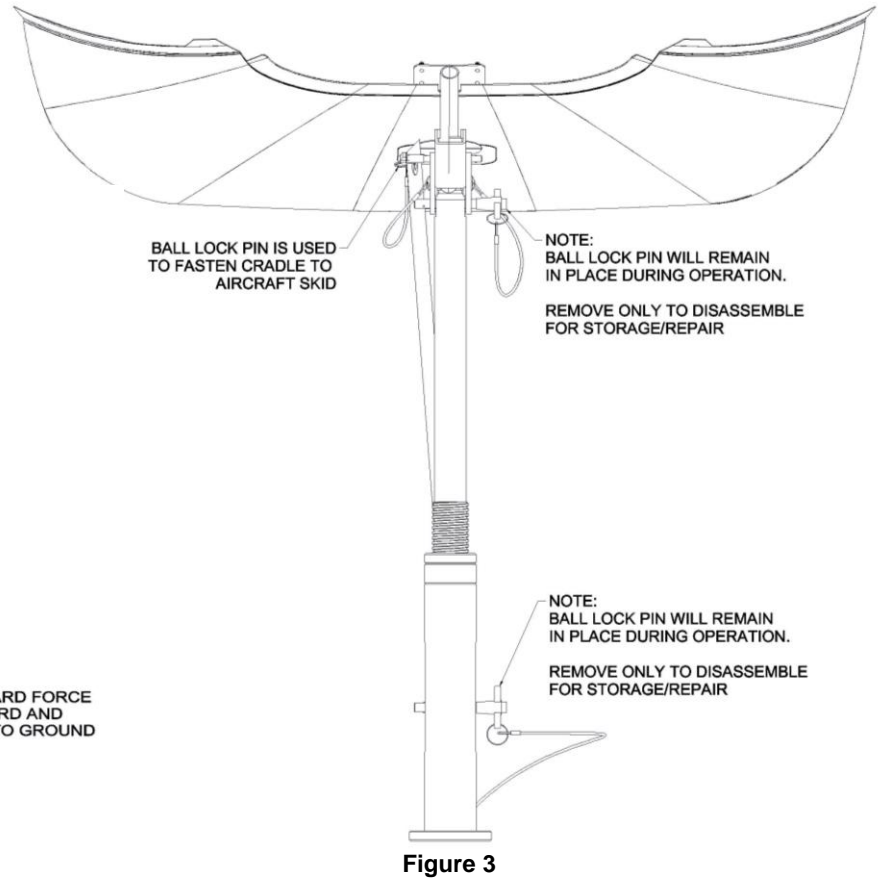
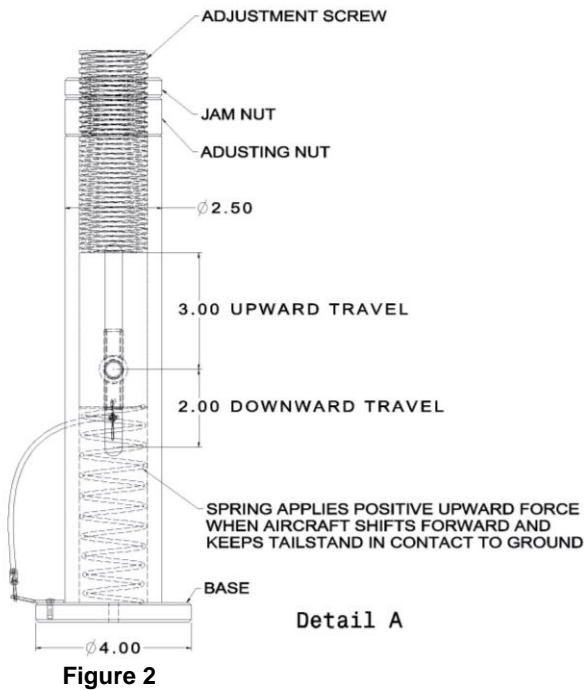

Figure 1

## 7.4 OPERATING INSTRUCTIONS (continued)



## 8.0 TRAINING

Training of operating personnel is the responsibility of the employer. This tailstand must be used in accordance with aircraft manufacturer's instructions.

## 9.0 MAINTENANCE

### GENERAL

- All maintenance and/or repair work should be done using good workmanship practices and proper tools.
- Tailstand shall be maintained and repaired in accordance with the manufacturer's instructions. Such maintenance and repair shall be carried out by qualified persons.
- No modifications shall be carried out as they may adversely affect the compliance of the tailstand with draft standard 2006/42/EC.

### 9.1 MAINTENANCE SCHEDULE

Cleaning Annually or as Needed

**NOTE: Wipe with soft cloth only, do not pressure wash or spray water directly at cradle.**

### 9.2 TAILSTAND FUNCTION LOAD TEST

**NOTE: If function load testing is required:**

- Take all necessary precautions to prevent injury.
- Do not exceed a test load equal to 110% of the tailstand rated capacity.

## 10.0 TROUBLE SHOOTING

None

## 11.0 PROVISION OF SPARES

### 11.1 SPARE PARTS

Spare parts may be obtained from the Manufacturer:

**TRONAIR**, Inc.

1 Air Cargo Pkwy East

Swanton, Ohio 43558 USA

Telephone: (419) 866-6301 or 800-426-6301

Fax: (419) 867-0634

E-mail: sales@tronair.com

Website: www.tronair.com

### 11.2 PARTS LIST

Reference following page for ordering information of Replacement Parts and Kits.

When ordering Replacement Parts/Kits, please specify Model & Serial Number of your product.

## 12.0 IN-SERVICE SUPPORT

Contact Tronair for technical services and information.

## 13.0 GUARANTEES/LIMITATION OF LIABILITY

Tronair products are warranted to be free of manufacturing or material defects for a period of one year after shipment to the original customer. This is solely limited to the repair or replacement of defective components. This warranty does not cover the following items:

- a) Parts required for normal maintenance
- b) Parts covered by a component manufacturers warranty
- c) Replacement parts have a 90-day warranty from date of shipment

If you have a problem that may require service, contact Tronair immediately. Do not attempt to repair or disassemble a product without first contacting Tronair, any action may affect warranty coverage. When you contact Tronair be prepared to provide the following information:

- a) Product Model Number
- b) Product Serial Number
- c) Description of the problem

If warranty coverage is approved, either replacement parts will be sent or the product will have to be returned to Tronair for repairs. If the product is to be returned, a Return Material Authorization (RMA) number will be issued for reference purposes on any shipping documents. Failure to obtain a RMA in advance of returning an item will result in a service fee. A decision on the extent of warranty coverage on returned products is reserved pending inspection at Tronair. Any shipments to Tronair must be shipped freight prepaid. Freight costs on shipments to customers will be paid by Tronair on any warranty claims only. Any unauthorized modification of the Tronair products or use of the Tronair products in violation of cautions and warnings in any manual (including updates) or safety bulletins published or delivered by Tronair will immediately void any warranty, express or implied.

The obligations of Tronair expressly stated herein are in lieu of all other warranties or conditions expressed or implied. **Any unauthorized modification of the Tronair products or use of the Tronair products in violations of cautions and warnings in any manual (including updates) or safety bulletins published or delivered by Tronair will immediately void any warranty, express or implied and Tronair disclaims any and all liability for injury (WITHOUT LIMITATION and including DEATH), loss or damage arising from or relating to such misuse.**

## 14.0 APPENDICES

APPENDIX I Declaration of Conformity



## Parts List

When ordering Replacement Parts/Kits, please specify Model & Serial Number of your product.

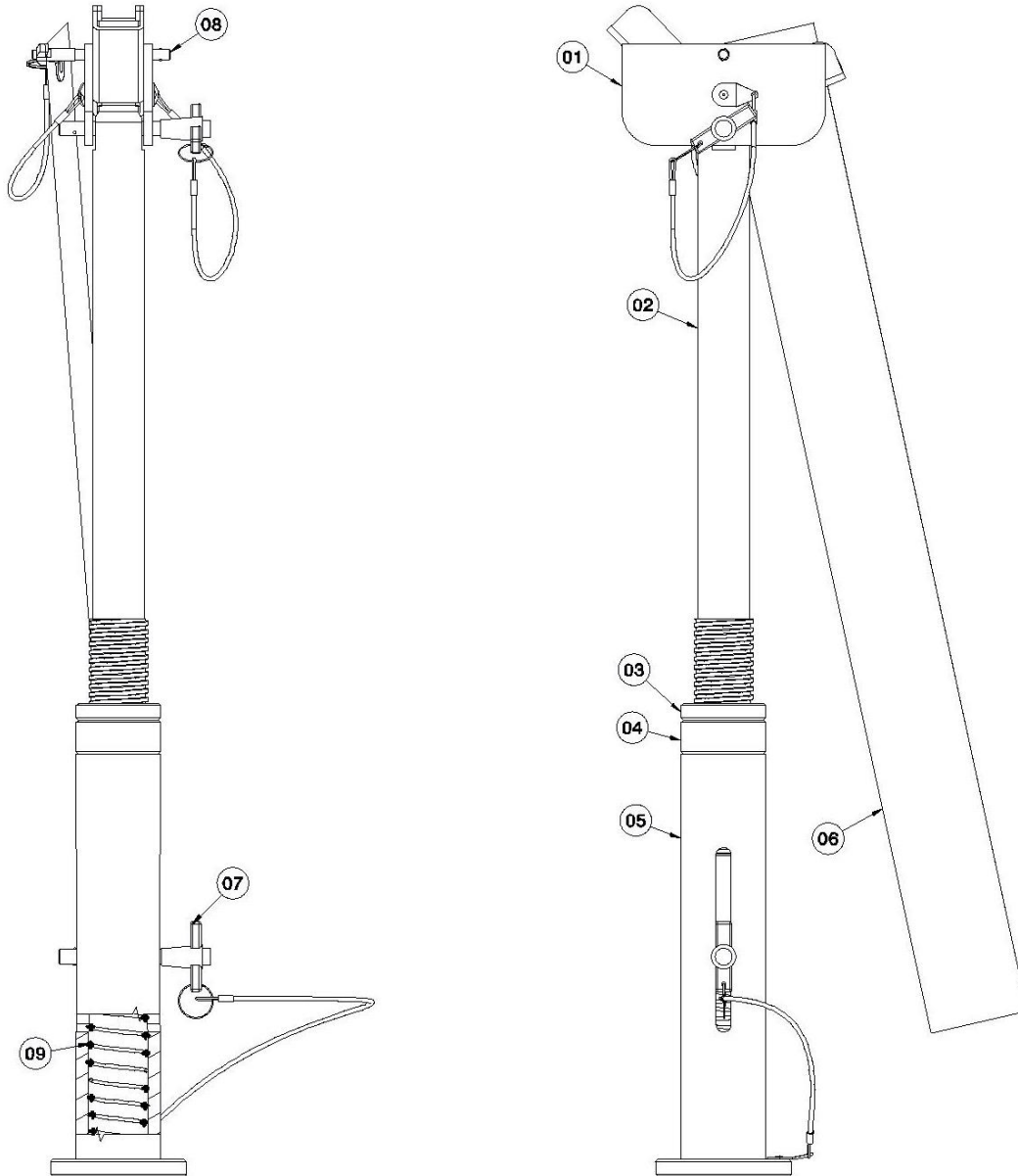

Item	Part Number	Description	Qty
1	Z-7397	Weldment, Cradle	1
2	R-2536	Screw, Adjusting	1
3	TR-2163	Nut, Jam	1
4	TR-2164	Nut, Adjusting	1
5	Z-7398	Weldment, Base	1
6	B-160-02	Banner, Remove Before Flight	1
7	G-1310-0725	Pin, 7/16 x 2.5 Ball Lok-T	2
8	G-1310-0525	Bolt, 5/16 x 2.5 Ball Lok-T	1
9	H-3334	Spring, Compression	1





## **APPENDIX I**

### **Declaration of Conformity**





## DECLARATION of CONFORMITY

The design, development and manufacture is in accordance with European Community guidelines

TAILSTAND  
03-5842C4000

Relevant provisions complied with by the machinery:  
2006/42/EC

Relevant standards complied with by the machinery:  
EN ISO 12100-1

Identification of person empowered to sign on behalf of the Manufacturer:

A handwritten signature in cursive script that reads "Patrick Finch". The signature is written in black ink and is positioned above a solid horizontal line.

Quality Assurance Representative