

Model: 03A5860C0000
Global 7000/8000
Tailstand with Alarm



06/2022 – Rev. 01

For Spare Parts, Operations & Service Manuals or Service Needs
Scan the QR code or visit Tronair.com/aftermarket



REVISION
01

DATE
06/2022

TEXT AFFECTED
Original Release

TABLE OF CONTENTS

PAGE

1.0	PRODUCT INFORMATION	1
1.1	DESCRIPTION	1
1.2	MODEL & SERIAL NUMBER	1
1.3	MANUFACTURER	1
1.4	FUNCTION	1
2.0	SAFETY INFORMATION	1
2.1	USAGE AND SAFETY INFORMATION	1
2.2	ALARM AND WARNING SYSTEMS	1
2.3	COMPONENT SAFETY FEATURES	1
2.4	ENVIRONMENTAL SAFETY FEATURES	1
2.5	CLOSED CIRCUITS	1
2.6	NECESSARY PERSONAL PROTECTIVE EQUIPMENT	1
2.7	SAFETY GUIDELINES	2
2.8	CONDITIONS FOR SAFE USE	2
2.9	OPERATOR QUALIFICATIONS	2
2.10	ADDITIONAL SAFETY MEASURES	2
3.0	ASSEMBLY	3
3.1	GENERAL INSTRUCTIONS	3
3.2	PRE-USE CHECKS	3
3.3	PERSONNEL REQUIREMENTS	3
3.4	ASSEMBLY STEPS	3
3.5	INSPECTION AND TEST PROCEDURES	3
4.0	TRAINING	3
4.1	TRAINING REQUIREMENTS	3
4.2	TRAINING PROGRAM	3
4.3	OPERATOR TRAINING	3
5.0	OPERATION	4
5.1	OPERATING PARAMETERS	4
5.2	NUMERICAL VALUES	4
5.3	OPERATING INSTRUCTIONS	4
5.3.1	Rules For Operating	4
5.3.2	Operation	4
5.3.3	Alarm Test	4
5.3.4	Alarm Load Test	4
5.3.5	Tailstand Instructions	5
6.0	PACKAGING AND STORAGE	6
6.1	PACKAGING REQUIREMENTS	6
6.2	STRAPPING	6
6.3	PACKAGING PROTECTION	6
6.4	LABELING OF PACKAGING	6
6.5	STORAGE ENVIRONMENT	6
6.6	STORAGE SPACE AND HANDLING FACILITIES	6
7.0	TROUBLE SHOOTING	6
7.1	ALARM WILL NOT SOUND	6
7.2	ALARM PRODUCES AN ERRATIC OR LOW SOUND	6
8.0	MAINTENANCE	6
8.1	GENERAL	6
8.2	MAINTENANCE SCHEDULE	6
8.3	CLEANING ALARM	6
9.0	PROVISION OF SPARES	7
9.1	SOURCE OF SPARE PARTS	7
9.2	RECOMMENDED SPARE PARTS LISTS	7
10.0	IN-SERVICE SUPPORT	7
11.0	GUARANTEES/LIMITATION OF LIABILITY	7
12.0	APPENDICES	7

This product can not be modified without the written approval of Tronair, Inc. Any modifications done without written approval voids all warranties and releases Tronair, Inc., its suppliers, distributors, employees, or financial institutions from any liability from consequences that may occur. Only Tronair OEM replacement parts shall be used.

1.0 PRODUCT INFORMATION

1.1 DESCRIPTION

Global 7000/8000 tailstand with alarm.

1.2 MODEL & SERIAL NUMBER

Reference nameplate on unit

1.3 MANUFACTURER

TRONAIR, Inc.
1 Air Cargo Pkwy East
Swanton, Ohio 43558 USA

Telephone: (419) 866-6301 or 800-426-6301
Fax: (419) 867-0634
E-mail: sales@tronair.com
Website: www.tronair.com

1.4 FUNCTION

The device is intended to stabilize an aircraft by its fuselage during maintenance, whose maximum load does not exceed the rated capacity of the tailstand.

2.0 SAFETY INFORMATION

2.1 USAGE AND SAFETY INFORMATION

To ensure safe operations please read the following statements and understand their meaning. Also refer to your equipment manufacturer's manual for other important safety information. This manual contains safety precautions which are explained below. Please read carefully.



WARNING! — Warning is used to indicate the presence of a hazard that **can cause severe personal injury, death, or substantial property damage** if the warning notice is ignored.

CAUTION! — Caution is used to indicate the presence of a hazard that **will or can cause minor personal injury or property damage** if the caution notice is ignored.

2.2 ALARM AND WARNING SYSTEMS

The tailstand has an alarm system that alerts the operator that a force of 100 to 150 pounds (45.36 to 68.04 kg) is being applied to the top of the cradle. The unit attached to the tailstand sounds a loud 85 db pulsating alarm until the force is reduced.

2.3 COMPONENT SAFETY FEATURES

Extension Pin provides a visual check that the pin is fully inserted

2.4 ENVIRONMENTAL SAFETY FEATURES

Tailstand is non-polluting.

2.5 CLOSED CIRCUITS

Reference **Figure 1**

2.6 NECESSARY PERSONAL PROTECTIVE EQUIPMENT



CAUTION!

Always wear safety glasses.

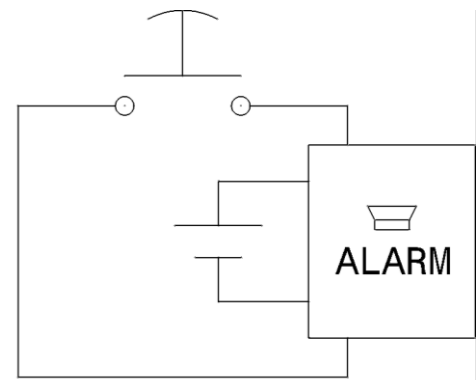

Figure 1 – Closed Circuits

2.7 SAFETY GUIDELINES

**CAUTION!**

1. **DO NOT** place hands on top of tailstand near base tube receiver while lowering tailstand extension. Pinch point exists between top of tube and bracket on extension.
2. **DO NOT** place feet under tailstand near base tube receiver while lowering tailstand extension. Pinch point exists between ground and extension tube.
3. **ALWAYS** install tailstand **AFTER** aircraft has been jacked to working position.
4. **Never** put hands between aircraft and tailstand cradle.
5. **ALWAYS** be sure tailstand extension pin is fully locked and inserted through the tube.
6. **NEVER** load tailstand by lowering jacks. **ALWAYS** lower and remove tailstand **BEFORE** lowering aircraft.
7. **DO NOT** place hands near the die springs on the load alarm while the stabilization stand is in use. Pinch point exists on the die springs and between the top plate and the base of the load alarm.
8. **DO NOT** allow prolonged exposure to the sounding alarm. The alarm sound may cause permanent hearing loss.
9. **DO NOT** place objects in the path of the alarm's horn opening that may limit the audible range and reduce the effectiveness of the alarm.
10. **DO NOT** turn setscrew located under the plunger switch. The distance between the setscrew and plunger is pre-set by the factory.

2.8 CONDITIONS FOR SAFE USE

- Use in a clean dry environment, on a hard level surface.
- Operate between +4° C and 38° C/+40° F and 100° F.

2.9 OPERATOR QUALIFICATIONS

This tailstand is intended to be used by a skilled and trained aircraft technician. The operator must be familiar with the jacking procedures for the aircraft to be raised, and the operation of the tailstand.

Installation/Maintenance/Dismantling Qualifications: This tailstand is to be installed, maintained, and dismantled by qualified technicians familiar with aircraft maintenance systems.

2.10 ADDITIONAL SAFETY MEASURES

This tailstand must be used in accordance with this Operation and Service manual, and in accordance with the aircraft manufacturer's jacking and stabilizing procedures.

3.0 ASSEMBLY

3.1 GENERAL INSTRUCTIONS

1. This product should be assembled and/or repaired using good workmanship practices and proper tools. Bolts and elastic stopnuts should be tightened to a torque not to exceed industry standards for Grade 5 bolts.
2. All replacement parts must be the same as or better than the original parts supplied.
3. No modifications are allowed as they may adversely affect the tailstand's safety performance.

3.2 PRE-USE CHECKS

1. Refer to the Illustrated Parts List to identify and ensure that all parts are present.
2. Generally check over unit and ensure the tightness of all nuts and bolts.

3.3 PERSONNEL REQUIREMENTS

This jack is to be assembled by qualified technicians familiar with aircraft maintenance systems.

3.4 ASSEMBLY STEPS

Install the 12 volt battery in the alarm bracket.

3.5 INSPECTION AND TEST PROCEDURES

1. Depress the plunger switch to check electronic circuit. The alarm will sound when the switch is engaged. (see Figure 2)
2. Test alarm by slowly applying an evenly distributed force of 100 to 150 lbs (45.36 to 68.04 kg) across the top of the cradle. The top plate of the load alarm kit will lower and engage the plunger switch, A loud pulsating alarm will then sound. If alarm does not sound, refer to the Troubleshooting section. (see Figure 2)

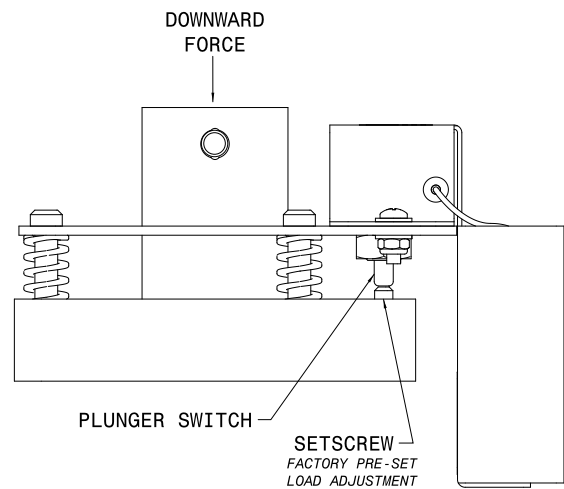

Figure 2

4.0 TRAINING

4.1 TRAINING REQUIREMENTS

Training of operating personnel is the responsibility of the employer. This tailstand must be used in accordance with aircraft manufacturer's instructions.

4.2 TRAINING PROGRAM

The employer provided operator training program should cover safety procedures concerning use of the unit in and around the intended aircraft at the intended aircraft servicing location.

4.3 OPERATOR TRAINING

The operator training should provide the required training for safe operation of the unit.

NOTE: Maintenance and Trouble Shooting are to be performed by a skilled and trained technician.

5.0 OPERATION**5.1 OPERATING PARAMETERS**

1. The user shall work in accordance with the Operator and Maintenance Manual.
2. The employer of the operator shall provide all necessary training.
3. Operate between +4° C and 38° C/+40° F and 100° F.

5.2 NUMERICAL VALUES

Minimum Closed Height 80 in (203 cm)
Maximum Height Obtainable 123 in (312 cm)
Weight 164 lbs (74 kg)
Alarm (Battery Powered) 12 vdc
Alarm Horn 85 db

5.3 OPERATING INSTRUCTIONS

The user should be familiar with the following statements prior to using the tailstand:

**CAUTION!**

1. **DO NOT** place hands on top of tailstand near base tube receiver while lowering tailstand extension. Pinch point exists between top of tube and bracket on extension.
2. **DO NOT** place feet under tailstand near base tube receiver while lowering tailstand extension. Pinch point exists between ground and extension tube.
3. **ALWAYS** install tailstand **AFTER** aircraft has been jacked to working position.
4. **Never** put hands between aircraft and tailstand cradle.
5. **ALWAYS** be sure tailstand extension pin is fully locked and inserted through the tube.
6. **NEVER** load tailstand by lowering jacks. **ALWAYS** lower and remove tailstand **BEFORE** lowering aircraft.
7. **DO NOT** place hands near the die springs on the load alarm while the stabilization stand is in use. Pinch point exists on the die springs and between the top plate and the base of the load alarm.
8. **DO NOT** allow prolonged exposure to the sounding alarm. The alarm sound may cause permanent hearing loss.
9. **DO NOT** place objects in the path of the alarm's horn opening that may limit the audible range and reduce the effectiveness of the alarm.
10. **DO NOT** turn setscrew located under the plunger switch. The distance between the setscrew and plunger is pre-set by the factory.

5.3.1 Rules For Operating

- a. The user shall work in accordance with the Operator and Service Manual.
- b. The employer of the operator shall provide all necessary training.
- c. Operate between +4° C and 38° C/+40° F and 100° F.

5.3.2 Operation

When a force of 100 to 150 pounds (45.36 to 68.04 kg) is applied to the top of the cradle, the cradle head will lower and depress the plunger switch. This will activate the alarm, which sounds a loud 85 db pulsating alarm until the force is reduced.

5.3.3 Alarm Test

Depress plunger switch and hold for a minimum of two (2) seconds. This will sound the alarm if the electronic circuitry, horn and battery are operating correctly. Refer to Trouble Shooting section of this manual if test fails.

5.3.4 Alarm Load Test

Place a force between 100 to 150 lbs (45.36 to 68.04 kg) to the top of the cradle. This will activate the alarm. Refer to Trouble Shooting section of this manual if test fails.

5.3.5 Tailstand Instructions

To Raise Aircraft:

- Jack aircraft to desired height.
- Place tailstand on a hard, level surface.
- Position tailstand at aircraft manufacturer's recommended location.
- Raise tailstand extension padded cradle as close to aircraft as possible.
- Install tailstand extension pin.
- Extend extension screw to obtain addition light if required.
- Make necessary adjustments to reduce force on tailstand when the alarm sounds.



WARNING!

The locking pin **MUST** be placed fully through the inner and outer extension tube.

The locking pin washer and ball lock **MUST** be placed outside the outer extension tube.

- Do not place extra locking pins in any other hole on the inner extension tube.
- Under no conditions should the locking pin's ball lock be inside the inner and outer extension tube.
- Never use a locking pin that has been damaged.
- Never use an inner and outer extension tube that has been damaged or deformed.
- Failure to comply could result in premature failure below certified weight and could cause serious injury including death.

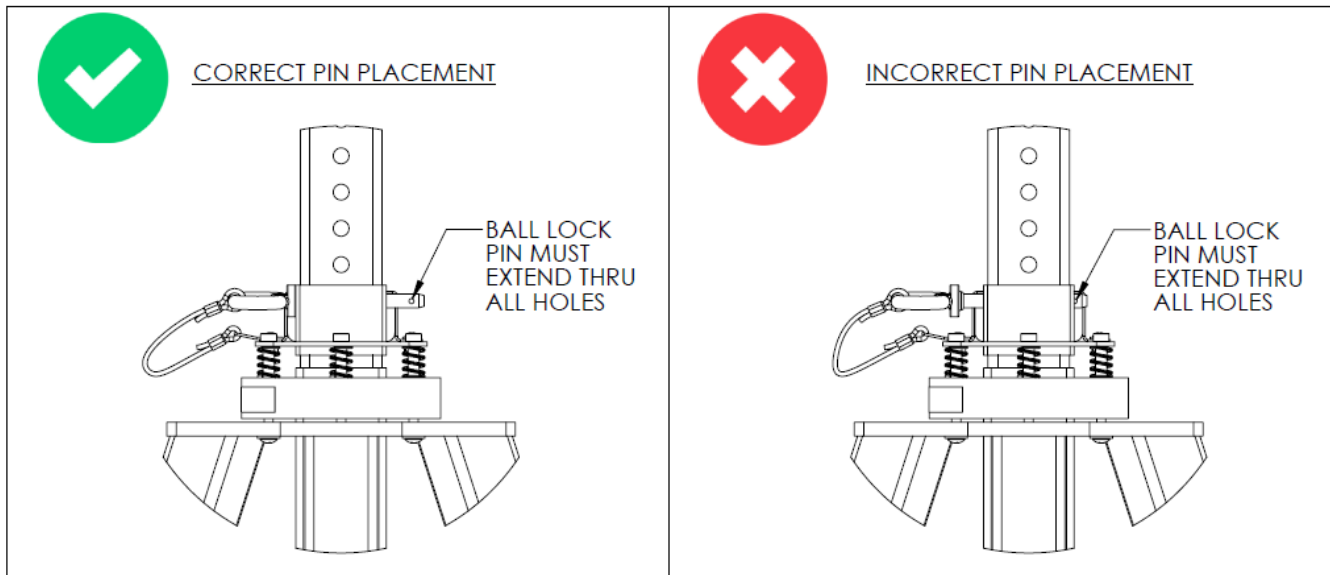

To Lower Aircraft:

- Clear all personnel from inside and under aircraft.
- Make necessary adjustments to reduce force on tailstand when the alarm sounds.
- Lower extension screw.
- Remove tailstand extension pin and lower extension.
- Relocate tailstand away from aircraft and secure.
- Lower aircraft to the ground.



CAUTION!

1. **DO NOT** place hands on top of tailstand near base tube receiver while lowering tailstand extension. Pinch point exists between top of tube and bracket on extension.
2. **DO NOT** place feet under tailstand near base tube receiver while lowering tailstand extension. Pinch point exists between ground and extension tube.
3. **ALWAYS** wear safety glasses.

6.0 PACKAGING AND STORAGE

6.1 PACKAGING REQUIREMENTS

Tailstand is to be packaged as required to prevent damage to legs or cradle equipment during shipment.

6.2 STRAPPING

Tailstand can be strapped down by suitable means to prevent unwanted movement during shipment.

6.3 PACKAGING PROTECTION

No special packaging material for cushioning or suspension is required.

6.4 LABELING OF PACKAGING

Packaging should be labeled **DO NOT DROP**.

6.5 STORAGE ENVIRONMENT

- Store tailstand between +4° C and +38° C/+40° F and 100° F.
- Always store tailstand with extension all the way down.
- Tailstand must be stored in a clean and dry environment.

6.6 STORAGE SPACE AND HANDLING FACILITIES

Minimum Closed Height 80 in (203 cm)
Maximum Height Obtainable 123 in (312 cm)
Weight 164 lbs (74 kg)

7.0 TROUBLE SHOOTING

7.1 ALARM WILL NOT SOUND

Possible Cause	Solution
Load was on the cradle for a short period of time	Limit switch has to be engaged for a minimum of two (2) seconds
Defective alarm	Replace alarm
Battery power depleted	Replace battery
Defective Limit Switch	Replace limit switch
Broken wire connection	Check wire connection between limit switch and alarm
Cradle head did not lower far enough to contact limit switch	Test per Section 3.5

7.2 ALARM PRODUCES AN ERRATIC OR LOW SOUND

Possible Cause	Solution
Defective alarm	Replace alarm

8.0 MAINTENANCE

8.1 GENERAL

- All maintenance and/or repair work should be done using good workmanship practices and proper tools.
- Tailstand shall be maintained and repaired in accordance with the manufacturers instructions. Such maintenance and repair shall be carried out by qualified persons.
- No modifications shall be carried out.

8.2 MAINTENANCE SCHEDULE

Cleaning: Annually or as Needed

NOTE: Wipe with soft cloth only, do not pressure wash or spray water directly at cradle.

8.3 CLEANING ALARM

The openings around the alarm perimeter may be cleared of debris by using compressed air or a vacuum cleaner hose to blow/suction openings. The outside surface of the alarm unit may be wiped with a damp cloth.

9.0 PROVISION OF SPARES

9.1 SOURCE OF SPARE PARTS

Spare parts may be obtained from the manufacturer:

TRONAIR, Inc.
1 Air Cargo Pkwy East
Swanton, Ohio 43558 USA

Telephone: (419) 866-6301 or 800-426-6301
Fax: (419) 867-0634
E-mail: sales@tronair.com
Website: www.tronair.com

For Spare Parts, Operations & Service Manuals or Service Needs:
Scan the QR code or visit Tronair.com/aftermarket



9.2 RECOMMENDED SPARE PARTS LISTS

Reference the following page(s) for Replacement Parts and Kits available.

10.0 IN-SERVICE SUPPORT

Contact Tronair, Inc. for technical services and information. See Section 1.3 – Manufacturer.

11.0 GUARANTEES/LIMITATION OF LIABILITY

Tronair products are warranted to be free of manufacturing or material defects for a period of one year after shipment to the original customer. This is solely limited to the repair or replacement of defective components. This warranty does not cover the following items:

- a) Parts required for normal maintenance
- b) Parts covered by a component manufacturers warranty
- c) Replacement parts have a 90-day warranty from date of shipment

If you have a problem that may require service, contact Tronair immediately. Do not attempt to repair or disassemble a product without first contacting Tronair, any action may affect warranty coverage. When you contact Tronair be prepared to provide the following information:

- a) Product Model Number
- b) Product Serial Number
- c) Description of the problem

If warranty coverage is approved, either replacement parts will be sent or the product will have to be returned to Tronair for repairs. If the product is to be returned, a Return Material Authorization (RMA) number will be issued for reference purposes on any shipping documents. Failure to obtain a RMA in advance of returning an item will result in a service fee. A decision on the extent of warranty coverage on returned products is reserved pending inspection at Tronair. Any shipments to Tronair must be shipped freight prepaid. Freight costs on shipments to customers will be paid by Tronair on any warranty claims only. Any unauthorized modification of the Tronair products or use of the Tronair products in violation of cautions and warnings in any manual (including updates) or safety bulletins published or delivered by Tronair will immediately void any warranty, express or implied.

The obligations of Tronair expressly stated herein are in lieu of all other warranties or conditions expressed or implied. **Any unauthorized modification of the Tronair products or use of the Tronair products in violations of cautions and warnings in any manual (including updates) or safety bulletins published or delivered by Tronair will immediately void any warranty, express or implied and Tronair disclaims any and all liability for injury (WITHOUT LIMITATION and including DEATH), loss or damage arising from or relating to such misuse.**

12.0 APPENDICES

- APPENDIX I Declaration of Conformity
- APPENDIX II Rockwell Automation Bulletin 855P/855PC

Parts List

When ordering replacement parts/kits, please specify model, serial number and color of your unit.

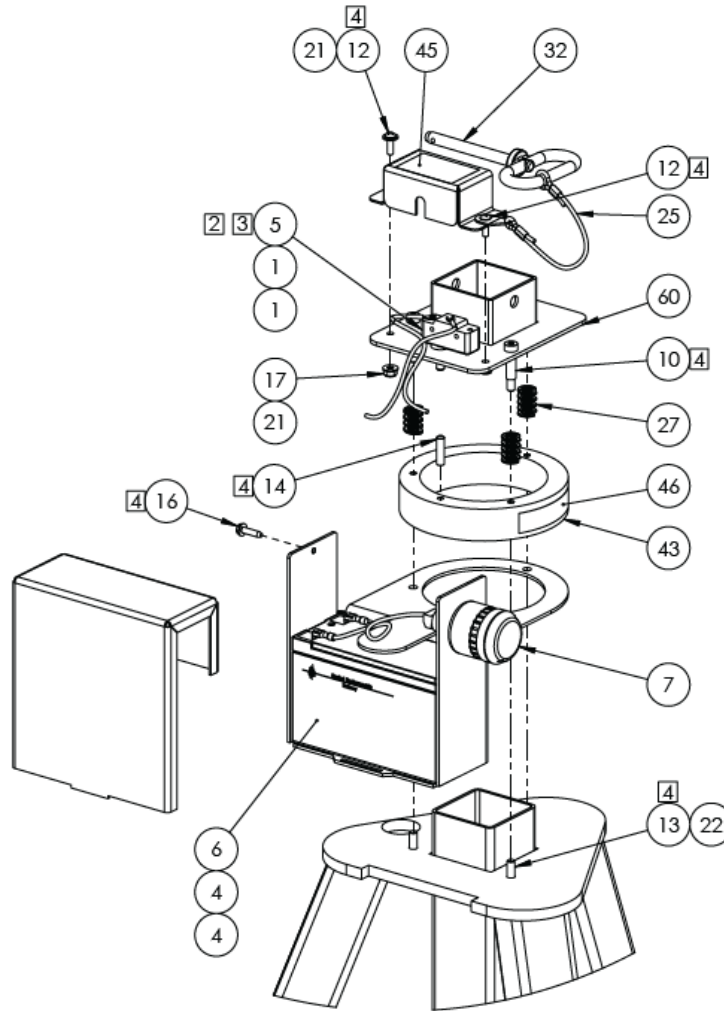

NOTE:

- 2 MOUNT ITEM 5 TO ITEM 60 USING THE TWO PROVIDED JAMNUTS. DISCARD REMAINING HARDWARE
- 3 WIRE ALARM AS FOLLOWS:
 WHITE WIRE – BATTERY NEGATIVE TO LIGHT (N)
 BLACK WIRE – BATTERY POSITIVE TO MICROSWITCH N.O.
 BLACK WIRE –MICROSWITCH COMMON TO LIGHT (La)
- 4 APPLY LOCTITE 271 TO ITEMS 10, 11, 12, 14, 13, 15, 16, 28

Parts List

When ordering replacement parts/kits, please specify model, serial number and color of your unit.

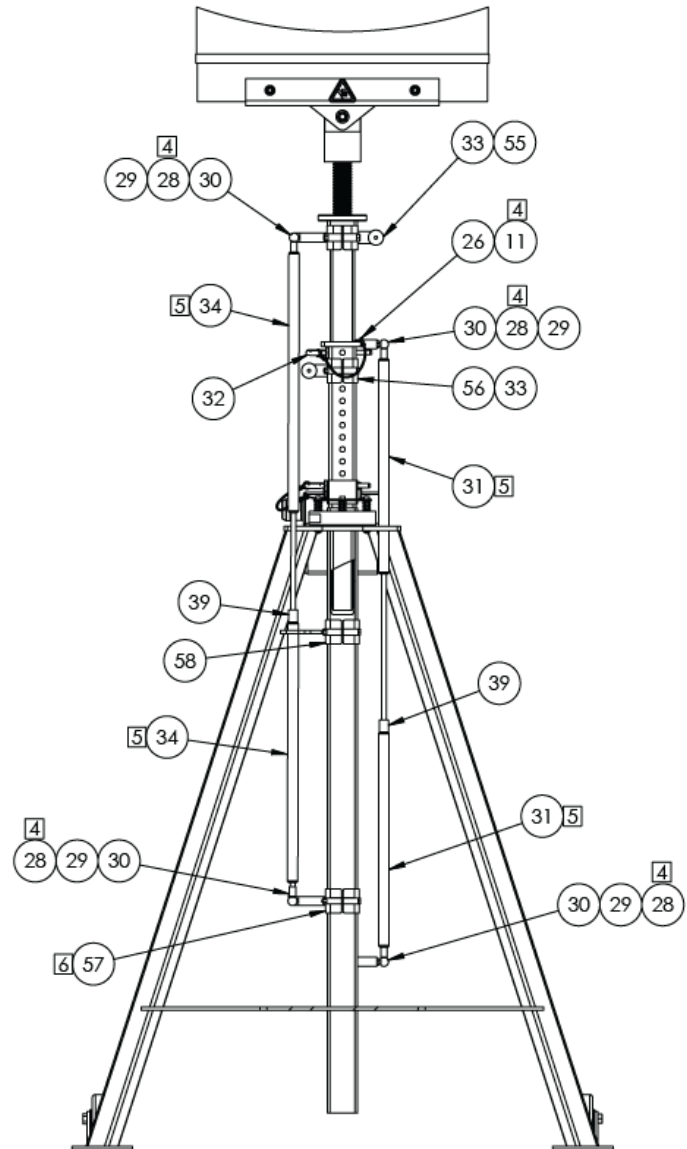
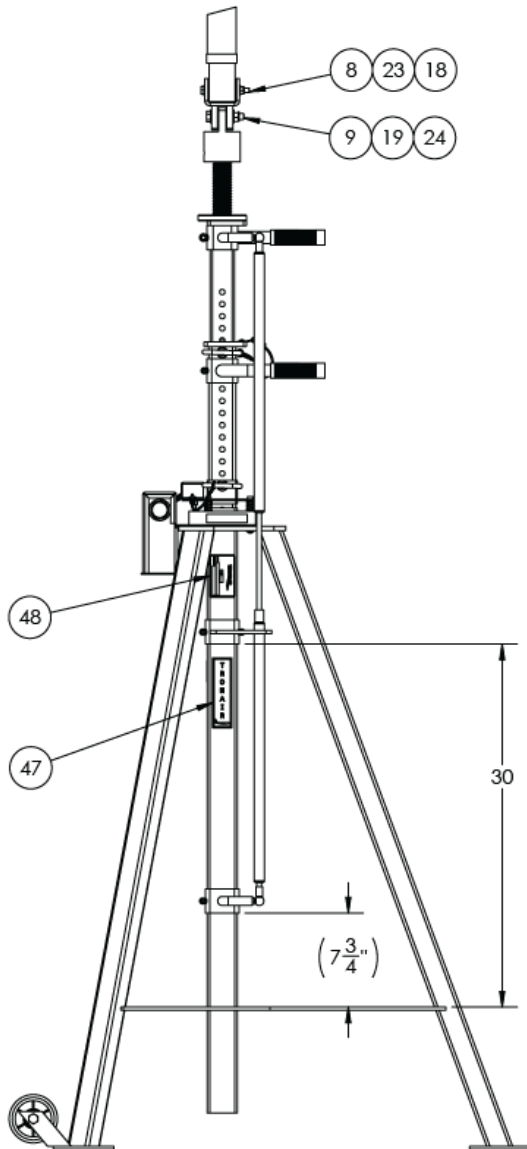

"FRONT" LEG HIDDEN FOR CLARITY

NOTE:

- 4 APPLY LOCTITE 271 TO ITEMS 10, 11, 12, 14, 13, 15, 16, 28
- 5 INSTALL ALL GAS SHOCKS WITH ROD EXTENDING DOWN FROM CYLINDER
- 6 TO SET LOCATION OF ITEM 57, INSTALL ALL OTHER COMPONENTS, SET TAILSTAND TO MAX TUBE EXTENSION AND PIN IN PLACE, THEN SECURE ITEM 57

Parts List

When ordering replacement parts/kits, please specify model, serial number and color of your unit.

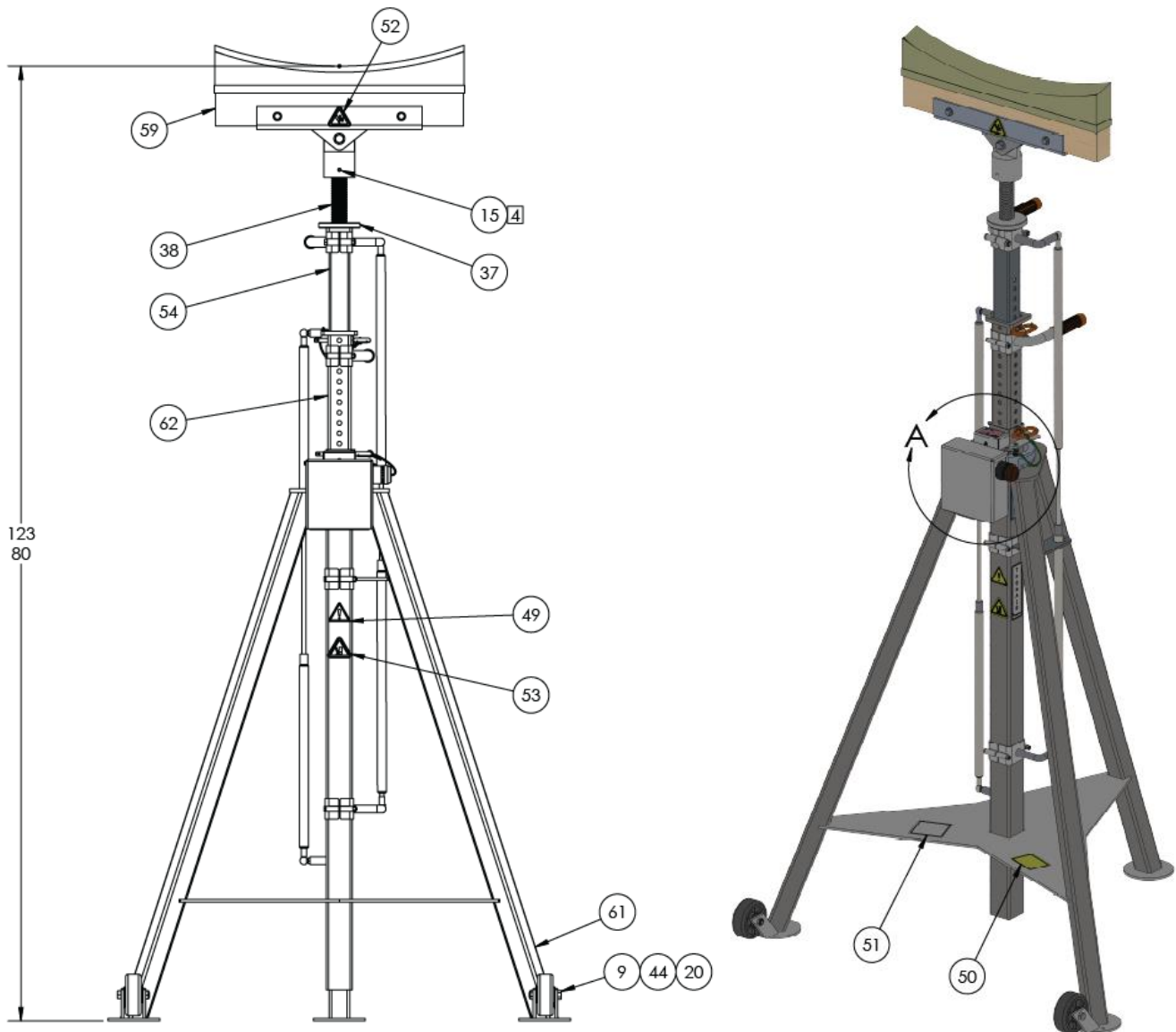

NOTE:

4 APPLY LOCTITE 271 TO ITEMS 10, 11, 12, 14, 13, 15, 16, 28

Parts List

When ordering replacement parts/kits, please specify model, serial number and color of your unit.

Item	Part Number	Description	Qty
1	EC-1179-01	TERMINAL, FORKED TONGUE	2
2	EC-1253-01*06.0	WIRE, ELECTRICAL (WHITE)	1
3	EC-1263-01*10.0	WIRE, ELECTRICAL (BLACK)	2
4	EC-1326-05	DISCONNECT, FEMALE BLU 3/16F/I	2
5	EC-1796	SWITCH, LIMIT	1
6	EC-3023	BATTERY, 12 VOLT	1
7	EC-3024	LIGHT-ALARM	1
8	G-1100-107536	BOLT, 3/8-24 X 3-3/4" HEX HD GR 5	2
9	G-1100-109526	BOLT, 1/2-20 X 2-3/4" HEX HD GR 5	3
10	G-1155-105210	SCREW, 5/16 DIA. X 1.0" LG SOCKET HD SHOULDER	3
11	G-1159-103503	SCR, #10-32 RD HD CRS REC	1
12	G-1159-103505	SCR, #10-32 RD HD CRS REC	2
13	G-1159-105010	SCR, 1/4-20 RD HD CRS REC	3
14	G-1163-10	SCREW, 1/4-20 X 1.0 LG. HEX CUP PT SET	1
15	G-1163-12	SCR, 3/8-16 HEX CUP PT SET	1
16	G-1180-103504	SCR, #10 HEX HD TPG TYPE F	1
17	G-1202-1035	STOPNUT, #10-32 ELASTIC	2
18	G-1202-1075	STOPNUT, 3/8-24 ELASTIC	2
19	G-1202-1095	STOPNUT, 1/2-20 ELASTIC	1
20	G-1203-1095	JAMNUT, 1/2-20 ELASTIC	2
21	G-1250-1030N	FLATWASHER, #10 NARROW	3
22	G-1250-1050N	FLATWASHER, 1/4 NARROW	3
23	G-1250-1070N	FLATWASHER, 3/8 NARROW	4
24	G-1250-1090N	FLATWASHER, 1/2 NARROW	2
25	H-1424*07.0	ASSEMBLY, LANYARD	1
26	H-1424*12.0	ASSEMBLY, LANYARD	1
27	H-2762	SPRING, LIGHT DUTY DIE	3
28	H-3666	STUD, BALL	4
29	H-3668	CLIP, RETAINING	4
30	H-4053	SOCKET, BALL	4
31	H-4960	GAS SPRING	2
32	H-4961	PIN, QUICK RELEASE WITH HANDLE	2
33	H-4962	RUBBER GRIP, Ø1.0, ORANGE	2
34	H-4959	GAS SPRING	2
35	INS-1773	TEST PROCEDURE (NOT SHOWN)	1
36	R-3063-00	ADAPTER, PIVOT (P)	1
37	R-3064-PL	JAMNUT, ACME	1
38	R-3101-PL	ROD, ACME 1.5-4 TPI	1
39	R-3104-00	COUPLER, STRUT(P)	2
40	S-3134-00	BRACKET, LOAD ALARM(P)	1
41	S-3139-00	COVER, LOAD ALARM(P)	1
42	S-3141-00	COVER, MICRO SWITCH(P)	1
43	TR-1883	BASE	1
44	U-1002	WHEEL	2
45	V-1001	LABEL, MADE IN USA	1

Parts List

When ordering replacement parts/kits, please specify model, serial number and color of your unit.

Item	Part Number	Description	Qty
46	V-1197	LABEL, TRONAIR	1
47	V-1198	LABEL, TRONAIR	1
48	V-1779	LABEL, SERIAL CE NON-ELECT	1
49	V-1805	LABEL, ISO GENERAL DANGER	1
50	V-1996	LABEL, TAILSTAND CAUTION	1
51	V-1997	LABEL, TAILSTAND INSTRUCT	1
52	V-1999	LABEL, ISO HAND CRUSH	2
53	V-2000	LABEL, ISO FOOT CRUSH	1
54	Z-10571-00	MACHINING, FIRST EXTENSION TUBE (P)	1
55	Z-11610-00	WLD, CLAMP AND HANDLE (P)	1
56	Z-11611-00	WLD, TUBE CLAMP WITH HANDLE (P)	1
57	Z-11612-00	WLD, TUBE CLAMP (P)	1
58	Z-11648-00	WLD, TUBE CLAMP (P)	1
59	Z-5723	ASSEMBLY, CRADLE	1
60	Z-5962-00	WELDMENT, OUTER TUBE (P)	1
61	Z-9135-00	WELDMENT, TAILSTAND (P)	1
62	Z-9140-00	WELDMENT, SECOND EXT TUBE(P)	1
63	Z-9323-00	WELDMENT, CRADLE SUPPORT(P)	1



WARNING!

Use of different battery types may have a detrimental effect on the alarm.



APPENDIX I

Declaration of Conformity



EU Declaration of Conformity

Model Number(s) 03A5860C0000
Product Type/Name: Tailstand with Alarm
Serial Number(s): [Click or tap here to enter serial number\(s\)](#)

Declaration: Tronair has assessed the equipment described above against the Essential Health and Safety Requirements of one or more Directives. Based on this assessment, the equipment described above is deemed to comply with the directive(s) listed below.

This declaration of conformity is issued under the sole responsibility of the manufacturer.

Directives: European Machinery Directive 2006/42/EC

Standards: EN ISO 12100:2001 Safety of machinery – General principles for design
Risk assessment and risk reduction
EN 1915-1 2013 Aircraft ground support equipment – General requirements
Part 1: Basic safety requirements
EN 1915-2 2001+A1 2009 Aircraft ground support equipment – General requirements
Part 2: Stability and strength requirements, calculations and test methods

Markings: 

The technical documentation for the machinery is available from:
Mr Joel Nunn
34 Epruis Road, SW6 7UH, London, UK
Email jnunn@tronair.com

Location of Issue: Tronair, 1 Air Cargo Parkway East, Swanton, OH 43558

Certificate: EU_DoC_03A5860C0000

Identification of person empowered to sign on behalf of the Manufacturer:

Quality Assurance Representative

[Click or tap to enter a date.](#)
Date



APPENDIX II

**Rockwell Automation
Bulletin 855P/855PC**



Bulletin 855P 855PC

	WARNING	Disconnect from power source to prevent electrical shock before installing or servicing. Check power supply voltage and frequency.
	AVERTISSEMENT	Déconnecter l'alimentation avant toute opération d'installation ou de maintenance, afin d'éviter les décharges électriques. Contrôler la tension et la fréquence d'alimentation.
	WARNUNG	Schalten Sie den Strom während der Installation oder bei Wartungsarbeiten ab um einen elektrischen Schlag zu vermeiden. Prüfen Sie die Spannung und Frequenz der Stromquelle.
	AVVERTENZA	Scolligare dall'alimentazione prima dell'installazione e della messa in servizio. Controllare la tensione di alimentazione e la frequenza.
	ATENÇÃO	Desligar a alimentação antes de realizar qualquer intervenção. Verificar a tensão e frequência da alimentação.
	ADVERTENCIA	Durante el proceso de instalación o mantenimiento desconectar la tensión de alimentación para evitar descargas eléctricas. Comprobar tensión y frecuencia de alimentación.

-25°C to +60°C
(-13°F to +140°F)

Electrical Connection Raccordement Electrique Elektrischer Anschluß Collegamento Elettrico Ligações Eléctricas Conexiones Eléctricas

855P & 855PC

La	N	Lb		
X	X		-----	PULSING
	X	X	⏏	WOBBLE (65 mm ONLY)
X	X	X	_____	STEADY

Jumper
Cavalier
Brücke
Ponticello
Ponte
Puente

	WARNING	Connect AC-Neutral to N, and AC-Line to La and/or Lb as appropriate.
	AVERTISSEMENT	connecter CA-Neutre à N et CA-Ligne à La et/ou Lb selon le cas.
	WARNUNG	Verbinden Sie den Neutralleiter mit N und den Außenleiter mit La und/oder Lb.
	AVVERTENZA	Collegare Neutro-CA a N e Linea-CA a La e/o Lb come appropriato.
	ATENÇÃO	Conecte o CA Neutro ao N e a Linha CA ao La e/ou Lb, conforme necessário.
	ADVERTENCIA	Conecte Neutro-CA a N y Línea-CA a La o Lb según corresponda.

UL Type 4/4X/13 IP65

For use on a flat surface of indicated type enclosure
A utiliser sur une surface plane de l'enceinte du type indiqué
Zur Verwendung auf einer glatten Oberfläche des angegebenen Gehäusetypos
Da utilizzare su una superficie piana del tipo di custodia indicato
Para uso sobre la superficie plana de un envoltente del tipo indicado
Para uso em superfície plana no tipo de protecção indicada

45mm / 65mm:

Volume Adjust
Commande Volume
Regelung der Lautstärke
Regolazione del Volume
Ajuste do volume
Ajuste del Volumen

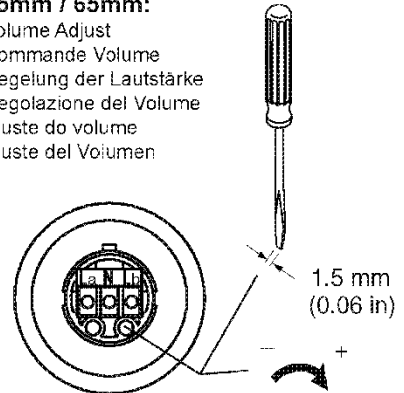

	WARNING	Do not apply voltage across La and Lb as device may be damaged.
	AVERTISSEMENT	ne pas appliquer de tension à La/Lb ou vous risquez d'endommager le dispositif.
	WARNUNG	Keine Spannung an Klemme La und Lb anlegen, da dadurch das Gerät zerstört werden kann.
	AVVERTENZA	non applicare corrente a La/Lb poiché si potrebbe danneggiare il dispositivo.
	ATENÇÃO	Não aplique voltagem a La/Lb, pois isso pode danificar o dispositivo.
	ADVERTENCIA	No aplicar corriente a La/Lb ya que puede dañarse el dispositivo.

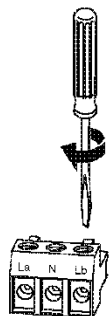

.56 N•m
(5 lb-in)

7 mm
(0.28 in)

Max. 2.5 mm²
(Max. #14 AWG)

