

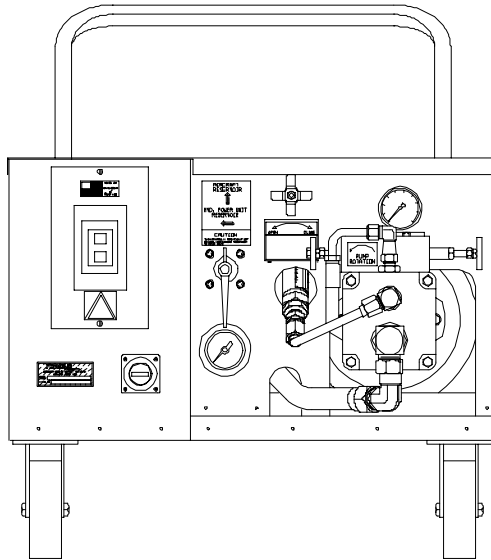

Operation & Service Manual



Model: 05-7015 Series Hydraulic Power Unit

05/2002 - AA - Rev. 21

Includes Illustrated Parts Lists

Tronair, Inc.

*1740 Eber Road
Holland, Ohio 43528-9794
USA*

Telephone: (419) 866-6301 • 800-426-6301

Fax: (419) 867-0634

Web Site: www.tronair.com E-mail: mail@tronair.com

**Model: 05-7015 Series
Hydraulic Power Unit**

TABLE OF CONTENTS

PAGE

Front Panel Controls.....	1
Internal Components	2
Hydraulic Schematic	3
Electrical Schematic	4
1.0 General Description.....	5
2.0 Technical Specifications.....	5
3.0 Preparation For Use.....	6
3.1 Servicing Reservoir	6
3.2 Connecting Electrical Leads	6
4.0 Operation	6
4.1 General Comments	6
4.2 Preliminary Adjustments And Operations.....	7
4.3 Sample Valve.....	9
4.4 Bleeding Air From System	9
4.5 Abbreviated Operating Instructions.....	10
4.6 Options	11
5.0 Maintenance	11
5.1 General Maintenance.....	11
5.2 Filter Maintenance.....	12
5.3 Selector Valve Maintenance.....	12
5.4 Lubrication	12
5.5 Storage.....	12
6.0 Troubleshooting.....	12
6.1 No Flow Or Pressure	12
6.2 Fluctuating Pressure Or Flow	12
6.3 Unit Overheats.....	13
6.4 Loss Of Flow In Closed Loop	13
6.5 External Leakage From Selector Valve.....	13
Parts List Index.....	14

APPENDIX	I	Instrument Certification Notice
APPENDIX	II	Lincoln Motor Manual
APPENDIX	III	Oilgear Manuals
APPENDIX	IV	MSDS (Hydraulic Fluid)

**Model: 05-7015 Series
Hydraulic Power Unit**

Front Panel Controls

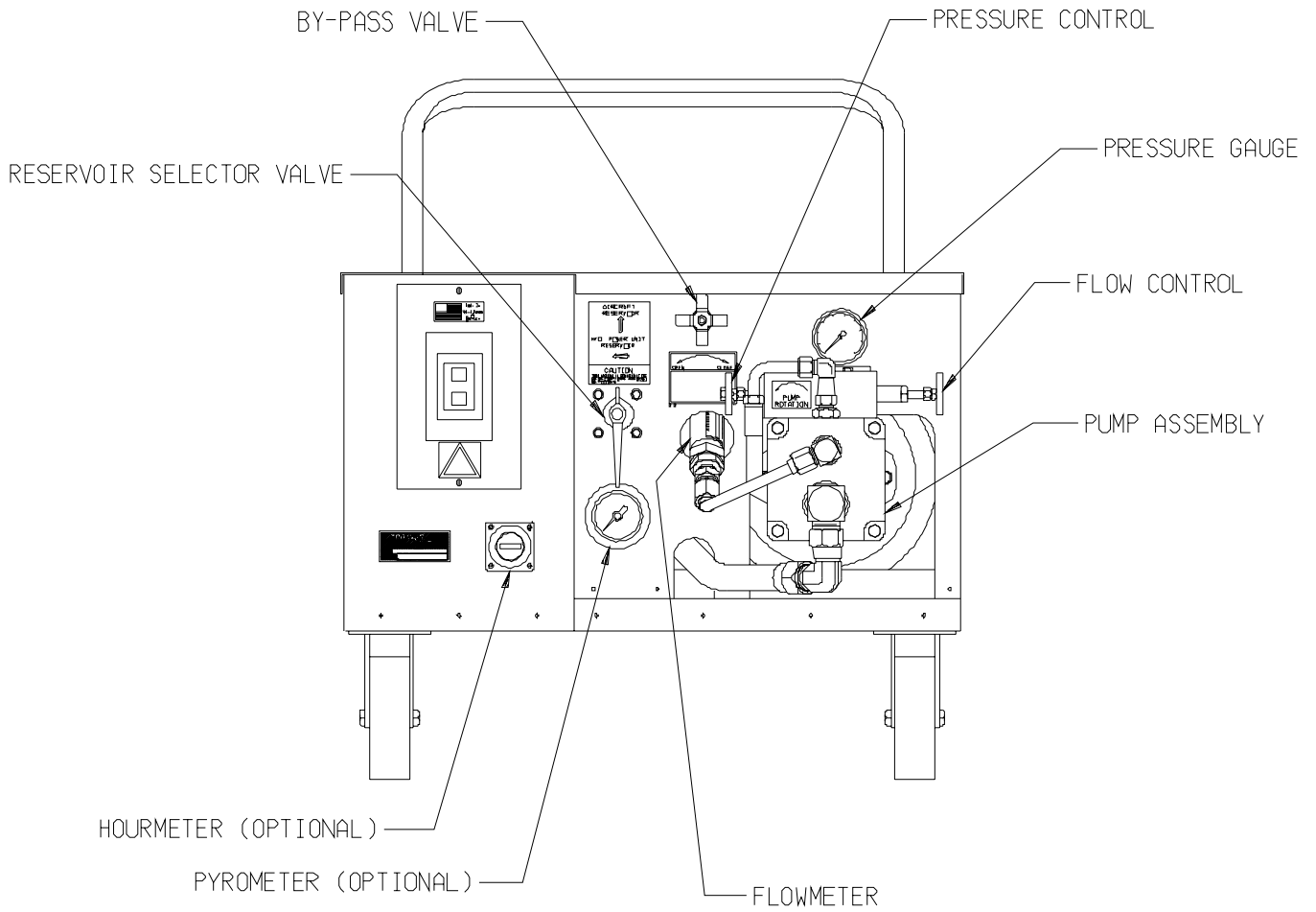

**Model: 05-7015 Series
Hydraulic Power Unit**

Internal Components

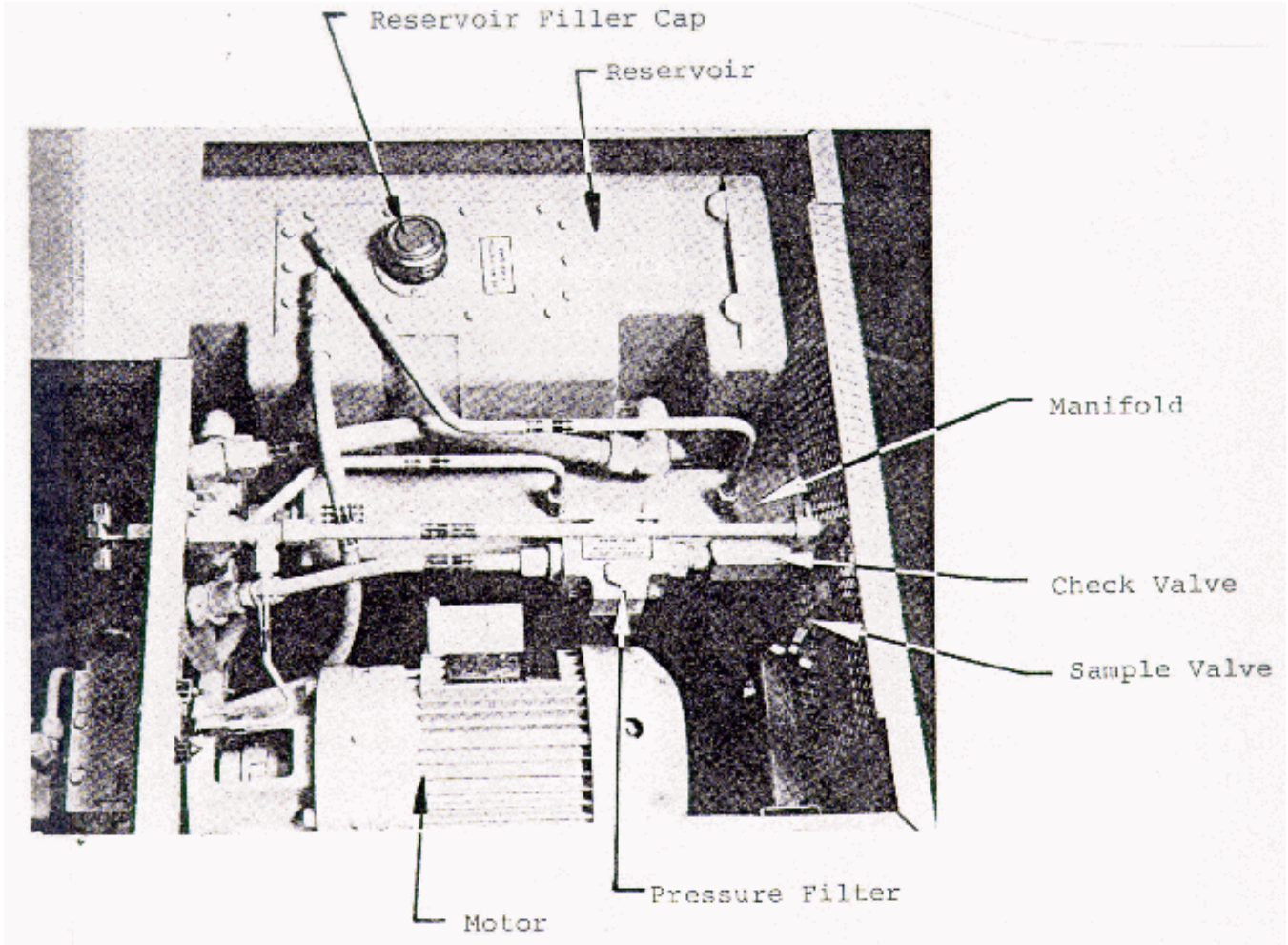

Model: 05-7015 Series
Hydraulic Power Unit

Hydraulic Schematic

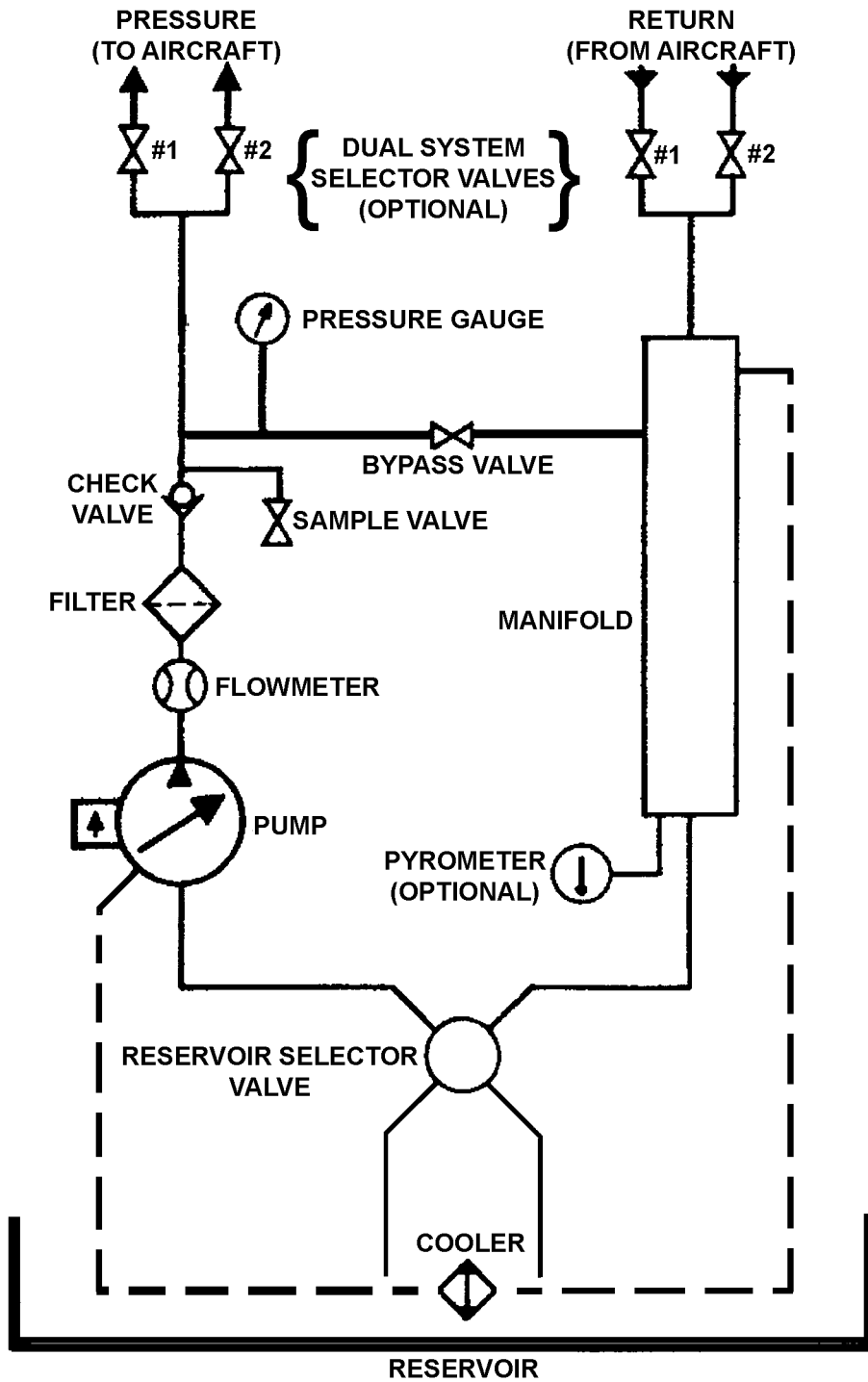

TRONAIR

05/2002 - AA - Rev. 21

Model: 05-7015 Series
Hydraulic Power Unit

Electrical Schematic

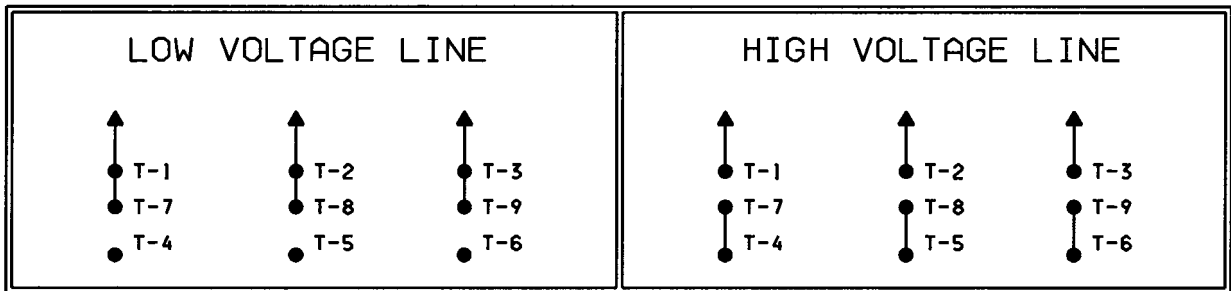
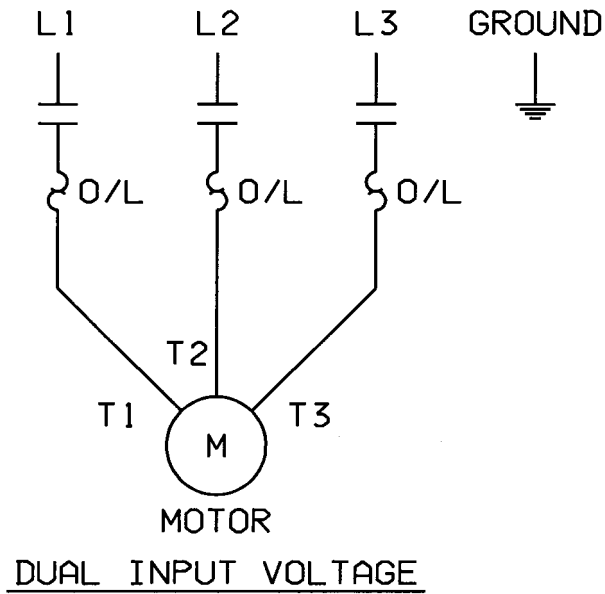

Model: 05-7015 Series Hydraulic Power Unit

1.0 GENERAL DESCRIPTION

The Tronair Hydraulic Power Unit (HPU) provides a source of clean, pressurized hydraulic fluid for performing required aircraft maintenance.

Some important features are:

- Pressure compensated pump with integral pressure and flow controls
- 10 gallon reservoir
- Bypass valve
- Cooler located inside reservoir
- Manual starter with overload protection
- Non-bypass filter with 3 micron filter element

2.0 TECHNICAL SPECIFICATIONS

Hydraulic

Fluid:	05-7015-1100	MIL-H-5606
	05-7015-1200	MIL-PRF-83282D
Pressure Range:	250 - 3000 PSI	
Flow Range:	0-6 GPM	
Filtration:	3 Micron Absolute	
Reservoir Capacity:	10 Gallons	

Electrical

Power Requirements:	3 Phase	
60 HZ	50 HZ	
15 AMPS @ 208 VAC	15 AMPS @ 220 VAC	
13.6 AMPS @ 230 VAC	7.5 AMPS @ 380, 415, 440 VAC	
6.8 AMPS @ 460 VAC		
5.4 AMPS @ 575 VAC		

Mechanical

Dimensions: 35 inches long x 30 inches Wide x 24 inches High
Weight: 400 lbs

Model: 05-7015 Series Hydraulic Power Unit

3.0 PREPARATION FOR USE

The HPU is shipped completely assembled and only the following steps are required to make the unit operational.

3.1 SERVICING RESERVOIR

Remove the sheet metal top cover and fill the reservoir with the correct fluid until fluid level is slightly above the minimum oil level mark. Since a case drain cooler is located in the HPU reservoir, it is important that this fluid level be maintained in order to prevent excessive heat buildup.

3.2 CONNECTING ELECTRICAL LEADS

Install plug onto the electrical cord and check for proper motor rotation by "bumping" the On-Off switch. Correct motor rotation is indicated by an arrow on pump motor adapter. If rotation is not correct, change any two of the three input leads inside the on-off switch box or at the plug.

WARNING!

Balanced three phase voltage must be available to prevent overheating and damage to the motor. Voltage unbalanced between phases occurs when the voltages differ from one another. Some reasons for imbalance are:



- 1. Unequal loading of each phase**
- 2. Poor connections in the supply**
- 3. Single phase condition caused by blown fuses or bad connections**

If these conditions occur in the incoming power system, a protective device, such as a voltage monitor, should be installed on the machine to prevent motor damage.

4.0 OPERATION

Due to the complexity, differences, and ongoing changes in aircraft hydraulic systems, no attempt has been made to relate to any specific aircraft operation. It is suggested that this manual and the HPU be studied thoroughly in order to obtain optimum benefit of the various features. By combining an understanding of the HPU and the aircraft hydraulic system, many services not mentioned in this manual may be performed. Refer to the Hydraulic Schematic, Front Panel Controls, and Internal Components pages for clarification while reading this manual.

4.1 GENERAL COMMENTS

Most questions or problems concerning hydraulic power units are usually caused by improper training or understanding of hydraulics. The following comments are given to aid in obtaining maximum benefits from the hydraulic power unit.

A. Training

Be sure that all personnel that will use the machine read the operating manual and receive training. We encourage customers to call Tronair to discuss any operating or testing requirements.

4.1 General Comments continued on following page.

**Model: 05-7015 Series
Hydraulic Power Unit**

4.1 GENERAL COMMENTS

B. Use of the HPU Reservoir

It is suggested that the integral reservoir be used whenever possible. Use of this reservoir eliminates any possibility of cavitating the pump. Most complaints of pump noises are due to fluid restrictions in the aircraft systems when using the aircraft reservoir. Also, if the integral reservoir is used, the HPU will run considerably cooler. This occurs because the pump case drain oil is directed to the reservoir instead of the pump return. The only compromise in using the HPU reservoir is that the aircraft system reservoir must be serviced after testing, which is standard procedure.

4.2 PRELIMINARY ADJUSTMENTS AND OPERATIONS

The following are basic to the operation of the HPU and should be thoroughly understood. The pressure and flow controls have lock nuts to prevent rotation of the control shafts during operation. These nuts should be moved away from the pump during adjustments of flow or pressure in order to eliminate binding of the control shafts.

A. Flow Control Adjustment:

1. Open bypass valve.
2. Select "Hydraulic Power Unit" position with reservoir selector valve.
3. Start HPU.
4. Adjust flow control for maximum desired flow. Observing the flowmeter, read flow (gallons per minute) directly from flowmeter scale. Be sure the control shaft lock nut is loose during adjustment. Tighten after adjustment to maintain setting.

B Pressure Control Adjustment:

1. Open bypass valve.
2. Select "Hydraulic Power Unit" position with reservoir selector valve.
3. Start HPU.
4. Close bypass valve.
5. Adjust pressure control for desired pressure. Be sure the control shaft lock nut is loose during adjustment. Tighten after adjustment to maintain setting.

NOTE: *Once the flow and pressure controls have been adjusted, it is not necessary to change these fittings after each operation unless desired.*

4.2 Preliminary Adjustments and Operation continued on following page.

**Model: 05-7015 Series
Hydraulic Power Unit**

4.0 OPERATION

4.2 PRELIMINARY ADJUSTMENTS AND OPERATION

C. Reservoir Selector Valve Operation

Operation of the reservoir selector valve allows the operator to select either the aircraft reservoir (closed loop) or the HPU reservoir (open loop).



CAUTION!

The reservoir selector valve should only be operated when the HPU is NOT running. The operation of the reservoir selector valve should be done prior to starting the HPU.

1. Aircraft Reservoir Position (Closed Loop)

In this position, the HPU is dependent on the aircraft reservoir and system for an adequate supply of fluid. Cavitation, due to an inadequate fluid supply from the aircraft, may be indicated by erratic indication of the system pressure gauge or flowmeter. Usually, the aircraft fluid supply will be restricted due to small return oil lines in the aircraft. Sometimes this problem can be minimized or eliminated by pressurizing the aircraft reservoir with air.



CAUTION!

If the aircraft is pressurized, DO NOT exceed the aircraft manufacturer's recommendation.

If the aircraft reservoir cannot be pressurized or the cavitation persists, decrease the flow control setting until the cavitation is eliminated.

2. HPU Reservoir Position (Open Loop)

In this position, the HPU reservoir supplies oil to the pump and accepts return oil from the aircraft. It is desirable to operate the HPU in this mode since it eliminates any possibility of cavitation.

Since the HPU reservoir is vented to atmosphere and the aircraft is at a higher level, it is normal for the aircraft reservoir to drain into the HPU reservoir. It is, therefore, necessary to be sure that sufficient room is available in the HPU reservoir to accommodate the additional fluid.



CAUTION!

The aircraft system reservoir must be serviced after completion of operational testing.

In the "HPU Reservoir" position, faster landing gear swings are usually possible since there is no restrictions to flow at the pump inlet.

On most aircraft, the aircraft reservoir may usually be serviced by disconnecting the return hose. Normally servo leakage or operation of a hydraulic component will allow some flow to the aircraft reservoir. Caution should be observed if this method is used.

4.2 Preliminary Adjustments and Operation continued on following page.

**Model: 05-7015 Series
Hydraulic Power Unit**

4.2 PRELIMINARY ADJUSTMENTS AND OPERATION



WARNING!

When using the HPU reservoir, it may be possible to overfill the aircraft reservoir if several landing gear swings are done in a short time period.

Always wait approximately 15 seconds between gear swings to allow the aircraft reservoir to drain into the HPU. Also, do not change the reservoir selector valve position while the machine is running.

D. Bypass Valve Operation

The bypass valve is used for unloading the pump flow in conjunction with the flowmeter.

1. Start Up Operation:

The bypass valve should be opened prior to starting the HPU in order to allow the motor to start under a no load condition.

2. Shut Down Operation:

Prior to shutdown, the bypass valve may be opened to bleed off any residual system pressure.



CAUTION!

Excessive heat, which could damage machine components, will be generated if the bypass valve is partially opened or is used for regulating flow or pressure.

- Use the flow and pressure controls for regulation.
- Use the bypass valve for unloading the system.

4.3 SAMPLE VALVE

A sample valve is provided on the rear of the unit to obtain a fluid sample for analysis or inspection. In order to obtain a representative fluid sample, it is suggested that American National Standard number B93.19-1972 be followed.

4.4 BLEEDING AIR FROM SYSTEM

Rapid fluctuations of the pressure gauge and flowmeter are indications of cavitation or entrapped air in the hydraulic lines and/or components. Air may enter the system when:

- Operating the unit with insufficient oil in the reservoir.
- Changing a component on the aircraft
- Changing the hose connections and/or couplings

4.4 *Bleeding Air From System continued on following page.*

**Model: 05-7015 Series
Hydraulic Power Unit**

4.0 OPERATION

4.4 BLEEDING AIR FROM SYSTEM

To Easily Purge The Unit of Air:

1. Fill reservoir to recommended level.
2. Open bypass valve.
3. Place reservoir selector valve in "Hydraulic Power Unit" position.
4. Start unit and adjust flow control to maximum position.
5. Run unit for 5 minutes and shut off.
6. If additional bleeding is required, proceed with the following steps.
 - a. Connect the pressure and return hoses together. (Kits containing the necessary fitting(s) are available from Tronair)
 - b. If the unit is equipped with pressure and return ball valves, open the ball valves prior to starting the unit.



WARNING!

Failure to open the return ball valves will cause hose or valve rupture. Property damage and personal injury can result.

- c. Place the reservoir selector valve in the "Hydraulic Power Unit" position.
- d. Open the bypass valve on the instrument panel
- e. Start unit and adjust flow control to maximum position.
- f. Close the bypass valve and allow the unit to run for 5 minutes.

Under some conditions where a large amount of air has entered the system, the pump may not be able to draw an initial prime and will not pump. If this occurs, it may be necessary to fill the pump inlet line with fluid.

4.5 ABBREVIATED OPERATING INSTRUCTIONS

These instructions may be used for fast reference after a thorough understanding of the HPU operation has been achieved.

A. Initial Adjustments:

1. Set flow control (See Section 4.2.a).
2. Set pressure control (See Section 4.2.b).

B. Prior to Starting:

1. Select reservoir valve position.
2. Open bypass valve.

C. Operation:

1. Start the HPU.
2. Close bypass valve.

D. Shut Off:

1. Open bypass valve.
2. Stop the HPU.

4.0 Operation continued on following page.

Model: 05-7015 Series Hydraulic Power Unit

4.0 OPERATION

4.6 OPTIONS

The following options are available on some models of hydraulic power units. Refer to the appropriate option description for operation information.

A. Dual System Operation

The dual system option allows control of fluid flow to aircraft with two hydraulic systems. The systems consist of two sets of hoses and valves located in the pressure and return systems. The valves are mounted on the rear of the hydraulic power unit and are of the 90 degree ball type. The valves are open when the operating handle is in line with the valve.

Although both systems may be operated simultaneously, usually only one system is required at any one time. If both valve sets are open simultaneously, the pump output will be divided between the two systems. Also, cross flow between aircraft reservoirs may occur if a reservoir level or pressure differential exists. **Select valve positions prior to starting machine.**

To Operate the Dual System:

1. Before starting machine, open pressure and return valves of the **same system**.



WARNING!

Assure pressure and return hoses of the same system are paired and used together.

2. After completing tests on one system, shut the machine off before selecting the second system.



WARNING!

Never open or close dual system valves without shutting off the hydraulic power unit. Damage to the aircraft system or reservoir may result if either return line valve is closed while the machine is running.

3. If equipped with the **dual system crossover check** option, separate pressure gauges are located after each system pressure shut off valve. This allows bleed down pressures to be read when the pressure valves are closed. Follow aircraft manufacturer's instructions.

5.0 MAINTENANCE

5.1 GENERAL MAINTENANCE

The hydraulic power unit should be maintained in a safe and clean condition at all times.

- Locate and correct the source of any and all leaks.
- Inspect hoses and electrical cord periodically for damage and wear. Replace as required.

5.0 Maintenance continued on following page.

**Model: 05-7015 Series
Hydraulic Power Unit**

5.0 MAINTENANCE

5.2 FILTER MAINTENANCE

The main pressure filter has a replaceable element that is not cleanable. It is recommended that this filter be changed after every **25 hours of operation, annually**, or whenever a **reduced maximum flow** is noticed. Refer to the parts list for the correct filter element number.

5.3 SELECTOR VALVE MAINTENANCE

The Reservoir Selector Valve has been assembled with a special grease (Tronair #H-2132) that is compatible with Skydrol. It is recommended that this valve be disassembled and re-lubed every two (2) years, or if there is any sign of external leakage.

5.4 LUBRICATION

The swivel casters are equipped with grease fittings which should be lubricated annually.

5.5 STORAGE

In the event that the HPU will not be used for 12 months or longer, the reservoir may be drained. The unit should then be appropriately covered in order to maintain cleanliness.

6.0 TROUBLESHOOTING

6.1 NO FLOW OR PRESSURE

- A. Flow control set too low:
 - Increase flow setting.
- B. Motor running in wrong direction:
 - See Section 3.0, "Preparation for Use".
- C. Insufficient oil in reservoir:
 - See Section 3.0, "Preparation for Use".
- D. Air in hydraulic lines:
 - See Section 4.4, "Bleeding Air From System".
- E. Faulty pump:
 - Repair or replace pump.

6.2 FLUCTUATING PRESSURE OR FLOW

- A. Pump cavitation:
 - See Section 4.2.C.1, "Aircraft Reservoir Position".
- B. Air in hydraulic lines:
 - See Section 4.4, "Bleeding Air From System".

6.0 Trouble Shooting continued on following page.

**Model: 05-7015 Series
Hydraulic Power Unit**

6.0 TROUBLESHOOTING

6.3 UNIT OVERHEATS

- A. Low fluid level in reservoir:
 - See Section 3.0, "Preparation for Use".
- B. Running unit for long time periods without operating aircraft components:
 - Cycle landing gear or other components periodically or allow unit to cool.
- C. Bypass Valve partially open:
 - See Section 4.2.D, "Bypass Valve Operation".

NOTE: *Running time under deadhead condition can be increased substantially by selecting the "Hydraulic Power Unit" position; reservoir selector valve.*

When a pressure compensated pump is required to hold pressure without any flow delivery (dead headed condition) it is normal for the pump case drain flow and temperature to increase. By selecting the "Hydraulic Power Unit" position of the selector valve all of the oil in the reservoir is utilized for cooling.

6.4 LOSS OF FLOW IN CLOSED LOOP

- A. Leaking over reservoir selector valve:
 - Valve must be disassembled and thoroughly cleaned with alcohol. Re-lube with grease (Tronair #H-2132) before reassembled.

6.5 EXTERNAL LEAKAGE FROM SELECTOR VALVE

- A. Leaking out the front of the reservoir selector valve:
 - Valve must be disassembled and thoroughly cleaned with alcohol. Re-lube with grease (Tronair #H-2132) before reassembled.

**Model: 05-7015 Series
Hydraulic Power Unit**

Parts List Index

<u>DESCRIPTION</u>	<u>PAGE</u>
External Components	15
Internal Components	16
Electrical Components	17
Reservoir Selector Valve	18
Reservoir Sub-Assembly	19
Pump/Motor Assembly.....	20
Filter Assembly	21
Bypass Valve	22
Sample Valve	23
Option 6—Dual System	24
Option 7—Pyrometer	25
Option 8—Hourmeter.....	26
Option 14—Crossover Check Valve	24
Option 16—Return Filter Assembly	27
Option 24—Reservoir Return Hose	28

**Model: 05-7015 Series
Hydraulic Power Unit**

External Components

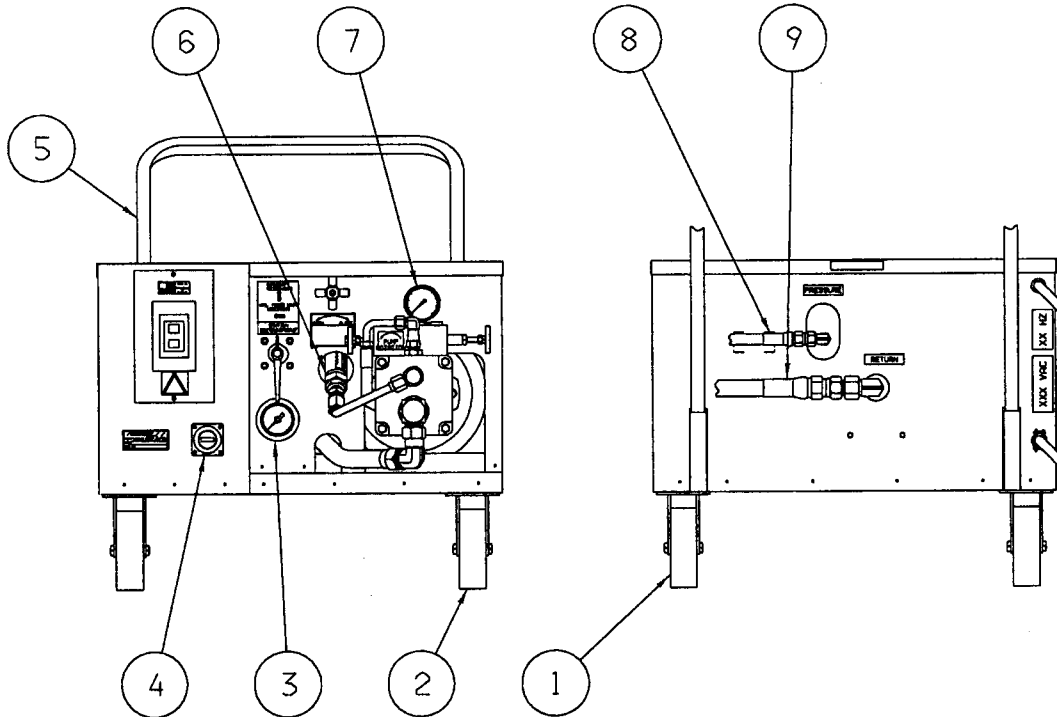

ITEM	PART NUMBER	DESCRIPTION	QTY
1	U-1057	Caster (Swivel)	2
2	U-1056	Caster (Rigid)	2
3	Option 7-See page 29	Pyrometer	1
4	Option 8-See page 30	Hourmeter	1
5	TS-1482-01	Handle	1
6	HC-2150	Flow meter	1
7	HC-1386	Gauge, Pressure	1
8	TF-1037-1-180	Assembly, Pressure Hose	1
9	TF-1039-1-180	Assembly, Return Hose	1

Model: 05-7015 Series
Hydraulic Power Unit

Internal Components

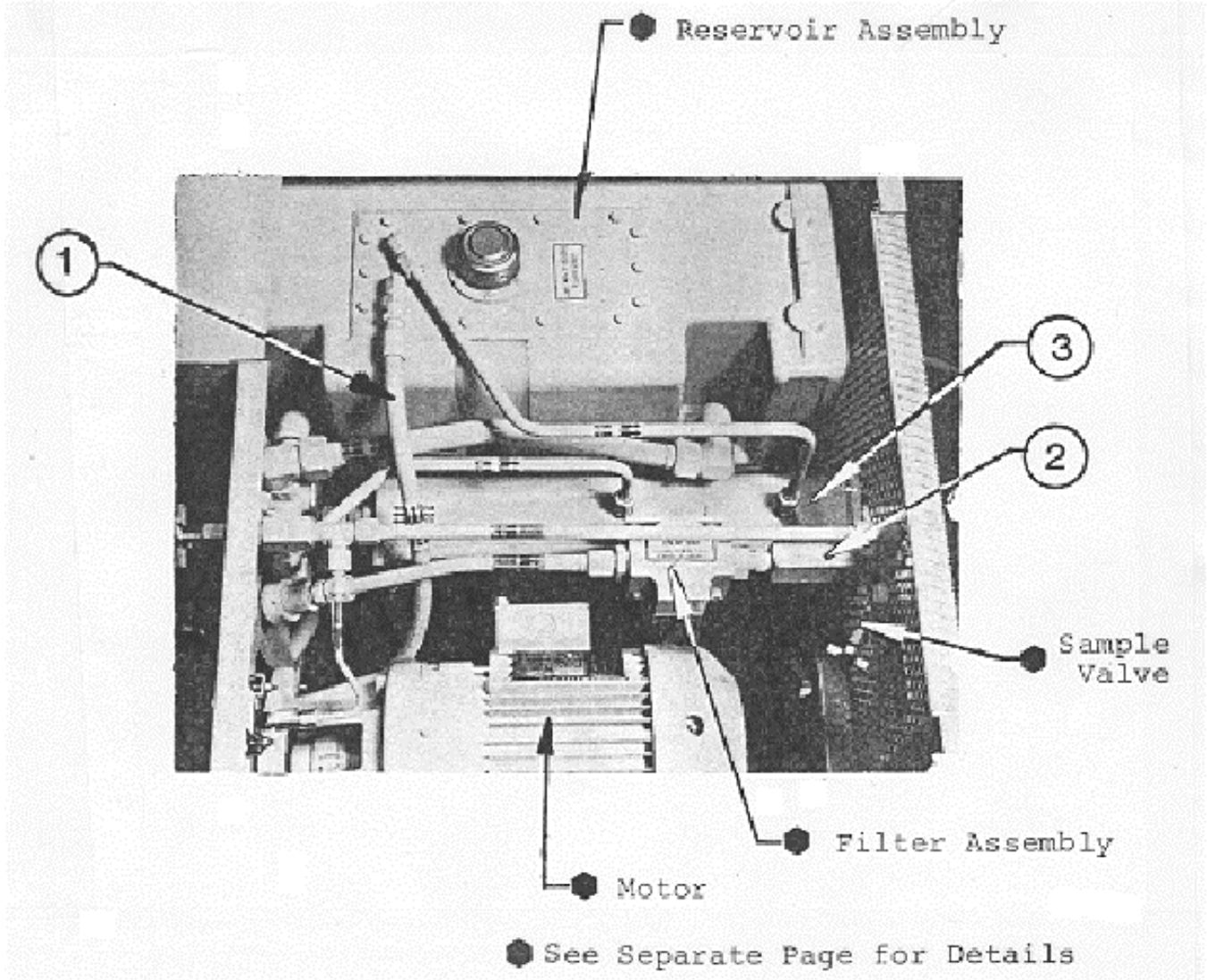

ITEM	PART NUMBER	DESCRIPTION	QTY
1	TF-1054-04*31.8	Assembly, Pump Case Hose	1
2	HC-1058	Valve, Check	1
3	Z-1834	Manifold	1

TRONAIR

05/2002 - AA - Rev. 21

**Model: 05-7015 Series
Hydraulic Power Unit**

Electrical Components

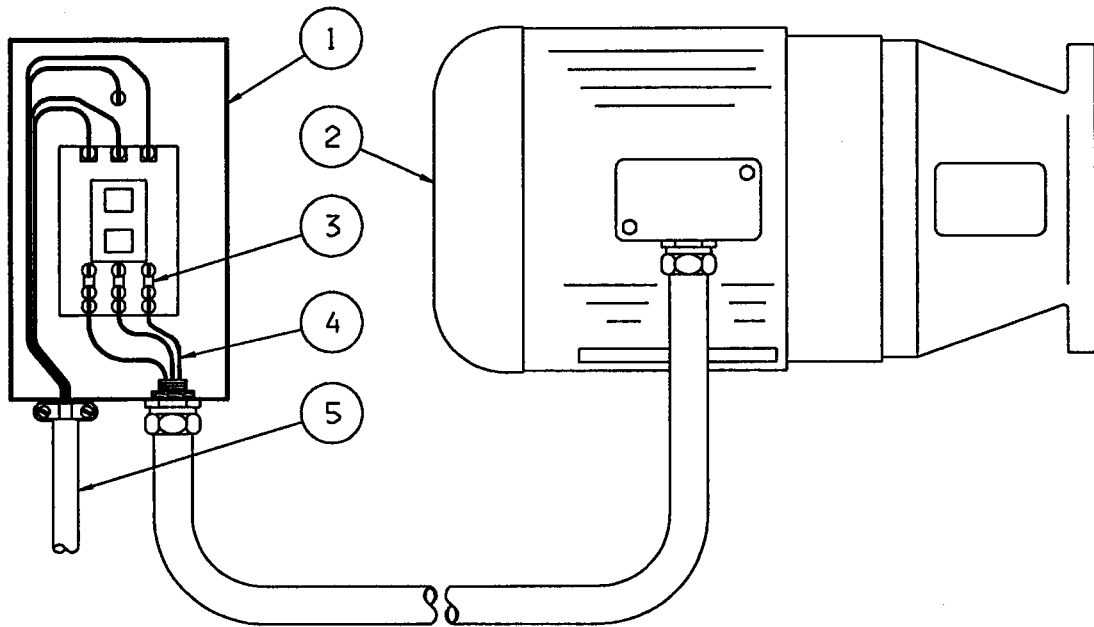

VAC @ 60Hz	(1) STARTER SWITCH	QTY	(2) MOTOR	QTY	(3) HEATER	QTY	(4) WIRE	QTY	(5) POWER CORD	QTY
208	EC-1065	1	EC-1186-04	3	EC-1202-W-56	1	EC-1252-01*43	1	EC-1170-01	1
230	EC-1065	1	EC-1186-05	3	EC-1202-W-55	1	EC-1252-01*43	1	EC-1170-01	1
380	EC-1065	1	EC-1186-05	3	EC-1202-W-50	1	EC-1252-01*43	1	EC-1170-01	1
460	EC-1065	1	EC-1186-05	3	EC-1202-W-48	1	EC-1252-01*43	1	EC-1170-01	1
575	EC-1065	1	EC-1186-06	3	EC-1202-W-45	1	EC-1252-01*43	1	EC-1170-01	1

VAC @ 50Hz	(1) STARTER SWITCH	QTY	(2) MOTOR	QTY	(3) HEATER	QTY	(4) WIRE	QTY	(5) POWER CORD	QTY
200	EC-1065	1	EC-1186-05	3	EC-1202-W-56	1	EC-1252-01*43	1	EC-1170-04	1
220	EC-1065	1	EC-1186-05	3	EC-1202-W-56	1	EC-1252-01*43	1	EC-1170-04	1
380	EC-1065	1	EC-1186-05	3	EC-1202-W-49	1	EC-1252-01*43	1	EC-1170-01	1
415	EC-1065	1	EC-1186-05	3	EC-1202-W-49	1	EC-1252-01*43	1	EC-1170-01	1
440	EC-1065	1	EC-1186-05	3	EC-1202-W-49	1	EC-1252-01*43	1	EC-1170-01	1

Reservoir Selector Valve

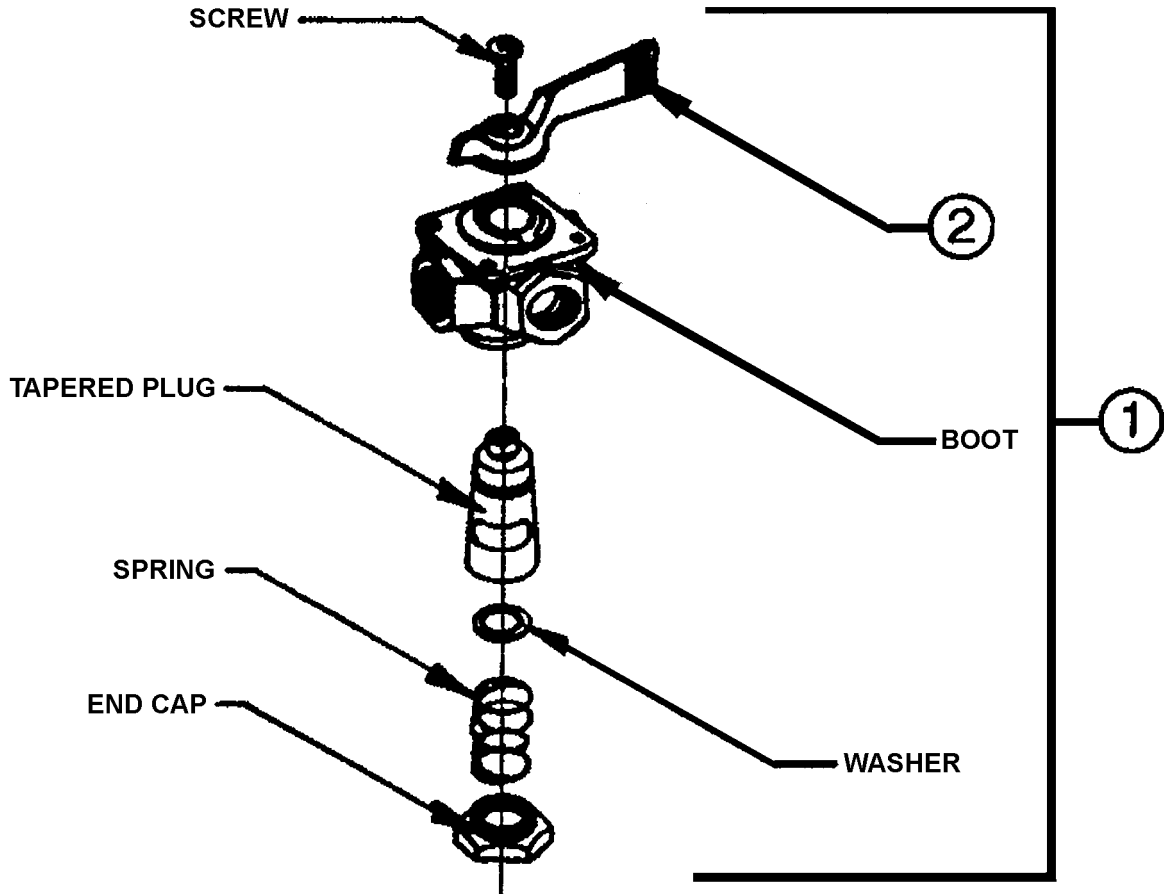

ITEM	FLUID	PART NUMBER	DESCRIPTION	QTY
1	Phosphate Ester	HC-1074	Assembly, Valve	1
		HC-1742	Valve, Selector	1

VALVE REPLACEMENT PARTS

2	N/A	HC-1075	Handle, Valve	1
---	-----	---------	---------------	---

NOTE: For replacement of parts other than what is listed, a complete valve (Item 1) must be purchased.

Model: 05-7015 Series
Hydraulic Power Unit

Reservoir Sub-Assembly

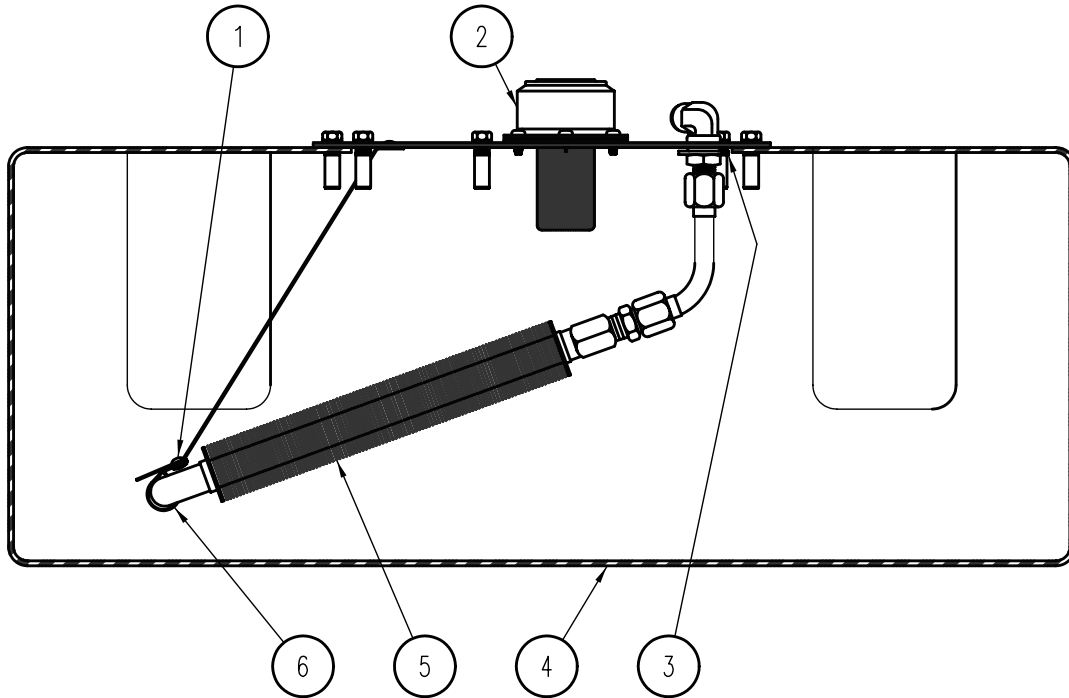

ITEM	PART NUMBER	DESCRIPTION	QTY
1	G-1351-04	Rivet, 1/8 Open-End Steel	4
2	HC-1030	Assembly, Filler/Breather	1
3	HC-2010-908	O-ring	2
4	K-3708	Kit, Reservoir	1
5	HC-1878	Cooler	1
6	H-1721-04	Clamp	1

**Model: 05-7015 Series
Hydraulic Power Unit**

Pump/Motor Assembly

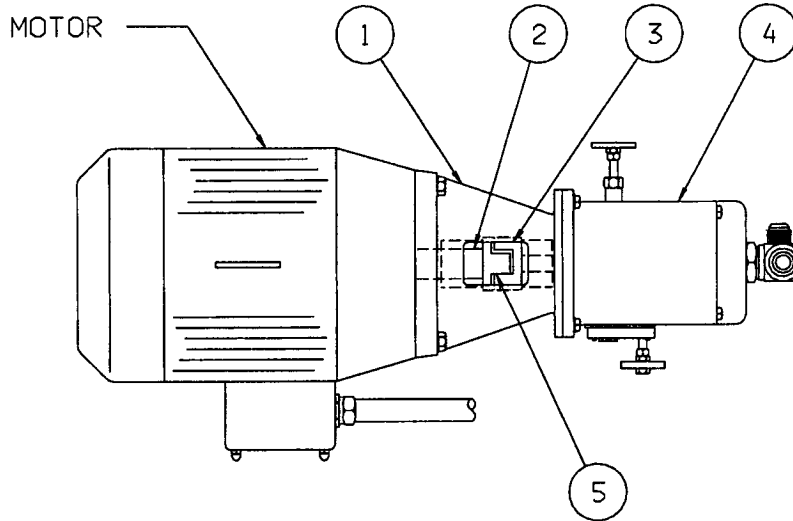

ITEM	PART NUMBER	DESCRIPTION	QTY
1	HC-1393-11	Mount, Pump/Motor	1
2	H-2224-03	Coupling, Body (Motor)	1
3	H-2224-01	Coupling, Body (Pump)	1
*4	K-1703 (MB)	Pump, Hydraulic with Hardware	1
	Z-4222 (PE)	Pump, Hydraulic with Hardware	1
5	H-2227	Coupling, Spider	1

PUMP REPLACEMENT PARTS

	HC-1543	Shaft Seal	1
*	K-1994	Kit, Gaskets and O-rings	1

NOTE: All bolts are Grade 5.

* See pump manufacturer's service booklet for servicing of Item 4 and additional repair kits.

Model: 05-7015 Series
Hydraulic Power Unit

Filter Assembly

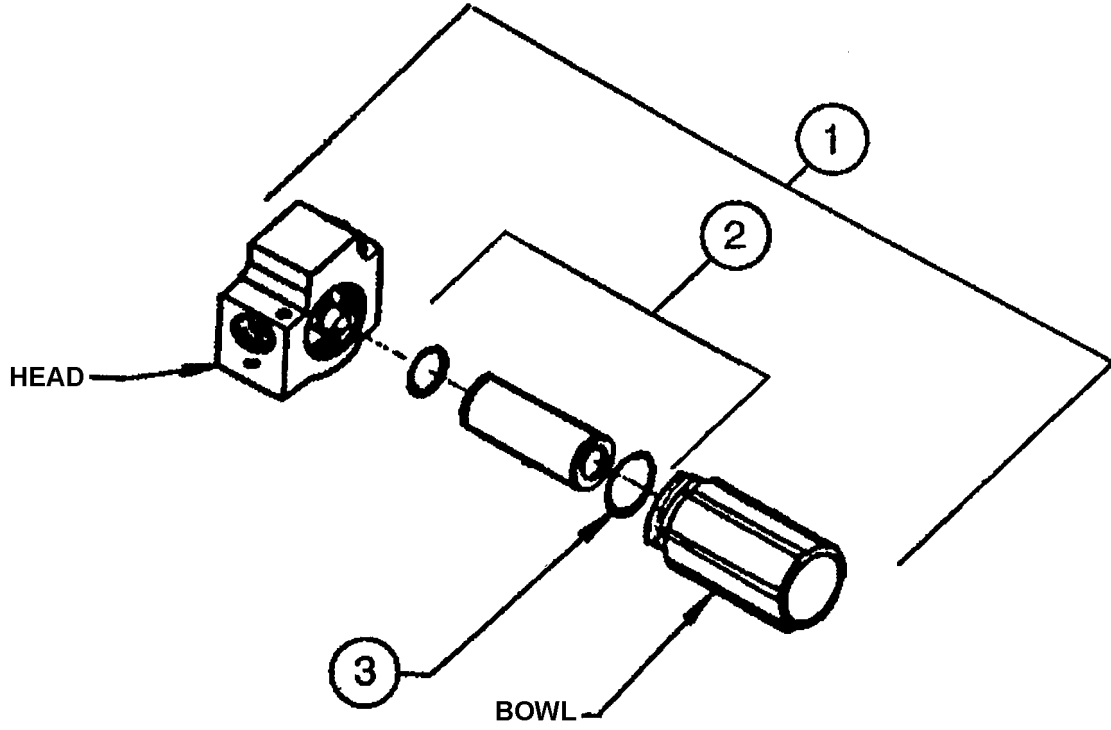

ITEM	PART NUMBER	DESCRIPTION	QTY
1	HC-1083	Assembly, Filter (Complete)	1
<u>FILTER REPLACEMENT PARTS</u>			
2	K-1414	Kit, Filter Element	1
*3	HC-2000-138	O-ring, Bowl	1

* Item 3 is included with Item 2.

Model: 05-7015 Series
Hydraulic Power Unit

Bypass Valve

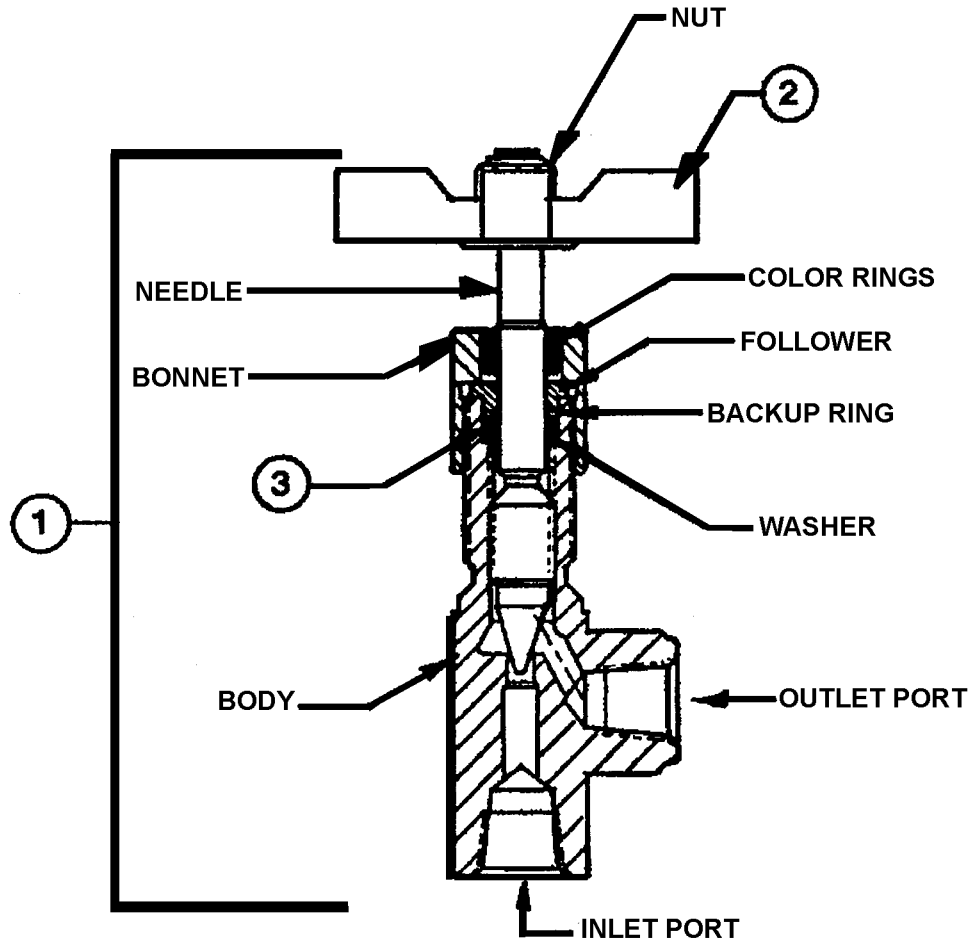

ITEM	PART NUMBER	DESCRIPTION	QTY
1	HC-1056-1	Assembly, Valve	1

VALVE REPLACEMENT PARTS

2	HC-1076	Handle, Valve	1
3	HC-2000-012	O-ring	1

TRONAIR

05/2002 - AA - Rev. 21

Model: 05-7015 Series
Hydraulic Power Unit

Sample Valve

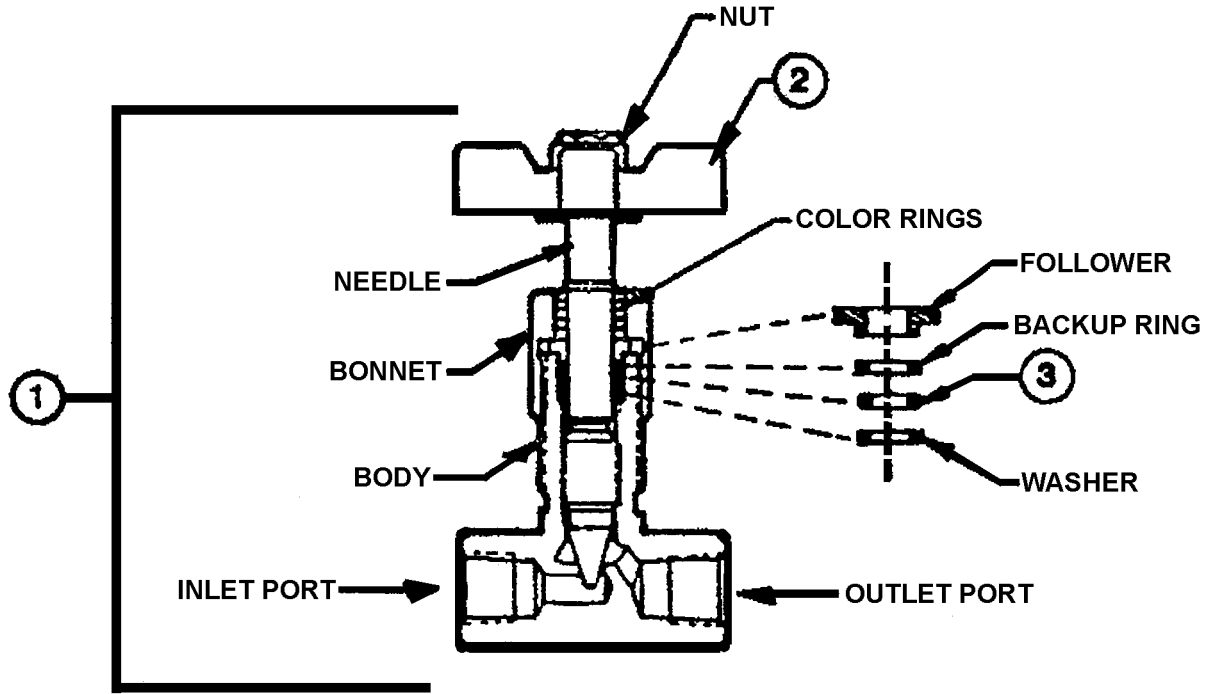

ITEM	PART NUMBER	DESCRIPTION	QTY
1	HC-1202-1	Assembly, Valve	1
<u>VALVE REPLACEMENT PARTS</u>			
2	HC-1203	Handle, Valve	1
3	HC-2000-010	O-ring	1

**Model: 05-7015 Series
Hydraulic Power Unit**

**Option 6—Dual System
Option 14—Crossover Check**

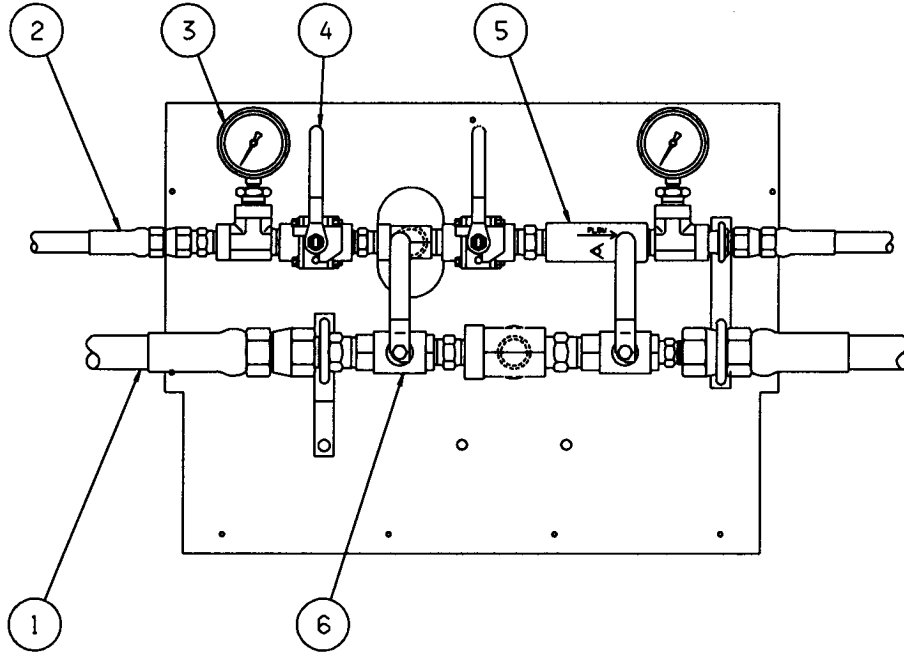

ITEM	FLUID	PART NUMBER	DESCRIPTION	QTY
1	Mineral Base	TF-1039-01*180	Assembly, Return Hose	2
	Phosphate Ester	TF-1041-01*180	Assembly, Return Hose	2
2	Mineral Base	TF-1037-01*180	Assembly, Pressure Hose	2
	Phosphate Ester	TF-1041-09*180	Assembly, Pressure Hose	2
3	N/A	HC-1042	Gauge, Pressure	2
4	Mineral Base	HC-1097	Valve, Pressure Ball	2
	Phosphate Ester	HC-1654-03	Valve, Pressure Ball	2
5	N/A	HC-1059	Valve, Check	1
6	N/A	HC-1425-04	Valve, Return Ball	2

Model: 05-7015 Series
Hydraulic Power Unit

Option 7—Pyrometer

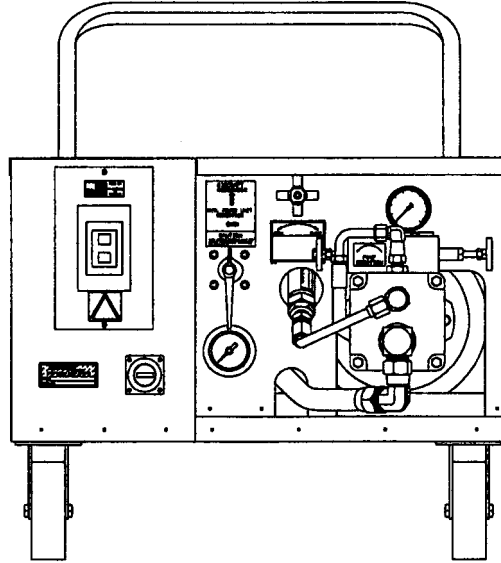

CALIBRATION ADJUSTMENT SCREW

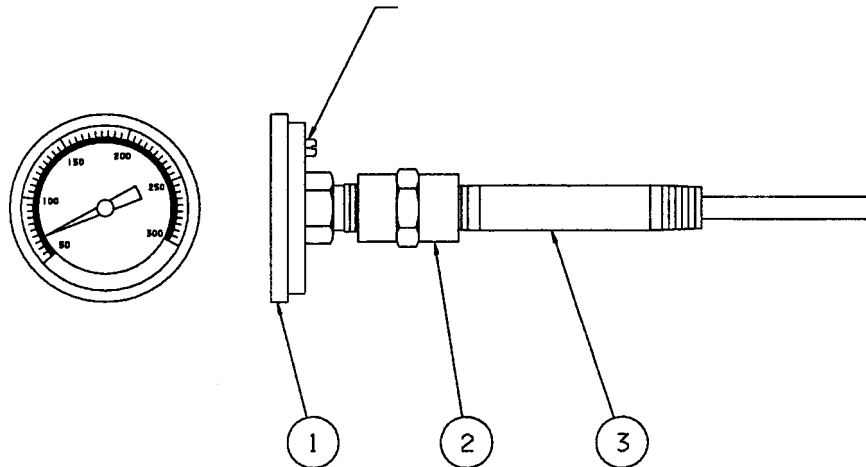

ITEM	PART NUMBER	DESCRIPTION	QTY
1	HC-1093	Pyrometer	1
2	N-2204-04-S	Connector, Pipe	1
3	N-2237-02-30	Nipple, 1/4 NPT x 3" long Pipe	1

TRONAIR

05/2002 - AA - Rev. 21

Model: 05-7015 Series
Hydraulic Power Unit

Option 8—Hourmeter

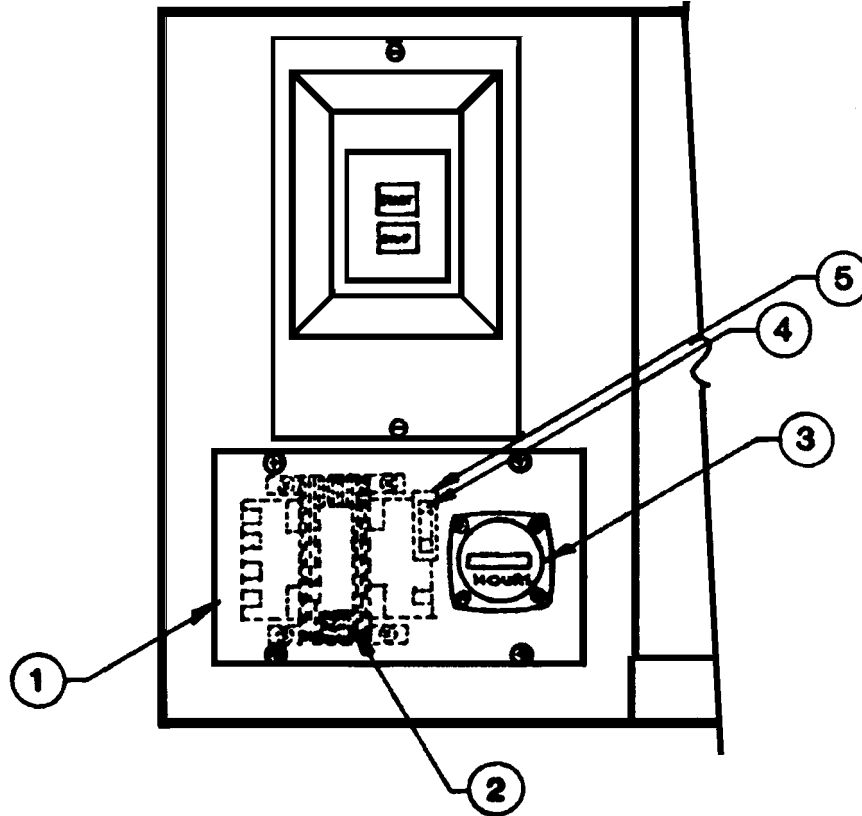

ITEM	PART NUMBER	DESCRIPTION	QTY
1	S-1072	Cover	1
2	* EC-1069	Transformer 208V/60Hz, 380V/50Hz, 575V/60Hz, 415V/50Hz	1
	* EC-1070	Transformer 230V/60Hz, 220V/50Hz, 460V/60Hz, 440V/50Hz	1
3	EC-1060	Hourmeter	1
4	EC-1161	Fuse—1-1/2 AMP, Glass Tube Slo Blo	1
5	EC-1071	Holder, Fuse	1

* Select one based on voltage.

TRONAIR

05/2002 - AA - Rev. 21

- 26 -

**Model: 05-7015 Series
Hydraulic Power Unit**

Option 16—Return Filter Assembly

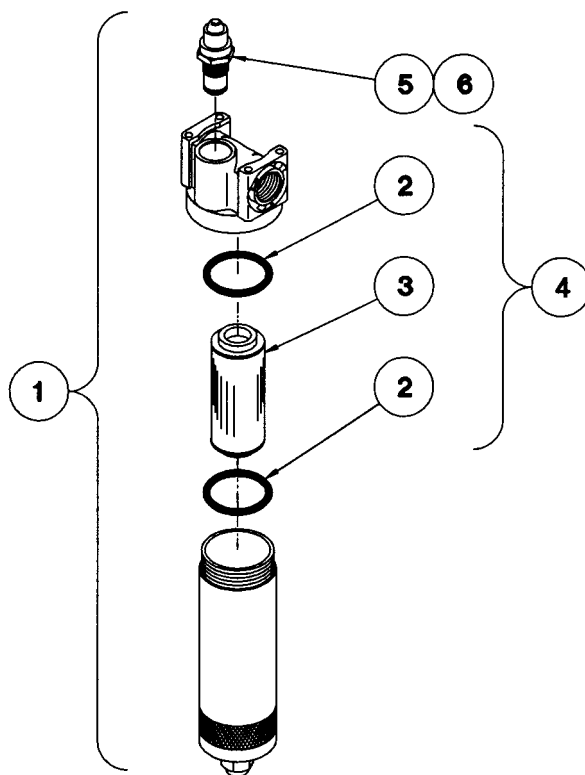

ITEM	FLUID	PART NUMBER	DESCRIPTION	QTY
1	Mineral Base Phosphate Ester	HC-1453 HC-1477	Assembly, Filter Assembly, Filter	1 1
<u>FILTER REPLACEMENT PARTS</u>				
2	Mineral Base Phosphate Ester	HC-2000-142 HC-2006-142	O-ring O-ring	2 2
3	Mineral Base Phosphate Ester	HC-1454 HC-1476	Element, Filter Element, Filter	1 1
4	Mineral Base Phosphate Ester	K-3096 K-3097	Kit, Filter Element Kit, Filter Element	1 1
5	Mineral Base Phosphate Ester	HC-1849 HC-1851	Indicator, Clogging Indicator, Clogging	1 1
6	Mineral Base Phosphate Ester	K-1509 K-1510	Kit, O-ring Kit, O-ring	1 1

NOTE: Item 3 is included with Item 4.



Model: 05-7015 Series
Hydraulic Power Unit

Option 24—Reservoir Return Hose
(Mineral Base Fluid Only)

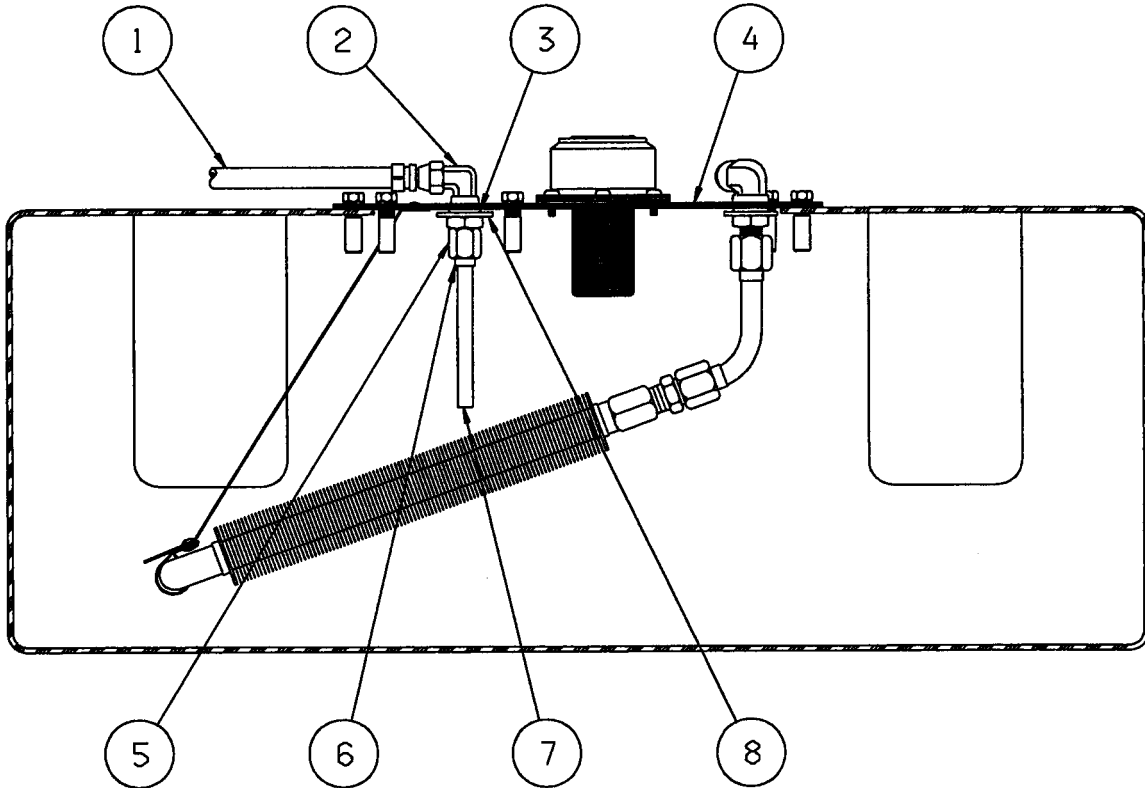

ITEM	PART NUMBER	DESCRIPTION	QTY
1	Z-2336	Hose, Reservoir Return	1
2	N-2022-05-S	Elbow, Bulkhead Union	1
3	HC-2010-906	O-ring	1
4	J-2723	Lid, Reservoir	1
5	N-2000-05-S	Nut, 37° Flare	1
6	N-2019-05-S	Sleeve	1
7	TR375-05*004.00	Tube	1
8	G-1250-1090W	Flatwasher, 1/2" Narrow	1

TRONAIR

05/2002 - AA - Rev. 21

- 28 -



APPENDIX I

Instrument
Certification
Notice



APPENDIX II

Lincoln
Motor
Manual



APPENDIX III

Oilgear
Manual



APPENDIX IV

MSDS
Hydraulic
Fluid