

# **TRONAIR**

## **OPERATION & SERVICE MANUAL**

**Model: 05-7022-XXXX**

### **HYDRAULIC POWER UNIT**

March 1998

Rev: 20



---

### ***Tronair***

*South 1740 Eber Road  
Holland, Ohio 43528-9794*

*Phone: (419) 866-6301 • 800-426-6301*

*Fax: (419) 867-0634*

*Web Site: [www.tronair.com](http://www.tronair.com) E-mail Address: [mail@tronair.com](mailto:mail@tronair.com)*



# TRONAIR

05-7022-XXXX

## HYDRAULIC POWER UNIT

### TABLE OF CONTENTS

	<u>PAGE</u>
Front Panel Controls .....	1
Internal Components .....	2
Electrical Schematic .....	3
Hydraulic Schematic .....	4
1.0 General Description .....	5
2.0 Technical Specifications .....	5
3.0 Preparation For Use .....	6
3.1 Servicing Reservoir .....	6
3.2 Connecting Electrical Leads .....	6
4.0 Operation .....	7
4.1 General Comments .....	7
A. Training .....	7
B. Use Of The HPU Reservoir .....	7
4.2 Preliminary Adjustments And Operation .....	8
A. Flow Control Adjustment .....	8
B. Pressure Control Adjustment .....	8
C. Reservoir Selector Valve Operation .....	8
1. Aircraft Reservoir Position (Closed Loop) .....	9
2. HPU Reservoir Position (Open Loop) .....	9
D. Bypass Valve Operation .....	10
1. Start Up Operation .....	10
2. Shut Down Operation .....	10
4.3 Sample Valve .....	10
4.4 Bleeding Air From System .....	11
4.5 Abbreviated Operating Instructions .....	11
4.6 Options .....	12
A. Pyrometer .....	12
B. Dual System Operation .....	12-13
C. Hourmeter .....	13
D. Hand Service Pump .....	13
E. Return Filter .....	13
5.0 Maintenance .....	14
5.1 General Maintenance .....	14
5.2 Filter Maintenance .....	14
5.3 Lubrication .....	14
5.4 Storage .....	14
6.0 Trouble Shooting .....	15
6.1 No Flow Or Pressure .....	15
6.2 Fluctuating Pressure Or Flow .....	15
6.3 Unit Overheats .....	15
Parts List & Illustrations .....	16-36



## HYDRAULIC POWER UNIT

### Front Panel Controls

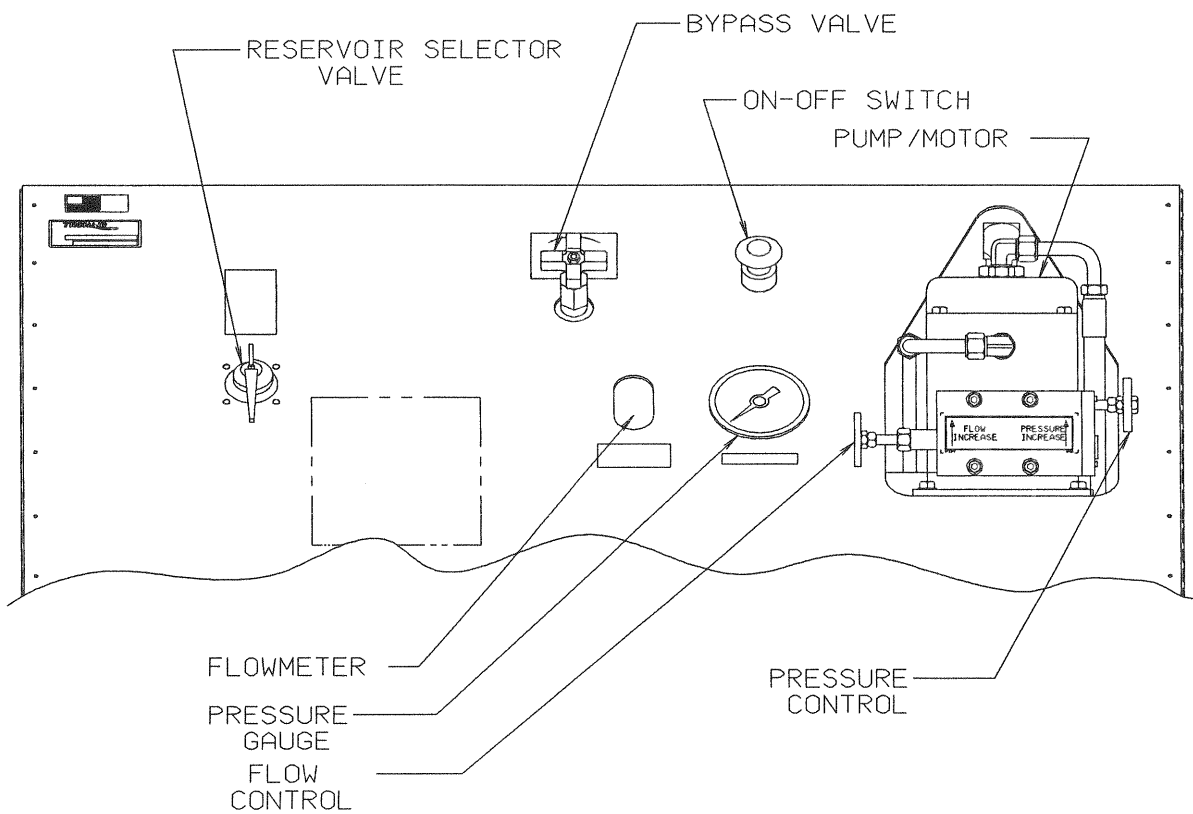

# TRONAIR

05-7022-XXXX

## HYDRAULIC POWER UNIT

### Internal Components

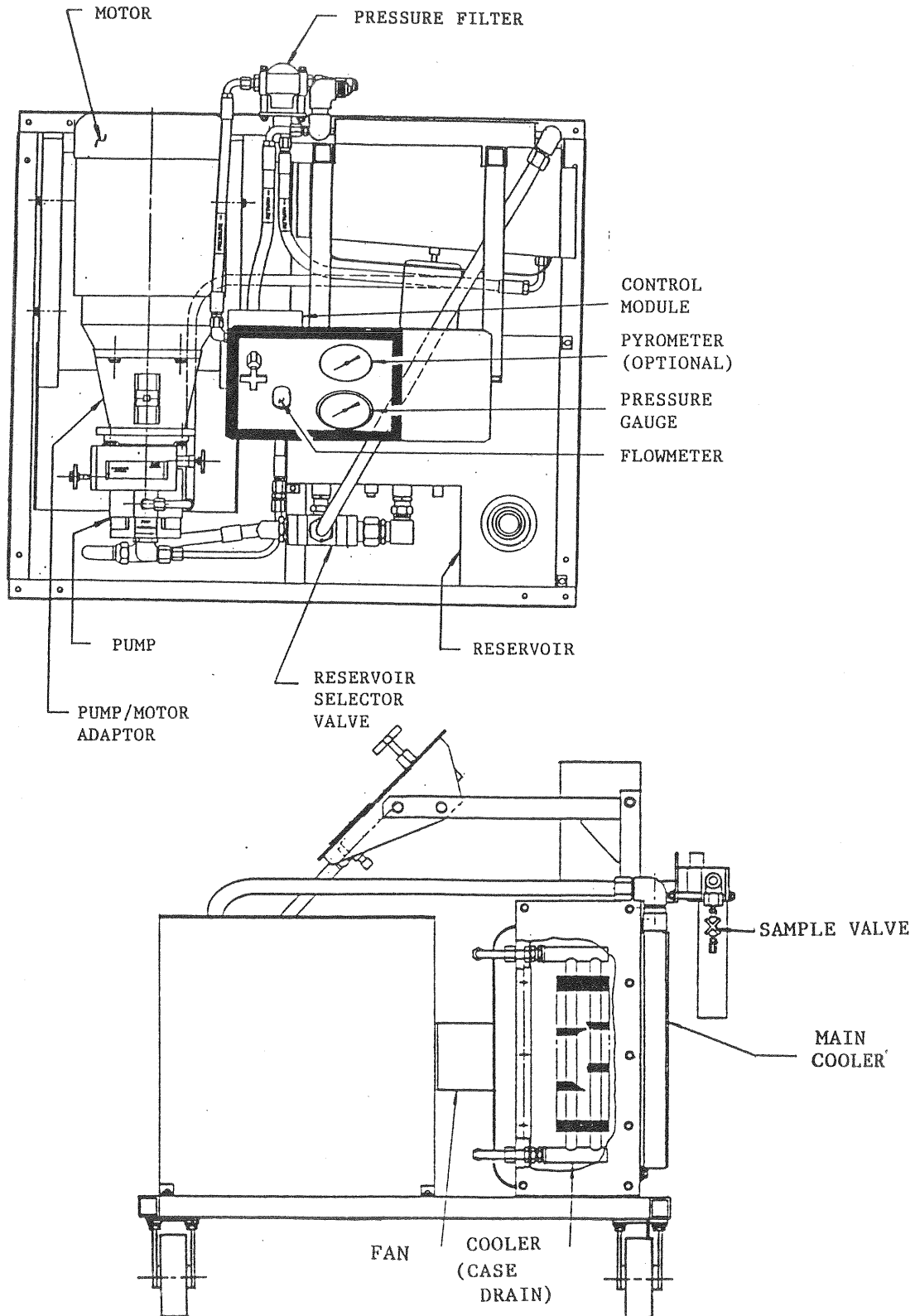

05-7022-XXXX

## HYDRAULIC POWER UNIT

### Electrical Schematic

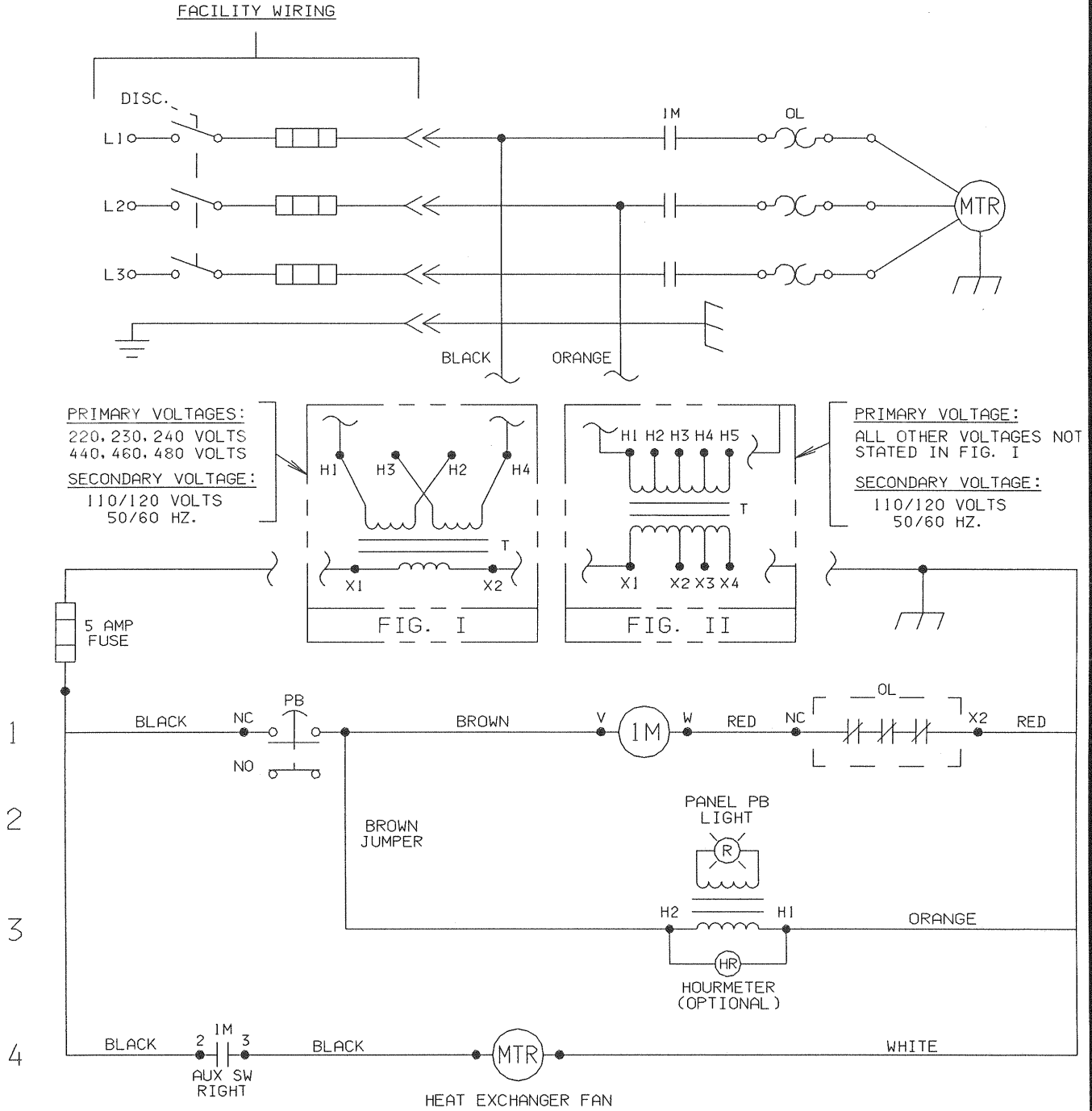

# TRONAIR

05-7022-XXXX

## HYDRAULIC POWER UNIT

### Hydraulic Schematic

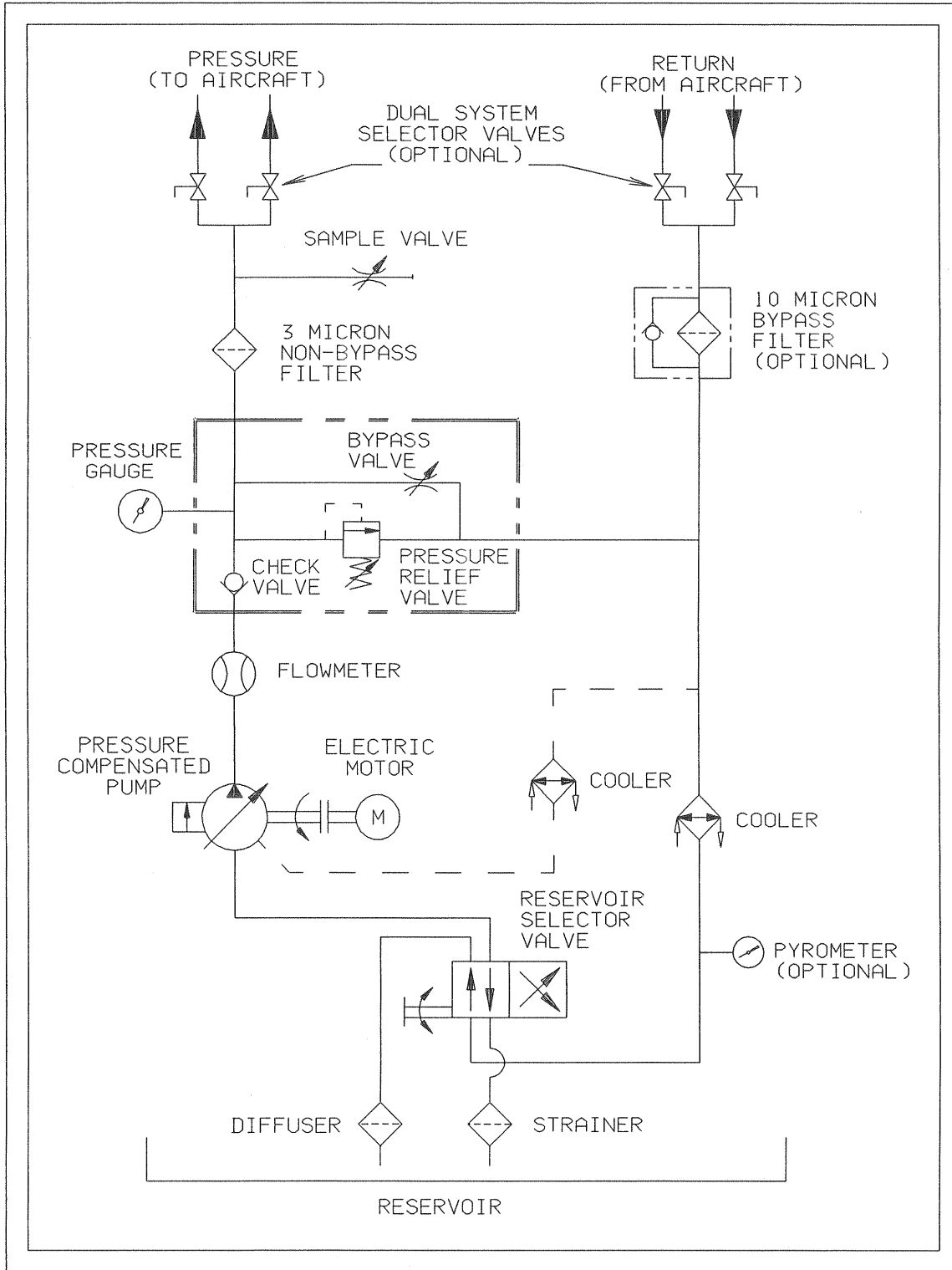



# TRONAIR

05-7022-XXXX

## HYDRAULIC POWER UNIT

### 1.0 GENERAL DESCRIPTION

The Tronair Hydraulic Power Unit (HPU) provides a source of clean, pressurized hydraulic fluid for performing required aircraft maintenance.

Some important features are:

- Pressure compensated pump with integral pressure and flow controls
- Stainless steel reservoir
- Bypass valve
- Case drain cooler
- Manual starter with overload protection
- Non-bypass pressure filter with 3 micron filter element

### 2.0 TECHNICAL SPECIFICATIONS

#### HYDRAULIC

Fluids: 05-7022-1100: MIL-H-5606  
05-7022-1200: MIL-H-83282  
05-7022-3300: Hyjet IV  
05-7022-3400: Skydrol 500

Pressure Range: 250 - 3500 PSI

Flow Range: 0 - 15 GPM

Filtration: 3 Micron Absolute

Reservoir Capacity: 25 gallons

#### ELECTRICAL

Power Requirements: 3 Phase

#### 60 HZ

55 AMPS @ 208 VAC  
50 AMPS @ 230 VAC  
30 AMPS @ 380 VAC  
25 AMPS @ 460 VAC  
20 AMPS @ 575 VAC

#### 50 HZ

55 AMPS @ 220 VAC  
27.5 AMPS @ 380, 415, 440 VAC

#### MECHANICAL

Dimensions: 45" L x 39" W x 42" H  
Weight: 740 lbs.

## HYDRAULIC POWER UNIT

### 3.0 PREPARATION FOR USE

The HPU is shipped completely assembled, and only the following steps are required to make the unit operational.

#### 3.1 SERVICING RESERVOIR

Fill the reservoir with the correct fluid until fluid level is above the minimum oil level mark.

#### 3.2 CONNECTING ELECTRICAL LEADS

Install plug onto the electrical cord and check for proper motor rotation by "bumping" the on-off switch. Correct motor rotation is indicated by an arrow on pump motor adapter. If rotation is not correct, change any two of the three input leads at the plug or inside the electrical component box.

### WARNING

**BALANCED THREE PHASE VOLTAGE MUST BE AVAILABLE TO PREVENT OVERHEATING AND DAMAGE TO THE MOTOR.**

**VOLTAGE UNBALANCED BETWEEN PHASES OCCURS WHEN THE VOLTAGES DIFFER FROM ONE ANOTHER. SOME REASONS FOR IMBALANCE ARE:**

- A) UNEQUAL LOADING OF EACH PHASE.**
- B) POOR CONNECTIONS IN THE SUPPLY.**
- C) SINGLE PHASE CONDITION CAUSED BY BLOWN FUSES OR BAD CONNECTIONS.**

**IF THESE CONDITIONS OCCUR IN THE INCOMING POWER SYSTEM, A PROTECTIVE DEVICE, SUCH AS A VOLTAGE MONITOR, SHOULD BE INSTALLED ON THE MACHINE TO PREVENT MOTOR DAMAGE.**

## HYDRAULIC POWER UNIT

### 4.0 OPERATION

#### GENERAL

Due to the complexity, differences, and ongoing changes in aircraft hydraulic systems, no attempt has been made to relate to any specific aircraft operation. It is suggested that this manual and the HPU be studied thoroughly in order to obtain optimum benefit of the various features. By combining an understanding of the HPU and the aircraft hydraulic system, many services not mentioned in this manual may be performed. Refer to the Hydraulic Schematic, Front Panel Controls, and various components pages for clarification while reading this manual.

#### 4.1 GENERAL COMMENTS

Most questions or problems concerning hydraulic power units are usually caused by improper training or understanding of hydraulics. The following comments are given to aid in obtaining maximum benefits from the hydraulic power unit.

##### a. TRAINING

Be sure that all personnel who will use the machine read the operating manual and receive training. We encourage customers to call Tronair to discuss any operating or testing requirements.

##### b. USE OF THE HPU RESERVOIR

It is suggested that the integral reservoir be used whenever possible. Use of this reservoir eliminates any possibility of cavitating the pump. Most complaints of pump noises are due to fluid restrictions in the aircraft systems when using the aircraft reservoir. Also, if the integral reservoir is used, the HPU will run considerably cooler. This occurs because the pump case drain oil is directed to the reservoir instead of the pump return. The only compromise in using the HPU reservoir is that the aircraft system reservoir must be serviced after testing, which is standard procedure.

## HYDRAULIC POWER UNIT

### 4.0 OPERATION, Continued.

#### 4.2 PRELIMINARY ADJUSTMENTS AND OPERATION

The following are basic to the operation of the HPU and should be thoroughly understood. The pressure and flow controls have lock nuts to prevent rotation of the control shaft during operation. These nuts should be moved away from the pump during adjustment of flow or pressure in order to eliminate binding of the control shafts.

##### a. FLOW CONTROL ADJUSTMENT

1. Open bypass valve.
2. Select "Hyd. Power Unit" position with reservoir selector valve.
3. Start the HPU.
4. Adjust flow control on pump for maximum desired flow. Observing the flowmeter, read flow (gallons per minute) directly from flowmeter scale. Be sure the control shaft lock nut is loose during adjustment. Tighten after adjustment to maintain setting.

##### b. PRESSURE CONTROL ADJUSTMENT

1. Open bypass valve.
2. Select "Hyd. Power Unit" position with reservoir selector valve.
3. Start the HPU.
4. Close bypass valve.
5. Adjust pressure control for desired pressure. Be sure the control shaft lock nut is loose during adjustment. Tighten after adjustment to maintain setting.

**Note:** Once the flow and pressure controls have been adjusted, it is not necessary to change these settings after each operation unless desired.

##### c. RESERVOIR SELECTOR VALVE OPERATION

Operation of the reservoir selector valve allows the operator to select either the aircraft reservoir (closed loop) or the HPU reservoir (open loop).

#### CAUTION

The reservoir selector valve should only be operated when the HPU is not running. The operation of the reservoir selector valve should be done prior to starting the HPU.

## HYDRAULIC POWER UNIT

### 4.2 PRELIMINARY ADJUSTMENTS AND OPERATION, Continued.

#### 1. AIRCRAFT RESERVOIR POSITION (CLOSED LOOP)

In this position, the HPU is dependent on the aircraft reservoir and system for an adequate supply of fluid. Cavitation, due to an inadequate fluid supply from the aircraft, may be indicated by erratic indication of the system pressure gage or flowmeter. Usually, the aircraft fluid supply will be restricted due to small return oil lines in the aircraft. Sometimes this problem can be minimized or eliminated by pressurizing the aircraft reservoir with air.

#### CAUTION

**If the aircraft reservoir is pressurized, do not exceed the aircraft manufacturer's recommendation.**

If the aircraft reservoir cannot be pressurized or the cavitation persists, decrease the flow control setting until the cavitation is eliminated.

#### 2. HPU RESERVOIR POSITION (OPEN LOOP)

In this position, the HPU reservoir supplies oil to the pump and accepts return oil from the aircraft. It is desirable to operate the HPU in this mode since it eliminates any possibility of cavitation.

Since the HPU reservoir is vented to atmosphere and the aircraft is at a higher level, it is *normal* for the aircraft reservoir to drain into the HPU reservoir. It is, therefore, necessary to be sure that sufficient room is available in the HPU reservoir to accommodate the additional fluid.

#### CAUTION

**The aircraft system reservoir must be serviced after completion of operational testing.**

In the "HPU Reservoir" position, faster landing gear swings are usually possible since there is no restriction to flow at the pump inlet.

On most aircraft, the aircraft reservoir may usually be serviced by disconnecting the return hose. Normally servo leakage or operation of a hydraulic component will allow some flow to the aircraft reservoir. Caution should be observed if this method is used.

# TRONAIR

05-7022-XXXX

## HYDRAULIC POWER UNIT

### WARNING

WHEN USING THE HPU RESERVOIR, IT MAY BE POSSIBLE TO OVERFILL THE AIRCRAFT RESERVOIR IF SEVERAL LANDING GEAR SWINGS ARE DONE IN A SHORT TIME PERIOD.

ALWAYS WAIT APPROXIMATELY 15 SECONDS BETWEEN GEAR SWINGS TO ALLOW THE AIRCRAFT RESERVOIR TO DRAIN INTO THE HPU. ALSO, DO NOT CHANGE THE RESERVOIR SELECTOR VALVE POSITION WHILE THE MACHINE IS RUNNING.

#### d. BYPASS VALVE OPERATION

The bypass valve is used for unloading the pump and for adjusting pump flow in conjunction with the flowmeter.

##### 1. START UP OPERATION

The bypass valve should be opened prior to starting the HPU in order to allow the motor to start under a no load condition.

##### 2. SHUT DOWN OPERATION

Prior to shutdown, the bypass valve may be opened to bleed off any residual system pressure.

### CAUTION

Excessive heat, which could damage machine components, will be generated if the bypass valve is partially open or is used for regulating flow or pressure.

- Use the flow and pressure controls for regulation.
- Use the bypass valve for unloading the system only.

#### 4.3 SAMPLE VALVE

A sample valve is provided on the rear of the unit to obtain a fluid sample for analysis or inspection. In order to obtain a representative fluid sample, it is suggested that American National Standard #B93.19-1972 be followed.

## HYDRAULIC POWER UNIT

### 4.4 BLEEDING AIR FROM SYSTEM

Rapid fluctuations of the pressure gage and flowmeter are indications of cavitation or entrapped air in the hydraulic lines and/or components. Air may enter the system when:

- Operating the unit with insufficient oil in the reservoir.
- Changing a component on the aircraft.
- Changing hose connections and/or coupling.

#### TO EASILY PURGE THE UNIT OF AIR:

- a. Fill reservoir to recommended level.
- b. Open bypass valve.
- c. Place reservoir selector valve in "Hydraulic Power Unit" position.
- d. Start unit and adjust flow control to maximum position.
- e. Run unit for 5 minutes and shut off.
- f. If additional bleeding is required, connect pressure and return hoses. Close bypass valve and repeat the procedure. Under some conditions where a large amount of air has entered the system, the pump may not be able to draw an initial prime and will not pump. If this occurs, it may be necessary to fill the pump inlet line with fluid.

### 4.5 ABBREVIATED OPERATING INSTRUCTIONS

These instructions may be used for fast reference after a thorough understanding of the HPU operation has been achieved.

#### a. INITIAL ADJUSTMENTS

1. Set flow control (see 4.2-a).
2. Set pressure control (see 4.2-b).

#### b. PRIOR TO STARTING

1. Select reservoir valve position.
2. Open bypass valve.

#### c. OPERATION

1. Start the HPU.
2. Close bypass valve.

#### d. SHUT OFF

1. Open bypass valve.
2. Stop the HPU.

## HYDRAULIC POWER UNIT

### 4.6 OPTIONS

The following options are available on some models of hydraulic power units. Refer to the appropriate option description for operation information.

#### a. PYROMETER

The pyrometer indicates fluid temperature in the return system. It is normal for this temperature to increase when the aircraft is not demanding any flow and the HPU is holding pressure.

#### **CAUTION**

**If this temperature rises to 150° F:**

- (1) Operate from the HPU reservoir or,**
- (2) Open the bypass valve, or**
- (3) Cycle the landing gear a few times or,**
- (4) Shut off the HPU.**

#### b. DUAL SYSTEM OPERATION

The dual system option allows control of fluid flow to aircraft with two hydraulic systems. The systems consist of two sets of hoses and valves located in the pressure and return systems. The valves are mounted on the rear of the hydraulic power unit and are of the 90 degree ball type. The valves are open when the operating handle is in line with the valve.

Although both systems may be operated simultaneously, usually only one system is required at any one time. If both valve sets are open simultaneously, the pump output will be divided between the two systems. Also, cross flow between aircraft reservoirs may occur if a reservoir level or pressure differential exists. *Select valve positions prior to starting machine.*

#### TO OPERATE THE DUAL SYSTEM:

1. Before starting machine, open pressure and return valves of the *same* system.

#### **WARNING**

**ASSURE PRESSURE AND RETURN HOSES OF THE SAME SYSTEM ARE PAIRED AND USED TOGETHER.**



## HYDRAULIC POWER UNIT

### 4.6 OPTIONS TO OPERATE THE DUAL SYSTEM, Continued.

2. After completing tests on one system, shut the machine off before selecting the second system.

### **WARNING**

**NEVER OPEN OR CLOSE DUAL SYSTEM VALVES WITHOUT SHUTTING OFF THE HYDRAULIC POWER UNIT. DAMAGE TO THE AIRCRAFT SYSTEM OR RESERVOIR MAY RESULT IF EITHER RETURN LINE VALVE IS CLOSED WHILE THE MACHINE IS RUNNING.**

3. If equipped with the **dual system crossover check option**, separate pressure gauges are located after each system pressure shut off valve. This allows bleed down pressures to be read when the pressure valves are closed. Follow aircraft manufacturer's instructions.

#### c. HOURMETER

The hourmeter records operating hours of the HPU. The main use of the hourmeter is to schedule filter changes.

#### d. HAND SERVICE PUMP

This pump is used primarily for filling aircraft reservoirs after testing, bleeding brakes, etc.

#### e. RETURN FILTER

The return oil filter has a 10 micron replaceable element that is not cleanable. It is recommended that this filter element be changed whenever the visual pop-up indicator button "pops up" or after every 25 hours of operation, annually, or whenever a reduced maximum flow is noticed. Push down visual indicator button if needed when replacing filter element. Refer to the parts list for the correct filter element number.

## HYDRAULIC POWER UNIT

### 5.0 MAINTENANCE

#### 5.1 GENERAL MAINTENANCE

The hydraulic power unit should be maintained in a safe and clean condition at all times.

- Locate and correct the source of any and all leaks.
- Inspect hoses and electrical cords periodically for damage and wear. Replace as required.

#### 5.2 FILTER MAINTENANCE

The main pressure filter has a replaceable element that is **not** cleanable. It is recommended that this filter element be changed whenever the visual pop-up indicator button "pops up" or after every *25 hours* of operation, *annually*, or whenever a *reduced maximum flow* is noticed. Push down visual indicator button if needed when replacing filter element. Refer to the parts list for the correct filter element number.

#### 5.3 LUBRICATION

The swivel casters are equipped with grease fittings which should be lubricated annually.

#### 5.4 STORAGE

In the event that the HPU will not be used for 12 months or longer, the reservoir may be drained. The unit should then be appropriately covered in order to maintain cleanliness.

## HYDRAULIC POWER UNIT

### 6.0 TROUBLE SHOOTING

#### 6.1 NO FLOW OR PRESSURE

- a. Flow control set too low  
- Increase flow setting.
- b. Motor running in wrong direction  
- See Section 3.0, "Preparation for Use".
- c. Insufficient oil in reservoir  
- See Section 3.0, "Preparation for Use"
- d. Air in hydraulic lines  
- See Section 4.4, "Bleeding Air From System".
- e. Faulty pump  
- Repair or replace pump.

#### 6.2 FLUCTUATING PRESSURE OR FLOW

- a. Pump cavitation  
- See Section 4.2.c.1, "Aircraft Reservoir Position.
- b. Air in hydraulic lines  
- See Section 4.4, "Bleeding Air From System".

#### 6.3 UNIT OVERHEATS

- a. Low fluid level in reservoir  
- See Section 3.0. "Preparation for Use".
- b. Running unit for long time periods without operating aircraft components  
- Cycle landing gear or other components periodically or allow unit to cool.
- c. Bypass valve partially open  
- See Section 4.2.d, "Bypass Valve Operation".

#### **NOTE:**

**Running time under deadhead condition can be increased substantially by selecting the "Hyd. Power Unit" position; reservoir selector valve.**

**When a pressure compensated pump is required to hold pressure without any flow delivery (deadhead condition) it is normal for the pump case drain flow and temperature to increase. By selecting the "Hyd Power Unit" position of the selector valve, all of the oil in the reservoir is utilized for cooling.**

# TRONAIR

## 05-7022-XXXX HYDRAULIC POWER UNIT

### PARTS LIST

<u>PAGE NO.</u>	<u>DESCRIPTION</u>
17	External Components
18	Internal Components
19	Electrical Components
20	Reservoir Selector Valve
21	Reservoir Assembly
22	Pump/Motor Assembly
23	Pressure Filter Assembly
24	Control Module
25	Bypass Valve
26	Pressure Relief Valve
27	Check Valve
28	Option 06 - Dual System
29	Option 09 - Hand Service Pump
30	Option 09 - Hand Service Pump Filter Assembly
31	Option 14 - Crossover Check Valve System
32	Option 16 - Return Filter
33	Option 16 - Return Filter Assembly
34	Option 29 - Reservoir Fill Hand Pump
35-36	Z-2947 (MB)/Z-2885 (PE) Hand Pump Assembly

# TRONAIR

05-7022-XXXX

## HYDRAULIC POWER UNIT

### External Components

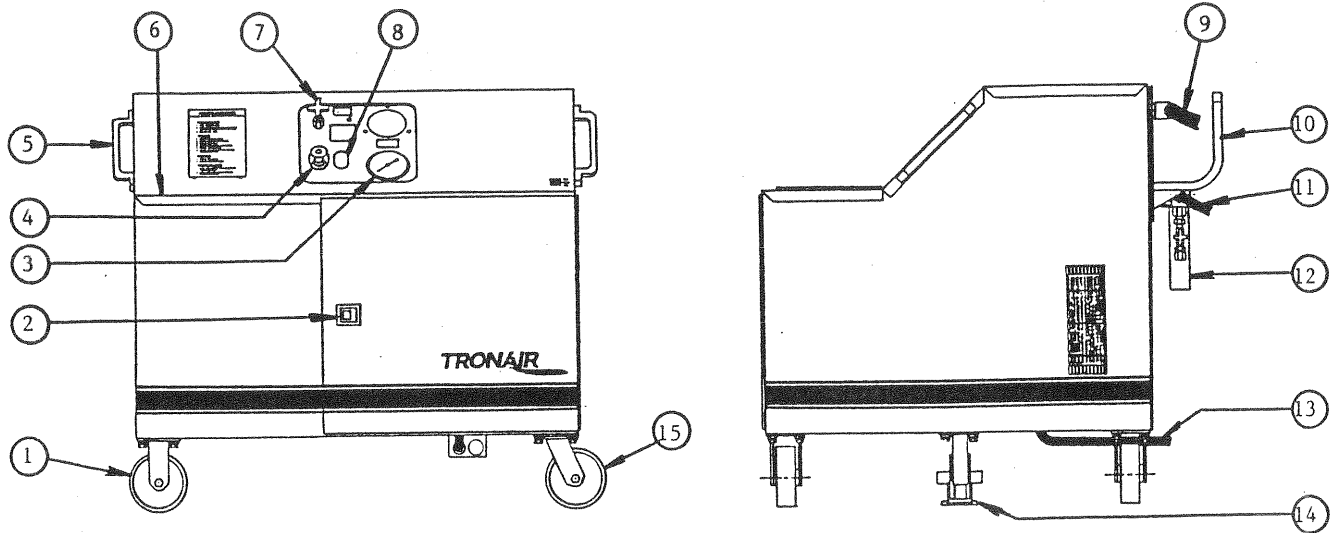

<u>ITEM</u>	<u>FLUID</u>	<u>PART NUMBER</u>	<u>DESCRIPTION</u>	<u>QTY.</u>
1		U-1013	Caster (Rigid)	1
2		H-1207	Latch	1
3		HC-1399	Pressure Gauge	1
4		EC-1058	ON-OFF Switch	1
		EC-1225	Replacement Lamp	1
5		H-1584	Handle	1
6		H-1207	Latch (Not Shown)	1
7		See Page 26.	Bypass Valve	1
8		HC-1229	Flowmeter	1
9	Mineral Base	TF-1039-02*300	Return Hose	1
	Phosphate Ester	TF-1041-01*300	Return Hose	1
10		Z-1744	Hose Hanger	2
11	Mineral Base	TF-1038-01*300	Pressure Hose	1
	Phosphate Ester	TF-1040-01*300	Pressure Hose	1
12		See Page 24.	Pressure Filter	1
13		**EC-1236	Electrical Cord	1
14		H-1175	Floor Lock	1
15		U-1014	Caster (Swivel)	2

\*\* Please specify proper voltage and Hz when ordering replacement.

# TRONAIR

05-7022-XXXX

## HYDRAULIC POWER UNIT

### Internal Components

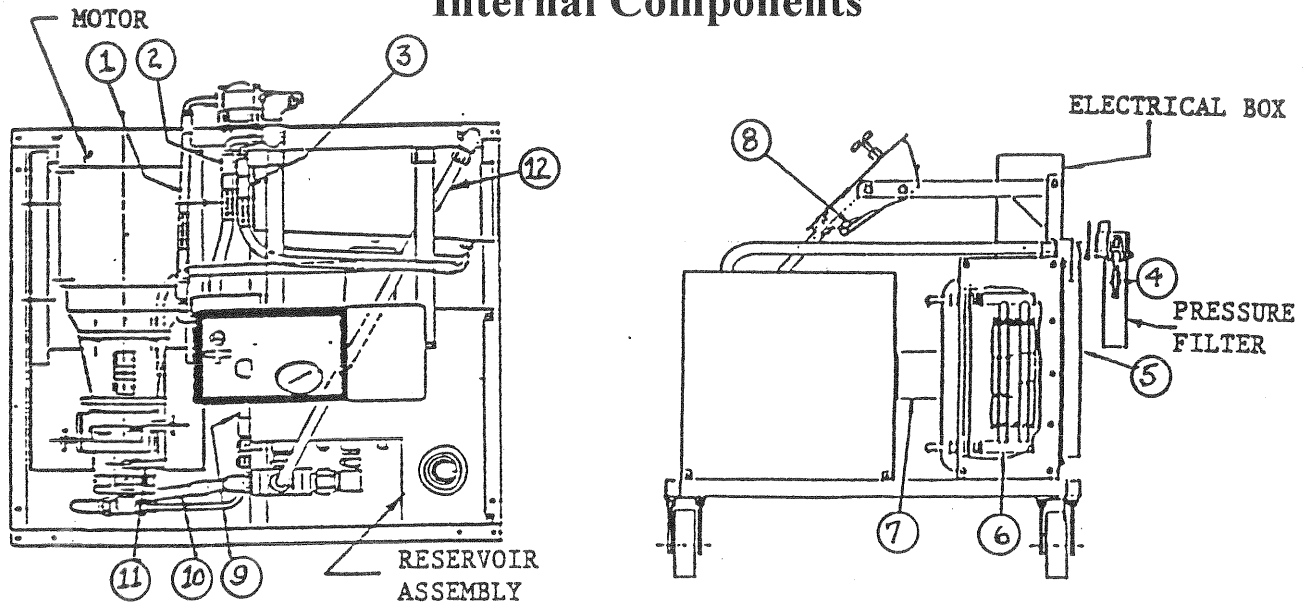

<u>ITEM</u>	<u>FLUID</u>	<u>PART NUMBER</u>	<u>DESCRIPTION</u>	<u>QTY.</u>
1	Mineral Base	TF-1037-13*22.0	Hose Assembly	1
	Phosphate Ester	TF-1041-21*22.0	Hose Assembly	1
2	Mineral Base	TF-1037-05*15.5	Hose Assembly	1
	Phosphate Ester	TF-1041-10*15.5	Hose Assembly	1
3	Mineral Base	TF-1037-13*30.8	Hose Assembly	1
	Phosphate Ester	TF-1041-21*30.8	Hose Assembly	1
4	Mineral Base	HC-1202-01	Sample Valve	1
	Phosphate Ester	HC-1202-02	Sample Valve	1
5		HC-1214	Cooler (Main)	1
6		HC-1388-01	Cooler (Case Drain)	1
7		EC-12229	Fan	1
8	Mineral Base	TF-1037-03*16.0	Hose Assembly	1
	Phosphate Ester	TF-1041-05*16.0	Hose Assembly	1
9	Mineral Base	TF-1038-08*33.3	Hose Assembly	1
	Phosphate Ester	TF-1041-09*33.3	Hose Assembly	1
10	Mineral Base	TF-1039-07*19.0	Hose Assembly	1
	Phosphate Ester	TF-1041-13*19.0	Hose Assembly	1
11	Mineral Base	TF-1037-14*62.0	Hose Assembly	1
	Phosphate Ester	TF-1041-41*62.0	Hose Assembly	1
12		Z-2405	Tube Assembly	1

# TRONAIR

05-7022-XXXX

## HYDRAULIC POWER UNIT

### Electrical Components

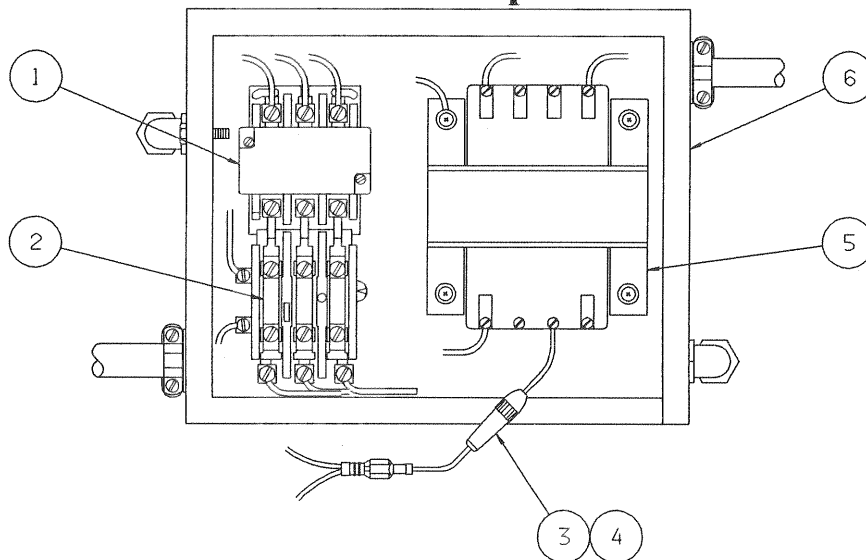

<u>ITEM</u>	<u>PART NUMBER</u>	<u>DESCRIPTION</u>	<u>QTY.</u>
1	See Table Below	Starter	1
2	See Table Below	Heater	3
3	EC-1328	Fuse Heater	1
4	EC-1210-08	Fuse	1
5	See Table Below	Transformer	1
6	EC-1310	Electrical Box	1

TABLE (Specify proper voltage and HZ when ordering)

<u>VOLTAGE</u>	<u>HEATER</u>	<u>STARTER</u>	<u>TRANSFORMER</u>
208V/60HZ	EC-1207-E78	EC-1214-04-F	EC-1075
230V/60HZ	EC-1207-E78	EC-1205-04-F	EC-1074
380V/60HZ	EC-1207-E72	EC-1204-04-F	EC-1075
460V/60HZ	EC-1207-E69	EC-1203-04-F	EC-1074
575V/60HZ	EC-1207-E65	EC-1203-04-F	EC-1075
200V/50HZ	EC-1207-E78	EC-1205-04-F	EC-1075
220V/50HZ	EC-1207-E78	EC-1205-04-F	EC-1074
380V/50HZ	EC-1207-E69	EC-1203-04-F	EC-1075
415V/50HZ	EC-1207-E69	EC-1203-04-F	EC-1075
440V/50HZ	EC-1207-E69	EC-1203-04-F	EC-1074

## HYDRAULIC POWER UNIT

### Reservoir Selector Valve

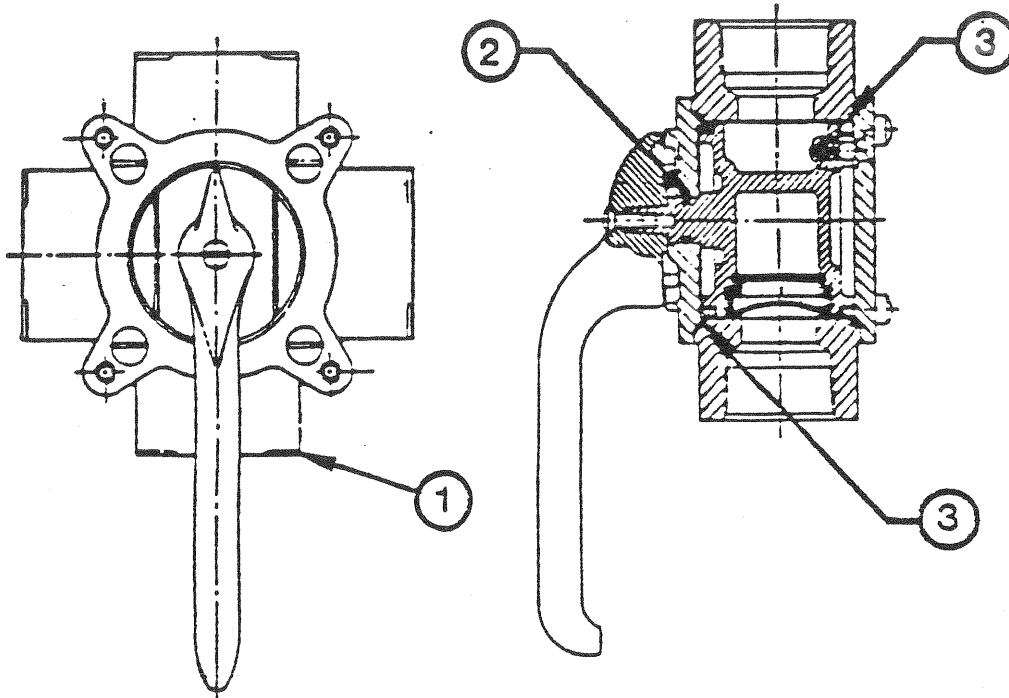

<u>ITEM</u>	<u>FLUID</u>	<u>PART NUMBER</u>	<u>DESCRIPTION</u>	<u>QTY.</u>
1	Mineral Base	HC-1032	Valve Assembly	1
	Phosphate Ester	Z-1127	Valve Assembly	1
2	Mineral Base	HC-2000-016	O-ring	1
	Phosphate Ester	HC-2006-016	O-ring	1
3	Mineral Base	HC-2000-149	O-ring	1
	Phosphate Ester	HC-2006-149	O-ring	1
4	Mineral Base	K-1496	*Seal Kit	1
	Phosphate Ester	K-1497	*Seal Kit	1

\* Seal Kits include Items 2 & 3.

**Note:** For replacement of parts other than what is listed—a complete valve (Item 1) must be purchased.



# TRONAIR

05-7022-XXXX

## HYDRAULIC POWER UNIT

### Reservoir Assembly

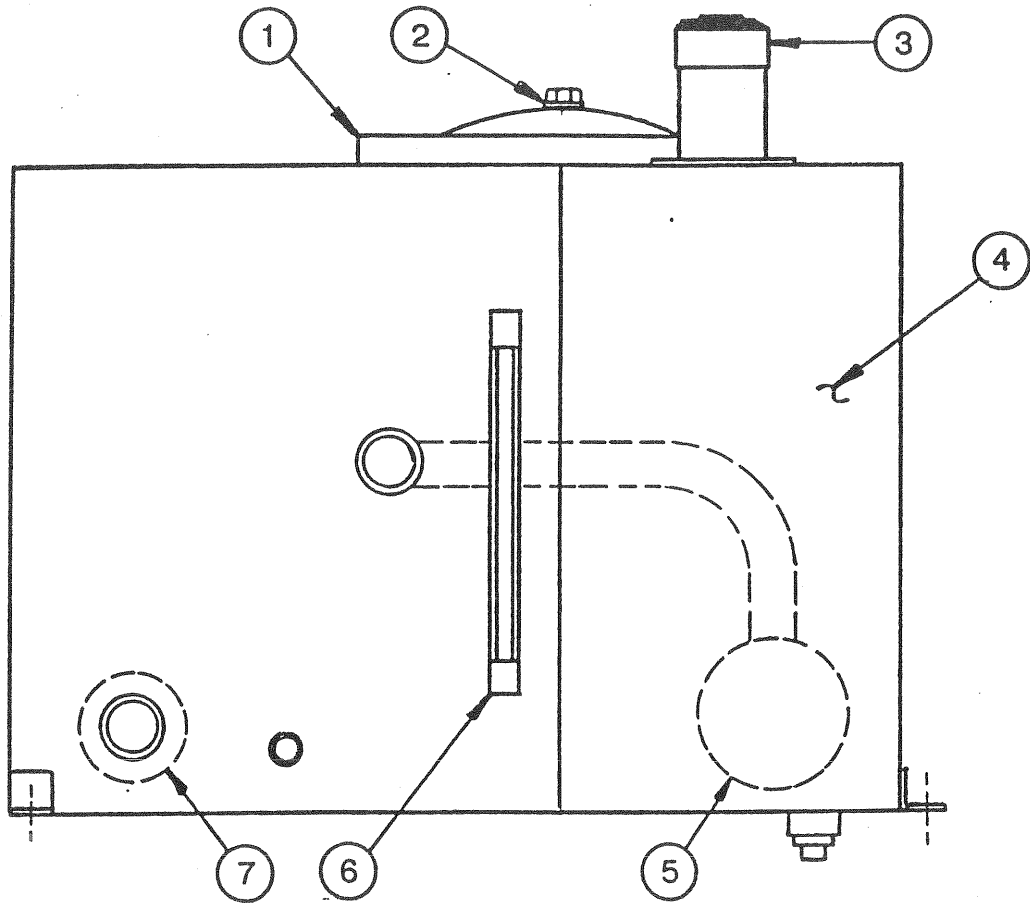

<u>ITEM</u>	<u>FLUID</u>	<u>PART NUMBER</u>	<u>DESCRIPTION</u>	<u>QTY.</u>
1	Mineral Base	H-1733-01	Gasket, Cover	1
	Phosphate Ester	H-1733-02	Gasket, Cover	1
2		H-1735-02	Washer, Nylon	1
3		HC-1401-06	Filler, Breather	1
4		Z-2393	Reservoir	1
5		HC-1029	Diffuser	1
6	Mineral Base	HC-1382-14	Sight Gauge	1
	Phosphate Ester	HC-1383-14	Sight Gauge	1
7		HC-1107	Strainer	1

# TRONAIR

05-7022-XXXX

## HYDRAULIC POWER UNIT

### Pump/Motor Assembly

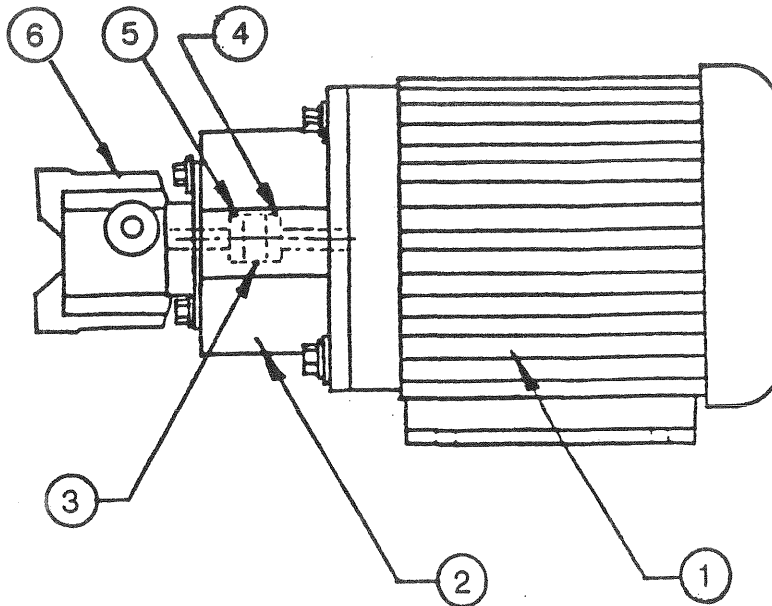

<u>ITEM</u>	<u>FLUID</u>	<u>PART NUMBER</u>	<u>DESCRIPTION</u>	<u>QTY.</u>
1		See Table A	Motor	1
2		HC-1393-14	Pump/Motor Assembly	1
3		H-1298	Spider	1
4		H-1299-06	Coupling Body/Motor	1
5		H-1299-09	Coupling Body/Pump	1
6	Mineral Base	K-1649	Hydraulic Pump	1
	Phosphate Ester	K-1648	Hydraulic Pump	1

#### PUMP REPLACEMENT PARTS

	K-1759	Shaft Seal	1
Mineral Base	*K-1996	Gaskets & O-rings Kit	1
Phosphate Ester	*K-1997	Gaskets & O-rings Kit	1

\* See pump manufacturer's service booklet for servicing of Item 6 and additional repair kits.

**Note: All Bolts are Grade 5.**

<u>TABLE A—MOTORS</u>	
<u>PART NUMBER</u>	<u>VOLTAGE</u>
EC-1186-13	208V/60Hz
EC-1186-14	230, 460V/60Hz 200, 220, 380, 415, 440V/50Hz
EC-1186-15	575V/60Hz

## HYDRAULIC POWER UNIT

### Pressure Filter Assembly

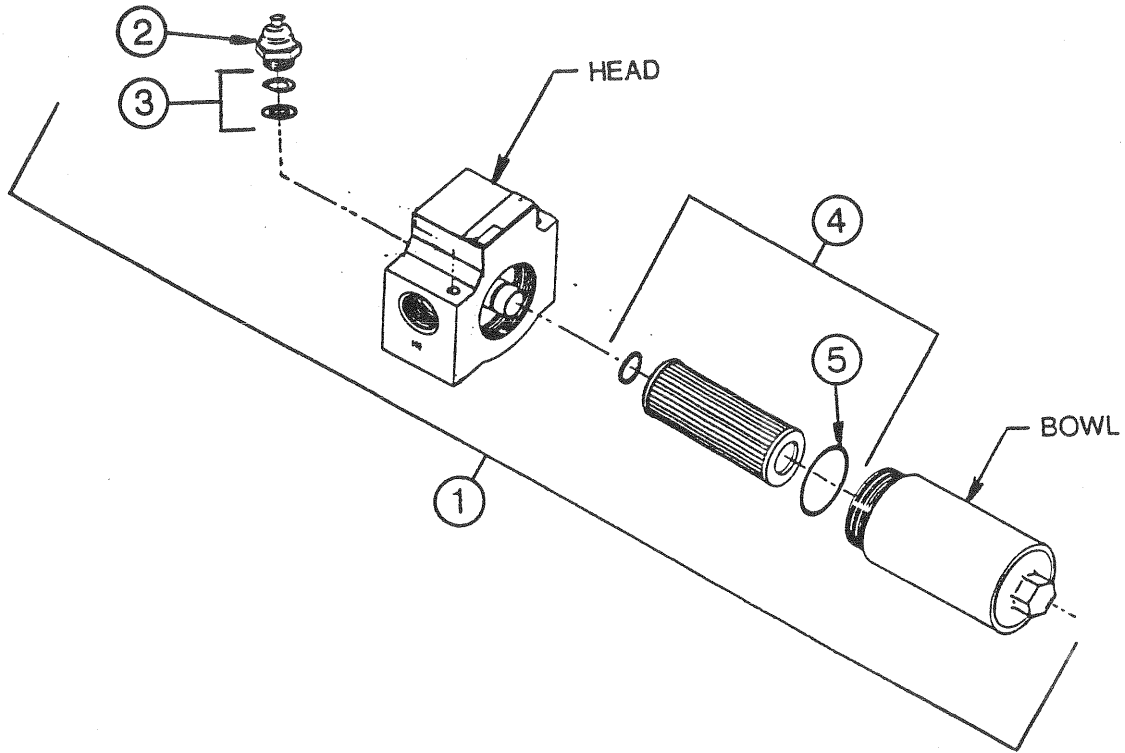

<u>ITEM</u>	<u>FLUID</u>	<u>PART NUMBER</u>	<u>DESCRIPTION</u>	<u>QTY.</u>
1	Mineral Base	HC-1440	Filter Assembly	1
	Phosphate Ester	HC-1441	Filter Assembly	1
2	Mineral Base	HC-1412	Clogging Indicator	1
	Phosphate Ester	HC-1413	Clogging Indicator	1

#### CLOGGING INDICATOR REPLACEMENT PARTS

3	Mineral Base	K-1509	O-ring Kit	1
	Phosphate Ester	K-1510	O-ring Kit	1

#### FILTER REPLACEMENT PARTS

4	Mineral Base	K-1416	Filter Element Kit	1
	Phosphate Ester	K-1417	Filter Element Kit	1
5	Mineral Base	HC-2000-138	Bowl O-ring	1
	Phosphate Ester	HC-2006-138	Bowl O-ring	1

\* Note: Item 5 is included in Item 4.

# TRONAIR

05-7022-XXXX

## HYDRAULIC POWER UNIT

### Control Module

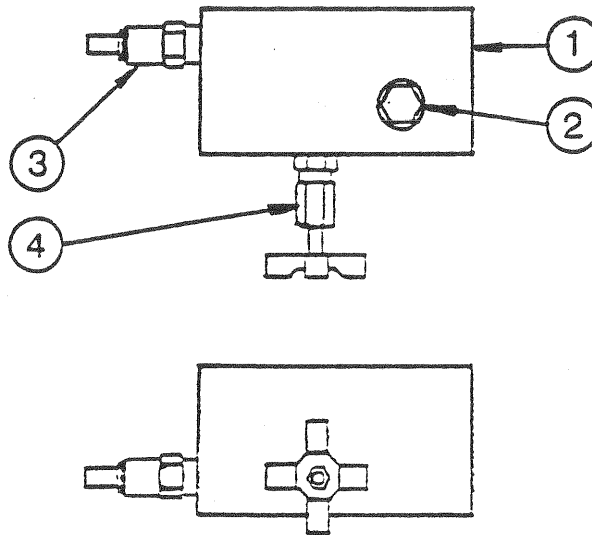

<u>ITEM</u>	<u>FLUID</u>	<u>PART NUMBER</u>	<u>DESCRIPTION</u>	<u>QTY.</u>
1		J-1476	Valve Body	1
2	Mineral Base	HC-1262	Check Valve	1
	Phosphate Ester	Z-1712	Check Valve	1
3	Mineral Base	HC-1451	Pressure Relief Valve	1
	Phosphate Ester	HC-1452	Pressure Relief Valve	1
4	Mineral Base	HC-1254	Bypass Valve	1
	Phosphate Ester	Z-1711	Bypass Valve	1

05-7022-XXXX  
HYDRAULIC POWER UNIT

## Bypass Valve

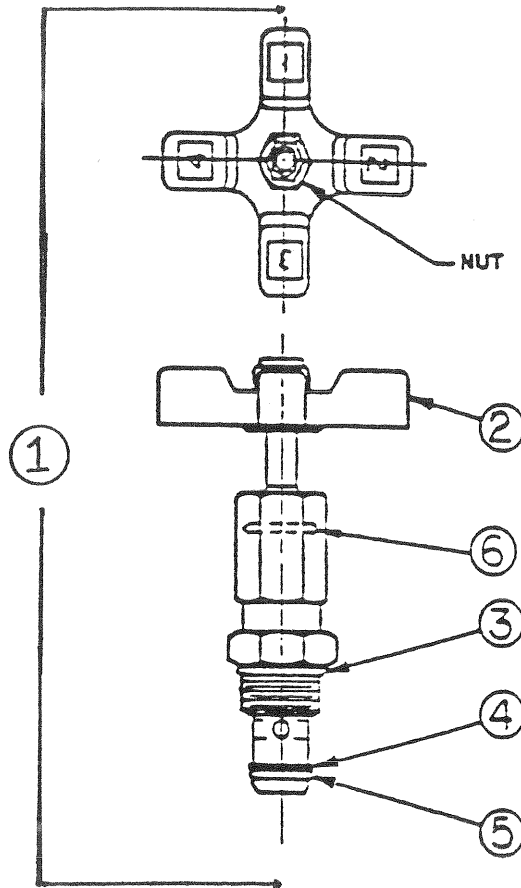

<u>ITEM</u>	<u>FLUID</u>	<u>PART NUMBER</u>	<u>DESCRIPTION</u>	<u>QTY.</u>
1	Mineral Base	HC-1254	Bypass Valve Assembly	1
	Phosphate Ester	Z-1711	Bypass Valve Assembly	1
2		HC-1130	Valve Handle	1
3	Mineral Base	HC-2010-910	O-ring	1
	Phosphate Ester	HC-2013-910	O-ring	1
4		HC-2020-014	Back-up Ring	1
5	Mineral Base	HC-2000-014	O-ring	1
	Phosphate Ester	HC-2006-014	O-ring	1
6	Mineral Base	HC-2000-012	O-ring	1
	Phosphate Ester	HC-2006-012	O-ring	1

## HYDRAULIC POWER UNIT

### Pressure Relief Valve

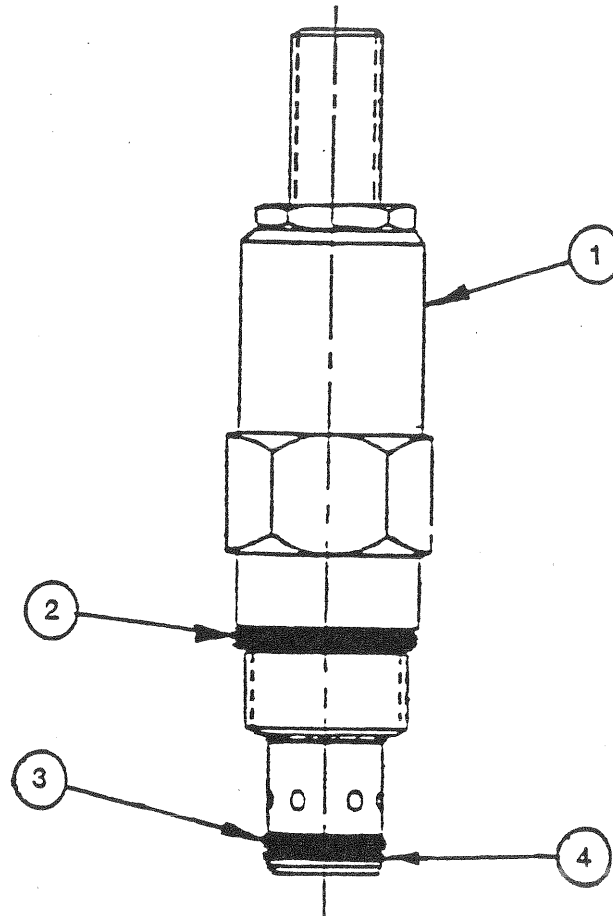

<u>ITEM</u>	<u>FLUID</u>	<u>PART NUMBER</u>	<u>DESCRIPTION</u>	<u>QTY.</u>
1	Mineral Base	HC-1451	Pressure Relief Valve	1
	Phosphate Ester	HC-1452	Pressure Relief Valve	1
2	Mineral Base	HC-2010-910	O-ring	1
	Phosphate Ester	HC-2013-910	O-ring	1
3	Mineral Base	HC-2000-014	O-ring	1
	Phosphate Ester	HC-2006-014	O-ring	1
4		HC-2020-010	Back-up Ring	1

## HYDRAULIC POWER UNIT

### Check Valve

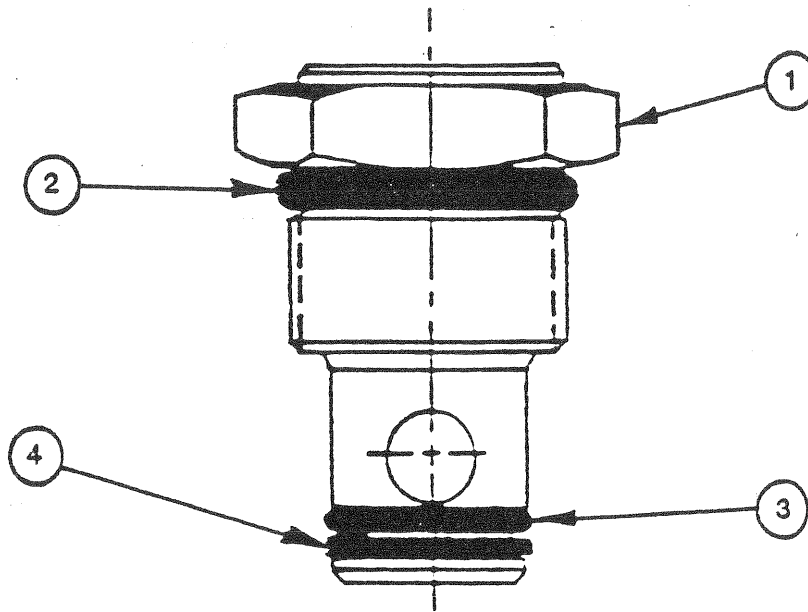

<u>ITEM</u>	<u>FLUID</u>	<u>PART NUMBER</u>	<u>DESCRIPTION</u>	<u>QTY.</u>
1	Mineral Base	HC-1262	Check Valve	1
	Phosphate Ester	Z-1712	Check Valve	1
2	Mineral Base	HC-2010-910	O-ring	1
	Phosphate Ester	HC-2013-910	O-ring	1
3	Mineral Base	HC-2000-014	O-ring	1
	Phosphate Ester	HC-2006-014	O-ring	1
4		HC-2020-010	Back-up Ring	1

# TRONAIR

05-7022-XXXX

## HYDRAULIC POWER UNIT

### OPTION 6 - DUAL SYSTEM

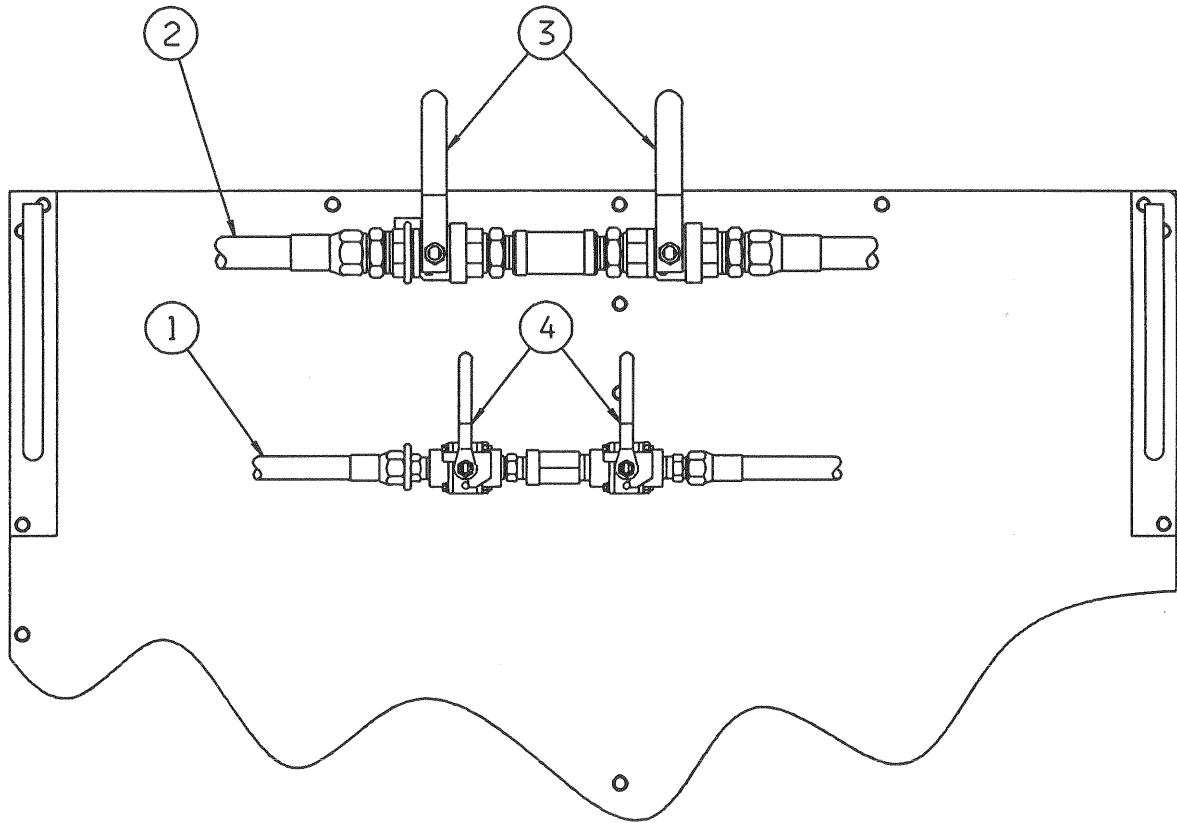

<u>ITEM</u>	<u>FLUID</u>	<u>PART NUMBER</u>	<u>DESCRIPTION</u>	<u>QTY.</u>
1	Mineral Base	TF-1038-01*300	Pressure Hose Assembly	2
	Phosphate Ester	TF-1040-01*300	Pressure Hose Assembly	2
2	Mineral Base	TF-1039-02*300	Return Hose Assembly	2
	Phosphate Ester	TF-1041-01*300	Return Hose Assembly	2
3		HC-1111	Return Ball Valve	2
4		HC-1139	Pressure Ball Valve	2
		HC-1654-04	Pressure Ball Valve	2



## Option 9—Hand Service Pump

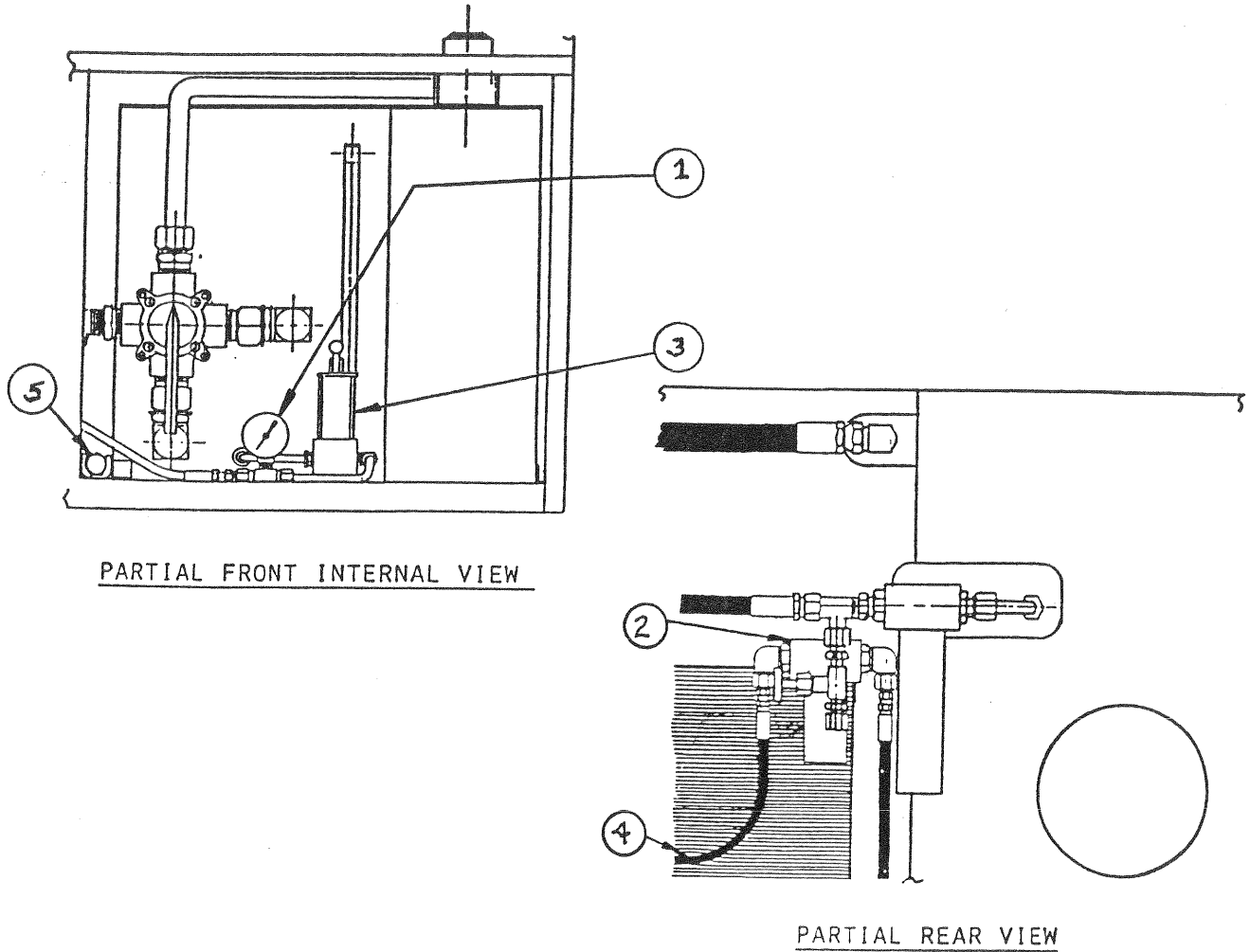

PARTIAL FRONT INTERNAL VIEW

PARTIAL REAR VIEW

<u>ITEM</u>	<u>FLUID</u>	<u>PART NUMBER</u>	<u>DESCRIPTION</u>	<u>QTY.</u>
1		HC-1042	Pressure Gauge	1
2	Mineral Base	HC-1083	Filter Assembly	1
	Phosphate Ester	HC-1084	Filter Assembly	1
3	Mineral Base	HC-1034	Hand Pump	1
	Phosphate Ester	HC-1035	Hand Pump	1
4	Mineral Base	TF-1043-01*180	Hand Pump Hose	1
	Phosphate Ester	TF-1041-05*180	Hand Pump Hose	1
5		H-1009-02	Pump Handle	1

## Option 9—Hand Service Pump Filter Assembly

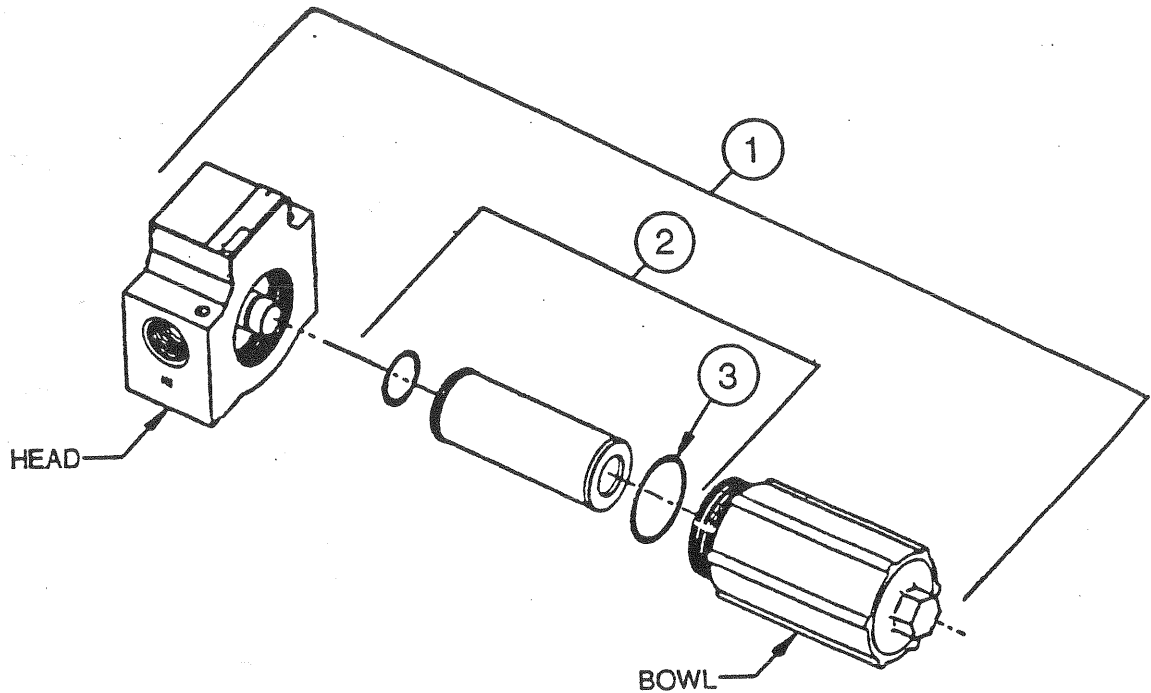

<u>ITEM</u>	<u>FLUID</u>	<u>PART NUMBER</u>	<u>DESCRIPTION</u>	<u>QTY.</u>
1	Mineral Base	HC-1083	Filter Assembly	1
	Phosphate Ester	HC-1084	Filter Assembly	1

### FILTER REPLACEMENT PARTS

2	Mineral Base	K-1414	Filter Element Kit	1
	Phosphate Ester	K-1415	Filter Element Kit	1

Item 3 is included with Item 2.

3	Mineral Base	HC-2000-138	Bowl O-ring	1
	Phosphate Ester	HC-2006-138	Bowl O-ring	1

## HYDRAULIC POWER UNIT

### Option 14—Crossover Check Valve System

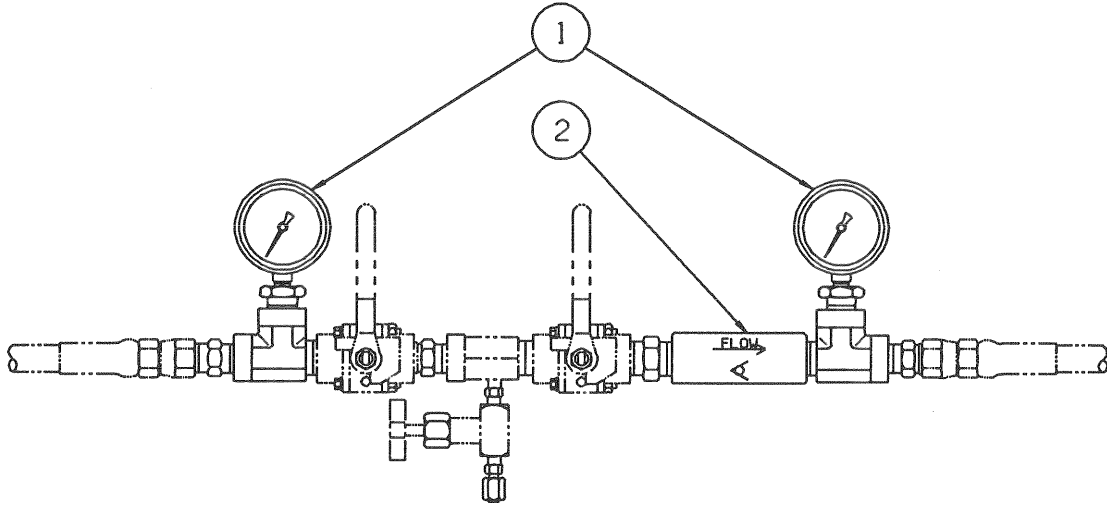

---

<u>ITEM</u>	<u>PART NUMBER</u>	<u>DESCRIPTION</u>	<u>QTY.</u>
1	HC-1042	Pressure Gauge	1
2	HC-1059	Check Valve	1

# TRONAIR

05-7022-XXXX

## HYDRAULIC POWER UNIT

### Option 16—Return Filter

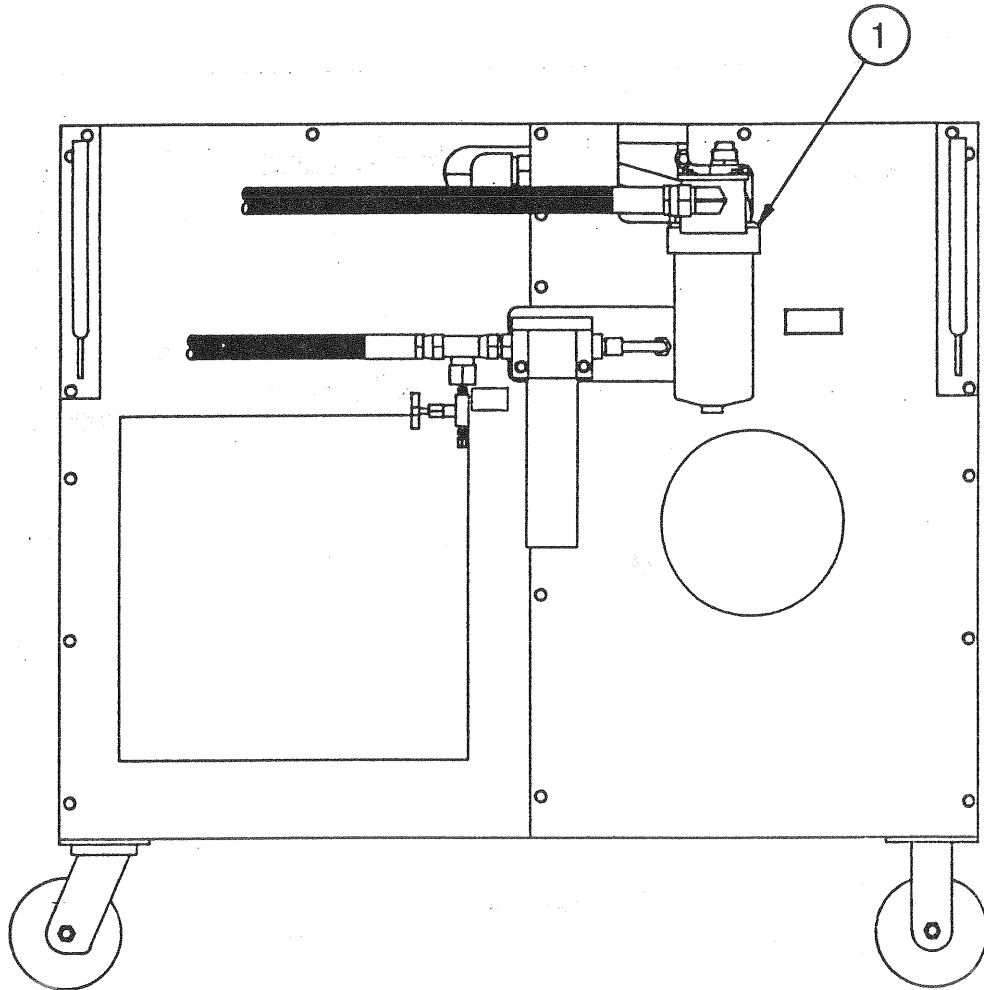

---

<u>ITEM</u>	<u>FLUID</u>	<u>PART NUMBER</u>	<u>DESCRIPTION</u>	<u>QTY.</u>
1	Mineral Base	HC-1478	Filter Assembly	1
	Phosphate Ester	HC-1505	Filter Assembly	1

# TRONAIR

05-7022-XXXX

## HYDRAULIC POWER UNIT

### Option 16—Return Filter Assembly

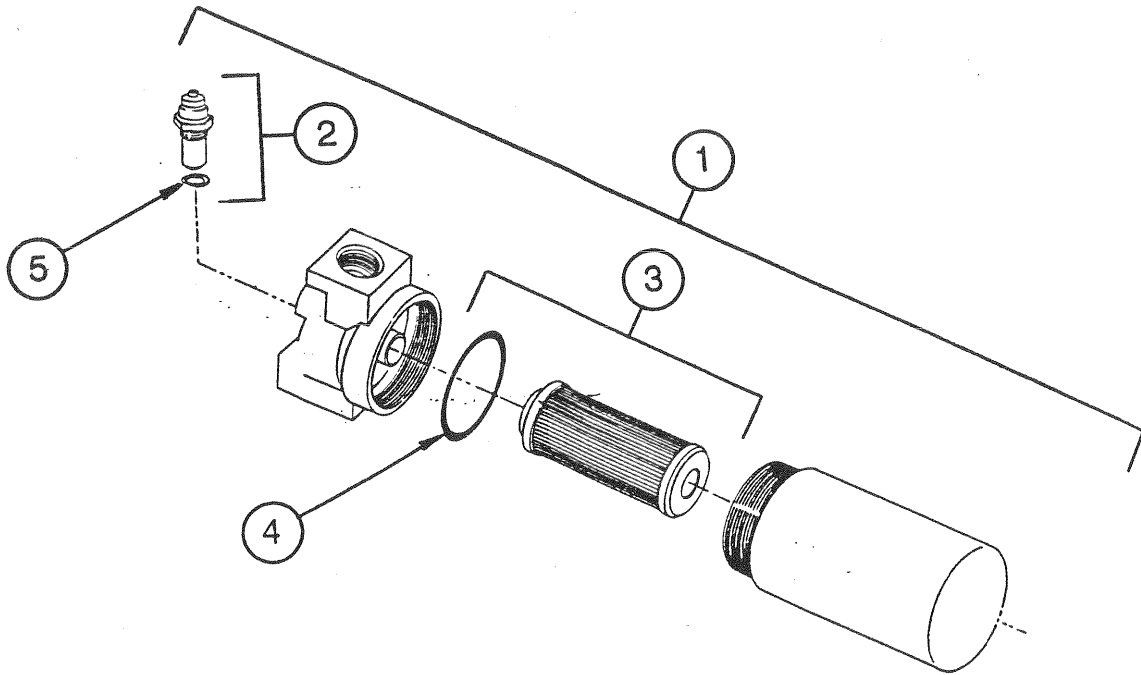

<u>ITEM</u>	<u>FLUID</u>	<u>PART NUMBER</u>	<u>DESCRIPTION</u>	<u>QTY.</u>
1	Mineral Base	HC-1478	Filter Assembly	1
	Phosphate Ester	HC-1505	Filter Assembly	1
2	Mineral Base	HC-1525	Clogging Indicator	1
	Phosphate Ester	HC-1528	Clogging Indicator	1

#### FILTER REPLACEMENT PARTS

3	Mineral Base	K-1894	Filter Element Kit	1
	Phosphate Ester	K-1895	Filter Element Kit	1

**Item 4 is included with Item 3.**

4	Mineral Base	HC-2000-240	O-ring, Bowl	1
	Phosphate Ester	HC-2006-240	O-ring, Bowl	1

#### CLOGGING INDICATOR REPLACEMENT PARTS

5	Mineral Base	HC-2010-912	O-ring	1
	Phosphate Ester	HC-2013-912	O-ring	1

## HYDRAULIC POWER UNIT

### Option 29—Reservoir Fill Hand Pump

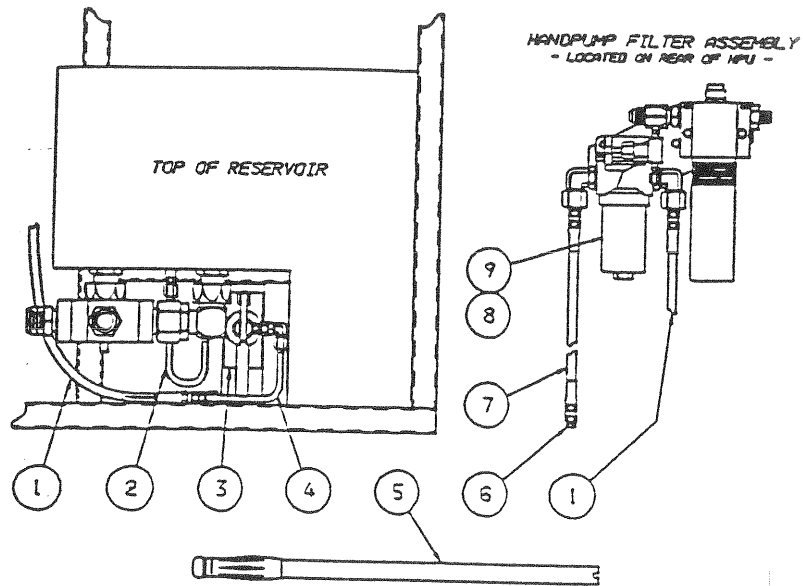

<u>ITEM</u>	<u>FLUID</u>	<u>PART NUMBER</u>	<u>DESCRIPTION</u>	<u>QTY.</u>
1	Mineral Base	TF-1043-02*51.0	Hose	1
	Phosphate Ester	TF-1041-11*51.0	Hose	1
2		Z-3073	Tube Assembly	1
3	Mineral Base	Z-2947	500 PSI Hand Pump Assembly	1
	Phosphate Ester	Z-2885	500 PSI Hand Pump Assembly	1
4		Z-2285	Tube Assembly	1
5		H-1009-01	Pump Handle	1
6		H-2014-03-S	Plug	1
7	Mineral Base	TF-1043-01*180	Hose	1
	Phosphate Ester	TF-1041-05*180	Hose	1
8	Mineral Base	HC-1481	Filter Assembly	1
	Phosphate Ester	HC-1481	Filter Assembly	1
9	Mineral Base	K-1742	Replacement Filter Element Kit	1
	Phosphate Ester	K-1743	Replacement Filter Element Kit	1

05-7022-XXXX

## HYDRAULIC POWER UNIT

Z-2947 Mineral Base Hand Pump Assembly (MB)

Z-2885 Phosphate Ester Hand Pump Assembly (PE)

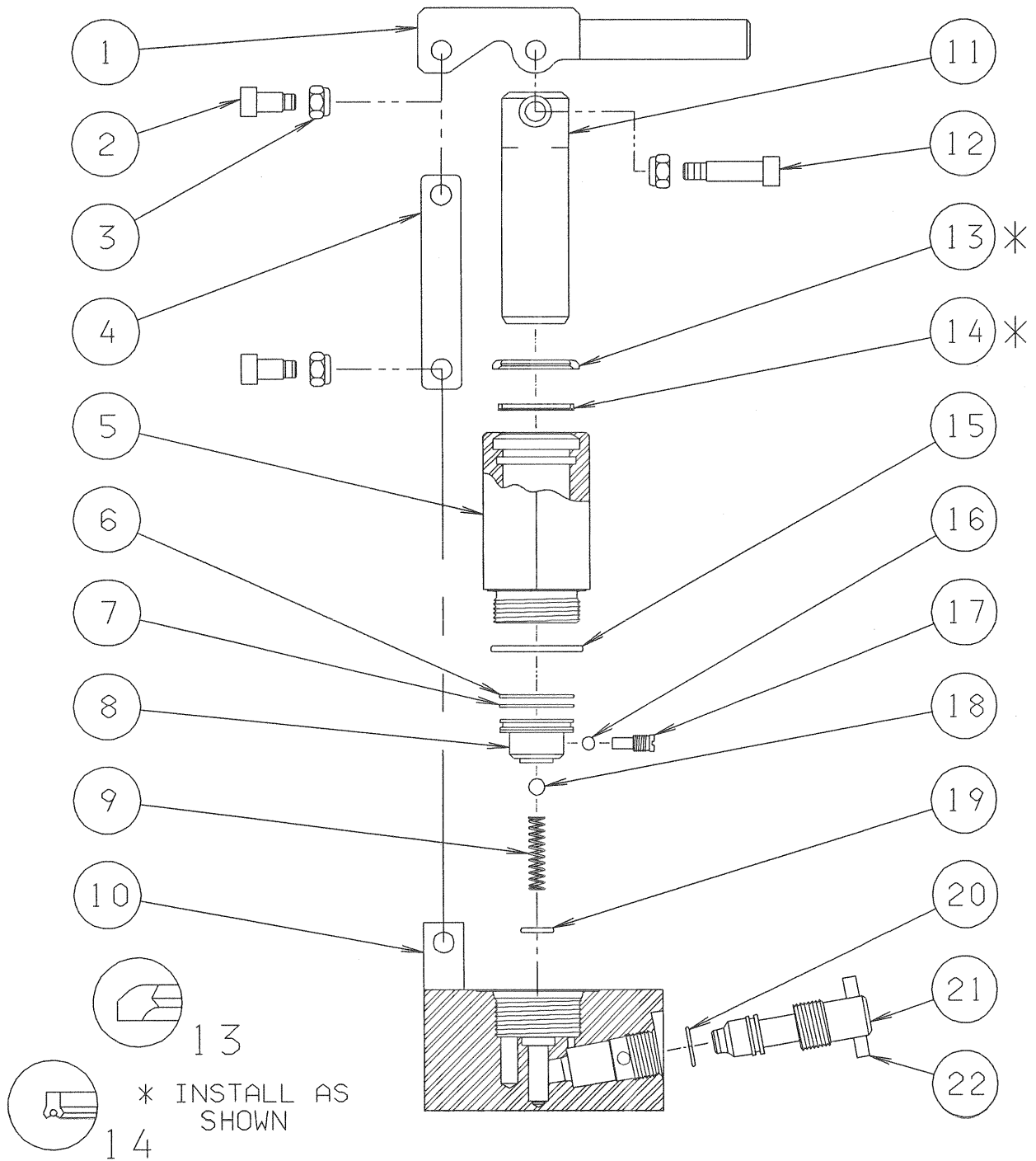

# TRONAIR

05-7022-XXXX

## HYDRAULIC POWER UNIT

### REPLACEMENT KITS

<u>ITEM</u>	<u>DESCRIPTION</u>	<u>QTY</u>
<b>K-2242</b>	<b>Linkage Kit; consists of:</b>	
- Item 1	Pump Handle	1
- Item 2	Socket Head Screw	2
- Item 3	Elastic Stopnut	3
- Item 4	Pump Strap	2
- Item 12	Socket Head Screw	1
<b>K-2440 (MB)</b>	<b>Release Screw Kit; consists of:</b>	
<b>K-2441 (PE)</b>		
- Item 20	O-ring	1
- Item 21	Release Screw	1
- Item 22	Roll Pin	1
- Item 23	Pan Head Screw (Not shown)	1
<b>K-2442</b>	<b>Piston/Cylinder Kit; consists of:</b>	
- Item 5	Cylinder	1
- Item 8	Valve Body	1
- Item 11	Piston	1
<b>K-2443</b>	<b>Internal Parts Kit; consists of:</b>	
- Item 9	Pressure Spring	1
- Item 16	Ball, 1/4" diameter	1
- Item 17	Valve Screw	1
- Item 18	Ball, 5/16" diameter	1
<b>K-2444 (MB)</b>	<b>Soft Goods Kit; consists of:</b>	
<b>K-2445 (PE)</b>		
- Item 6	O-ring	1
- Item 7	Backup Ring	1
- Item 13	Rod Wiper	1
- Item 14	Polypak Ring	1
- Item 15	O-ring	1
- Item 19	O-ring	1
- Item 20	O-ring	1