

Models: 06-4005-Series
06-4005-0511, 06-4005-0520, 06-4005-0800,
06-4005-3300, 06-4005-3611
Component Pressure Test Unit



11/2014 - Rev. 01

REVISION
01

DATE
11/2014

TEXT AFFECTED
Original release

TABLE OF CONTENTS

	<u>PAGE</u>
1.0 PRODUCT INFORMATION	1
1.0 DESCRIPTION	1
1.2 MODEL & SERIAL NUMBER	1
1.3 MANUFACTURER	1
2.0 SPECIFICATIONS	1
3.0 FEATURES	1
4.0 PREPARATION FOR USE	1
5.0 TRAINING	1
5.1 TRAINING REQUIREMENTS	1
6.0 OPERATION	1
6.1 TO USE YOUR Test Unit	1
6.2 TO MAINTAIN SYSTEM PRESSURE	1
6.3 WHEN SERVICE HAS BEEN COMPLETED	2
6.4 COMPONENT TESTING	2
7.0 TROUBLE SHOOTING	2
8.0 MAINTENANCE	2
7.1 REMOVING AND SERVICING PUMP	2
8.2 FILTER MAINTENANCE	2
9.0 PROVISION OF SPARES	2
9.1 SOURCE OF SPARE PARTS	2
9.2 RECOMMENDED SPARE PARTS LISTS	2
10.0 IN SERVICE SUPPORT	2
11.0 GUARANTEES/LIMITATION OF LIABILITY	3

This product can not be modified without the written approval of Tronair, Inc. Any modifications done without written approval voids all warranties and releases Tronair, Inc., its suppliers, distributors, employees, or financial institutions from any liability from consequences that may occur. Only Tronair OEM replacement parts shall be used.

1.0 PRODUCT INFORMATION

1.0 DESCRIPTION

The Tronair 06-4005-Series Component Pressure Test Unit is a compact unit designed to provide a source of clean, pressurized fluid for filling reservoirs, bleeding brakes and other maintenance functions.

1.2 MODEL & SERIAL NUMBER

Reference nameplate on unit

1.3 MANUFACTURER

TRONAIR, Inc.
1 Air Cargo Pkwy East
Swanton, Ohio 43558 USA

Telephone: (419) 866-6301 or 800-426-6301
Fax: (419) 867-0634
E-mail: sales@tronair.com
Website: www.tronair.com

2.0 SPECIFICATIONS

- Tank Capacity: .90 gal (3.4 lt)
- Filtration: 2 Micron
- Maximum Pressure: 3,000 psig (206.8 bar)
- Weight: 25 lbs (11.3 kg)
- Fluids:
 - 06-4005-0511, 06-4005-0520 MIL-PRF-5606/MIL-PRF-83282
 - 06-4005-3300 Phosphate Ester – HyJet V
 - 06-4005-3611 Phosphate Ester
 - 06-4005-0800 MIL-L-23699/MIL-PRF-87257

3.0 FEATURES

- 15 Foot Hose (4.6 m)
- Certified 5,000 psi (344.7 bar) Pressure Gauge
- Pressure Isolation Valve

4.0 PREPARATION FOR USE

The Test Unit is shipped fully assembled, and only the following steps are required to make the unit operational:

1. Install appropriate fluid label
2. Service reservoir; fill reservoir with appropriate clean fluid. *Reference 2.0 Specifications*

Remove Air from Test Unit System by Completing the Following Steps:

1. Close manual pump release screw (lower right corner of pump base block)
2. Open isolation ball valve (located on side of unit)
3. Flow fluid by actuating manual pump

5.0 TRAINING

5.1 TRAINING REQUIREMENTS

The employer of the operator is responsible for providing a training program sufficient for safe operation.

6.0 OPERATION

6.1 TO USE YOUR Test Unit

1. Securely attach hose to the aircraft
2. Close pump release screw
3. Transfer hydraulic fluid by actuating the manual hydraulic pump

6.2 TO MAINTAIN SYSTEM PRESSURE

1. Follow procedures in section 5.1
2. Close isolation ball valve at desire pressure
3. Read system pressure from pressure gauge (allow time for pressure drop, if required)
4. Open isolation ball valve to relieve pressure

6.0 OPERATION (continued)

6.3 WHEN SERVICE HAS BEEN COMPLETED

1. Open pump release screw to relieve hydraulic pressure
2. Disconnect hose from aircraft
3. Install hose end dust plug

6.4 COMPONENT TESTING

A shut-off valve has been provided to assure no back flow of fluid and therefore is to be closed after the required pressure has built up in the system

Pressure is relieved by opening this shut-off valve and pump release screw.

7.0 TROUBLE SHOOTING

Probable Cause	Corrective Action
High pressure leaks (at joint, plugs or tubing)	Re-tighten or repair
Leaky discharge check valve	Pump rapidly to dislodge; or repair pump
Leaky release valve	Tighten release valve
Leaky pump O-ring packing	Repair pump
Lack of oil	Refill reservoir check system for leaks
Sticking inlet check valve	Pump rapidly to dislodge; or repair pump
Closed air vent	Open air vent

8.0 MAINTENANCE

7.1 REMOVING AND SERVICING PUMP

NOTE: If pump is found faulty, call the factory for replacement or replace seals as follows:

1. Review Appendix II: Hand Pump Parts List during the following procedure.
2. Clamp suction (push on) hose and remove hose from pump.
3. Uncouple fitting of hydraulic hose from pump.
4. Remove pump from unit.
5. Remove cotter pin (Item 18) from clevis pin.
6. Remove four (4) socket head cap screws.
7. Remove flanges.
8. Remove tube assembly (Item 16).
9. Replace O-rings and backup ring. (See Appendix II: for available kits.)
10. Re-assemble in reverse order.

8.2 FILTER MAINTENANCE

- The filter is of a non-bypass design with a replaceable element. As the filter element becomes clogged, higher handle force may be required for a given flow rate. High handle force while in a re-circulating or other “free flow” condition indicates the need for filter element replacement.
- DO NOT force the pump handle when a clogged filter element is suspected.
- It is best to set up a filter maintenance schedule based on usage and actual fluid samples. For units with low usage, the filter element should be changed at least once annually.

9.0 PROVISION OF SPARES

9.1 SOURCE OF SPARE PARTS

Spare parts may be obtained from the manufacturer:

TRONAIR, Inc.
1 Air Cargo Pkwy East
Swanton, Ohio 43558 USA

Telephone: (419) 866-6301 or 800-426-6301
Fax: (419) 867-0634
E-mail: sales@tronair.com
Website: www.tronair.com

9.2 RECOMMENDED SPARE PARTS LISTS

Reference the following pages for Replacement Parts and Kits available.

10.0 IN SERVICE SUPPORT

Contact Tronair, Inc. for technical services and information. See Section 1.3 – Manufacturer.

11.0 GUARANTEES/LIMITATION OF LIABILITY

Tronair products are warranted to be free of manufacturing or material defects for a period of one year after shipment to the original customer. This is solely limited to the repair or replacement of defective components. This warranty does not cover the following items:

- a) Parts required for normal maintenance
- b) Parts covered by a component manufacturers warranty
- c) Replacement parts have a 90-day warranty from date of shipment

If you have a problem that may require service, contact Tronair immediately. Do not attempt to repair or disassemble a product without first contacting Tronair, any action may affect warranty coverage. When you contact Tronair be prepared to provide the following information:

- a) Product Model Number
- b) Product Serial Number
- c) Description of the problem

If warranty coverage is approved, either replacement parts will be sent or the product will have to be returned to Tronair for repairs. If the product is to be returned, a Return Material Authorization (RMA) number will be issued for reference purposes on any shipping documents. Failure to obtain a RMA in advance of returning an item will result in a service fee. A decision on the extent of warranty coverage on returned products is reserved pending inspection at Tronair. Any shipments to Tronair must be shipped freight prepaid. Freight costs on shipments to customers will be paid by Tronair on any warranty claims only. Any unauthorized modification of the Tronair products or use of the Tronair products in violation of cautions and warnings in any manual (including updates) or safety bulletins published or delivered by Tronair will immediately void any warranty, express or implied.

The obligations of Tronair expressly stated herein are in lieu of all other warranties or conditions expressed or implied. **Any unauthorized modification of the Tronair products or use of the Tronair products in violations of cautions and warnings in any manual (including updates) or safety bulletins published or delivered by Tronair will immediately void any warranty, express or implied and Tronair disclaims any and all liability for injury (WITHOUT LIMITATION and including DEATH), loss or damage arising from or relating to such misuse.**

This page left blank intentionally.

Parts List

06-4005-0511, 06-4005-0800, 06-4005-3300, 06-4005-3611

When ordering Replacement Parts/Kits, please specify model, serial number and color of your product.

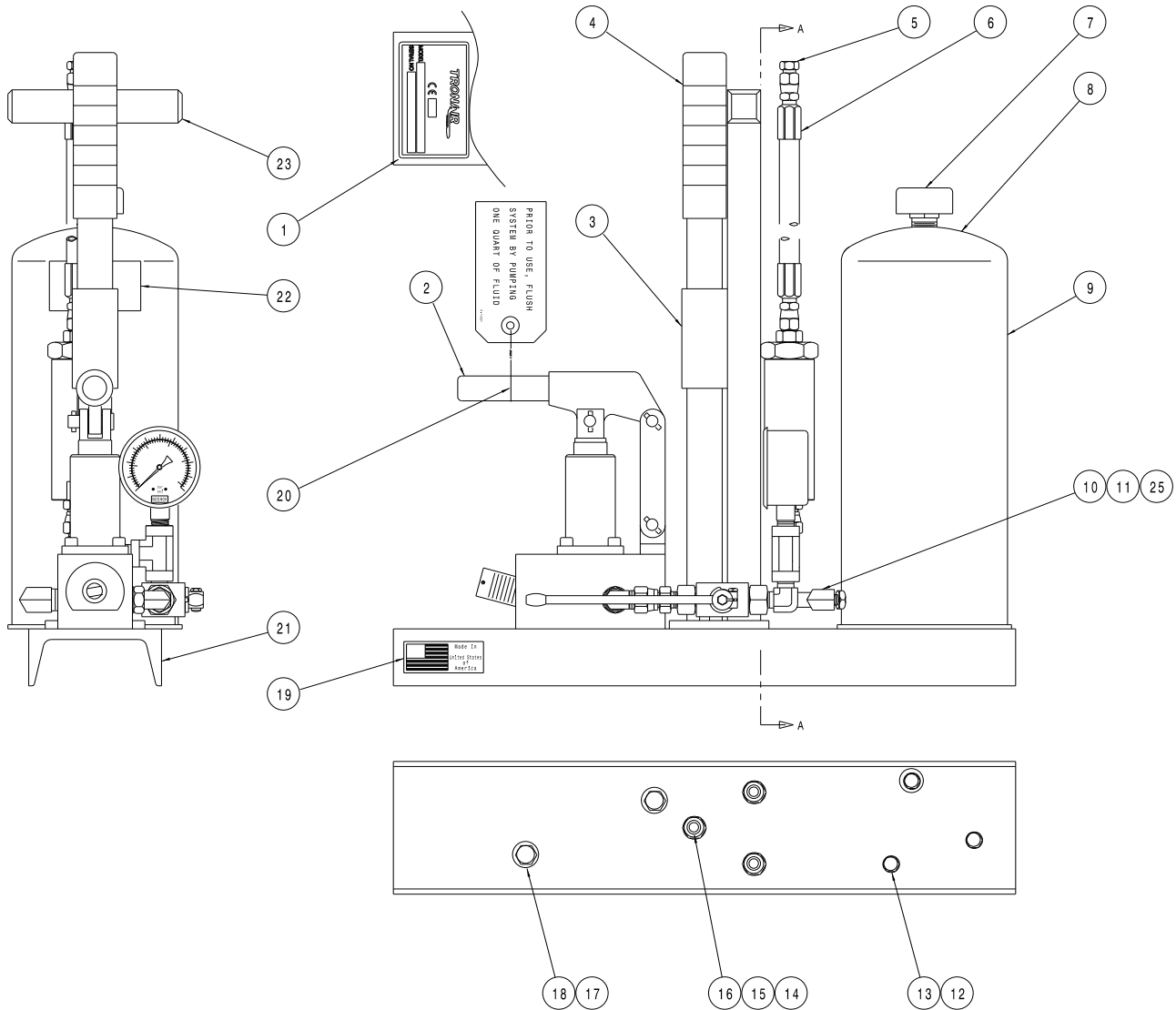

Item	Part Number	Description	Qty
1	V-1779	Label, Serial Number CE	1
3	Z-1291-01	Assembly, Handle	1
4	H-1009-02	Handle, Hand Pump	1
5	N-2014-03-S	Plug, #4 JIC	1
7	H-1045	Vent, Breather	1
8	HC-2328	Reservoir, Translucent 1 Gallon	1
9	V-1198	Label, Tronair	1
12	G-1255-05	Washer, AN ¼	3
13	G-1100-105006	Bolt, HH Grade 5, ¼ - 20 x ¾ Long	3
14	G-1100-106512	Bolt, HH 5/16 - 24 x 1 ¼ Long	3
15	G-1250-1060N	Flatwasher, 5/16 Narrow	3
16	G-1202-1065	ESN, 5/16 - 24	3
17	G-1251-1070R	Lockwasher, ⅜ Regular	2
18	G-1100-107010	Bolt, HH ⅝ - 16 x 1 Long	2
19	V-1001	Label, Made IN USA	1

Parts List

06-4005-0511, 06-4005-0800, 06-4005-3300, 06-4005-3611

When ordering Replacement Parts/Kits, please specify model, serial number and color of your product.

Item	Part Number	Description	Qty
20	V-1431	Tag, Flush System	1
21	D-016-01	Plate, Base	1
23	H-1143	End Cap	2
25	H-1516-08	Clamp, 2 Ear Hose	1

THE FOLLOWING PARTS ARE FLUID SPECIFIC

Parts List - 06-4005-0511 MIL-PRF-5606/MIL-PRF-83282

Item	Part Number	Description	Qty
2	Z-4284-01	Assembly, Hand Pump	1
6	TF-1043-01*180	Assembly, Hose, #4	1
10	N-2653-01-S-B	Elbow, Male ¼ Hose x SAE #4 Port	1
11	TF-1047-01*07.0	Hose, Push-On ¼	1
22	V-1101	Label, Use MIL-PRF-5605	
Not Shown	V-1102	Label, MIL-PRF-83282	1

Parts List - 06-4005-0800 MIL-PRF-87257/MIL-L-23699

Item	Part Number	Description	Qty
2	Z-4284-03	Assembly, Hand Pump	1
6	TF-1038-14*180	Assembly, Hose, #4	1
10	N-2653-01-S-V	Elbow, Male ¼ Hose x SAE #4 Port	1
11	TF-1105-04*07.0	Hose, Push-On ¼	1
22	V-2051	Label, Use MIL-PRF-87257	
Not Shown	V-1035	Label, MIL-L-23699	1

Parts List - 06-4005-3300 HyJet V

Item	Part Number	Description	Qty
2	Z-4284-02	Assembly, Hand Pump	1
6	TF-1041-05*180	Assembly, Hose, #4	1
10	N-2653-01-S-E	Elbow, Male ¼ Hose x SAE #4 Port	1
11	TF-1030-01*07.0	Hose, Push-On ¼	1
22	V-2585	Label, HyJET V Fluid Only	1

Parts List - 06-4005-3611 Phosphate Ester

Item	Part Number	Description	Qty
2	Z-4284-02	Assembly, Hand Pump	1
6	TF-1041-05*180	Assembly, Hose, #4	1
10	N-2653-01-S-E	Elbow, Male ¼ Hose x SAE #4 Port	1
11	TF-1030-01*07.0	Hose, Push-On ¼	1
22	V-1100	Label, Use Phosphate Ester Fluid Only	1

Parts List 06-4005-0520

When ordering Replacement Parts/Kits, please specify model, serial number and color of your product.

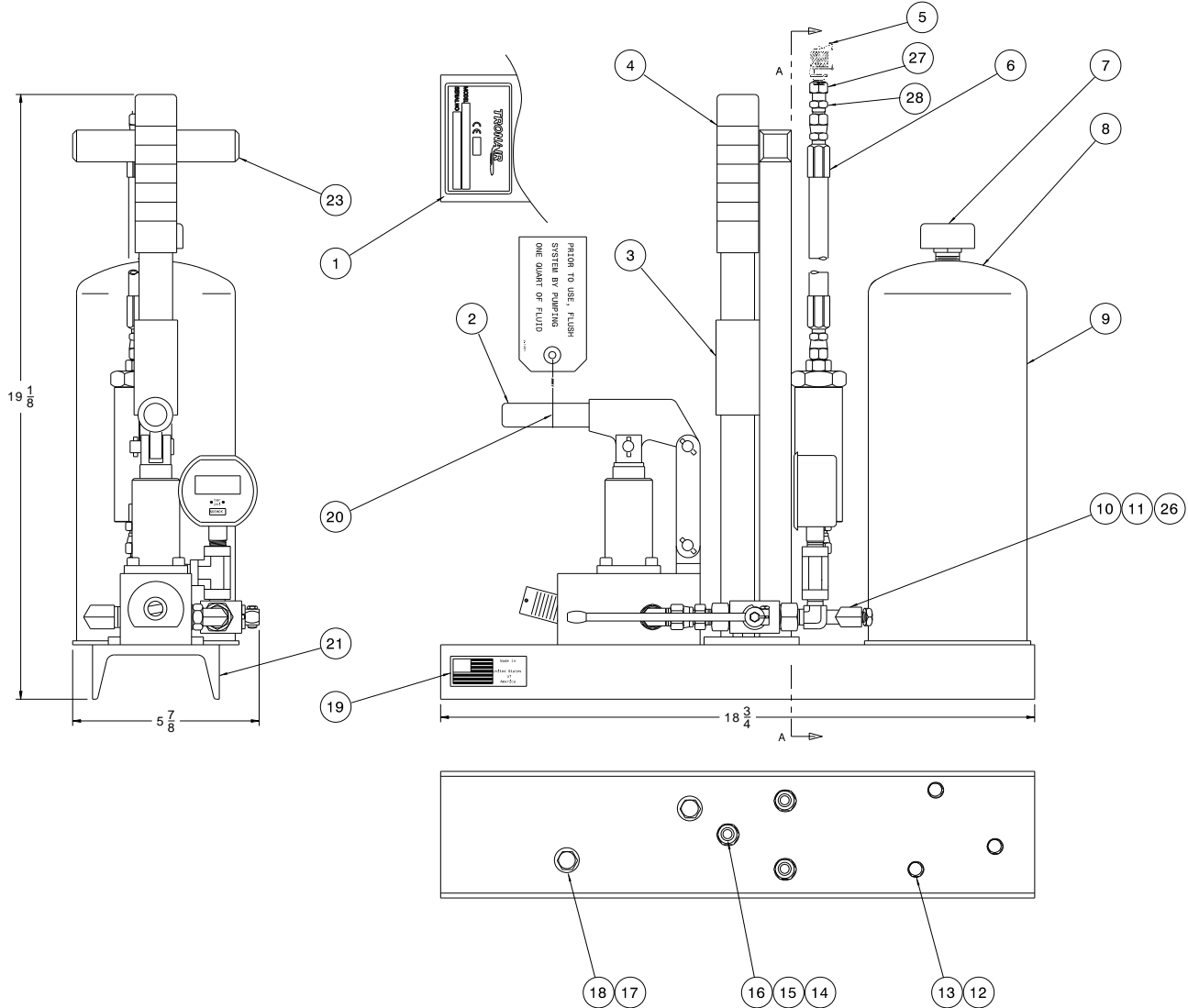

Item	Part Number	Description	Qty
1	V-1779	Label, Serial Number CE	1
2	Z-8477-01	Assembly, Hand Pump	1
3	Z-1291-01	Assembly, Handle	1
4	H-1009-02	Handle, Hand Pump	1
5	N-2931	Adapter, Test Points	1
6	TF-1043-01*180	Assembly, Hose #4	1
7	H-1045	Vent, Breather	1
8	HC-2328	Reservoir, Translucent 1 Gallon	1
9	V-1198	Label, Tronair	1
10	N-2653-01-S-B	Elbow, Male, ¼ Hose x SAE #4 Port	1
11	TF-1047-01*07.0	Hose, Push-On ¼	1
12	G-1255-05	Washer, AN ¼	3
13	G-1100-105006	Bolt, HH Grade 5, ¼ - 20 x ¾ Long	3
14	G-1100-106512	Bolt, HH 5/16 - 24 x 1 ¼ Long	3
15	G-1250-1060N	Flatwasher, 5/16 Narrow	3

Parts List

When ordering Replacement Parts/Kits, please specify model, serial number and color of your product.

Item	Part Number	Description	Qty
16	G-1202-1065	ESN, 5/16 – 24	3
17	G-1251-1070R	Lockwasher, 3/8 Regular	2
18	G-1100-107010	Bolt, HH 3/8 - 16 x 1 Long	2
19	V-1001	Label, Made IN USA	1
20	V-1431	Tag, Flush System	1
21	D-016-01	Plate, Base	1
22	V-1102	Label, MIL-PRF-83282	1
23	H-1143	End Cap	2
26	H-1516-08	Clamp, 2 Ear Hose	1
27	N-2934	Adapter, Male NPTF to Female Metric	1
28	N-2010-03-S	Connector, Female	1
<i>Not Shown</i>	V-1101	Label, Use MIL- PRF-83282	1



APPENDIX I

Instrument Certification Notice



Instrument Certification Notice

The gauge Certificates of Calibration supplied for the gauge(s) on this unit contain the calibration data for the actual instrument calibrated, along with the calibration date of the **STANDARD** used to perform the calibration check.

The due date for re-calibration of the instrument should be based upon the date the instrument was placed in service in your facility. Re-calibration should be done on a periodic basis as dictated by the end user's quality system or other overriding requirements.

Note that Tronair, Inc. does not supply certificates of calibration on flow meters or pyrometers unless requested at the time of placed order. These instruments are considered reference indicators only and are not critical to the test(s) being performed on the aircraft.



APPENDIX II

Model: 06-4005-0511

**HC-1751
Hand Pump Parts List**



**Model: HC-1751
3250 PSI
Hand Pump**

**Parts List
With
Illustrations**

08/2001 – Rev. OR

Parts List

This pump is compatible with MIL-PRF-5606/MIL-H-83282 Hydraulic Fluids only.

Reference Parts List Illustration on following page

Item	Part Number	Description	Qty
3	5M1-000-001	Body, Pump	1
12	506-000	Half, Flange	4
25	518-000	Screw, Socket Head Cap	4
Not Shown	H-1009-01	Handle	1
	K-1001	Kit, Seal Replacement; consists of:	
4		O-ring, Release Screw	1
6		O-ring, Outlet Check	1
11		O-ring, Valve Body	1
21		Wiper, Rod	1
22		Ring, Backup	1
23		O-ring, Piston	1
27		O-ring, Tube Seal	1
◆ Not Shown		O-ring, Inlet Check	1
◆ Not Shown		O-ring, Guide Shoe	2
◆ Not Shown		Shoe, Piston Guide	1
	K-1068	Kit, Linkage Replacement; consists of:	
13		Pivot	1
14		Assembly, Linkage Pin	2
17		Strap	2
18		Assembly, Clevis Pin	1
19		Bracket, Pump Handle	1
	K-1069	Kit, Internal Parts Replacement; consists of:	
7		Spring, Inlet Check	1
8		Spring, Outlet Check	1
9		Ball, Outlet Check	1
10		Ball, Inlet Check	1
Not Shown		Ball, Release	1
	K-1778	Kit, Piston/Cylinder Replacement; consists of:	
15		Piston	1
16		Tube	1
20		Retainer, Wiper	1
24		Assembly, Valve Body (Includes Items 7, 10, 24, 26)	1
	K-1906	Kit, Piston/Seal Replacement; consists of:	
15		Piston	1
22		Ring, Backup	1
23		O-ring, Piston	1
	K-2782	Kit, Release Screw Replacement; consists of:	
2		Screw, Release	1
30		Retainer, Screw	1

◆ Although this item is listed in its particular kit, it is not used on HC-1751-01 pump. These items may be discarded.

NOTE: Entire pump assembly can be purchased as a kit. See Hydraulic Jack Parts list.

Parts List Illustration

This pump is compatible with MIL-PRF-5606 / MIL-H-83282 Hydraulic Fluids only.

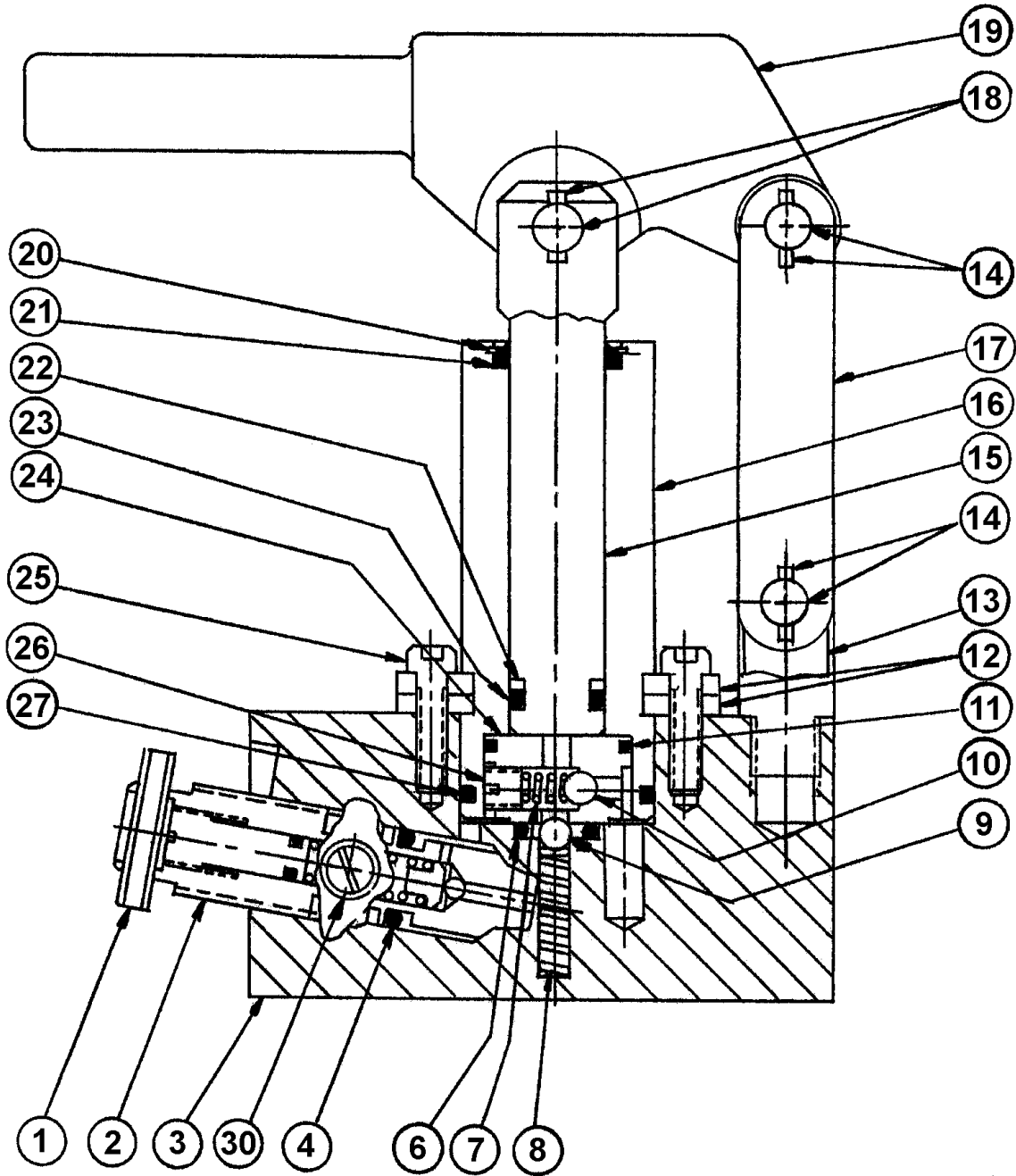

WARNING

Item 2 is a preset relief valve. Do Not disassemble this valve.
Replacement parts are available as a preset relief valve assembly.



APPENDIX III

Model: 06-4005-0800

**HC-2253
Hand Pump Parts List**



**Model: HC-2253
3250 PSI
Hand Pump**

**Parts List
With
Illustrations**

08/2001 – Rev. OR

Parts List

This pump is compatible with MIL-PRF-5606/MIL-H-83282 Hydraulic Fluids only.

Reference Parts List Illustration on following page

Item	Part Number	Description	Qty
3	5M1-000-001	Body, Pump	1
12	506-000	Half, Flange	4
25	518-000	Screw, Socket Head Cap	4
Not Shown	H-1009-01	Handle	1
	K-1001	Kit, Seal Replacement; consists of:	
4		O-ring, Release Screw	1
6		O-ring, Outlet Check	1
11		O-ring, Valve Body	1
21		Wiper, Rod	1
22		Ring, Backup	1
23		O-ring, Piston	1
27		O-ring, Tube Seal	1
◆ Not Shown		O-ring, Inlet Check	1
◆ Not Shown		O-ring, Guide Shoe	2
◆ Not Shown		Shoe, Piston Guide	1
	K-1068	Kit, Linkage Replacement; consists of:	
13		Pivot	1
14		Assembly, Linkage Pin	2
17		Strap	2
18		Assembly, Clevis Pin	1
19		Bracket, Pump Handle	1
	K-1069	Kit, Internal Parts Replacement; consists of:	
7		Spring, Inlet Check	1
8		Spring, Outlet Check	1
9		Ball, Outlet Check	1
10		Ball, Inlet Check	1
Not Shown		Ball, Release	1
	K-1778	Kit, Piston/Cylinder Replacement; consists of:	
15		Piston	1
16		Tube	1
20		Retainer, Wiper	1
24		Assembly, Valve Body (Includes Items 7, 10, 24, 26)	1
	K-1906	Kit, Piston/Seal Replacement; consists of:	
15		Piston	1
22		Ring, Backup	1
23		O-ring, Piston	1
	K-2782	Kit, Release Screw Replacement; consists of:	
2		Screw, Release	1
30		Retainer, Screw	1

◆ Although this item is listed in its particular kit, it is not used on HC-1751-01 pump. These items may be discarded.

NOTE: Entire pump assembly can be purchased as a kit. See Hydraulic Jack Parts list.

Parts List Illustration

This pump is compatible with MIL-PRF-5606 / MIL-H-83282 Hydraulic Fluids only.

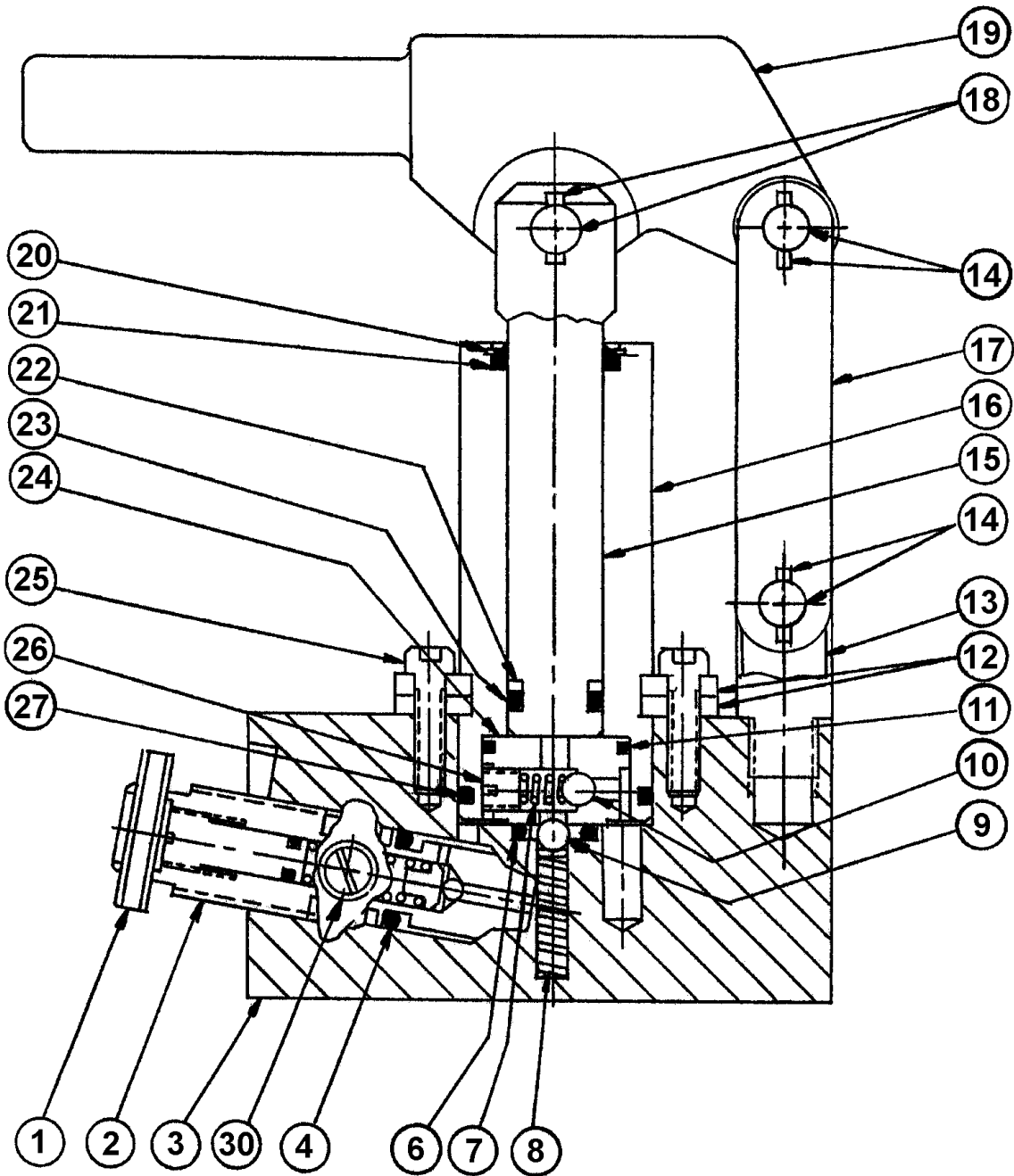

WARNING

Item 2 is a preset relief valve. Do Not disassemble this valve.
Replacement parts are available as a preset relief valve assembly.



APPENDIX IV

**Models: 06-4005-3300
06-4005-3611**

**HC-1754
Hand Pump Parts List**



**Model: HC-1754
3250 psi
Hand Pump**

**Parts List
With Illustrations**

09/2001 – Rev. OR

Parts List

This pump is compatible with Phosphate Ester Hydraulic Fluids only.

Reference Illustration on following page

Item	Part Number	Description	Qty
3	5M1-000-001	Body, Pump	1
12	506-000	Half, Flange	4
25	518-000	Screw, Socket Head Cap	4
Not Shown	H-1009-01	Handle	1
	K-1032	Kit, Seal Replacement; consists of:	
4		O-ring, Release Screw	1
6		O-ring, Outlet Check	1
11		O-ring, Valve Body	1
21		Wiper, Rod	1
22		Ring, Backup	1
23		O-ring, Piston	1
27		O-ring, Tube Seal	1
◆ Not Shown		O-ring, Inlet Check	1
◆ Not Shown		O-ring, Guide Shoe	2
◆ Not Shown		Shoe, Piston Guide	1
	K-1068	Kit, Linkage Replacement; consists of:	
13		Pivot	1
14		Assembly, Linkage Pin	2
17		Strap	2
18		Assembly, Clevis Pin	1
19		Bracket, Pump Handle	1
	K-1069	Kit, Internal Parts Replacement; consists of:	
7		Spring, Inlet Check	1
8		Spring, Outlet Check	1
9		Ball, Outlet Check	1
10		Ball, Inlet Check	1
Not Shown		Ball, Release	1
	K-1778	Kit, Piston/Cylinder Replacement; consists of:	
15		Piston	1
16		Tube	1
20		Retainer, Wiper	1
24		Assembly, Valve Body (Includes Items 7, 10, 24, 26)	1
	K-1909	Kit, Piston/Seal Replacement; consists of:	
15		Piston	1
22		Ring, Backup	1
23		O-ring, Piston	1
	K-2785	Kit, Release Screw Replacement; consists of:	
2		Screw, Release	1

◆ Although this item is listed in its particular kit, it is not used on HC-1754 pump. These items may be discarded.

NOTE: Entire pump assembly can be purchased as a kit. See Operation and Service Manual Parts List.



APPENDIX V

Declaration of Conformity



DECLARATION of CONFORMITY

The design, development and manufacture is in accordance with European Community guidelines

06-4005-Series

Relevant provisions complied with by the machinery:
2006/42/EC

Identification of person empowered to sign on behalf of the Manufacturer:

A handwritten signature in cursive script that reads "Patrick Finch". The signature is written in black ink and is positioned above a solid horizontal line that spans the width of the signature area.

Quality Assurance Representative