

**Model: 06-5042-Series**  
**06-5042-0500, 06-5042-0800, 06-5042-3300, 06-5042-3600**  
**Fluid Servicing Unit**

12/2014 – Rev. 05

REVISION

04

05

DATE

01/10/2004

12/2014

TEXT AFFECTED

Major revision

Added 06-5042-3300

**TABLE OF CONTENTS**

	<b><u>PAGE</u></b>
<b>1.0 GENERAL DESCRIPTION .....</b>	<b>1</b>
<b>2.0 SPECIFICATIONS .....</b>	<b>1</b>
<b>3.0 FEATURES .....</b>	<b>1</b>
<b>4.0 PREPARATION FOR USE .....</b>	<b>1</b>
<b>5.0 TRAINING .....</b>	<b>1</b>
5.1 TRAINING REQUIREMENTS .....	1
<b>6.0 OPERATION .....</b>	<b>1</b>
<b>7.0 MAINTENANCE .....</b>	<b>2</b>
7.1 TIRES .....	2
7.2 FILTERS .....	2
<b>8.0 PROVISION OF SPARES .....</b>	<b>2</b>
8.1 SOURCE OF SPARE PARTS .....	2
8.2 RECOMMENDED SPARE PARTS LISTS .....	2
<b>9.0 IN SERVICE SUPPORT .....</b>	<b>2</b>
<b>10.0 GUARANTEES/LIMITATION OF LIABILITY .....</b>	<b>2</b>

This product can not be modified without the written approval of Tronair, Inc. Any modifications done without written approval voids all warranties and releases Tronair, Inc., its suppliers, distributors, employees, or financial institutions from any liability from consequences that may occur. Only Tronair OEM replacement parts shall be used.

## 1.0 GENERAL DESCRIPTION

The Fluid Reservoir Service Unit is a compact unit primarily designed to provide a source of clean fluid for filling reservoirs. It is not intended for performing any pressure testing tasks.

## 2.0 SPECIFICATIONS

- Maximum Pressure: 200 psi (13.8 bar)
- Fluids:
  - MIL-PRF-5606/MIL-PRF-83282 ..... 06-5042-0500
  - MIL-L 23699/MIL-PRF-87257 ..... 06-5042-0800
  - HyJet V ..... 06-5042-3300
  - Phosphate Ester..... 06-5042-3600
- Filtration: 2 Micron
- Dimensions: 18 <sup>4</sup>/<sub>16</sub> in (47.5 cm) Wide  
23 <sup>3</sup>/<sub>16</sub> in (59cm) Deep  
34 <sup>5</sup>/<sub>16</sub> in (87 cm) High (Handle Extended)
- Weight: 60 lbs (27.2 kg)
- Pump Displacement: 4.4 cubic in/stroke (72.11 cc/stroke)

## 3.0 FEATURES

- 15 foot (4.6 m) hose
- 8 gallon (30.3 liter) reservoir
- 2 micron pressure filter

## 4.0 PREPARATION FOR USE

The unit is shipped fully assembled, and only the following steps are required to make it operational:

1. **Service Reservoir:** Fill reservoir with appropriate clean fluid.



### CAUTION!

**Only use the type of fluid for which the unit is designed. Using other fluids will cause contamination and seal deterioration.**

2. Adjust frame handle height to preference.
3. Operate hand pump several times to fill line and purge air. Install coupling at hose end if applicable.

## 5.0 TRAINING

### 5.1 TRAINING REQUIREMENTS

The employer of the operator is responsible for providing a training program sufficient for safe operation.

## 6.0 OPERATION

### To Use the Unit:

1. Securely attach hose to aircraft.
2. Operate pump handle at a slow to moderate pace with even pressure.

- NOTES:**
1. ***It is not necessary to operate pump rapidly. The pump moves a large volume of oil per stroke and will fill a reservoir much faster than standard pumps.***
  2. ***A slow movement of the pump handle with a steady pressure works best.***

### When Service Has Been Completed:

1. Disconnect hose from aircraft.
2. Replace protective cap on hose end to prevent dirt ingestion.

## 7.0 MAINTENANCE

### 7.1 TIRES

Maintain 45 to 50 psi (3.1 to 3.4 bar) tire pressure.

### 7.2 FILTERS

The filter is of a non-bypass design. This means that, if the filter becomes clogged, no fluid will pass to the aircraft and a high handle force will result. If this happens, replace filter element. Do not force the pump handle as damage to unit components could result.

Element replacement schedule should be based on usage and actual fluid samples. For units with low usage, element should be replaced at least once annually.

## 8.0 PROVISION OF SPARES

### 8.1 SOURCE OF SPARE PARTS

Spare parts may be obtained from the manufacturer:

**TRONAIR**, Inc.

1 Air Cargo Pkwy East

Swanton, Ohio 43558 USA

Telephone: (419) 866-6301 or 800-426-6301

Fax: (419) 867-0634

E-mail: sales@tronair.com

Website: www.tronair.com

### 8.2 RECOMMENDED SPARE PARTS LISTS

Reference the following pages for Replacement Parts and Kits available.

## 9.0 IN SERVICE SUPPORT

Contact Tronair, Inc. for technical services and information. See Section 1.3 – Manufacturer.

## 10.0 GUARANTEES/LIMITATION OF LIABILITY

Tronair products are warranted to be free of manufacturing or material defects for a period of one year after shipment to the original customer. This is solely limited to the repair or replacement of defective components. This warranty does not cover the following items:

- a) Parts required for normal maintenance
- b) Parts covered by a component manufacturers warranty
- c) Replacement parts have a 90-day warranty from date of shipment

If you have a problem that may require service, contact Tronair immediately. Do not attempt to repair or disassemble a product without first contacting Tronair, any action may affect warranty coverage. When you contact Tronair be prepared to provide the following information:

- a) Product Model Number
- b) Product Serial Number
- c) Description of the problem

If warranty coverage is approved, either replacement parts will be sent or the product will have to be returned to Tronair for repairs. If the product is to be returned, a Return Material Authorization (RMA) number will be issued for reference purposes on any shipping documents. Failure to obtain a RMA in advance of returning an item will result in a service fee. A decision on the extent of warranty coverage on returned products is reserved pending inspection at Tronair. Any shipments to Tronair must be shipped freight prepaid. Freight costs on shipments to customers will be paid by Tronair on any warranty claims only. Any unauthorized modification of the Tronair products or use of the Tronair products in violation of cautions and warnings in any manual (including updates) or safety bulletins published or delivered by Tronair will immediately void any warranty, express or implied.

The obligations of Tronair expressly stated herein are in lieu of all other warranties or conditions expressed or implied. **Any unauthorized modification of the Tronair products or use of the Tronair products in violations of cautions and warnings in any manual (including updates) or safety bulletins published or delivered by Tronair will immediately void any warranty, express or implied and Tronair disclaims any and all liability for injury (WITHOUT LIMITATION and including DEATH), loss or damage arising from or relating to such misuse.**

**Parts List – Reservoir Servicing Unit**

When ordering replacement parts/kits, please specify model, serial number and color of your unit.

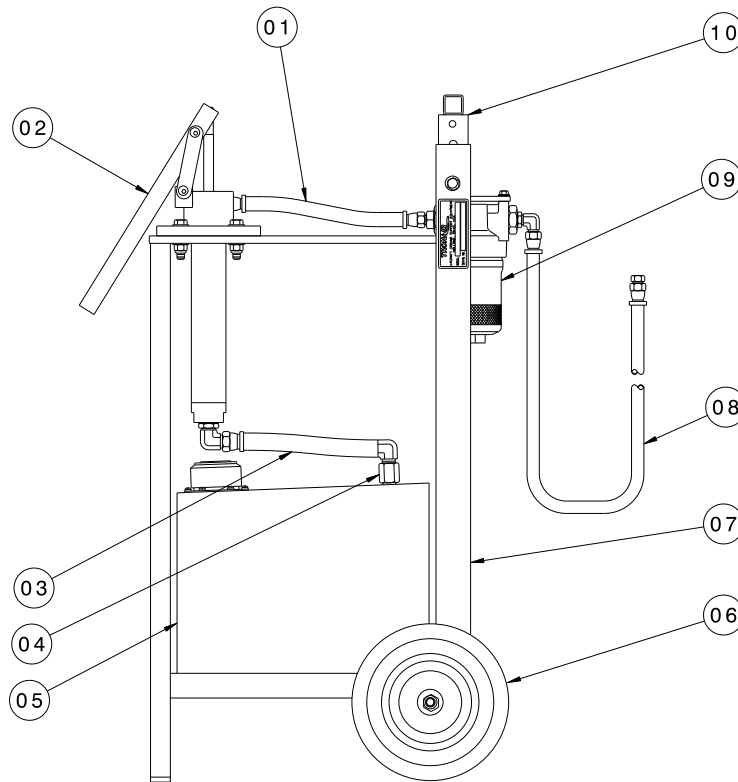

Item	Part Number	Description	Qty
4	Z-1273	Weldment, Tube	1
5	H-2665	Tank, Modified	1
6	U-1001-01	Wheel	2
7	Z-5589-01	Weldment, Frame	1
10	Z-1083-01	Handle, Unit	1

THE FOLLOWING PARTS ARE FLUID SPECIFIC

**Parts List - 06-5042-0500**  
MIL-PRF-5606/MIL-PRF-83282

Item	Part Number	Description	Qty
1	TF-1047-04*11.0	Assembly, Hose	1
◆ 2	HC-2156	Pump, Hand	1
3	TF-1047-05*09.5	Hose, Push-on	1
8	TF-1047-04*180	Assembly, Hose	1
9	HC-1481	Assembly, Filter	1

**Parts List - 06-5042-0800**  
MIL-PRF-87257/MIL-L-23699

Item	Part Number	Description	Qty
1	TF-1105-06*11.0	Assembly, Hose	1
◆ 2	HC-2171	Pump, Hand	1
3	TF-1105-08*09.5	Hose, Push-on	1
8	TF-1105-06*180	Assembly, Hose	1
9	HC-1826	Assembly, Filter	1

**Parts List - 06-5042-3300, 06-5042-3600**  
HyJet V, Phosphate Ester

Item	Part Number	Description	Qty
1	TF-1134-01*10.5	Assembly, Hose	1
◆ 2	HC-2157	Pump, Hand	1
3	TF-1030-03*09.5	Hose, Push-on	1
8	TF-1134-01*180	Assembly, Hose	1
9	HC-1480	Assembly, Filter	1

◆ Reference following page – Section View and Kit Listings for Item 2 (Hand Pump)

HC-2171/HC-2157/HC-2156 Hand Pump

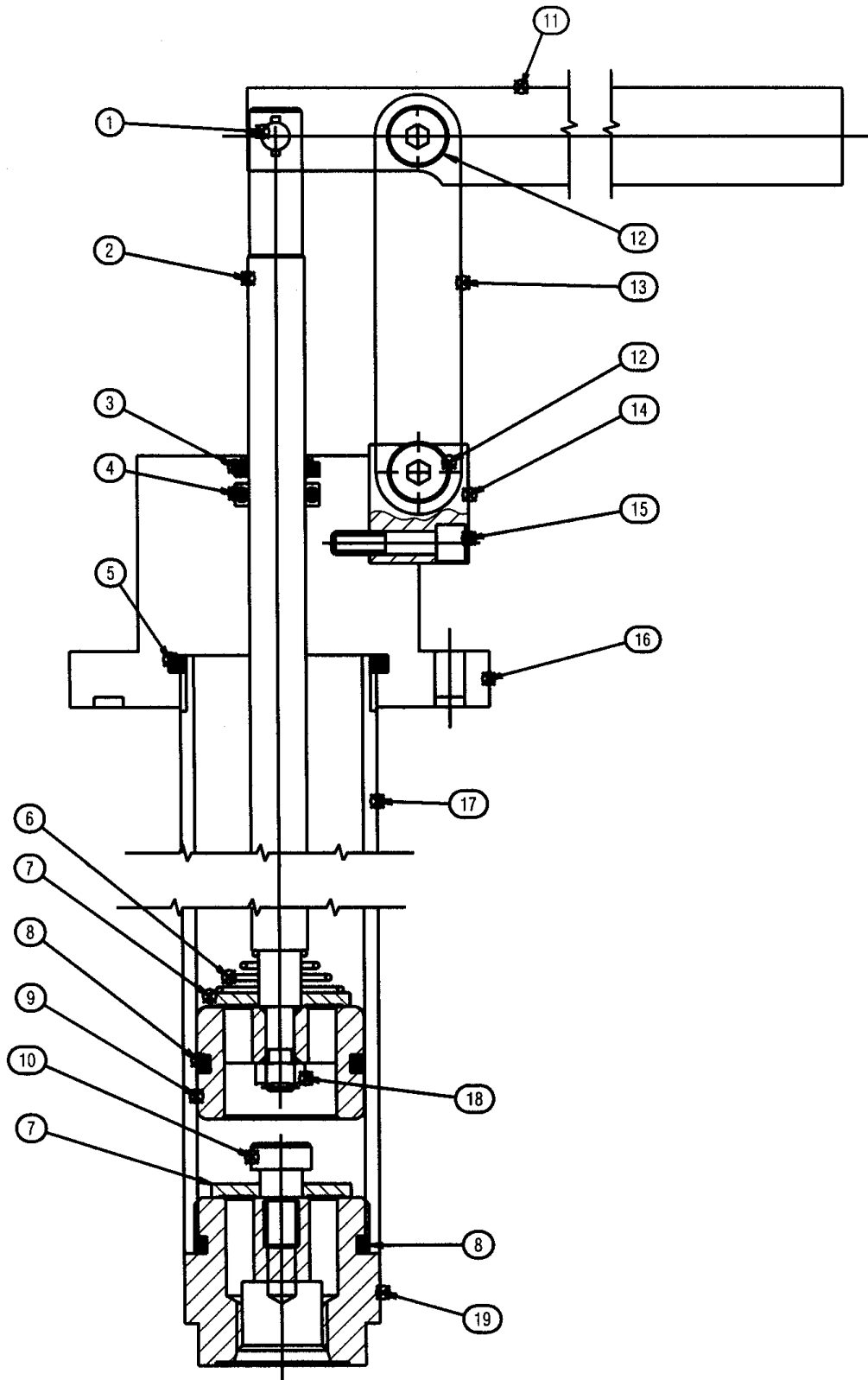



### Parts List

When ordering replacement parts/kits, please specify model, serial number and color of your unit.

Item	Part Number	Description	Qty
2	CXD-020004-004	Piston Rod	1
6	CENT-TA-2098	Spring	1
7	CXD-020004-006	Flapper	2
9	CDX-020004-005	Piston	1
10	09-AHDF-06-18 x 04	Shoulder Screw	1
13	512-000	Strap	2
14	CXD-020004-009	Mounting Block	1
15	09-ADDF-0J-32 x 14	Socket Head Cap Screw	1
16	CXD-020004-002	Cap & Mounting Flange	1
17	CXD-020004-003	Tube	1
18	08-ADFH-04-28	Prevailing Locknut	1
19	CXD-020004-001	End Cap, Blind End	1
	<b>HK-3717</b>	<b>Kit, Handle Replacement; consists of:</b>	1
1		Pin Linkage Assembly	1
11		Pump Handle	1
12		Pin Linkage Assembly	2
<b>HC-2157 (Phosphate Ester, HyJet V Fluid) 06-5042-3300, 06-5042-3600</b>			
	<b>HK-3683</b>	<b>Kit, Pump Seal Replacement; consists of:</b>	1
3		Wiper, BUNA	1
4		O-ring, BUNA	1
5		O-ring, BUNA	1
8		O-ring, BUNA	2
<b>HC-2171 (MIL-L-23699, MIL-PRF-87257) 06-5042-0800</b>			
	<b>HK-3715</b>	<b>Kit, Pump Seal Replacement; consists of:</b>	1
3		Wiper, BUNA	1
4		O-ring, BUNA	1
5		O-ring, BUNA	1
8		O-ring, BUNA	2
<b>HC-2156 (MIL-PRF-5606, MIL-PRF-83282) 06-5042-0500</b>			
	<b>HK-3682</b>	<b>Kit, Pump; consists of:</b>	1
3		Wiper, BUNA	1
4		O-ring, BUNA	1
5		O-ring, BUNA	1
8		O-ring, BUNA	2

**Parts List – Filter Assembly**

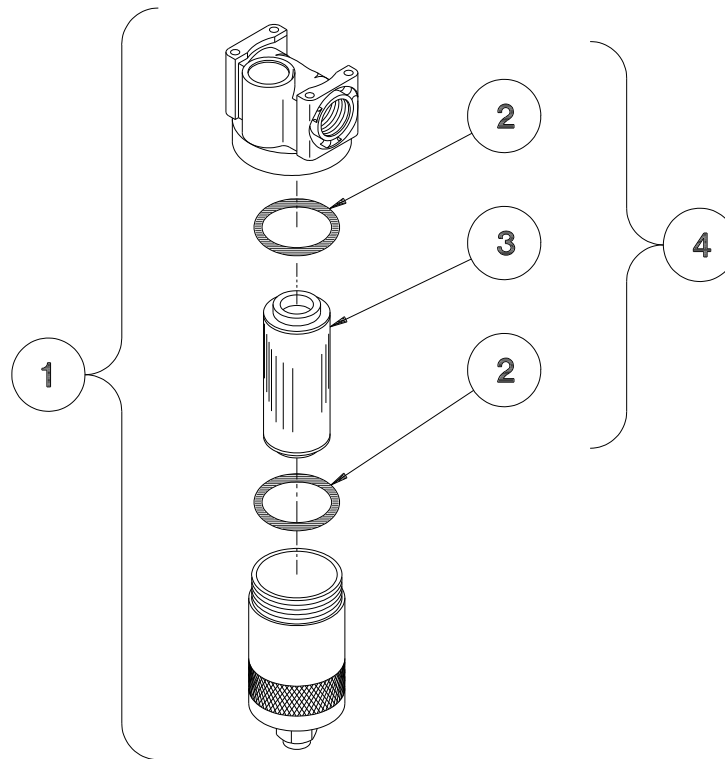

**Parts List - 06-5042-0500**  
MIL-PRF-5606/MIL-PRF-83282

Item	Part Number	Description	Qty
1	HC-1481	Assembly, Filter	1
2	HC-2007-142	O-Ring, Series 2 (VITON)	2
3	HC-1482	Element, Filter	1
4	K-3098	Kit, Filter Element	1

**Parts List - 06-5042-0800**  
MIL-PRF-87257/MIL-L-23699

Item	Part Number	Description	Qty
1	HC-1826	Assembly, Filter	1
2	HC-2007-142	O-Ring, Series 2 (VITON)	2
3	HC-1482	Element, Filter	1
4	K-3098	Kit, Filter Element	1

**Parts List - 06-5042-3300, 06-5042-3600**  
HyJet V, Phosphate Ester

Item	Part Number	Description	Qty
1	HC-1480	Assembly, Filter	1
2	HC-2006-142	O-Ring, Series 2 (ERP)	2
3	HC-1483	Element, Filter	1
4	K-3099	Kit, Filter Element	1