



OPERATION & SERVICE MANUAL

Model: 07-3020-6900 Fuel Sample Unit

07/2023 – Rev. 03

**For Spare Parts, Operations & Service Manuals or Service Needs
Scan the QR code or visit [Tronair.com/aftermarket](https://www.tronair.com/aftermarket)**



REVISION
03

DATE
07/2023

TEXT AFFECTED
Major revision

TABLE OF CONTENTS

	<u>PAGE</u>
1.0 PRODUCT INFORMATION	1
1.1 DESCRIPTION.....	1
1.2 MODEL & SERIAL NUMBER.....	1
1.3 MANUFACTURER.....	1
1.4 USAGE	1
1.5 SPECIFICATIONS	1
2.0 SAFETY INFORMATION.....	1
2.1 USAGE AND SAFETY INFORMATION.....	1
2.1 PERSONAL PROTECTION EQUIPMENT.....	1
3.0 TRAINING.....	2
3.1 TRAINING REQUIREMENTS	2
3.2 TRAINING PROGRAM	2
3.3 OPERATOR TRAINING.....	2
4.0 PRE-USE CHECKS	2
5.0 OPERATION.....	2
6.0 PACKAGING AND STORAGE.....	3
7.0 TROUBLESHOOTING.....	3
8.0 PROVISION OF SPARES.....	3
8.1 SOURCE OF SPARE PARTS.....	3
8.2 RECOMMENDED SPARE PARTS LISTS	3
9.0 IN SERVICE SUPPORT.....	3
10.0 GUARANTEES/LIMITATION OF LIABILITY.....	4

This product can not be modified without the written approval of Tronair, Inc. Any modifications done without written approval voids all warranties and releases Tronair, Inc., its suppliers, distributors, employees, or financial institutions from any liability from consequences that may occur. Only Tronair OEM replacement parts shall be used.

1.0 PRODUCT INFORMATION

1.1 DESCRIPTION

This fuel sample unit is designed to collect fuel samples from aviation equipment and has the following features:

- 4.05 in (10.3 cm) diameter collection opening
- #2 Pozidriv bit
- 4 mm hex bit

1.2 MODEL & SERIAL NUMBER

Reference nameplate on unit

1.3 MANUFACTURER

TRONAIR, Inc.
1 Air Cargo Pkwy East
Swanton, Ohio 43558 USA

Telephone: (419) 866-6301 or 800-426-6301
Fax: (419) 867-0634
E-mail: sales@tronair.com
Website: www.tronair.com

1.4 USAGE

The purpose of the Fuel Sample Unit is to collect fuel samples for Embraer Lineage, E190, E195, E1 and E2 aircraft.

1.5 SPECIFICATIONS

Capacity 32 oz (1000 ml)
Height 14.43 in (36.7 cm)
Diameter 5.12 in (13.0 cm)

2.0 SAFETY INFORMATION

This product does not fall under any of the European Community marking directives and cannot carry the CE mark.

2.1 USAGE AND SAFETY INFORMATION

To ensure safe operations please read the following statements and understand their meaning. Also refer to your equipment manufacturer's manual for other important safety information. This manual contains safety precautions which are explained below. Please read carefully.



WARNING!

Warning is used to indicate the presence of a hazard that can cause **severe personal injury, death, and/or substantial property damage** if the Warning Notice is ignored.



CAUTION!

Caution is used to indicate the presence of a hazard, which will or can cause **minor personal injury or property damage** if the Caution Notice is ignored.

2.1 PERSONAL PROTECTION EQUIPMENT

Due to the fluids involved, the use of personal protective equipment is required while using this equipment. Refer to applicable Safety Data Sheets.



WARNING!

Fuel sample units are designed to sample jet fuel which is highly flammable. Take proper care to prevent accidental ignition of fuel.

3.0 TRAINING

3.1 TRAINING REQUIREMENTS

The employer of the operator is responsible for providing a training program sufficient for the safe operation of the unit.

3.2 TRAINING PROGRAM

The employer provided operator training program should cover safety procedures concerning use of the unit in and around the intended aircraft at the intended aircraft servicing location.

3.3 OPERATOR TRAINING

The operator training should provide the required training for safe operation of the unit.

NOTE: Maintenance and Trouble Shooting are to be performed by a skilled and trained technician.

4.0 PRE-USE CHECKS

Refer to the Parts List and Illustration to identify and insure all parts are present.

- Generally, check over unit to ensure the tightness of all nuts, connectors and fittings
- Ensure proper installation of appropriate driver bit

5.0 OPERATION

1. Wear rubber gloves and safety goggles
2. Place the draining device below the drain valve
3. Ensure the draining device pin is aligned to the drain valve axis.
4. Use the draining device to open the drain valve by slowly pushing the stem halfway into the valve

NOTE:

- **If you push the stem halfway, fuel will flow continuously. After the desired amount of fuel is removed it is not necessary to rotate the drain valve stem to close the drain valve. Remove the stem and the existing spring action will close the drain valve.**
 - **If you accidentally push the stem full travel into the hard stop the drain valve may remain in the open position even if you stop pushing the draining device against it. In that event it will be necessary for you to turn the stem 30° (maximum) clockwise.**
5. Drain the tank until fuel going into the container has no water
 6. Pull back the draining device to close the drain valve

NOTE: If the drain valve does not close properly, with the aid of the draining device, slightly pus the stem and turn it 30° (maximum) clockwise.



CAUTION!

Before putting the draining device aside ensure the drain valve is closed. If you do not obey this precaution contamination of the environment can occur.

7. Ensure fuel has stopped flowing then remove the draining device from below the drain valve

NOTE: If fuel should continue to leak replace the seat o-ring.

8. Examine the collected fuel for contamination, especially at the fuel/water interface
 - a. Ensure the fuel is free from contamination
 - b. If you see water in the fuel continue to drain the tank until all water is removed
 - c. If presence of sediments or sludge in the fuel is observed, complete the Inspection of Microorganisms in the Tanks



WARNING!

Fuel sample units are designed to sample jet fuel which is highly flammable. Take proper care to prevent accidental ignition of fuel.



CAUTION!

When filling Fuel Sample Unit use proper safety precautions to avoid getting fuel on skin or in the eyes.



CAUTION!

Do not smoke or use open flame while using the Fuel Sample Unit.

6.0 PACKAGING AND STORAGE

Clean sampler as required and store in a clean, dry location.

7.0 TROUBLESHOOTING

TROUBLE	PROBABLE CAUSE	ACTION
No fuel goes into the bottle	Blockage in tube and/or cup	Inspect tube and cup for blockage and remove it
	5/32" ball driver is broken	Inspect 5/32" ball driver, Replace if damaged
	Drain valve not pushed in all the way or faulty	Insure 5/32" ball driver is properly inserted into drain valve and push inward until fuel comes out
Fuel leaks from cup at end of tube assembly	Damaged cup. Adhesive may be cracked	Check for damage and replace cup
Fuel leaks from fittings and/or cap on bottle	Fittings and/or cap are not tightened properly	Properly tighten fittings and/or cap
Fuel leaks from bottle	Bottle is damaged	Check for damage and replace bottle

8.0 PROVISION OF SPARES

8.1 SOURCE OF SPARE PARTS

Spare parts may be obtained from the manufacturer:

TRONAIR , Inc.	Telephone: (419) 866-6301 or 800-426-6301
1 Air Cargo Pkwy East	Fax: (419) 867-0634
Swanton, Ohio 43558 USA	E-mail: sales@tronair.com
	Website: www.tronair.com



For Spare Parts, Operations & Service Manuals or Service Needs:
Scan the QR code or visit Tronair.com/aftermarket

8.2 RECOMMENDED SPARE PARTS LISTS

Reference the following page for Replacement Parts and Kits available.

9.0 IN SERVICE SUPPORT

Contact Tronair, Inc. for technical services and information. See Section 1.3 – Manufacturer.

10.0 GUARANTEES/LIMITATION OF LIABILITY

Tronair products are warranted to be free of manufacturing or material defects for a period of one year after shipment to the original customer. This is solely limited to the repair or replacement of defective components. This warranty does not cover the following items:

- a) Parts required for normal maintenance
- b) Parts covered by a component manufacturers warranty
- c) Replacement parts have a 90-day warranty from date of shipment

If you have a problem that may require service, contact Tronair immediately. Do not attempt to repair or disassemble a product without first contacting Tronair, any action may affect warranty coverage. When you contact Tronair be prepared to provide the following information:

- a) Product Model Number
- b) Product Serial Number
- c) Description of the problem

If warranty coverage is approved, either replacement parts will be sent or the product will have to be returned to Tronair for repairs. If the product is to be returned, a Return Material Authorization (RMA) number will be issued for reference purposes on any shipping documents. Failure to obtain a RMA in advance of returning an item will result in a service fee. A decision on the extent of warranty coverage on returned products is reserved pending inspection at Tronair. Any shipments to Tronair must be shipped freight prepaid. Freight costs on shipments to customers will be paid by Tronair on any warranty claims only. Any unauthorized modification of the Tronair products or use of the Tronair products in violation of cautions and warnings in any manual (including updates) or safety bulletins published or delivered by Tronair will immediately void any warranty, express or implied.

The obligations of Tronair expressly stated herein are in lieu of all other warranties or conditions expressed or implied. **Any unauthorized modification of the Tronair products or use of the Tronair products in violations of cautions and warnings in any manual (including updates) or safety bulletins published or delivered by Tronair will immediately void any warranty, express or implied and Tronair disclaims any and all liability for injury (WITHOUT LIMITATION and including DEATH), loss or damage arising from or relating to such misuse.**

Parts List

When ordering Replacement Parts/Kits, please specify Model and Serial Number of your Unit.

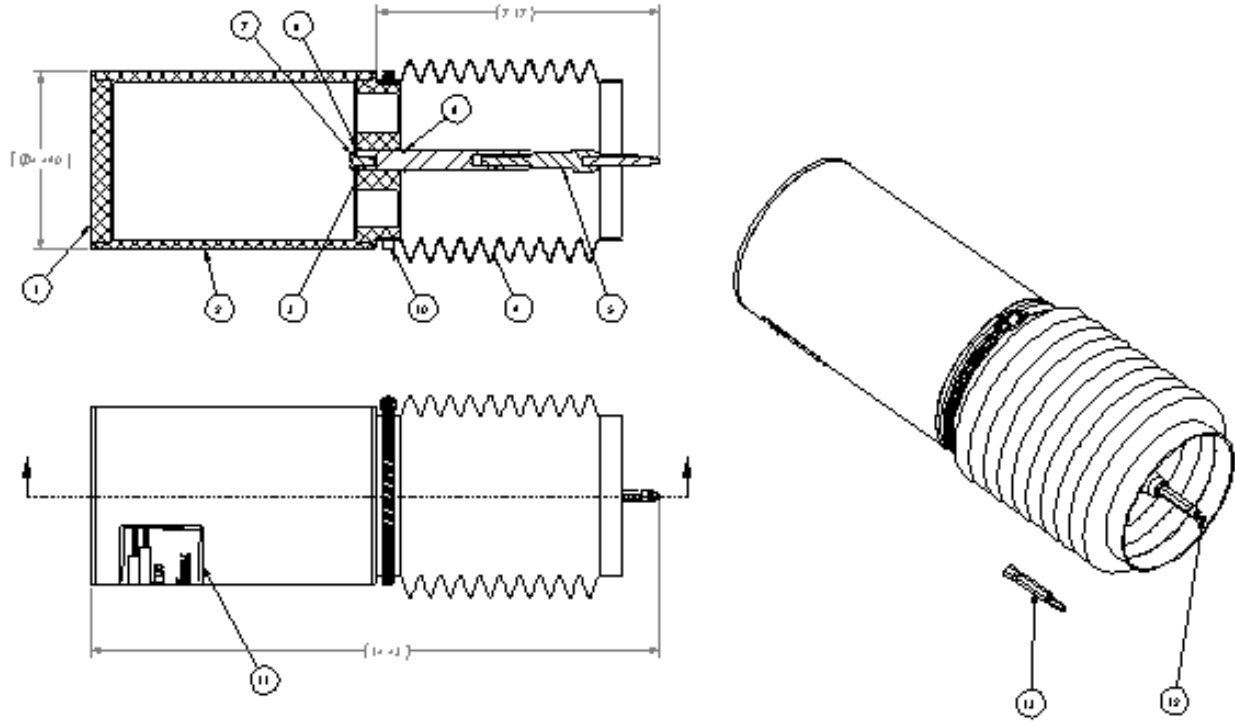

Item	Part Number	Description	Qty
1	R-2982	Base, Fuel Sample Collector	1
2	TR-2402	Tube, Fuel Sample Collector	1
3	R-2983	Plate, Fuel Drain	1
4	Z-8771	Weldment, Screwdriver Shaft	1
5	G-1250-1050N	Flatwasher, ¼ Narrow	1
6	G-1154-105204	Screw, ¼ - 20 SOC HD CAP	1
7	G-1392-50-H	Ring, External Retaining	1
8	H-3850	Bellow, Nitrile	1
9	H-1426-16	Clamp, #64 Hose	1
10	H-3851	Bit, Pozidriv #2	1
11	V-1003	Label, Serial Number	1
12	H-3852	Bit, Hex 4 mm	1
N/S	G-1250-1050N	Flatwasher, 1/4 Narrow	1