

**Model: 08-0130-4000  
PW-530A & PW-545A  
Engine Sling**



04/2007 – Rev. 03



**TABLE OF CONTENTS**

	<b><u>PAGE</u></b>
<b>1.0 PRODUCT INFORMATION .....</b>	<b>1</b>
1.1 DESCRIPTION.....	1
1.2 MODEL & SERIAL NUMBER.....	1
1.3 MANUFACTURER .....	1
<b>2.0 TRAINING .....</b>	<b>1</b>
2.1 TRAINING REQUIREMENTS .....	1
2.2 TRAINING PROGRAM .....	1
2.3 OPERATOR TRAINING.....	1
<b>3.0 ENGINE SLING USAGE INSTRUCTIONS .....</b>	<b>2</b>
<b>4.0 INSPECTION/MAINTENANCE .....</b>	<b>3</b>
4.1 TEST PROCEDURE .....	3
<b>5.0 PROVISION OF SPARES.....</b>	<b>4</b>
5.1 SOURCE OF SPARE PARTS.....	4
5.2 RECOMMENDED SPARE PARTS LISTS .....	4
<b>6.0 IN SERVICE SUPPORT .....</b>	<b>4</b>
<b>7.0 GUARANTEES/LIMITATION OF LIABILITY .....</b>	<b>4</b>
<b>8.0 APPENDICES .....</b>	<b>4</b>

This product can not be modified without the written approval of Tronair, Inc. Any modifications done without written approval voids all warranties and releases Tronair, Inc., its suppliers, distributors, employees, or financial institutions from any liability from consequences that may occur. Only Tronair OEM replacement parts shall be used.

**1.0 PRODUCT INFORMATION****1.1 DESCRIPTION**

The engine sling is designed to support the Pratt & Whitney PW-530A and PW-545A engine. Always follow the engine manufacturer's instructions for engine handling.

**1.2 MODEL & SERIAL NUMBER**

Reference nameplate on unit

**1.3 MANUFACTURER**

**TRONAIR**, Inc.  
1740 Eber Road  
Holland, Ohio 43528-9794 USA

Telephone: (419) 866-6301 or 800-426-6301  
Fax: (419) 867-0634  
E-mail: sales@tronair.com  
Website: www.tronair.com

**2.0 TRAINING****2.1 TRAINING REQUIREMENTS**

The employer of the operator is responsible for providing a training program sufficient for the safe operation of the unit.

**2.2 TRAINING PROGRAM**

The employer provided operator training program should cover safety procedures concerning use of the unit in and around the intended aircraft at the intended aircraft servicing location.

**2.3 OPERATOR TRAINING**

The operator training should provide the required training for safe operation of the unit.

**NOTE: Maintenance and Trouble Shooting are to be performed by a skilled and trained technician.**

### 3.0 ENGINE SLING USAGE INSTRUCTIONS

This engine sling incorporates an adjustable modular clevis block and slide blocks for fast and easy handling. The sling consists of a lightweight aluminum "I" beam, aluminum block clevises, and steel connection straps. Engine sling setup for PW-530A and PW-545A. See **Figure 1**.

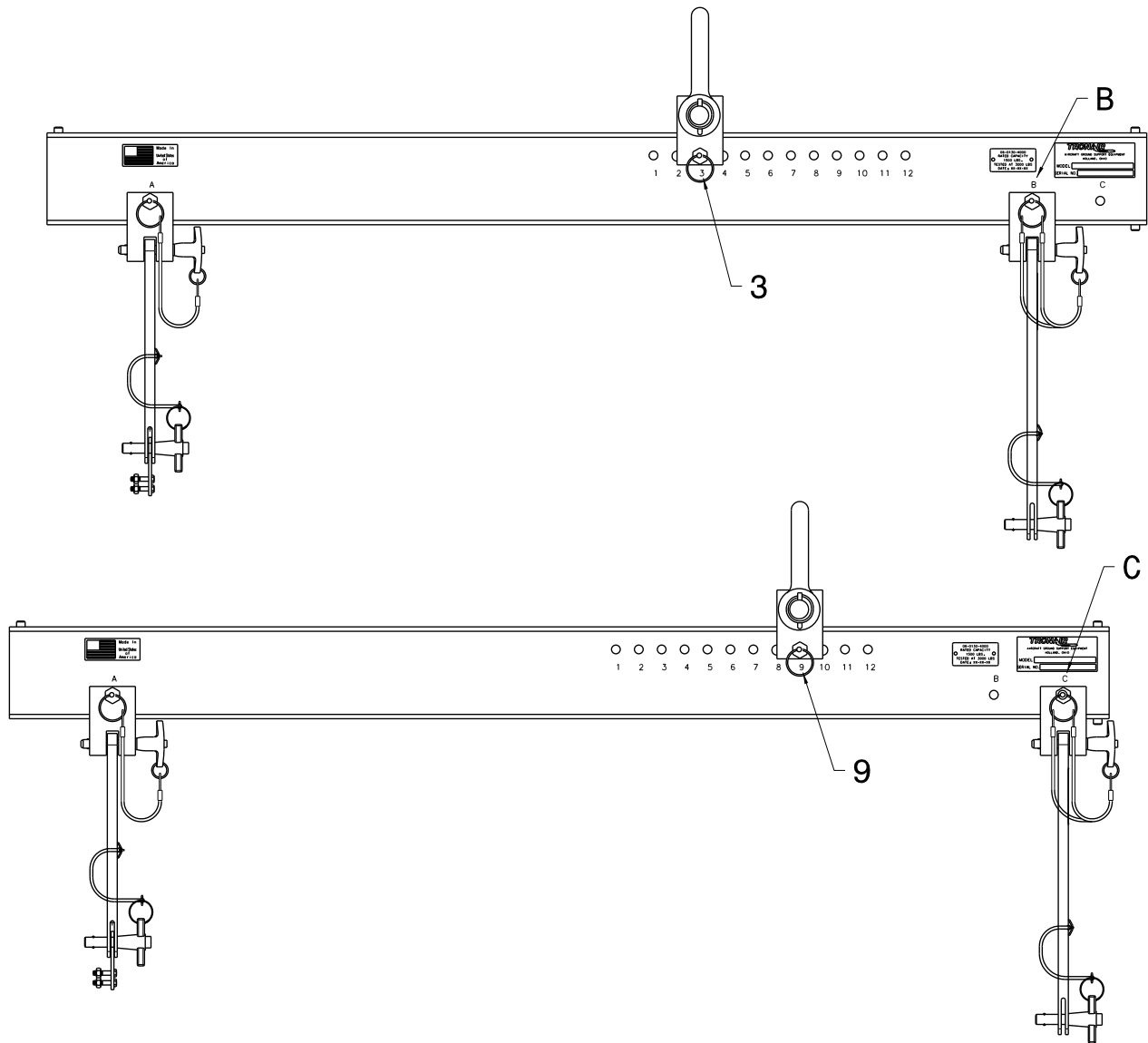

A rear lift plate is included with the engine sling. This will be removed and assembled to the engine with provided fasteners. See **Figure 2 – Page 2**.

**3.0 ENGINE SLING USAGE INSTRUCTIONS** *(continued)*

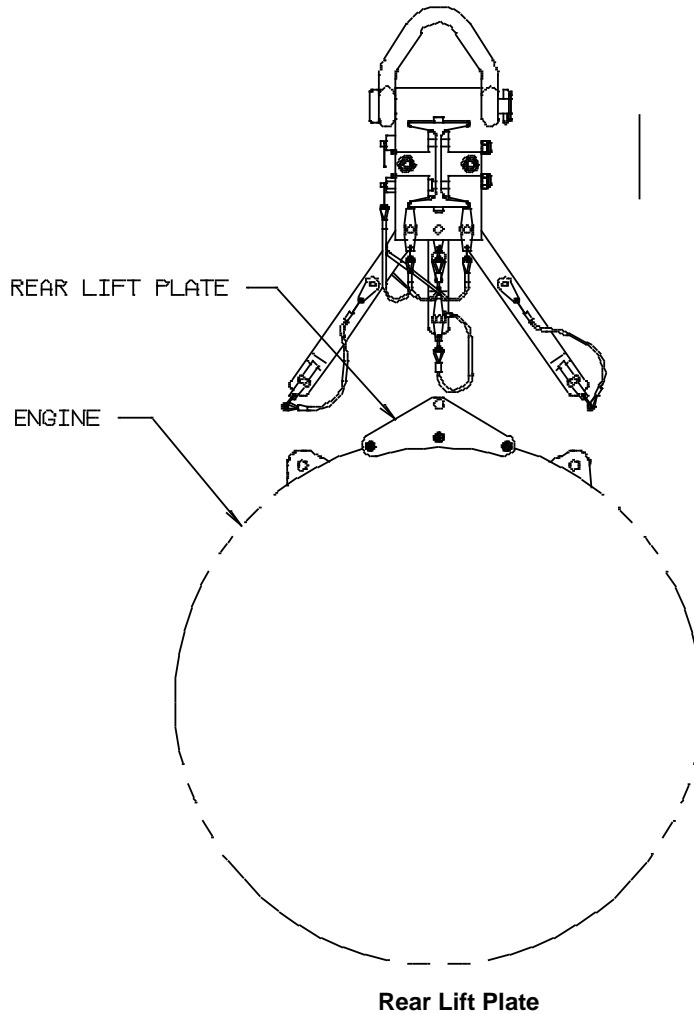

**4.0 INSPECTION/MAINTENANCE**

SERVICE	INTERVAL	
Normal	Yearly	Inspect equipment at site of use. Operation with various weights within the rated load limit, or uniform loads less than 65 percent of rated load.
Heavy	Semi-Annual	Inspect equipment at site of use unless external conditions indicate that disassembly should be done to permit detailed inspection. Operation within the rated load limit that exceeds normal service.
Severe	Quarterly	Inspect equipment at site of use unless external conditions indicate that disassembly should be done to permit detailed inspection. Operation at normal or heavy service under abnormal operating conditions.
Special/ Infrequent	As recommended by a qualified person before the first such use and as directed by the qualified person for any subsequent uses	

**It is recommended to send Equipment to Manufacturer or Authorized Service Center for Recertification.**

Rated load at engine sling lift hole: 1500 lbs.

The rated capacity shall not be more than 80 percent of the maximum load sustained during the test. Test loads shall not be more than 125 percent of the rated capacity unless otherwise recommended by the manufacturer. Test weights shall be accurate to within -5 percent, +0 percent of stipulated values.

**4.1 TEST PROCEDURE**

1. Load test sling to 125% of rated load
2. Hold for one (1) minute.
3. Remove the sling from the test weight and inspect the entire sling for broken welds, elongated holes, or any other signs of failure.)

## 5.0 PROVISION OF SPARES

### 5.1 SOURCE OF SPARE PARTS

Spare parts may be obtained from the manufacturer:

**TRONAIR**, Inc.

1740 Eber Road

Holland, Ohio 43528-9794 USA

Telephone: (419) 866-6301 or 800-426-6301

Fax: (419) 867-0634

E-mail: sales@tronair.com

Website: www.tronair.com

### 5.2 RECOMMENDED SPARE PARTS LISTS

Reference the following page(s) for Replacement Parts and Kits available.

## 6.0 IN SERVICE SUPPORT

Contact Tronair, Inc. for technical services and information. See Section 1.3 – Manufacturer.

## 7.0 GUARANTEES/LIMITATION OF LIABILITY

Tronair products are warranted to be free of manufacturing or material defects for a period of one year after shipment to the original customer. This is solely limited to the repair or replacement of defective components. This warranty does not cover the following items:

- a) Parts required for normal maintenance
- b) Parts covered by a component manufacturers warranty
- c) Replacement parts have a 90-day warranty from date of shipment

If you have a problem that may require service, contact Tronair immediately. Do not attempt to repair or disassemble a product without first contacting Tronair, any action may affect warranty coverage. When you contact Tronair be prepared to provide the following information:

- a) Product Model Number
- b) Product Serial Number
- c) Description of the problem

If warranty coverage is approved, either replacement parts will be sent or the product will have to be returned to Tronair for repairs. If the product is to be returned, a Return Material Authorization (RMA) number will be issued for reference purposes on any shipping documents. Failure to obtain a RMA in advance of returning an item will result in a service fee. A decision on the extent of warranty coverage on returned products is reserved pending inspection at Tronair. Any shipments to Tronair must be shipped freight prepaid. Freight costs on shipments to customers will be paid by Tronair on any warranty claims only. Any unauthorized modification of the Tronair products or use of the Tronair products in violation of cautions and warnings in any manual (including updates) or safety bulletins published or delivered by Tronair will immediately void any warranty, express or implied.

The obligations of Tronair expressly stated herein are in lieu of all other warranties or conditions expressed or implied. **Any unauthorized modification of the Tronair products or use of the Tronair products in violations of cautions and warnings in any manual (including updates) or safety bulletins published or delivered by Tronair will immediately void any warranty, express or implied and Tronair disclaims any and all liability for injury (WITHOUT LIMITATION and including DEATH), loss or damage arising from or relating to such misuse.**

## 8.0 APPENDICES

APPENDIX I Declaration of Conformity

## Parts List

When ordering replacement parts/kits, please specify model, serial number and color of your unit.

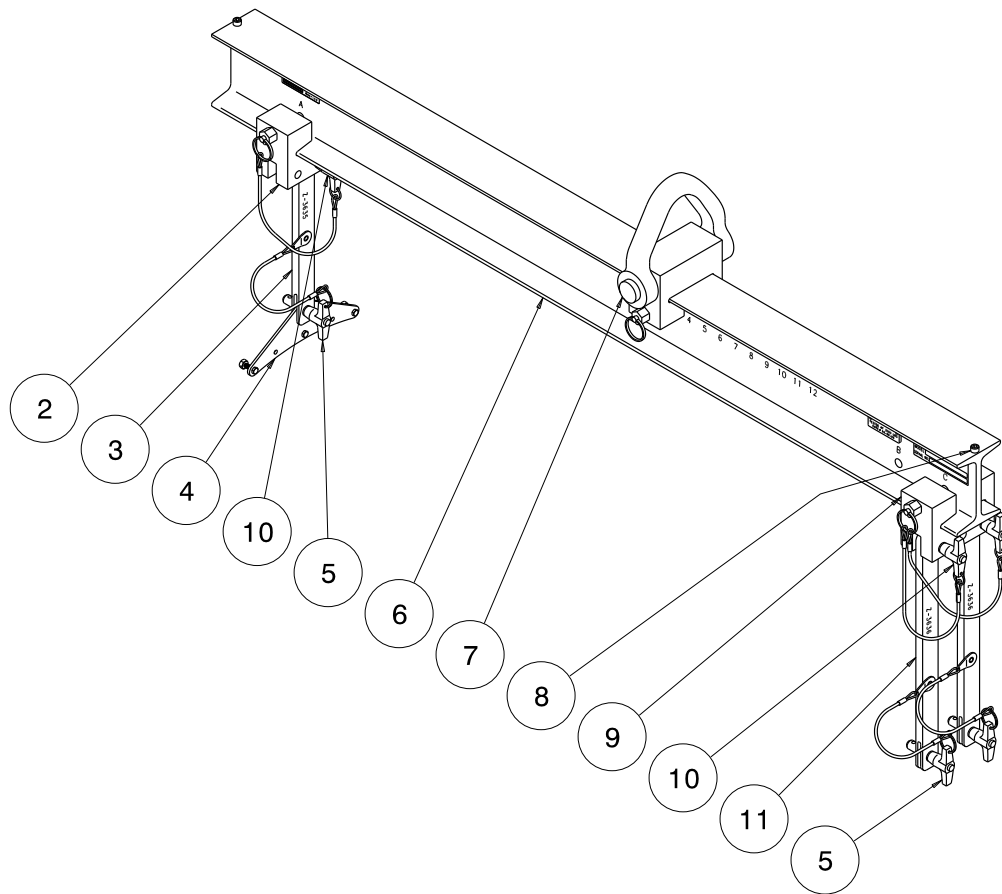

Item	Part Number	Description	Qty
2	Z-3640	Assembly, Slide Block (includes item 10)	1
3	Z-3635	Assembly, Rear Strap (includes item 5)	1
6		Main Support Beam ( <i>Not Sold Separately</i> )	1
7	Z-2863	Assembly, Clevis Block	1
8	G-1151-105203	Screw, Socket Head Cap, 1/4-20 x 3/8" long	2
9	Z-2864	Assembly, Slide Block (includes item 10)	1
11	Z-3636	Assembly, Front Strap (includes item 5)	2
4	<b>K-2684</b>	<b>Kit, Replacement Rear Lift Plate; consists of:</b>	
	J-2619	Plate, Rear Lift	1
	G-1110-3-7A	Bolt, Hex Head #10-32 AN	3
	G-1202-1035	Stopnut #10-32 Elastic	3
	G-1255-04	Washer, #10 AN	3
5	<b>K-2375</b>	<b>Kit, Replacement Ball Lok-T Pin; consists of:</b>	
	G-1310-0710	Pin, Ball-Lok-T, 7/16 diameter x 1" long	1
	G-1351-04	Rivet, 1/8 Open-End Steel	1
	H-1026*07.0	Assembly, Lanyard	1
10	<b>K-2376</b>	<b>Kit, Replacement Ball Lok-T Pin; consists of:</b>	
	G-1310-0620	Pin, Ball Lok-T 3/8 diameter x 2" long	1
	G-1351-04	Rivet, 1/8 Open-End Steel	1
	H-1026*07.0	Assembly, Lanyard	1





## **APPENDIX I**

### **Declaration of Conformity**





## DECLARATION of CONFORMITY

The design, development and manufacture is in accordance with European Community guidelines

08-0130-4000  
Engine Sling  
PW530A & PW545A

Relevant draft complied with by the machinery:  
EN ISO 12100-1

Relevant standards complied with by the machinery:  
EN ISO 12100-1  
EN 1915-1:2001 (5.20)

Identification of person empowered to sign on behalf of the Manufacturer:

A handwritten signature in black ink that reads "Patrick Finch". The signature is written in a cursive style and is positioned above a horizontal line.

Quality Assurance Representative