



# OPERATION & SERVICE MANUAL

**Model: 08-0139-4000  
PW306B Engine Sling**



06/2005 - Rev. 01

REVISION  
OR  
01

DATE  
03/2002  
06/2005

TEXT AFFECTED  
Original release  
pg 2 Modified Items 2 and 4  
Modified quantities for items 6, 7 & 8  
Pg 3 Modified illustration

**TABLE OF CONTENTS**

	<b><u>PAGE</u></b>
<b>1.0 PRODUCT INFORMATION .....</b>	<b>1</b>
1.1 DESCRIPTION.....	1
1.2 MODEL & SERIAL NUMBER.....	1
1.3 MANUFACTURER.....	1
1.4 SPECIFICATIONS .....	1
<b>2.0 SAFETY .....</b>	<b>1</b>
<b>3.0 TRAINING .....</b>	<b>1</b>
3.1 TRAINING REQUIREMENTS .....	1
3.2 TRAINING PROGRAM .....	1
3.3 OPERATOR TRAINING.....	1
<b>4.0 ENGINE HANGING INSTRUCTIONS.....</b>	<b>2</b>
<b>5.0 INSPECTION .....</b>	<b>2</b>
5.1 LOAD TEST .....	2
5.2 TEST PROCEDURE .....	2
<b>6.0 PROVISION OF SPARES.....</b>	<b>2</b>
6.1 SPARE PARTS .....	2
6.2 PARTS LISTS & ILLUSTRATIONS.....	2
<b>7.0 IN-SERVICE SUPPORT.....</b>	<b>2</b>
<b>8.0 GUARANTEES/LIMITATION OF LIABILITY .....</b>	<b>3</b>

This product can not be modified without the written approval of Tronair, Inc. Any modifications done without written approval voids all warranties and releases Tronair, Inc., its suppliers, distributors, employees, or financial institutions from any liability from consequences that may occur. Only Tronair OEM replacement parts shall be used.

## 1.0 PRODUCT INFORMATION

### 1.1 DESCRIPTION

The Tronair 08-0139-4000 Engine Sling is designed for use on the Dornier 328 Jet equipped with the Pratt-Whitney PW306B engine. Always follow manufacturer's instructions for proper engine handling.

### 1.2 MODEL & SERIAL NUMBER

Reference nameplate on unit

### 1.3 MANUFACTURER

**TRONAIR**, Inc.  
1 Air Cargo Pkwy East  
Swanton, Ohio 43558

Telephone: (419) 866-6301 or 800-426-6301  
E-mail: sales@tronair.com  
Website: www.tronair.com

### 1.4 SPECIFICATIONS

- Sling weight: 130 lbs (59 kg) *approximate*
- Capacity: 1,900 lbs (862 kg)
- Length: 45 in (114 cm)
- Width: 40 in (102 cm)
- Height: 61-3/8 in (156 cm) *approximate from top of bar to engine*
- Finish: Tronair Blue Powder Coat and Zinc Chromate with clear overcoat

## 2.0 SAFETY

Safety instructions specifically pertaining to this unit appear throughout this manual highlighted by the signal words **WARNING** and **CAUTION** which identify different levels of hazard.



### WARNING!

Denote practices which if not carefully followed, could result in **SERIOUS** personal injury or death, and/or minor personal injury or damage to this equipment.

- **NEVER** exceed rated load or lift a load not intended for this sling.
- **NEVER** use sling if any damage or excessive wear is found.
- **NEVER** lift suspended loads over personnel.
- **NEVER** make any alterations or modifications to sling.
- **ALWAYS** stay clear of suspended loads.

### CAUTION!



Ensure engine is balanced on sling. If engine is unbalanced, check that the orientation of sling is correct. In the event of an unbalanced condition, loss of control and/or damage may occur to the engine along with injury to operator.

- **NEVER** use sling to lift personnel.
- **NEVER** leave suspended loads unattended.
- **NEVER** remove or obscure warning labels.
- **DO NOT** use sling until you have read and understood this manual.
- **NEVER** lift loads higher than necessary.

## 3.0 TRAINING

### 3.1 TRAINING REQUIREMENTS

The employer of the operator is responsible for providing a training program sufficient for the safe operation of the unit.

### 3.2 TRAINING PROGRAM

The employer provided operator training program should cover safety procedures concerning use of the unit in and around the intended aircraft at the intended aircraft servicing location.

### 3.3 OPERATOR TRAINING

The operator training should provide the required training for safe operation of the unit.

**NOTE: Maintenance and Trouble Shooting are to be performed by a skilled and trained technician.**

#### 4.0 ENGINE HANGING INSTRUCTIONS

1. Assemble sling on crane (or equivalent) as shown in Parts List.
2. Attach to engine sling mounts.
3. Before lifting engine, ensure all ball-lok pins and shackles are secure.

#### 5.0 INSPECTION

SERVICE	INTERVAL	
Normal	Yearly	Inspect equipment at site of use. Operation with various weights within the rated load limit, or uniform loads less than 65 percent of rated load.
Heavy	Semi-Annual	Inspect equipment at site of use unless external conditions indicate that disassembly should be done to permit detailed inspection. Operation within the rated load limit that exceeds normal service.
Severe	Quarterly	Inspect equipment at site of use unless external conditions indicate that disassembly should be done to permit detailed inspection. Operation at normal or heavy service under abnormal operating conditions.
Special/ Infrequent	As recommended by a qualified person before the first such use and as directed by the qualified person for any subsequent uses	

This sling needs to be inspected per the following:

##### Every Lift Inspection (performed visually by operator):

- Missing parts (pins, fasteners, labels, etc).
- Operation of all ball-lok pins & shackles.
- Inspect sling components for any signs of material deformation, cracks, or excessive wear.

##### Frequent & Periodic Inspections (performed by designated personnel):

- Visual (performed monthly): same as Every Lift Inspection
- Record (Semi-annually):
  - Loose bolts and fasteners
  - Cracked or excessively worn straps, bars & plates
  - Excessive wear at hoist points and load support clevis & pins.

#### 5.1 LOAD TEST

**It is recommended to send Equipment to Manufacturer or Authorized Service Center for Recertification.**

Rated load at engine sling lift hole: 1900 lbs.

The rated capacity shall not be more than 80 percent of the maximum load sustained during the test. Test loads shall not be more than 125 percent of the rated capacity unless otherwise recommended by the manufacturer. Test weights shall be accurate to within -5 percent, +0 percent of stipulated values.

#### 5.2 TEST PROCEDURE

1. Load test sling to 125% of rated load
2. Hold for one (1) minute.
3. Remove the sling from the test weight and inspect the entire sling for broken welds, elongated holes, or any other signs of failure.)

#### 6.0 PROVISION OF SPARES

##### 6.1 SPARE PARTS

Spare parts may be obtained from the manufacturer:

**TRONAIR, Inc.** Telephone: (419) 866-6301 or 800-426-6301  
 1 Air Cargo Pkwy East E-mail: sales@tronair.com  
 Swanton, Ohio 43558 Website: www.tronair.com

##### 6.2 PARTS LISTS & ILLUSTRATIONS

Reference the following page for Replacement Parts and Kits available.

#### 7.0 IN-SERVICE SUPPORT

Contact Tronair for technical services and information.

**8.0 GUARANTEES/LIMITATION OF LIABILITY**

Tronair products are warranted to be free of manufacturing or material defects for a period of one year after shipment to the original customer. This is solely limited to the repair or replacement of defective components. This warranty does not cover the following items:

- a) Parts required for normal maintenance
- b) Parts covered by a component manufacturers warranty
- c) Replacement parts have a 90-day warranty from date of shipment

If you have a problem that may require service, contact Tronair immediately. Do not attempt to repair or disassemble a product without first contacting Tronair, any action may affect warranty coverage. When you contact Tronair be prepared to provide the following information:

- a) Product Model Number
- b) Product Serial Number
- c) Description of the problem

If warranty coverage is approved, either replacement parts will be sent or the product will have to be returned to Tronair for repairs. If the product is to be returned, a Return Material Authorization (RMA) number will be issued for reference purposes on any shipping documents. Failure to obtain a RMA in advance of returning an item will result in a service fee. A decision on the extent of warranty coverage on returned products is reserved pending inspection at Tronair. Any shipments to Tronair must be shipped freight prepaid. Freight costs on shipments to customers will be paid by Tronair on any warranty claims only. Any unauthorized modification of the Tronair products or use of the Tronair products in violation of cautions and warnings in any manual (including updates) or safety bulletins published or delivered by Tronair will immediately void any warranty, express or implied.

The obligations of Tronair expressly stated herein are in lieu of all other warranties or conditions expressed or implied. **Any unauthorized modification of the Tronair products or use of the Tronair products in violations of cautions and warnings in any manual (including updates) or safety bulletins published or delivered by Tronair will immediately void any warranty, express or implied and Tronair disclaims any and all liability for injury (WITHOUT LIMITATION and including DEATH), loss or damage arising from or relating to such misuse.**

## Parts List

When ordering replacement parts/kits, please specify model, serial number and color of your unit.

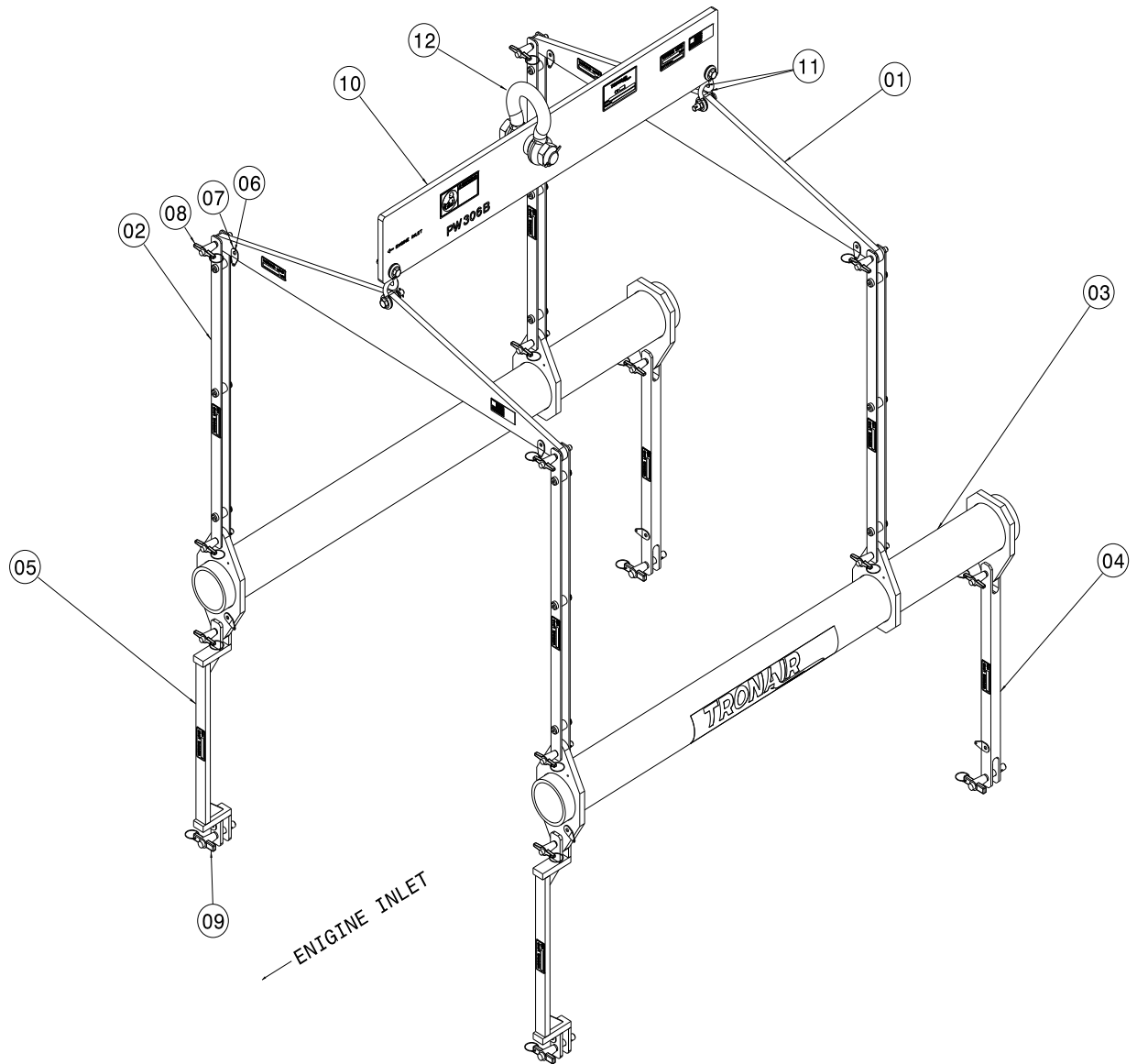

Item	Part Number	Description	Qty
1	J-3088-01	Plate, Sling Mount	2
2	Z-6129	Assembly, Extension Arm Strap	4
3	Z-4628-01	Weldment, Spreader Bar	2
4	J-3760	Strap, Rear Arm	2
5	Z-4629	Weldment, Front Arm	2
6	G-1351-04	Rivet, 1/8 Open-End Steel	12
7	H-1026*07.0	Assembly, Lanyard	12
8	G-1310-0613	Pin, 3/8" diameter x 1-1/4" long, Ball Lok-T	8
9	G-1310-0715	Pin, 7/16" diameter x 1-1/2" long, Ball Lok-T	4
10	J-3406	Bar, Sling (PW306B Engine)	1
11	H-2652-03	Shackle, 5/16	4
12	H-2652-09	Shackle, 7/8	1

**Note:** Lanyards not shown for clarity.







## **APPENDIX I**

### **Declaration of Conformity**





## DECLARATION of CONFORMITY

The design, development and manufacture is in accordance with European Community guidelines

08-0139-4000  
Engine Sling  
PW306B

Relevant draft complied with by the machinery:  
EN ISO 12100-1

Relevant standards complied with by the machinery:  
EN ISO 12100-1  
EN 1915-1:2001 (5.20)

Identification of person empowered to sign on behalf of the Manufacturer:

A handwritten signature in cursive script, reading "Patrick Finch". The signature is written in black ink and is positioned above a horizontal line that spans the width of the signature area.

Quality Assurance Representative