

**Model: 08-0144-4000  
 PW308A & PW308C Engine Sling**



This product can not be modified without the written approval of Tronair, Inc. Any modifications done without written approval voids all warranties and releases Tronair, Inc., its suppliers, distributors, employees, or financial institutions from any liability from consequences that may occur. Only Tronair OEM replacement parts shall be used.

**1.0 DESCRIPTION**

The Tronair 08-0144-4000 Engine Sling is designed for the Pratt-Whitney PW308A and PW308C engines. Always follow manufacturer's instructions for proper engine handling.

**2.0 SPECIFICATIONS**

Sling weight.....65 lbs (29.5 kg) approximate  
 Capacity .....1,900 lbs (862 kg)  
 Length .....37 in (94 cm)  
 Width .....30 in (76 cm) Z-6098  
 Height.....22 in (56 cm) top of bar to engine  
 Finish.....Zinc chromate with clear overcoat

**3.0 SAFETY**

Safety instructions specifically pertaining to this unit appear throughout this manual highlighted by the signal words **WARNING** and **CAUTION** which identify different levels of hazard.

**WARNINGS!**



Denote practices which if not carefully followed, could result in **SERIOUS** personal injury or death, and/or minor personal injury or damage to this equipment.

- **NEVER** exceed rated load or lift a load not intended for this sling.
- **NEVER** use sling if any damage or excessive wear is found.
- **NEVER** lift suspended loads over personnel.
- **NEVER** make any alterations or modifications to sling.
- **ALWAYS** stay clear of suspended loads.

**CAUTIONS!**



Ensure engine is balanced on sling. If engine is unbalanced, check that the orientation of sling is correct. In the event of an unbalanced condition, loss of control and/or damage may occur to the engine along with injury to operator.

- **NEVER** use sling to lift personnel.
- **NEVER** leave suspended loads unattended.
- **NEVER** remove or obscure warning labels.
- **DO NOT** use sling until you have read and understood this manual.
- **NEVER** lift loads higher than necessary.

**4.0 ENGINE HANGING INSTRUCTIONS**

1. Attach sling to engine as shown in Parts List - Page 3.
2. Place lift clevis (Item 4) in desired hole (stamped on bar) (see Chart below) and rear strap assembly (Items 5 or 6) positioned as depicted in the label above holes A and B (see Parts List – Page 3)
3. Before lifting engine, ensure all ball-loc pins, shackles and/or nuts are secure.

| Lift Clevis Position | Engine configuration                     |
|----------------------|--|
| 1                    | Engine with Inlet Cowl only              |
| 2                    | Engine only                              |
| 3                    | Engine with Inlet Cowl & Thrust Reverser |
| 4                    | Engine with Thrust Reverser              |

## 5.0 INSPECTION

This sling needs to be inspected per the following:

1. Every Lift Inspection (performed visually by operator):
  - a. Missing parts (pins, fasteners, labels, etc).
  - b. Operation of all ball-lok pins & shackles.
  - c. Inspect sling components for any signs of material deformation, cracks, or excessive wear.
2. Frequent & Periodic Inspections (performed by designated personnel):
  - a. Visual (performed monthly): same as 6.1 Every Lift Inspection
  - b. Record (Semi-Annually):
    - Loose bolts and fasteners
    - Cracked or excessively worn straps, bars & plates
    - Excessive wear at hoist points and load support clevis & pins.

## 6.0 LOAD TEST

This sling was proof tested to 200% (3,800 lbs/1,724 kg) of rated load; test certification is included with documentation. If it is found necessary to load test sling, use a fixed fixture and load cell (due to sling arms not being centered on sling bar which may result in an unbalanced load condition). Load test to at least 125% (2,375 lbs/1,077 kg) of rated load, or return to Tronair.

## 7.0 GUARANTEES/LIMITATION OF LIABILITY

Tronair products are warranted to be free of manufacturing or material defects for a period of one year after shipment to the original customer. This is solely limited to the repair or replacement of defective components. This warranty does not cover the following items:

- a) Parts required for normal maintenance
- b) Parts covered by a component manufacturers warranty
- c) Replacement parts have a 90-day warranty from date of shipment

If you have a problem that may require service, contact Tronair immediately. Do not attempt to repair or disassemble a product without first contacting Tronair, any action may affect warranty coverage. When you contact Tronair be prepared to provide the following information:

- a) Product Model Number
- b) Product Serial Number
- c) Description of the problem

If warranty coverage is approved, either replacement parts will be sent or the product will have to be returned to Tronair for repairs. If the product is to be returned, a Return Material Authorization (RMA) number will be issued for reference purposes on any shipping documents. Failure to obtain a RMA in advance of returning an item will result in a service fee. A decision on the extent of warranty coverage on returned products is reserved pending inspection at Tronair. Any shipments to Tronair must be shipped freight prepaid. Freight costs on shipments to customers will be paid by Tronair on any warranty claims only. Any unauthorized modification of the Tronair products or use of the Tronair products in violation of cautions and warnings in any manual (including updates) or safety bulletins published or delivered by Tronair will immediately void any warranty, express or implied.

The obligations of Tronair expressly stated herein are in lieu of all other warranties or conditions expressed or implied. **Any unauthorized modification of the Tronair products or use of the Tronair products in violations of cautions and warnings in any manual (including updates) or safety bulletins published or delivered by Tronair will immediately void any warranty, express or implied and Tronair disclaims any and all liability for injury (WITHOUT LIMITATION and including DEATH), loss or damage arising from or relating to such misuse.**

## Parts List

When ordering Replacement Parts/Kits, please specify Model, Color and Serial Number of your Unit

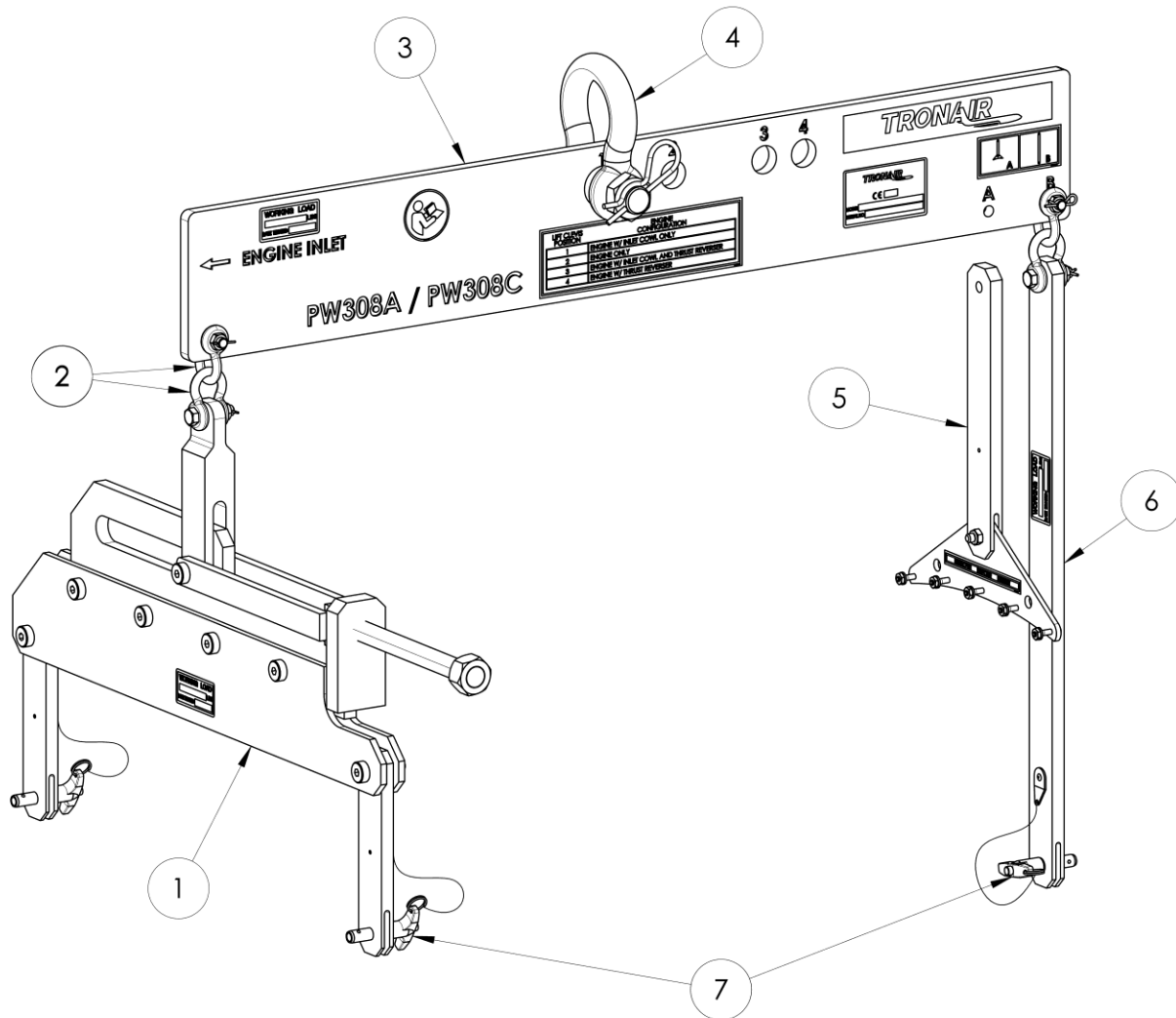

Note: Lanyards not shown for clarity

| Item | Part Number   | Description   | Qty |
|------|---------------|---|-----|
| 1    | Z-6098        | Assembly, Front Mount                               | 1   |
| 2    | H-2652-03     | Shackle, 5/16                                       | 4   |
| 3    | J-3720        | Bar, PW308A Sling                                   | 1   |
| 4    | H-2652-09     | Shackle, 7/8  | 1   |
| 5    | Z-6107        | Assembly, Flange Lift                               | 1   |
| 6    | Z-6111        | Assembly, Rear Strap                                | 1   |
| 7    | <b>K-2375</b> | <b>Kit, Ball Lok-T Pin Replacement; consists of</b> |     |
|      | H-1026*07.0   | Assembly, Lanyard                                   | 1   |
|      | G-1310-0710   | Pin, Ball Lok-T, 7/16" diameter x 1.0" Grip         | 1   |
|      | G-1351-04     | Rivet, 1/8 Open-End Steel                           | 1   |

Note: Items 1, 5 & 6 include ball-loc pins (Item 7)



## DECLARATION of CONFORMITY

The design, development and manufacture is in accordance with European Community guidelines

08-0144-4000  
Engine Sling  
PW308A

Relevant draft complied with by the machinery:  
EN ISO 12100-1

Relevant standards complied with by the machinery:  
EN ISO 12100-1  
EN 1915-1:2001 (5.20)

Identification of person empowered to sign on behalf of the Manufacturer:

A handwritten signature in cursive script that reads "Patrick Finch". The signature is written in black ink and is positioned above a solid horizontal line.

Quality Assurance Representative



The Tronair Family of Ground Support Equipment  
and cloud based EBis GSE Fleet Management



Cloud Based  
Fleet Management

The premier global supplier of ground support equipment



# The Tronair Family of GSE Product Lines

UNPARALLELED RANGE OF PRODUCTS FOR BUSINESS, COMMERCIAL AND MILITARY AIRCRAFT

## **LIFTING & SHORING (ATA-7)**

Hydraulic Tripod Jacks  
Axle Jacks  
Jack Test Equipment  
Stabilizing Stands & Alarms  
Aircraft Recovery Dollies

## **LEVELING & WEIGHING (ATA-8)**

Aircraft Weigh Equipment

## **TOWING AND TAXIING (ATA-9)**

Towbar Systems  
Tow Vehicles & Tractors

## **PARKING & MOORING (ATA-10)**

Chocks & Covers

## **SERVICING (ATA-12)**

Multi-Purpose Carts  
Hydraulic & Engine Oil Servicing  
& Test Equipment  
Lavatory Servicing Carts  
Potable Water Transport Carts  
Oxygen & Nitrogen Carts  
Oxygen & Nitrogen Boosters

## **AIR CONDITIONING (ATA-21)**

Air Conditioning Equipment  
Coolant System Fill/Drain Carts  
Cabin Pressurization Test Units

## **ELECTRICAL (ATA-24)**

Ground Power Units  
Battery Charger/Analyzer

## **FUEL (ATA-28)**

Fuel Transfer Cart  
Fuel Tools

## **HYDRAULIC POWER (ATA-29)**

Hydraulic Power Units  
Ram Air Turbine (RAT)  
Hydraulic Coupling Hose Adaptors

## **ICE & RAIN PROTECTION (ATA-30)**

Deicer Carts

## **AIRCRAFT TOOLING**

Designed to your Specifications

## **LANDING GEAR (ATA-32)**

Beadbreakers  
Dollies - Wheel & Brake  
Service Tools  
Strut Service Carts  
Regulators, Adaptors,  
Connectors & Gauges

## **FUSELAGE (ATA-53)**

Lifts, Cranes & Hoists  
Maintenance Platforms  
Access Stands  
Docking Systems

## **PROPELLERS (ATA-61)**

Propeller Stands/Slings/Tools

## **POWER PLANT (ATA-71)**

Engine Compressor Washers  
Engine Hoists, Slings & Stands

## **CLOUD BASED FLEET MGT.**

Manage your Repair Station,  
Multi Location Jet Center or  
Small Operation



[www.tronair.com](http://www.tronair.com)

[www.columbusjack.com](http://www.columbusjack.com) | [www.daeind.com](http://www.daeind.com) | [www.datcomedia.com](http://www.datcomedia.com) | [www.eagletugs.com](http://www.eagletugs.com) | [www.malabar.com](http://www.malabar.com)

Sales Offices: USA • Asia/China • Australia/New Zealand/Singapore • Europe/Middle East/Africa

Tronair, Inc. • 1 Air Cargo Pkwy East • Swanton, OH 43558, USA  
Phone: 419-866-6301 | Toll Free: 1-800-426-6301 | Email: [sales@tronair.com](mailto:sales@tronair.com)