



# OPERATION & SERVICE MANUAL

## Model: 08-0145C4000 PW615 F Engine Sling



10/2008 – Rev. 02

This product can not be modified without the written approval of Tronair, Inc. Any modifications done without written approval voids all warranties and releases Tronair, Inc., its suppliers, distributors, employees, or financial institutions from any liability from consequences that may occur. Only Tronair OEM replacement parts shall be used.

**INSPECTION/MAINTENANCE**

SERVICE	INTERVAL	
Normal	Yearly	Inspect equipment at site of use. Operation with various weights within the rated load limit, or uniform loads less than 65 percent of rated load.
Heavy	Semi-Annual	Inspect equipment at site of use unless external conditions indicate that disassembly should be done to permit detailed inspection. Operation within the rated load limit that exceeds normal service.
Severe	Quarterly	Inspect equipment at site of use unless external conditions indicate that disassembly should be done to permit detailed inspection. Operation at normal or heavy service under abnormal operating conditions.
Special/ Infrequent	As recommended by a qualified person before the first such use and as directed by the qualified person for any subsequent uses	

**It is recommended to send Equipment to Manufacturer or Authorized Service Center for Recertification.**

Rated load at engine sling lift hole: 450 lbs.

The rated capacity shall not be more than 80 percent of the maximum load sustained during the test. Test loads shall not be more than 125 percent of the rated capacity unless otherwise recommended by the manufacturer. Test weights shall be accurate to within -5 percent, +0 percent of stipulated values.

**TEST PROCEDURE**

1. Load test sling to 125% of rated load
2. Hold for one (1) minute.
3. Remove the sling from the test weight and inspect the entire sling for broken welds, elongated holes, or any other signs of failure.)

**GUARANTEES/LIMITATION OF LIABILITY**

Tronair products are warranted to be free of manufacturing or material defects for a period of one year after shipment to the original customer. This is solely limited to the repair or replacement of defective components. This warranty does not cover the following items:

- a) Parts required for normal maintenance
- b) Parts covered by a component manufacturer's warranty
- c) Replacement parts have a 90-day warranty from date of shipment

If you have a problem that may require service, contact Tronair immediately. Do not attempt to repair or disassemble a product without first contacting Tronair, any action may affect warranty coverage. When you contact Tronair be prepared to provide the following information:

- a) Product Model Number
- b) Product Serial Number
- c) Description of the problem

If warranty coverage is approved, either replacement parts will be sent or the product will have to be returned to Tronair for repairs. If the product is to be returned, a Return Material Authorization (RMA) number will be issued for reference purposes on any shipping documents. Failure to obtain a RMA in advance of returning an item will result in a service fee. A decision on the extent of warranty coverage on returned products is reserved pending inspection at Tronair. Any shipments to Tronair must be shipped freight prepaid. Freight costs on shipments to customers will be paid by Tronair on any warranty claims only. Any unauthorized modification of the Tronair products or use of the Tronair products in violation of cautions and warnings in any manual (including updates) or safety bulletins published or delivered by Tronair will immediately void any warranty, express or implied.

The obligations of Tronair expressly stated herein are in lieu of all other warranties or conditions expressed or implied. **Any unauthorized modification of the Tronair products or use of the Tronair products in violations of cautions and warnings in any manual (including updates) or safety bulletins published or delivered by Tronair will immediately void any warranty, express or implied and Tronair disclaims any and all liability for injury (WITHOUT LIMITATION and including DEATH), loss or damage arising from or relating to such misuse.**

## Parts List

When ordering Replacement Parts/Kits, please specify Model, Color and Serial Number of your Unit

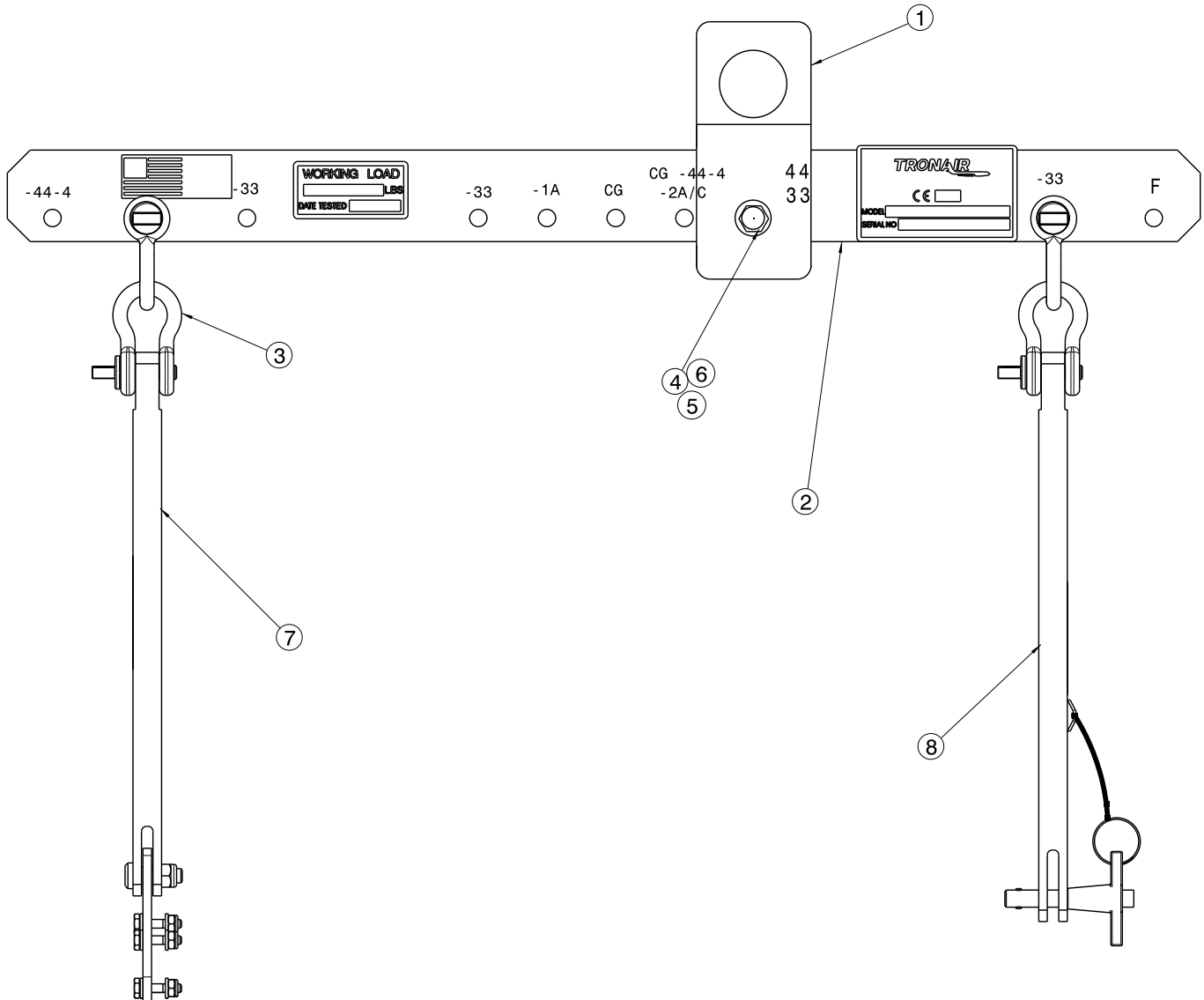

Item	Part Number	Description	Qty
1	Z-2494	Sling, Clevis	1
2	J-2022	Bar, Sling	1
3	H-1508-02	Shackle	4
4	G-1100-107514	Bolt, Hex Head, Grade 5, 3/8-24 x 1 1/2 long	1
5	G-1250-1070N	Flatwasher, 3/8 Narrow	2
6	G-1202-1075	Stopnut, 3/8-24 Elastic	1
	<b>K-4000</b>	<b>Kit, Front Strap Replacement; consists of:</b>	
3	H-1508-02	Shackle	2
7	Z-6200	Weldment, Strap	1
11	Z-6203	Weldment, Strap	1



## **APPENDIX I**

### **Declaration of Conformity**



## DECLARATION of CONFORMITY

The design, development and manufacture is in accordance with European Community guidelines

PW615 F  
ENGINE SLING

Relevant provisions complied with by the machinery:  
EN 292-2:1991/A1:1995 (4.3.2)

Relevant standards complied with by the machinery:  
EN 292-2:1991/A1:1995 (4.1.2.3)  
EN 1915-1:2001 (5.20)

Identification of person empowered to sign on behalf of the Manufacturer:

A handwritten signature in cursive script that reads "Patrick Finch". The signature is written in black ink and is positioned above a solid horizontal line.

Quality Assurance Representative