

**Model: 08-2023-0010
Engine Work Stand**

05/1998 – Rev. 03

REVISION
03

DATE
05/1998

TEXT AFFECTED
Revision

TABLE OF CONTENTS

PAGE

1.0	PRODUCT INFORMATION	1
1.1	DESCRIPTION.....	1
1.2	MODEL & SERIAL NUMBER.....	1
1.3	MANUFACTURER	1
1.4	USAGE	1
1.5	SPECIFICATIONS	1
2.0	TRAINING	1
2.1	TRAINING REQUIREMENTS	1
2.2	TRAINING PROGRAM	1
2.3	OPERATOR TRAINING.....	1
3.0	ASSEMBLY INSTRUCTIONS.....	2
3.1	GENERAL INFORMATION.....	2
3.2	ASSEMBLY STEPS	2
3.3	PRE-USE CHECKS	3
4.0	OPERATION.....	3
5.0	TROUBLESHOOTING	3
6.0	MAINTENANCE.....	4
6.1	PERIODIC INSPECTION.....	4
6.2	LOAD TEST	4
7.0	GUARANTEES/LIMITATION OF LIABILITY	5

This product can not be modified without the written approval of Tronair, Inc. Any modifications done without written approval voids all warranties and releases Tronair, Inc., its suppliers, distributors, employees, or financial institutions from any liability from consequences that may occur. Only Tronair OEM replacement parts shall be used.

1.0 PRODUCT INFORMATION

1.1 DESCRIPTION

The Tronair Engine Work Stand incorporates the following quality features:

- Heavy steel construction
- Easily maneuverable
- Can be fixed into static position with floor locks
- Oil pan to capture excess fluid
- Rotatable into eight positions. Position may be fixed with locking pin.

1.2 MODEL & SERIAL NUMBER

Reference nameplate on unit

1.3 MANUFACTURER

TRONAIR, Inc.
1 Air Cargo Pkwy East
Swanton, Ohio 43558 USA

Telephone: (419) 866-6301 or 800-426-6301
Fax: (419) 867-0634
E-mail: sales@tronair.com
Website: www.tronair.com

1.4 USAGE

The purpose of this stand equipped with proper cradle assembly is to allow mechanics easy access to any part of engine system during engine inspection and maintenance procedures. **See Engine Application Chart for specific cradle assemblies required for each engine.**

ENGINE APPLICATION CHART

Engine	Cradle Assembly
Allison 250 C18 & 20	K-2108
Allison 250 C28 & 30	K-2108
Garrett TPE-331	K-2110
Lycoming LTS-101	K-2111

1.5 SPECIFICATIONS

Weight: 169 lbs
Length: 33 inches
Width: 39-5/8 inches
Height: 44 inches

2.0 TRAINING

2.1 TRAINING REQUIREMENTS

The employer of the operator is responsible for providing a training program sufficient for the safe operation of the unit.

2.2 TRAINING PROGRAM

The employer provided operator training program should cover safety procedures concerning use of the unit in and around the intended aircraft at the intended aircraft servicing location.

2.3 OPERATOR TRAINING

The operator training should provide the required training for safe operation of the unit.

NOTE: Maintenance and Trouble Shooting are to be performed by a skilled and trained technician.

3.0 ASSEMBLY INSTRUCTIONS

3.1 GENERAL INFORMATION

This product should be assembled and/or repaired using good workmanship practices and proper tools. Bolts and elastic stopnuts should be tightened to a torque not to exceed industry standards for grade '5' bolts. The 3/8-24 bolts should be tightened to 35 ft-lbs.

3.2 ASSEMBLY STEPS

1. Refer to the parts list and engine application chart.
2. Attach post/cradle assembly to frame with 3/8-24 x 3" hex head bolts. Tighten top bolts first.

Engine Stand Cradle Installation Procedure:

1. Remove the flanged bearing unit from upright post (see **Figure 1**).
2. Remove pillow block assembly from opposite upright post (see **Figure 1**).

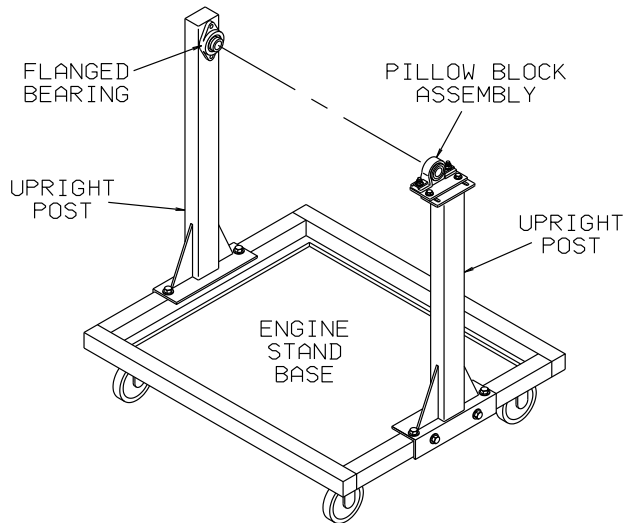

FIGURE 1

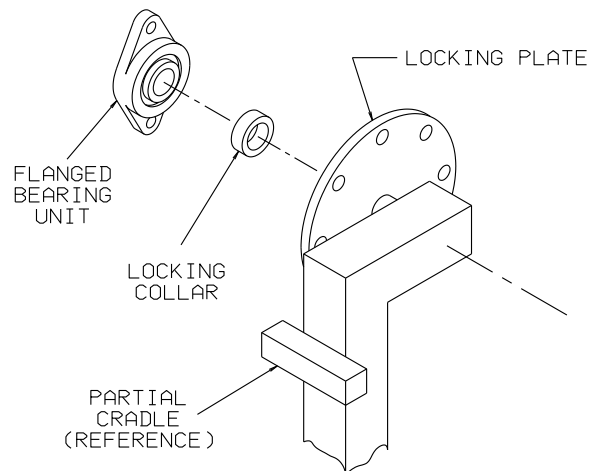

FIGURE 2

3. Slide the flanged bearing unit onto the cradle shaft near the locking plate, making sure that the locking collar is on first as shown in **Figure 2**. Do not hammer the bearing unit; the bearing should slide easily onto the cradle shaft. If it is necessary to apply force in mounting, check cradle and or bearing for nicks or burrs. Replace as necessary. Repeat on opposite cradle shaft with pillow block assembly.
4. Position both bearings so that the end of the shafts protrude completely through the bearing races, to ensure maximum engagement of both bearings (see **Figures 3 & 4**).

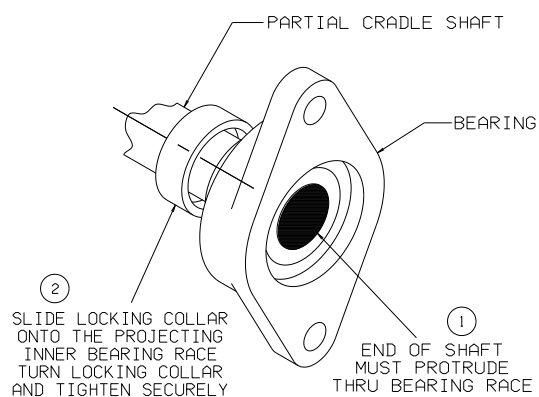

FIGURE 3

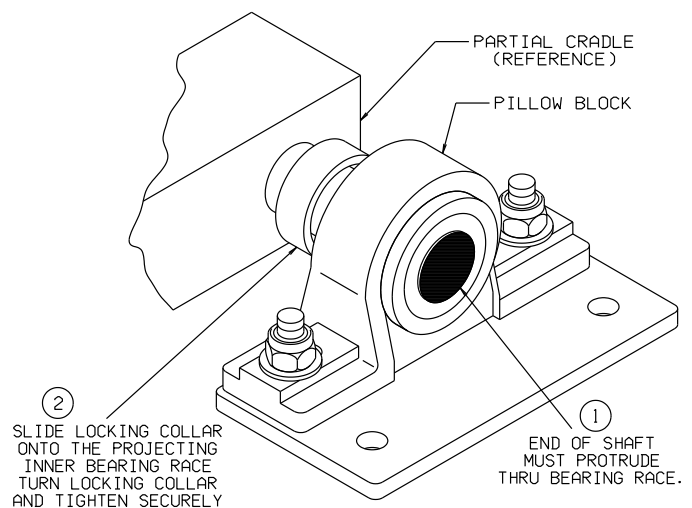

FIGURE 4

5. With the bearings in position on the shaft, slide the locking collars onto the projecting inner races of the bearings. Tighten the collars securely using a spanner wrench. Tighten the setscrews securely against the shaft (see **Figures 3 & 4**).

3.2 Assembly Steps continued on following page.

3.2 ASSEMBLY STEPS (continued)

6. Install the cradle/bearing assembly onto the engine stand base by temporarily resting the pillow block onto the upright post as shown in **Figure 5**. Secure flange bearing end of cradle assembly to opposite upright post using two (2) bolts, nuts and washers provided with the flange bearing unit.
7. Secure the pillow block end of cradle assembly to slotted plate on upright post of base using two (2) bolts, nuts and washers provided (see **Figure 5**).
8. Tighten flange bearing nuts and bolts first, then tighten pillow block nuts and bolts. Verify operation of rotating cradle mechanism. Engine Stand Cradle Installation is complete.

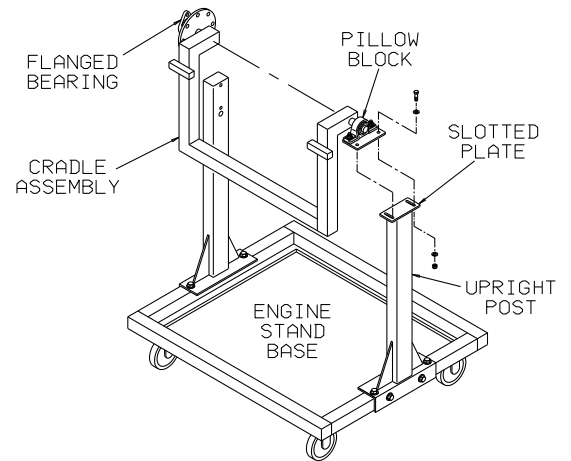

FIGURE 5

3.3 PRE-USE CHECKS

Refer to the parts list and illustration attached to identify and assure that all parts are present.

- Generally check over unit to assure the tightness of all nuts and bolts.

4.0 OPERATION

1. Attach appropriate sling (not included with stand) to engine and remove from aircraft according to manufacturer's instructions.
2. Lower engine into engine work stand with engine center of gravity over cradle shafts.
3. Remove hoist from work area.
4. Actuate floor locks.
5. Engine may be rotated into desired position and fixed, using ball lock pin.
6. To remove engine – reverse the above operational steps.

5.0 TROUBLESHOOTING

If rotating mechanism works with difficulty, check for the following causes:

1. Engine installed backwards.
2. Lack of lubrication.

ENGINE APPLICATION CHART

Engine	Cradle Assembly
Allison 250 C18 & 20	K-2108
Allison 250 C28 & 30	K-2108
Garrett TPE-331	K-2110
Lycoming LTS-101	K-2111

6.0 MAINTENANCE

6.1 PERIODIC INSPECTION

A qualified inspector shall perform a complete inspection at the following intervals

SERVICE	INTERVAL	
Normal	Yearly	Inspect equipment at site of use. Operation with various weights within the rated load limit, or uniform loads less than 65 percent of rated load.
Heavy	Semi-Annual	Inspect equipment at site of use unless external conditions indicate that disassembly should be done to permit detailed inspection. Operation within the rated load limit that exceeds normal service.
Severe	Quarterly	Inspect equipment at site of use unless external conditions indicate that disassembly should be done to permit detailed inspection. Operation at normal or heavy service under abnormal operating conditions.
Special/ Infrequent	As recommended by a qualified person before the first such use and as directed by the qualified person for any subsequent uses	

1. Before each use visually inspect unit to ensure all components are present and functional
 - All bolts & nuts are secure
 - All casters & locks are operational
 - No bent or, broken components



WARNING!

Ensure stand components are free of damage and or excessive wear. Never use stand if any component is bent or broken

2. Periodically:
 - Lubricate swivel caster bearing race with multi-purpose grease.
 - Lubricate gear box assembly per manufacturer's recommendations.
3. Annually:
 - a. Safely perform load test

6.2 LOAD TEST

It is recommended to send Equipment to Manufacturer or Authorized Service Center for Recertification.

The rated capacity shall not be more than 80 percent of the maximum load sustained during the test. Test loads shall not be more than 125 percent of the rated capacity unless otherwise recommended by the manufacturer. Test weights shall be accurate to within -5 percent, +0 percent of stipulated values.

1. Overall visual inspection
2. Lubricate spindles and gear box
3. Inspect anti-rotation locking mechanism
4. Install test weight equivalent to 1000lbs
5. Rotate weight set 360 in both directions
6. Operation should be free of binding and/or catching during rotation
7. Remove load and visually inspect stand for any signs of wear or failure



7.0 GUARANTEES/LIMITATION OF LIABILITY

Tronair products are warranted to be free of manufacturing or material defects for a period of one year after shipment to the original customer. This is solely limited to the repair or replacement of defective components. This warranty does not cover the following items:

- a) Parts required for normal maintenance
- b) Parts covered by a component manufacturers warranty
- c) Replacement parts have a 90-day warranty from date of shipment

If you have a problem that may require service, contact Tronair immediately. Do not attempt to repair or disassemble a product without first contacting Tronair, any action may affect warranty coverage. When you contact Tronair be prepared to provide the following information:

- a) Product Model Number
- b) Product Serial Number
- c) Description of the problem

If warranty coverage is approved, either replacement parts will be sent or the product will have to be returned to Tronair for repairs. If the product is to be returned, a Return Material Authorization (RMA) number will be issued for reference purposes on any shipping documents. Failure to obtain a RMA in advance of returning an item will result in a service fee. A decision on the extent of warranty coverage on returned products is reserved pending inspection at Tronair. Any shipments to Tronair must be shipped freight prepaid. Freight costs on shipments to customers will be paid by Tronair on any warranty claims only. Any unauthorized modification of the Tronair products or use of the Tronair products in violation of cautions and warnings in any manual (including updates) or safety bulletins published or delivered by Tronair will immediately void any warranty, express or implied.

The obligations of Tronair expressly stated herein are in lieu of all other warranties or conditions expressed or implied. **Any unauthorized modification of the Tronair products or use of the Tronair products in violations of cautions and warnings in any manual (including updates) or safety bulletins published or delivered by Tronair will immediately void any warranty, express or implied and Tronair disclaims any and all liability for injury (WITHOUT LIMITATION and including DEATH), loss or damage arising from or relating to such misuse.**

This page left blank intentionally.

Parts List

When ordering replacement parts/kits, please specify model, serial number and color of your unit.

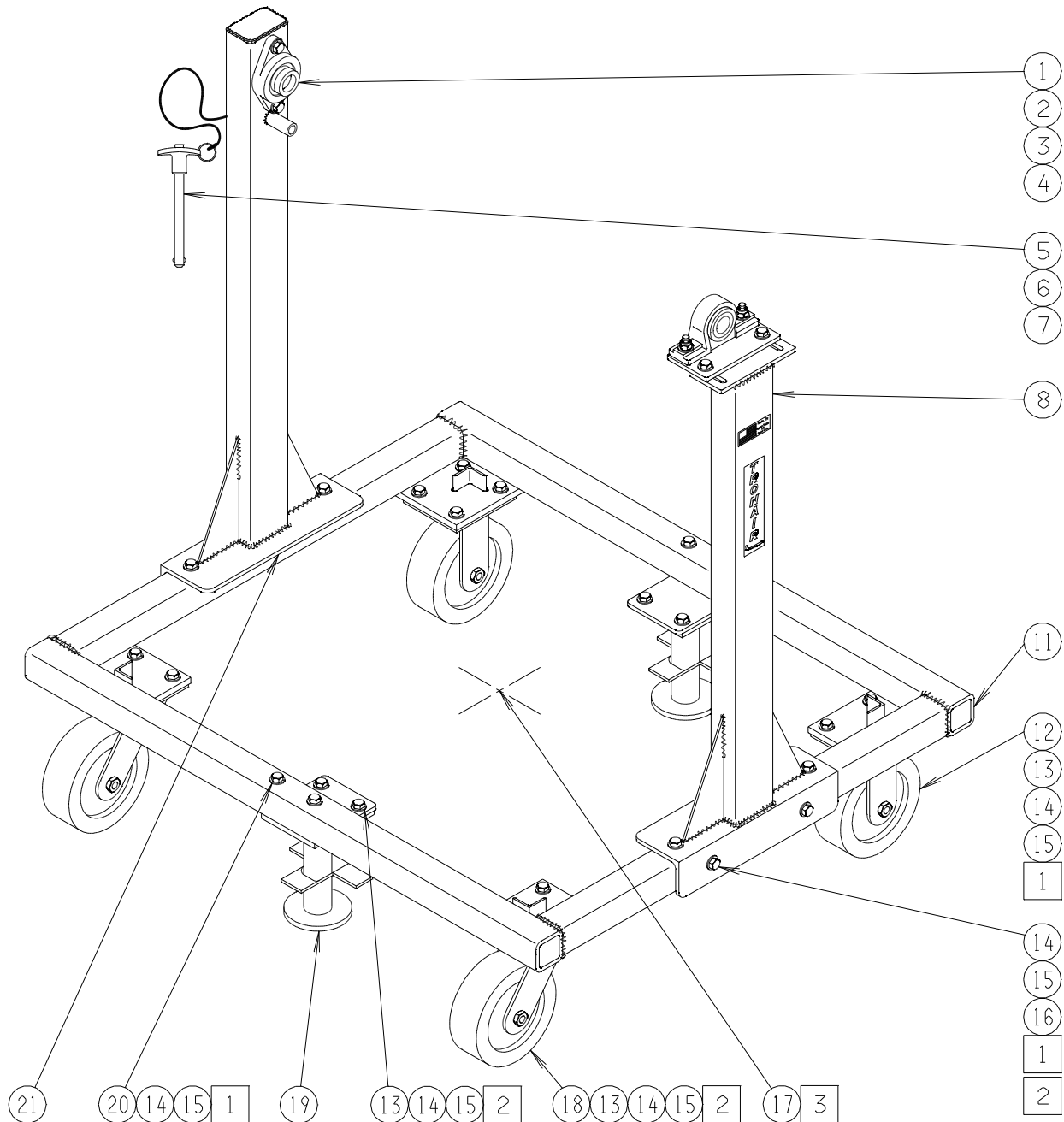

NOTES:

- One flatwasher washer is under both the bolt head and the stopnut.
- At assembly, tighten vertical (top) bolts first, then horizontal (side) bolts to ensure squareness of posts.
- Oil pan not shown for clarity.

Parts List

When ordering replacement parts/kits, please specify model, serial number and color of your unit.

Item	Part Number	Description	Qty
	K-2215	Kit, Post Assembly; consists of:	
8		Assembly, Post	1
9		Label, "Made In USA"	1
10		Label, "Tronair"	1
14		Flatwasher, 3/8 Narrow	8
15		Stopnut, 3/8-24 Elastic	4
16		Bolt, Hex Head, Grade 5, 3/8-24 x 3" long	4
	K-2923	Kit, Flange Bearing; consists of:	
1		Bearing, Flange	1
2		Bolt, Hex Head, Grade 5, 7/16-20 x 3" long	2
3		Washer, AN 7/16	2
4		Stopnut, 7/16-20 Elastic	2
	K-2924	Kit, Rigid Caster; consists of:	
12		Caster, Rigid	1
13		Bolt, Hex Head, Grade 5, 3/8-24 x 1 1/4" long	4
14		Flatwasher, 3/8 Narrow	4
15		Stopnut, 3/8-24 Elastic	4
	K-2925	Kit, Swivel Caster; consists of:	
13		Bolt, Hex Head, Grade 5, 3/8-24 x 1 1/4" long	4
14		Flatwasher, 3/8 Narrow	4
15		Stopnut, 3/8-24 Elastic	4
18		Caster, Swivel	1
	K-2926	Kit, Floor Lock; consists of:	
13		Bolt, Hex Head, Grade 5, 3/8-24 x 1 1/4" long	2
14		Flatwasher, 3/8 Narrow	4
15		Stopnut, 3/8-24 Elastic	4
19		Lock, Floor	1
20		Bolt, Hex Head, Grade 5, 3/8-24 x 3 1/4" long	2
	K-2927	Kit, Post Assembly; consists of:	
1		Bearing, Flange	1
2		Bolt, Hex Head, Grade 5, 7/16-20 x 3" long	2
3		Washer, AN 7/16	2
4		Stopnut, 7/16-20 Elastic	2
5		Pin, Ball Lok-T	1
6		Assembly, Lanyard, 12" long	1
7		Rivet, 1/8 Open-End Steel, 1/4" Grip	1
14		Flatwasher, 3/8 Narrow	8
15		Stopnut, 3/8-24 Elastic	4
16		Bolt, Hex Head, Grade 5, 3/8-24 x 3" long	4
21		Weldment, Post	1
	K-2928	Kit, Ball Lok-T Pin; consists of:	
5		Pin, Ball Lok-T	1
6		Assembly, Lanyard, 12" long	1
7		Rivet, 1/8 Open-End Steel, 1/4" Grip	1

Z-2658 – Pillow Block Assembly

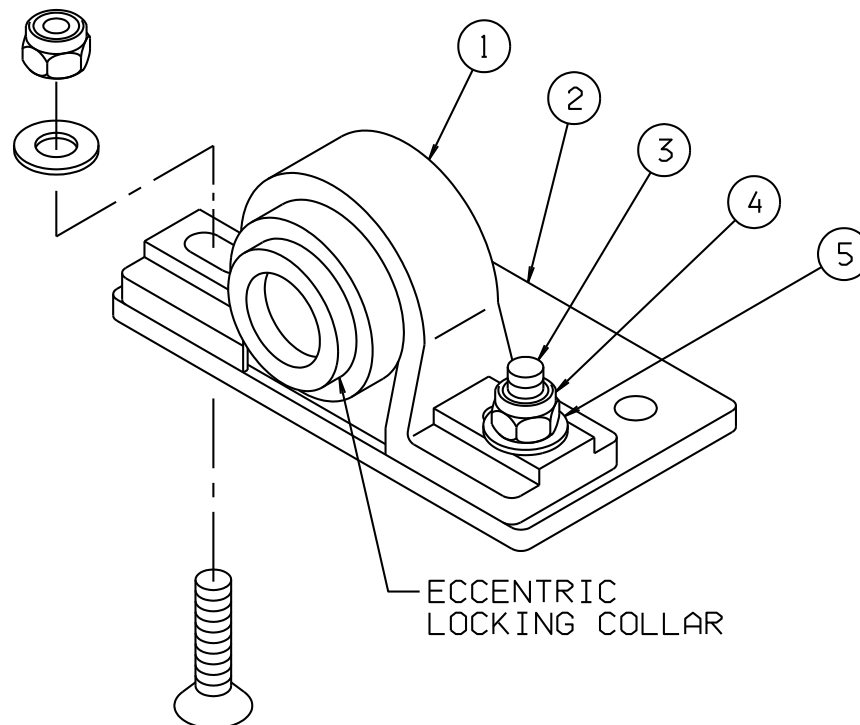

Item	Part Number	Description	Qty
1	H-1847	Pillow Block	1
2	J-2099-01	Plate	1
3	G-1152-107212	Screw, 3/8-16 x 1-1/4" long, Socket Flat Head Cap	2
4	G-1202-1070	Stopnut, 3/8-16 Elastic	2
5	G-1250-1070N	Flatwasher, 3/8 Narrow	2