

Model: 08-4054-0010
Engine Compressor Washer

11/2022 – Rev. 03

For Spare Parts, Operations & Service Manuals or Service Needs
Scan the QR code or visit Tronair.com/aftermarket



REVISION	DATE	TEXT AFFECTED
OR	10/2001	Original Release
01	10/2009	Modified 3.3 Fluid System, Parts List
02	07/2010	Revised engine
03	11/2022	Major revision

TABLE OF CONTENTS

	<u>PAGE</u>
1.0 PRODUCT INFORMATION	1
1.1 DESCRIPTION.....	1
2.0 SAFETY INFORMATION.....	1
2.1 USAGE AND SAFETY INFORMATION	1
3.0 TRAINING	1
3.1 TRAINING REQUIREMENTS	1
3.2 TRAINING PROGRAM	1
3.3 OPERATOR TRAINING.....	1
4.0 ASSEMBLY INSTRUCTIONS.....	2
4.1 GENERAL.....	2
4.2 ASSEMBLY.....	2
5.0 OPERATION.....	2
5.1 SAFETY	2
5.1.1 Cautions.....	2
5.2 ENGINE SYSTEM.....	2
5.3 FLUID SYSTEM.....	2
5.3.1 To Prime Pump	2
5.3.2 To Clean Pump Suction Strainer:.....	2
5.4 TRAILER SYSTEM	2
6.0 MAINTENANCE.....	3
6.1 ENGINE SYSTEM.....	3
6.2 FLUID SYSTEM.....	3
6.3 TRAILER SYSTEM	3
7.0 STORAGE.....	3
7.1 GENERAL.....	3
8.0 PROVISION OF SPARES.....	3
8.1 SOURCE OF SPARE PARTS.....	3
8.2 RECOMMENDED SPARE PARTS LISTS	3
9.0 IN SERVICE SUPPORT.....	3
10.0 GUARANTEES/LIMITATION OF LIABILITY	4
11.0 APPENDICIES	4

This product can not be modified without the written approval of Tronair, Inc. Any modifications done without written approval voids all warranties and releases Tronair, Inc., its suppliers, distributors, employees, or financial institutions from any liability from consequences that may occur. Only Tronair OEM replacement parts shall be used.

1.0 PRODUCT INFORMATION

1.1 DESCRIPTION

The Model 08-4054-0010 Engine Compressor Washer will spray decontamination or cleaning fluid as required for engine compressor rinsing and/or cleaning. Follow engine manufacturer's instructions for application techniques.

- Trailer mounted
- 200 gallon capacity tank
- 10 GPM pump powered by a 6.5 Horsepower gasoline engine.
- 30 foot hose

2.0 SAFETY INFORMATION

2.1 USAGE AND SAFETY INFORMATION

To insure safe operations please read the following statements and understand their meaning. Also refer to your equipment manufacturer's manual for other important safety information. This manual contains safety precautions which are explained below. Please read carefully.



WARNING!

Warning is used to indicate the presence of a hazard that can cause **severe personal injury, death, and/or substantial property damage** if the Warning Notice is ignored.



CAUTION!

Caution is used to indicate the presence of a hazard, which will or can cause **minor personal injury or property damage** if the Caution Notice is ignored.

3.0 TRAINING

3.1 TRAINING REQUIREMENTS

The employer of the operator is responsible for providing a training program sufficient for the safe operation of the unit.

3.2 TRAINING PROGRAM

The employer provided operator training program should cover safety procedures concerning use of the unit in and around the intended aircraft at the intended aircraft servicing location.

3.3 OPERATOR TRAINING

The operator training should provide the required training for safe operation of the unit.

NOTE: Maintenance and Trouble Shooting are to be performed by a skilled and trained technician.

4.0 ASSEMBLY INSTRUCTIONS

4.1 GENERAL

This product should be assembled and/or repaired as applicable, using good workmanship practices and proper tools. Bolts and elastic stopnuts should be tightened to a torque not to exceed standards for Grade '5' bolts.

Bolt Torque	
Size	Ft-lbs
5/16-24	20
3/8-24	35
1/2-20	85

SAE Classification
Grade 5



All replacement parts must be the same as or ec

Markings on top of bolt head indicate grade.

4.2 ASSEMBLY

This unit is shipped fully assembled and ready for your use. See **5.0 Operation** prior to starting engine.

5.0 OPERATION

5.1 SAFETY



WARNING!

High pressure sprays can cause serious bodily injury.

5.1.1 Cautions

1. ALWAYS grasp hose firmly before starting to spray. During operation, hold hose firmly and exercise care and caution in handling.
2. ALWAYS exercise care in towing trailer. When trailer is to be removed from towing vehicle, chock wheels of trailer prior to disconnecting.
3. NEVER put hand or fingers in front of hose end or point hose end at your body or at anyone else.
4. NEVER refuel gasoline tank while engine is running.
5. NEVER operate system if there are any leaks because high pressure leaks can cause bodily harm.
6. BE SURE to read operating instructions including those for both engine and pump prior to starting unit.
7. BE SURE to perform periodic cleaning, maintenance and parts replacement in accordance with manufacturer's recommendations.

5.2 ENGINE SYSTEM

Refer to **Appendix I** for engine operating instructions in addition to the following:

- Check and assure proper engine oil level before each operation.
- Check reduction gear oil level periodically depending on usage.

5.3 FLUID SYSTEM



WARNING!

Pump must never be run dry for greater than one minute, refer to Appendix II.

5.3.1 To Prime Pump

The pump must be primed by the following procedure:

1. With the tank level, fill one-quarter (1/4) full with fluid.
2. Loosen relief valve locking nut by turning counter-clockwise until the internal spring is free.
3. Start engine and allow pump to re-circulate fluid back to the tank, thereby forcing air from the pump and lines.
4. When the system has been fully primed, turn the relief valve adjusting handle clockwise until the desired spray pattern has been reached. Tighten locknut by turning clockwise.

5.3.2 To Clean Pump Suction Strainer:

1. Shut off engine/pump.
2. Loosen and remove 3/8 inch hex head plug from strainer and allow fluid to back flush strainer. Re-install and tighten.

5.4 TRAILER SYSTEM

- Exercise care when towing trailer. Maximum towing speed is 10 MPH.
- When trailer is to be removed from towing vehicle, chock wheels prior to disconnecting.

6.0 MAINTENANCE**6.1 ENGINE SYSTEM**

Refer to **Appendix I** for engine maintenance information.

6.2 FLUID SYSTEM

Refer to **Appendix II** for pump maintenance information.

6.3 TRAILER SYSTEM

Lubricate wheel bearings periodically with general purpose lithium bearing grease.

7.0 STORAGE**7.1 GENERAL**

a) Refer to **Appendix I** for engine storage information.

b) If unit is to be stored:

1. Empty tanks by running pump until there is no flow through the hose.
2. If there is a potential of temperatures reaching freezing, pour one to two (1 to 2) gallons of anti-freeze into smaller tank at tow end of unit. Start engine and run pump until anti-freeze flows through the hose.
3. Store in dry area.

8.0 PROVISION OF SPARES**8.1 SOURCE OF SPARE PARTS**

Spare parts may be obtained from the manufacturer:

TRONAIR, Inc.

1 Air Cargo Pkwy East
Swanton, Ohio 43558 USA

Telephone: (419) 866-6301 or 800-426-6301

Fax: (419) 867-0634

E-mail: sales@tronair.com

Website: www.tronair.com

For Spare Parts, Operations & Service Manuals or Service Needs:
Scan the QR code or visit Tronair.com/aftermarket

**8.2 RECOMMENDED SPARE PARTS LISTS**

Reference the following page(s) for Replacement Parts and Kits available.

9.0 IN SERVICE SUPPORT

Contact Tronair, Inc. for technical services and information. See Section 1.3 – Manufacturer.

10.0 GUARANTEES/LIMITATION OF LIABILITY

Tronair products are warranted to be free of manufacturing or material defects for a period of one year after shipment to the original customer. This is solely limited to the repair or replacement of defective components. This warranty does not cover the following items:

- a) Parts required for normal maintenance
- b) Parts covered by a component manufacturers warranty
- c) Replacement parts have a 90-day warranty from date of shipment

If you have a problem that may require service, contact Tronair immediately. Do not attempt to repair or disassemble a product without first contacting Tronair, any action may affect warranty coverage. When you contact Tronair be prepared to provide the following information:

- a) Product Model Number
- b) Product Serial Number
- c) Description of the problem

If warranty coverage is approved, either replacement parts will be sent or the product will have to be returned to Tronair for repairs. If the product is to be returned, a Return Material Authorization (RMA) number will be issued for reference purposes on any shipping documents. Failure to obtain a RMA in advance of returning an item will result in a service fee. A decision on the extent of warranty coverage on returned products is reserved pending inspection at Tronair. Any shipments to Tronair must be shipped freight prepaid. Freight costs on shipments to customers will be paid by Tronair on any warranty claims only. Any unauthorized modification of the Tronair products or use of the Tronair products in violation of cautions and warnings in any manual (including updates) or safety bulletins published or delivered by Tronair will immediately void any warranty, express or implied.

The obligations of Tronair expressly stated herein are in lieu of all other warranties or conditions expressed or implied. **Any unauthorized modification of the Tronair products or use of the Tronair products in violations of cautions and warnings in any manual (including updates) or safety bulletins published or delivered by Tronair will immediately void any warranty, express or implied and Tronair disclaims any and all liability for injury (WITHOUT LIMITATION and including DEATH), loss or damage arising from or relating to such misuse.**

11.0 APPENDICIES

- APPENDIX I Hypro Gasoline Engines Manual
- APPENDIX II Hypro Diaphragm Pumps Manual

Parts List

When ordering replacement parts/kits, please specify model, serial number and color of your unit.

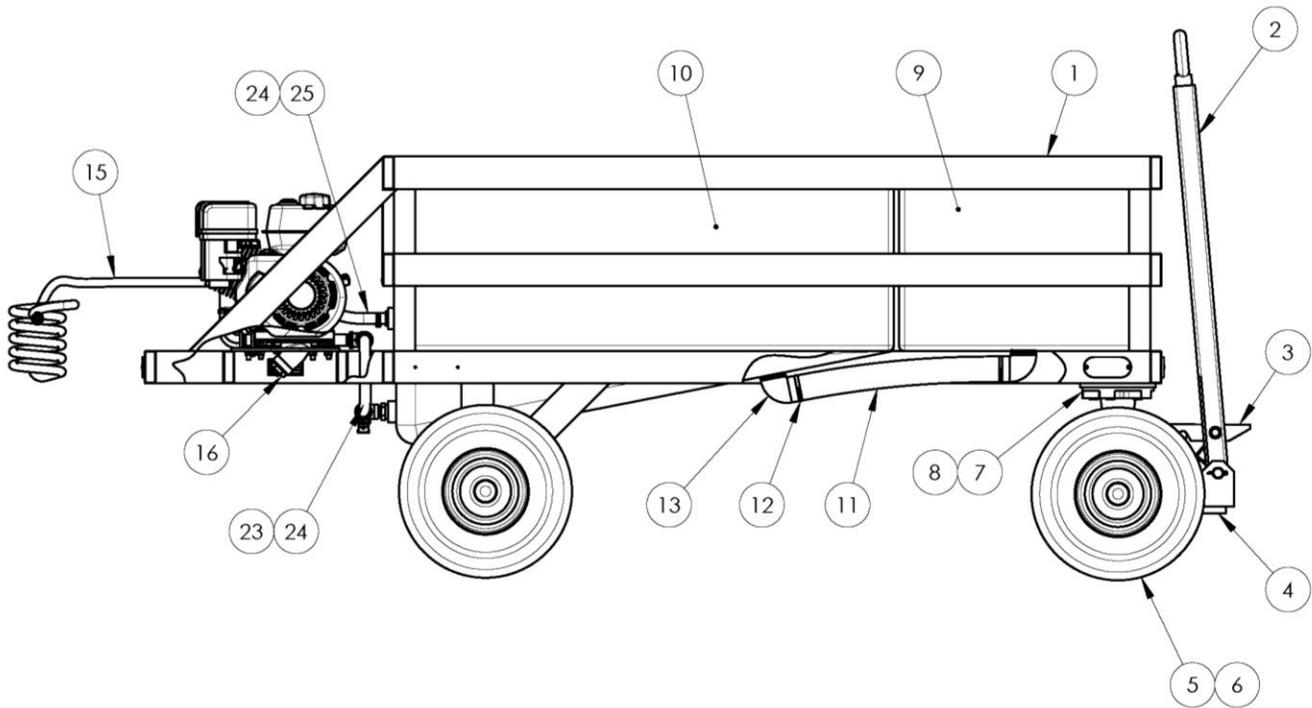

Parts List

When ordering replacement parts/kits, please specify model, serial number and color of your unit.

Item	Part Number	Description	Qty
1	Z-5517-00	WELDMENT, FRAME	1
4	Z-1633-00	WELDMENT, TRUCK	1
5	U-1010	WHEEL	4
9	H-1670	TANK, 68 GALLON	1
10	H-1542	TANK, 136 GALLON	1
11	TF-1006*21.0	HOSE, 2" I.D. X 21" LONG	1
12	H-1426-09	HOSE CLAMP	2
13	N-1504-06	ELBOW, 2"	2
15	Z-3892	ASSEMBLY, SPRAY WAND	1
16	WC-1004	STRAINER	1
23	TF-1143-12-24.0	HOSE, LOW PRESSURE	1
24	H-1426-04	HOSE CLAMP	4
25	TF-1143-12-15.0	HOSE, LOW PRESSURE	1
2	K-1781	KIT, TOWBAR REPLACEMENT; consists of:	
	G-1301-05	PIN, COTTER, 5/32" DIAMETER X 1 1/2" LONG	2
	J-1496	LEVER, LOCKING	1
	R-1159	PIN, TOWBAR	1
	Z-1635-01	WELDMENT, TOWBAR	1
3	K-1631	KIT, LOCKING LEVER REPLACEMENT; consists of:	
	G-1100-109526	BOLT, HEX HEAD, GRADE 5, 1/2-20 X 2 3/4" LONG	1
	G-1202-1095	STOPNUT, 1/2-20 ELASTIC	1
	G-1250-1090N	FLATWASHER, 1/2 NARROW	1
	J-1496	LEVER, LOCKING	1
6	K-1633	KIT, WHEEL & BEARING REPLACEMENT; consists of:	
	G-1230-01	NUT, AXLE, 1"-14 NF	1
	H-1155-01	CAP, DUST	1
	H-1559-01	BEARINGS	2
	H-1561-05	SEAL, GREASE	1
	H-1676-01	CUPS, BEARING	2
7	K-1645	KIT, HUB REPLACEMENT; consists of:	
	G-1202-1095	STOPNUT, 1/2-20 ELASTIC	5
	G-1230-01	NUT, AXLE, 1"-14 NF	1
	G-1250-1090N	FLATWASHER, 1/2 NARROW	5
	G-1279	WASHER, SPINDLE WITH TONGUE	1
	G-1301-05	PIN, COTTER, 5/32" DIAMETER X 1-1/2" LONG	1
	Z-1941	ASSEMBLY, HUB	1
8	K-1634	KIT, BEARING & SEAL; consists of:	
	H-1561-06	SEAL, GREASE	1
	H-1559-01	BEARING	1
	H-1559-10	BEARING	1
	H-1676-01	CUPS, BEARING	1
	H-1676-05	CUPS, BEARING	1
	H-1155-01	CAP, DUST	1
	G-1301-05	PIN, COTTER, 5/32" DIAMETER X 1-1/2" LONG	1
	G-1279	NUT, AXLE, 1"-14 NF	1
	G-1301-05	WASHER, SPINDLE	1

Parts List

When ordering replacement parts/kits, please specify model, serial number and color of your unit.

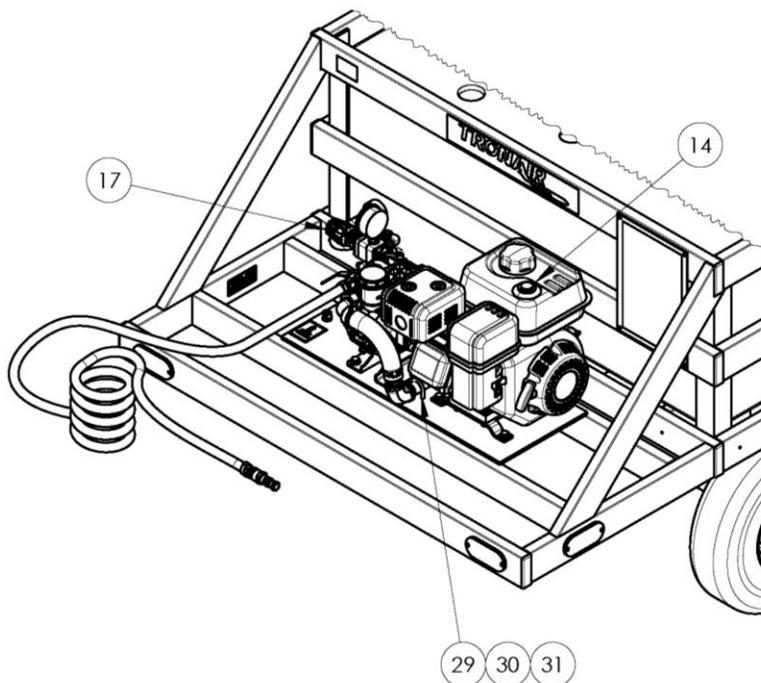

Item	Part Number	Description	Qty
14	H-5011	ENGINE, 6.5 H.P.	1
17	H-5012	PUMP	1
29	G-1009-08	U-BOLT	2
30	G-1202-1055	STOPNUT, 1/4-28 ELASTIC	4
31	G-1250-1050N	FLATWASHER, 1/2 NARROW	4
N/S	K-5586	KIT, DIAPHRAGM REPLACEMENT	
N/S	K-5587	KIT, PUMP VALVE REPLACEMENT	

Parts List

When ordering replacement parts/kits, please specify model, serial number and color of your unit.

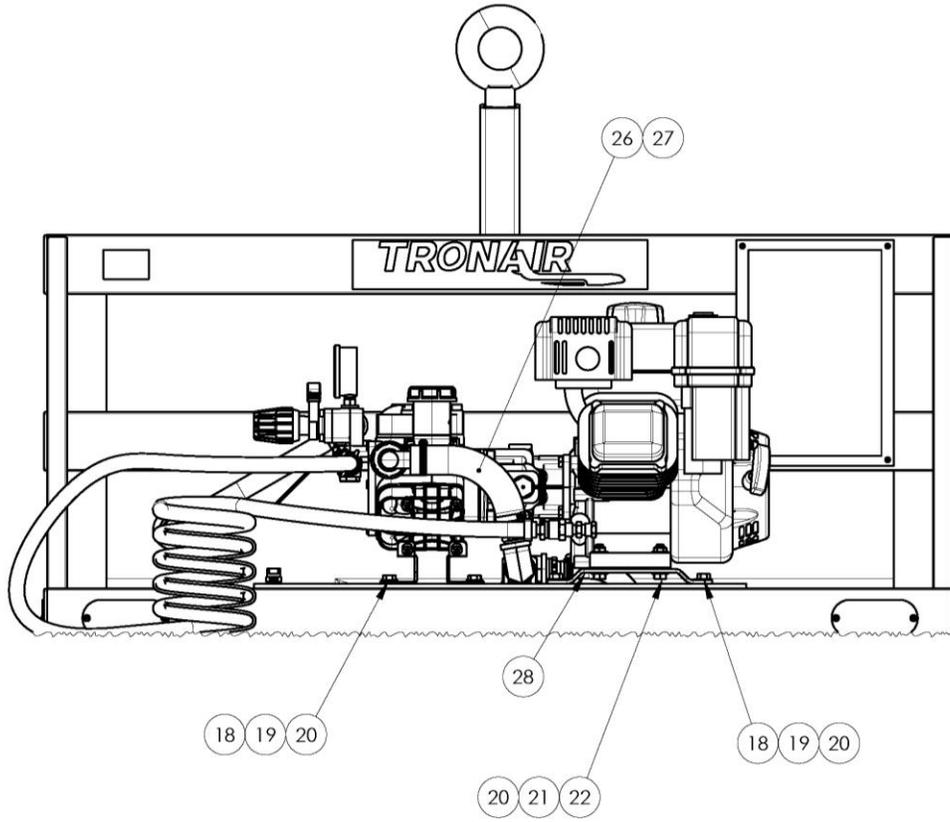

Item	Part Number	Description	Qty
18	G-1100-107512	BOLT, HEX HEAD, GRADE 5, 3/8-24 X 1-1/2" LONG	8
19	G-1202-1075	STOPNUT, 3/8-24 ELASTIC	8
20	G-1250-1070N	FLATWASHER, 3/8 NARROW	22
21	G-1100-107514	BOLT, HEX HEAD, GRADE 5, 3/8-24 X 1-1/2" LONG	4
22	G-1203-1075	JAMNUT, 3/8-24	4
26	TF-1143-16-09.0	HOSE, LOW PRESSURE	1
27	H-1426-07	HOSE CLAMP	2
28	S-4321	ENGINE MOUNTING BRACKET	1



APPENDIX I

Hypro Gasoline Engines Manual



HYPRO®

PowerPro Gasoline Engines

Form L-1512
5/12, Rev. B

Operation, Repair, and Parts Manual

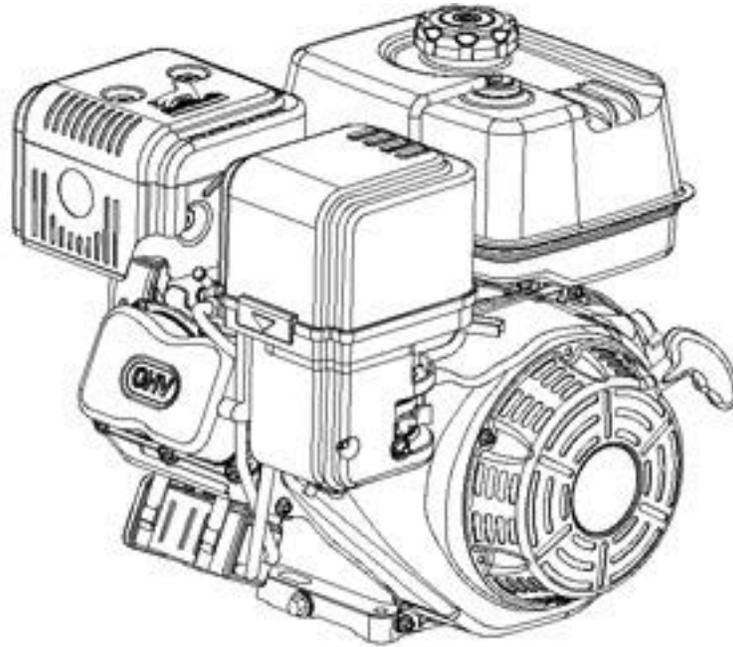

PowerPro Model Number 200 and 390

- HY200 (6.5 hp) - 2541-0045 (3/4" keyed shaft)
- 2541-0046 (5/8" threaded shaft)
- HY390 (13.0 hp) - 2541-0048 (1" keyed shaft)
- 2541-0049 (1" keyed shaft w/electric start)
- 2541-0050 (1" threaded shaft)
- 2541-0051 (1" threaded shaft w/electric start)

Note: Unit is not shipped with oil. Please add oil to engine prior to operating.

Table of Contents

ENGINE SAFETY	3
COMPONENTS & CONTROL LOCATIONS	4
CONTROLS.....	5
CHECK BEFORE OPERATION	6
OPERATION	7
MAINTENANCE	9
STORAGE/TRANSPORTATION.....	16
TROUBLESHOOTING	18
TECHNICAL & CONSUMER INFORMATION.....	19
SPECIFICATIONS.....	22
ENGINE REPLACEMENT PARTS.....	23
WIRING DIAGRAMS	24
OPTIONAL PARTS – BATTERY	26
EMISSIONS WARRANTY	27

READ THIS OWNER'S MANUAL CAREFULLY. Pay special attention to these symbols and any instructions that follow:

▲ DANGER Indicates serious injury or death will result if instructions are not followed.

▲ WARNING Indicates a strong possibility that serious injury or death could result if instructions are not followed.

▲ CAUTION Indicates a possibility that minor injury could result if instructions are not followed.

NOTICE Indicates that equipment or property damage can result if instructions are not followed.

NOTE Gives helpful information.

Engine Safety Information

▲ California Proposition 65 Warning -- This product and related accessories contain chemicals known to the State of California to cause cancer, birth defects or other reproductive harm.

IMPORTANT SAFETY INFORMATION

Most accidents with engines can be prevented if you follow all instructions in this manual and on the engine. Some of the most common hazards are discussed below, along with the best way to protect yourself and others.

Owner Responsibilities

- The engines are designed to give safe and dependable service if operated according to instructions. Read and understand this owner's manual before operating the engine. Failure to do so could result in personal injury or equipment damage.
- Know how to stop the engine quickly, and understand the operation of all controls. Never permit anyone to operate the engine without proper instructions.
- Do not allow children to operate the engine. Keep children and pets away from the area of operation.

Refuel with Care

Gasoline is extremely flammable, and gasoline vapor can explode. Refuel outdoors, in a well-ventilated area, with the engine stopped. Never smoke near gasoline, and keep other flames and sparks away. Always store gasoline in an approved container. If any fuel is spilled, make sure the area is dry before starting the engine.

Hot Exhaust

- The muffler becomes very hot during operation and remains hot for a while after stopping the engine. Be careful not to touch the muffler while it is hot. Let the engine cool before storing it indoors.
- To prevent fire hazards and to provide adequate ventilation for stationary equipment applications, keep the engine at least 3 feet (1 meter) away from building walls and other equipment during operation. Do not place flammable objects close to the engine.

Carbon Monoxide Hazard

Exhaust gas contains poisonous carbon monoxide. Avoid inhalation of exhaust gas. Never run the engine in a closed garage or confined area.

Other Equipment

Review the instructions provided with the equipment powered by this engine for any additional safety precautions that should be observed in conjunction with engine startup, shutdown, operation, or protective apparel that may be needed to operate the equipment.

Components & Control Locations

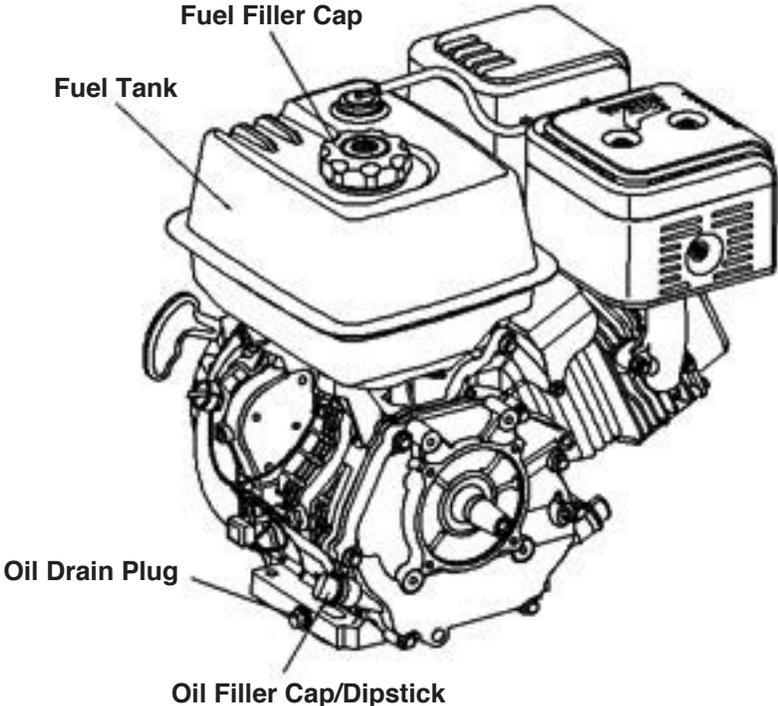
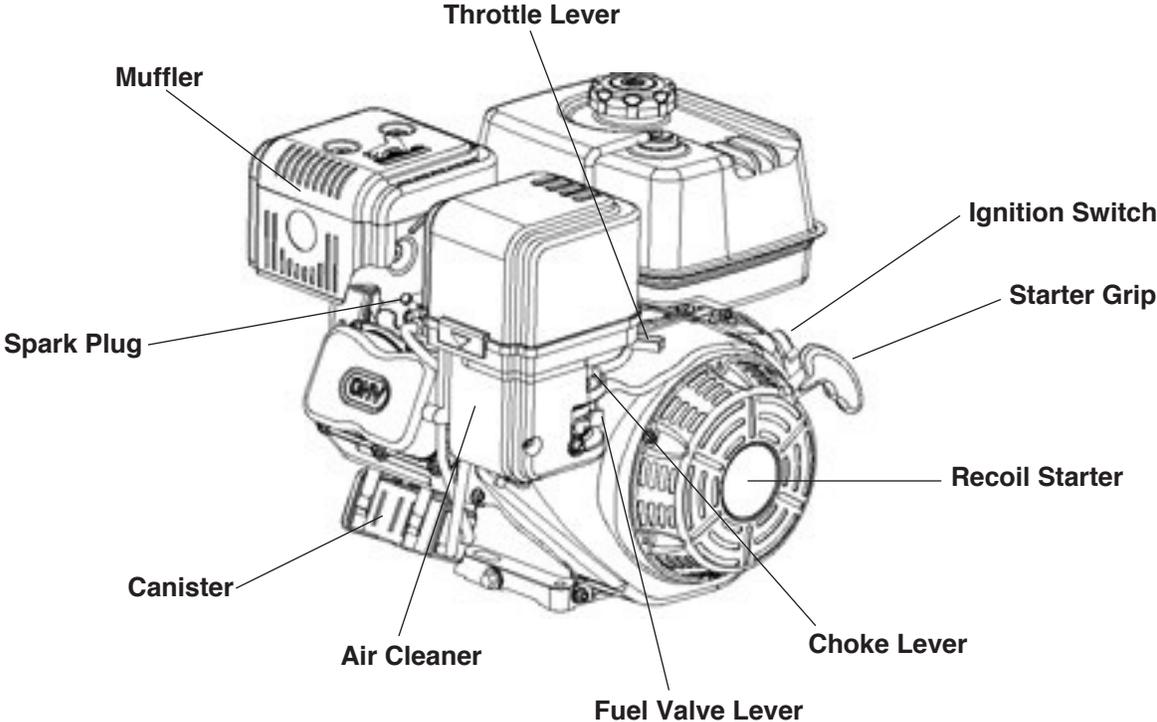

Controls

Fuel Valve Lever

The fuel valve opens and closes the passage between the fuel tank and the carburetor. The fuel valve lever must be in the ON position for the engine to run. When the engine is not in use, leave the fuel valve lever in the OFF position to prevent carburetor flooding and to reduce the possibility of fuel leakage.

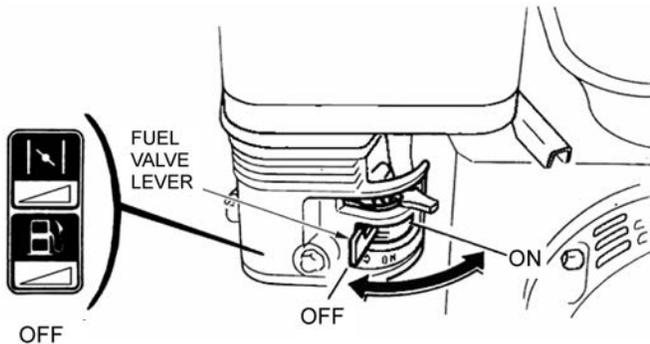

Choke Lever

The choke lever opens and closes the choke valve in the carburetor. The CLOSE position enriches the fuel mixture for starting a cold engine. The OPEN position provides the correct fuel mixture for operation after starting and for restarting a warm engine.

Some engine applications use a remotely-mounted choke control rather than the engine-mounted choke lever shown here.

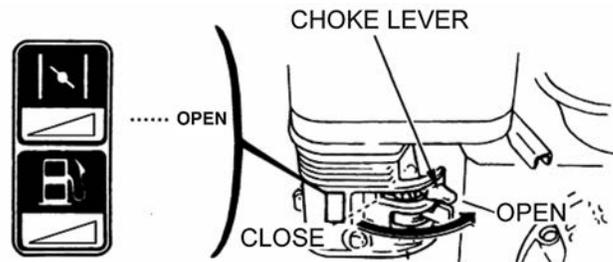

Throttle Lever

The throttle lever controls engine speed. Moving the throttle lever in the directions (shown below) makes the engine run faster or slower.

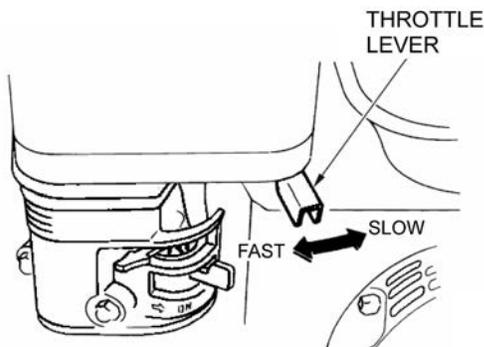

Recoil Starter Grip

Pulling the starter grip operates the recoil starter to crank the engine.

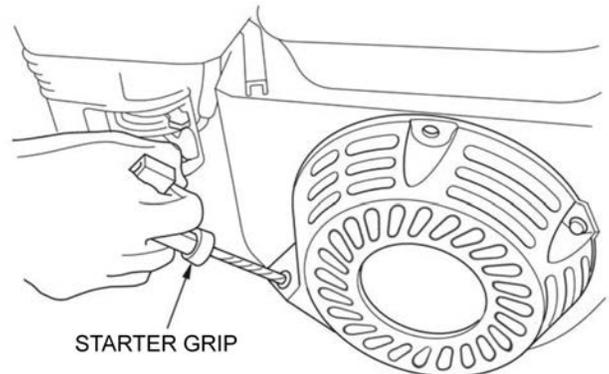

Engine Switch

The engine switch enables and disables the ignition system. The engine switch must be in the ON position for the engine to run. Turning the engine switch to the OFF position stops the engine.

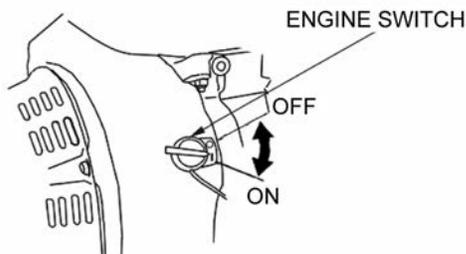

Check Before Operation

IS YOUR ENGINE READY TO GO?

For your safety, and to maximize the service life of your equipment, it is very important to take a few moments before you operate the engine to check its condition. Be sure to take care of any problem you find, or have your servicing dealer correct it, prior to operating the engine.

⚠ WARNING

Improperly maintaining this engine, or failing to correct a problem before operation, could cause a malfunction in which you could be seriously injured.

Always perform a preoperation inspection before each operation, and correct any problem.

Before beginning your preoperation checks, be sure the engine is level and the engine switch is in the OFF position.

Check the General Condition of the Engine

- Look around and underneath the engine for signs of oil or gasoline leaks.
- Remove any excessive dirt or debris, especially around the muffler and recoil starter.
- Look for signs of damage.
- Check that all shields and covers are in place, and all nuts, bolts, and screws are tightened.

Check the Engine

- Check the engine oil level. Running the engine with a low oil level can cause engine damage. The Low Oil Sensor (applicable engine types) will automatically stop the engine before the oil level falls below safe limits. However, to avoid the inconvenience of an unexpected shutdown, always check the engine oil level before startup.
- Check the air filter. A dirty air filter will restrict air flow to the carburetor, reducing engine performance.
- Check the fuel level. Starting with a full tank will help to eliminate or reduce operating interruptions for refueling.

Check the Equipment Powered by this Engine

Review the instructions provided with the equipment powered by this engine for any precautions and procedures that should be followed before engine startup.

Operation

SAFE OPERATING PRECAUTIONS

Before operating the engine for the first time, please review the **IMPORTANT SAFETY INFORMATION** and the section titled **BEFORE OPERATION**.

⚠ WARNING

Carbon monoxide gas is toxic. Breathing it can cause unconsciousness and even death.

Avoid any areas or actions that expose you to carbon monoxide.

Review the instructions provided with the equipment powered by this engine for any safety precautions that should be observed in conjunction with engine startup, shutdown, or operation.

STARTING THE ENGINE

1. Move the fuel valve lever to the ON position.

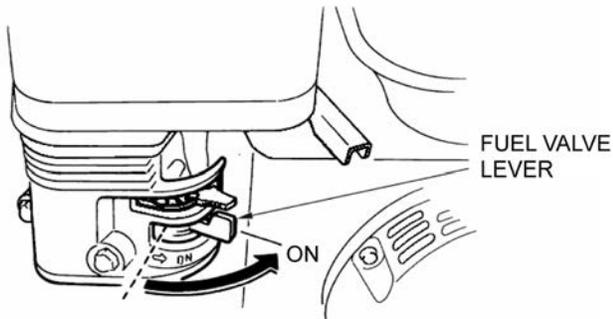

2. To start a cold engine, move the choke lever to the CLOSE position.

To restart a warm engine, leave the choke lever in the OPEN position.

Some engine applications use a remotely-mounted choke control rather than the engine-mounted choke lever shown here.

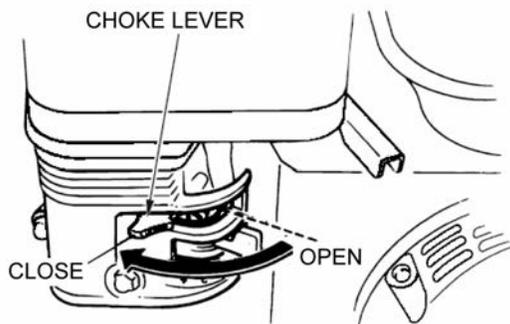

3. Move the throttle lever away from the SLOW position, about 1/3 of the way toward the FAST position.

Some engine applications use a remotely-mounted throttle control rather than the engine-mounted throttle lever shown here.

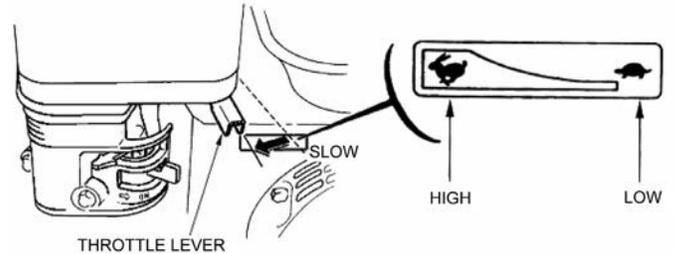

4. Turn the engine switch to the ON position.

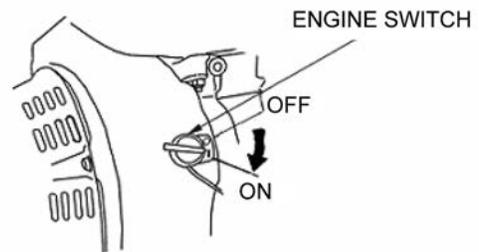

5. Operate the starter.

RECOIL STARTER (all engine types):

Pull the starter grip lightly until you feel resistance, then pull briskly.

Return the starter grip gently.

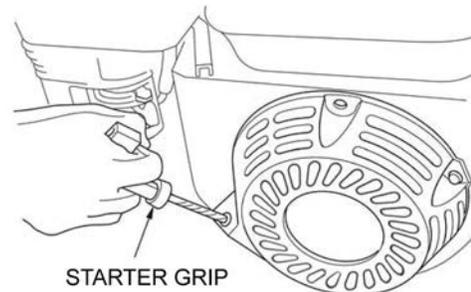

6. If the choke lever has been moved to the CLOSE position to start the engine, gradually move it to the OPEN position as the engine warms up.

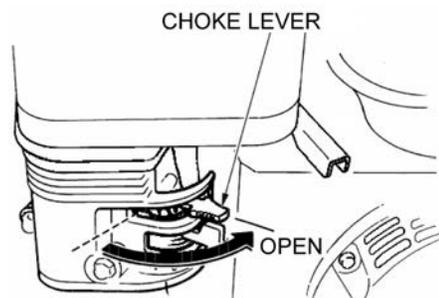

Operation

SETTING ENGINE SPEED

Position the throttle lever for the desired engine speed. Some engine applications use a remotely-mounted throttle control rather than the engine-mounted throttle lever shown here.

For engine speed recommendations, refer to the instructions provided with the equipment powered by this engine.

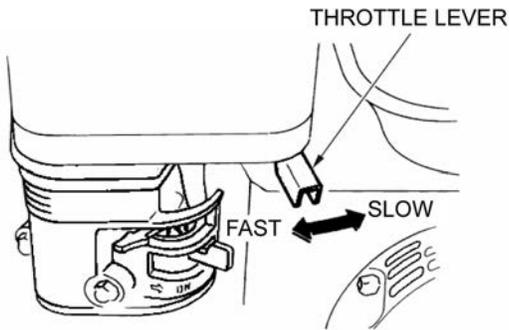

STOPPING THE ENGINE

To stop the engine in an emergency, simply turn the engine switch to the OFF position. Under normal conditions, use the following procedure.

1. Move the throttle lever to the SLOW position.

Some engine applications use a remotely-mounted throttle control rather than the engine-mounted throttle lever shown here.

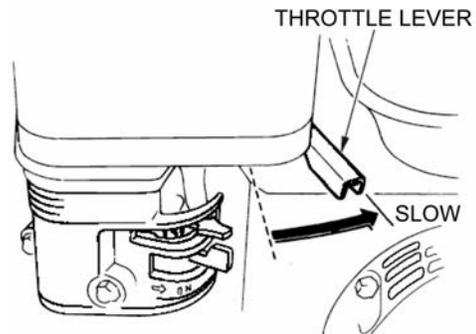

2. Turn the engine switch to the OFF position.

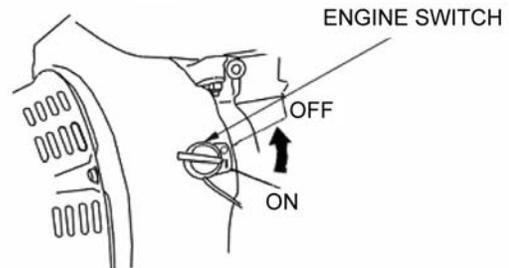

3. Turn the fuel valve lever to the OFF position.

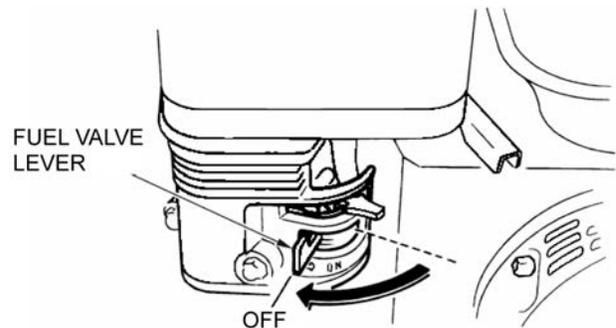

Maintenance

THE IMPORTANCE OF MAINTENANCE

Good maintenance is essential for safe, economical, and trouble-free operation. It will also help reduce air pollution.

⚠ WARNING

Improperly maintaining this engine, or failure to correct a problem before operation, can cause a malfunction in which you can be seriously hurt or killed.

Always follow the inspection and maintenance recommendations and schedules in this owner's manual.

To help you properly care for your engine, the following pages include a maintenance schedule, routine inspection procedures, and simple maintenance procedures using basic hand tools. Other service tasks that are more difficult, or require special tools, are best handled by professionals and are normally performed by a technician or other qualified mechanic.

The maintenance schedule applies to normal operating conditions. If you operate your engine under unusual conditions, such as sustained high-load or high-temperature operation, or use in unusually wet or dusty conditions, consult your servicing dealer for recommendations applicable to your individual needs and use.

MAINTENANCE SAFETY

Some of the most important safety precautions are as follows. (Note: We cannot warn you of every conceivable hazard that can arise in performing maintenance. Only you can decide whether or not you should perform a given task.)

⚠ WARNING

Failure to properly follow maintenance instructions and precautions can cause you to be seriously hurt or killed.

Always follow the procedures and precautions in the owner's manual.

Safety Precautions

- Make sure the engine is off before you begin any maintenance or repairs. This will eliminate several potential hazards:
 - Carbon monoxide poisoning from engine exhaust. Be sure there is adequate ventilation whenever you operate the engine.
 - Burns from hot parts. Let the engine and exhaust system cool before touching.
 - Injury from moving parts. Do not run the engine unless instructed to do so.
- Read the instructions before you begin, and make sure you have the tools and skills required to perform the maintenance.
- To reduce the possibility of fire or explosion, be careful when working around gasoline. Use only a nonflammable solvent, not gasoline, to clean parts. Keep cigarettes, sparks and flames away from all fuel-related parts.

Remember that your servicing dealer knows your engine best and is fully equipped to maintain and repair it.

To ensure the best quality and reliability, use only new, genuine parts or their equivalents for repair and replacement.

Maintenance

MAINTENANCE SCHEDULE

REGULAR SERVICE PERIOD Performed at every indicated month or operating hour interval, whichever comes first.		Item	Each use	First month or 20 hours	Every 3 months or 50 hours	Every 6 months or 100 hours	Every year or 300 hours	
•	Engine oil	Check level	°					
		Change		°		°		
•	Air cleaner	Check	°					
		Clean			°(1)			
		Replace					°†	
•	Sediment cup	Clean				°		
•	Spark plug	Check-Clean				°		
		Replace					°	
	Spark arrester (optional parts)	Clean				°		
•	Idle speed	Check-Adjust					°(2)	
•	Valve clearance	Check-Adjust					°(2)	
•	Fuel tank and strainer	Clean					°(2)	
•	Combustion chamber	Clean	After every 300 Hrs. (2)					
•	Fuel line	Check	Every 2 years (Replace if necessary) (2)					

°Emission-related items.

† Replace the paper element type only.

(1) Service more frequently when used in dusty areas.

(2) These items should be serviced by your servicing dealer unless you have the proper tools and are mechanically proficient.

REFUELING

Part Number	HP	Fuel Tank Capacity	
2541-0045	6.5	3.6 L	0.95 Gal
2541-0046			
2541-0048	13	6.5 L	1.7 Gal
2541-0049			
2541-0050			
2541-0051			

With the engine stopped, remove the fuel tank cap and check the fuel level. Refill the tank if the fuel level is low.

⚠ WARNING

Gasoline is highly flammable and explosive. You can be burned or seriously injured when handling fuel.

- **Stop the engine and keep heat, sparks and flame away.**
- **Handle fuel only outdoors.**
- **Wipe up spills immediately.**

MAXIMUM FUEL LEVEL

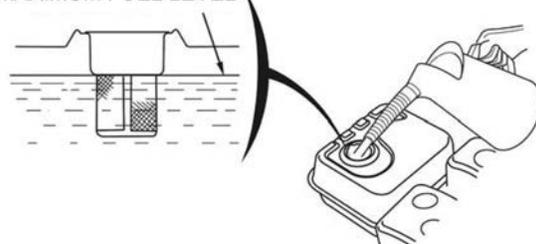

Refuel in a well-ventilated area before starting the engine. If the engine has been running, allow it to cool. Refuel carefully to avoid spilling fuel. Do not fill above the fuel strainer shoulder. After refueling, tighten the fuel tank cap securely.

Never refuel the engine inside a building where gasoline fumes may reach flames or sparks. Keep gasoline away from appliance pilot lights, barbecues, electric appliances, power tools, etc.

Maintenance

Spilled fuel is not only a fire hazard, it causes environmental damage. Wipe up spills immediately.

NOTICE

Fuel can damage paint and plastic. Be careful not to spill fuel when filling your fuel tank. Damage caused by spilled fuel is not covered under warranty.

FUEL RECOMMENDATIONS

Use unleaded gasoline with a pump octane rating of 86 or higher.

These engines are certified to operate on unleaded gasoline. Unleaded gasoline produces fewer engine and spark plug deposits and extends exhaust system life.

Never use stale or contaminated gasoline or an oil/gasoline mixture. Avoid getting dirt or water in the fuel tank.

Occasionally you may hear a light “spark knock” or “pinging” (metallic rapping noise) while operating under heavy loads. This is no cause for concern.

If spark knock or pinging occurs at a steady engine speed, under normal load, change brands of gasoline. If spark knock or pinging persists, see an authorized servicing dealer.

NOTICE

Running the engine with persistent spark knock or pinging can cause engine damage.

Running the engine with persistent spark knock or pinging is considered misuse, and Hypro's Limited Warranty does not cover parts damaged by misuse.

ENGINE OIL LEVEL CHECK

Check the engine oil level with the engine stopped and in a level position.

1. Remove the filler cap/dipstick and wipe it clean.

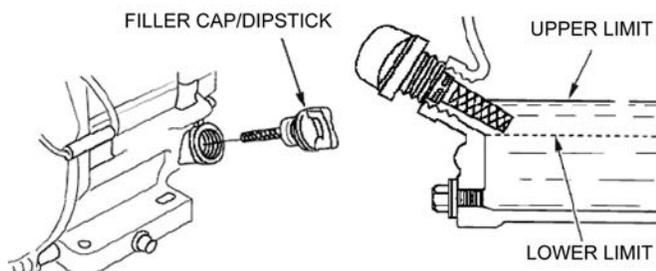

2. Insert and remove the dipstick without screwing it into the filler neck. Check the oil level shown on the dipstick.

3. If the oil level is low, fill to the edge of the oil filler hole with the recommended oil.
4. Screw in the filler cap/dipstick securely.

NOTICE

Running the engine with a low oil level can cause engine damage.

The Low Oil Sensor (applicable engine types) will automatically stop the engine before the oil level falls below safe limit. However, to avoid the inconvenience of an unexpected shutdown, always check the engine oil level before startup.

ENGINE OIL CHANGE

Drain the used oil while the engine is warm. Warm oil drains quickly and completely.

1. Place a suitable container below the engine to catch the used oil, and then remove the filler cap/dipstick and the drain plug.
2. Allow the used oil to drain completely, and then reinstall the drain plug and tighten it securely.

Please dispose of used motor oil in a manner that is compatible with the environment. We suggest you take used oil in a sealed container to your local recycling center or service station for reclamation. Do not throw it in the trash, pour it on the ground, or down a drain.

3. With the engine in a level position, fill to the outer edge of the oil filler hole with the recommended oil.

ENGINE OIL CAPACITIES:

Part Number	HP	Oil Capacity	
2541-0045	6.5	0.60 L	0.63 Qt
2541-0046			
2541-0048	13	1.1 L	1.2 Qt
2541-0049			
2541-0050			
2541-0051			

Running the engine with a low oil level can cause engine damage.

The Low Oil Sensor (applicable engine types) will automatically stop the engine before the oil level falls below the safe limit.

Maintenance

However, to avoid the inconvenience of an unexpected shutdown, fill to the upper limit, and check the oil level regularly.

4. Screw in the filler cap/dipstick securely.

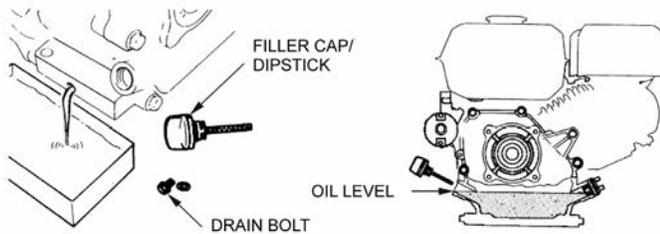

SERVICING YOUR ENGINE ENGINE OIL RECOMMENDATIONS

Oil is a major factor affecting performance and service life. Use 4-stroke automotive detergent oil.

SAE 10W-30 is recommended for general use. Other viscosities shown in the chart may be used when the average temperature in your area is within the recommended range.

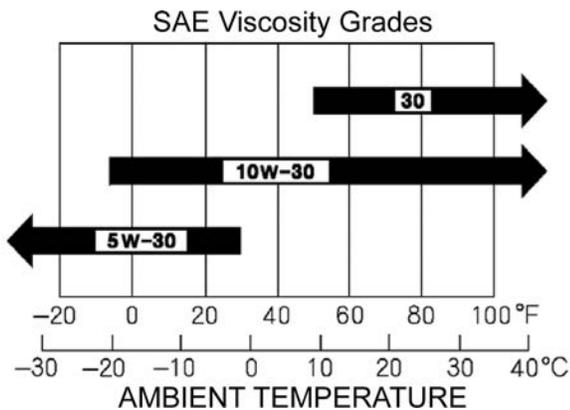

The SAE oil viscosity and service classification are in the API label on the oil container. We recommend that you use API SERVICE Category SG or SH oil.

AIR FILTER INSPECTION

Remove the air cleaner cover and inspect the filter. Clean or replace dirty filter elements. Always replace damaged filter elements. If equipped with an oil-bath air cleaner, also check the oil level.

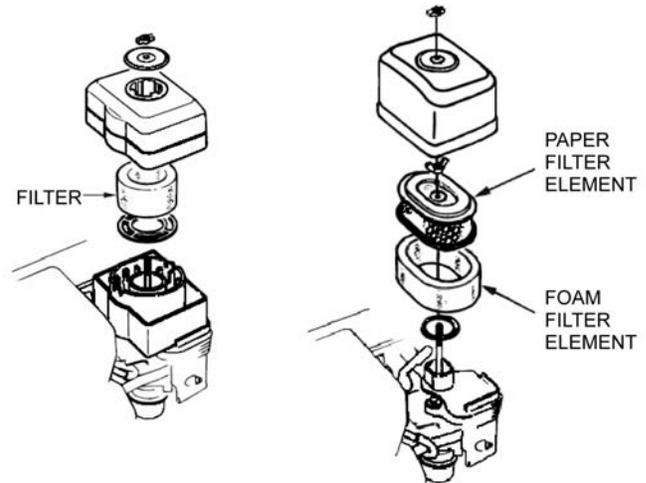

AIR CLEANER SERVICE

A dirty air filter will restrict air flow to the carburetor, reducing engine performance.

If you operate the engine in very dusty areas, clean the air filter more often than specified in the MAINTENANCE SCHEDULE.

NOTICE

Operating the engine without an air filter, or with a damaged air filter, will allow dirt to enter the engine, causing rapid engine wear. This type of damage is not covered by Hypro's Limited Warranty.

Maintenance

Dual-Filter Element Types

1. Remove the wing nut from the air cleaner cover, and remove the air cleaner cover.
2. Remove the wing nut from the air filter, and remove the filter.
3. Remove the foam filter from the paper filter.
4. Inspect both air filter elements, and replace them if they are damaged. Always replace the paper air filter element at the scheduled interval.
5. Clean the air filter elements if they are to be reused.

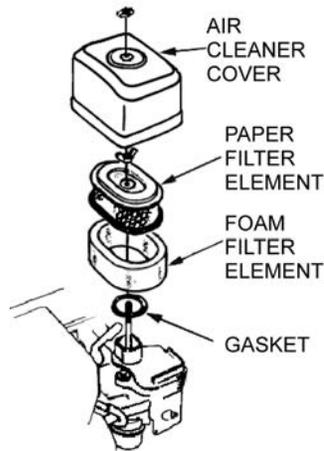

Paper air filter element: Tap the filter element several times on a hard surface to remove dirt, or blow compressed air [not exceeding 30 psi (207 kPa)] through the filter element from the inside. Never try to brush off dirt; brushing will force dirt into the fibers.

Foam air filter element: Clean in warm, soapy water, rinse, and allow drying thoroughly. Or clean in nonflammable solvent and allow drying. Dip the filter element in clean engine oil, and then squeeze out all excess oil. The engine will smoke when started if too much oil is left in the foam.

1. Using a moist rag, wipe dirt from the inside of the air cleaner base and cover. Be careful to prevent dirt from entering the air duct that leads to the carburetor.
2. Place the foam air filter element over the paper element, and reinstall the assembled air filter. Be sure the gasket is in place beneath the air filter. Tighten the air filter wing nut securely.
3. Install the air cleaner cover, and tighten the cover wing nut securely.

Oil-Bath Type

1. Remove the wing nut, and remove the air cleaner cap and cover.
2. Remove the air filter from the cover, wash the cover and filter in warm, soapy water, rinse, and allow drying thoroughly. Or clean in nonflammable solvent and allow drying.
3. Dip the filter in clean engine oil, and then squeeze out all excess oil. The engine will smoke if too much oil is left in the foam.
4. Empty the used oil from the air cleaner case, wash out any accumulated dirt with nonflammable solvent, and dry the case.
5. Fill the air cleaner case to the OIL LEVEL mark with the same oil that is recommended for the engine. Oil capacity: 2.0 US oz (60 cm³)
6. Reassemble the air cleaner, and tighten the wing nut securely.

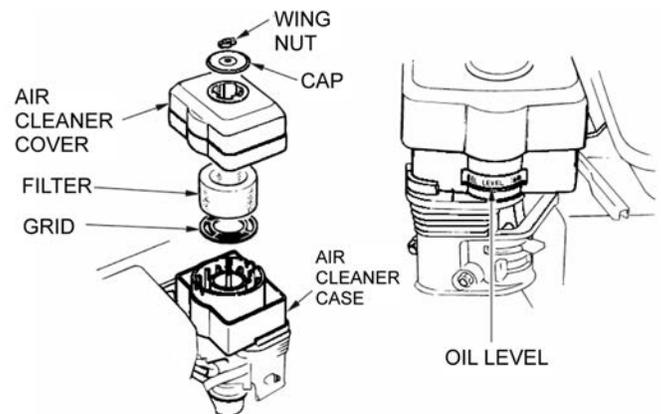

Maintenance

SEDIMENT CUP CLEANING

1. Move the fuel valve to the OFF position, and then remove the fuel sediment cup and O-ring.

⚠ WARNING

Gasoline is highly flammable and explosive. You can be burned or seriously injured when handling fuel.

- Keep heat, sparks and flame away.
- Handle fuel only outdoors.
- Wipe up spills immediately.

2. Wash the sediment cup and O-ring in nonflammable solvent, and dry them thoroughly.

3. Place the O-ring in the fuel valve, and install the sediment cup. Tighten the sediment cup securely.

4. Move the fuel valve to the ON position, and check for leaks. Replace the O-ring if there is any leakage.

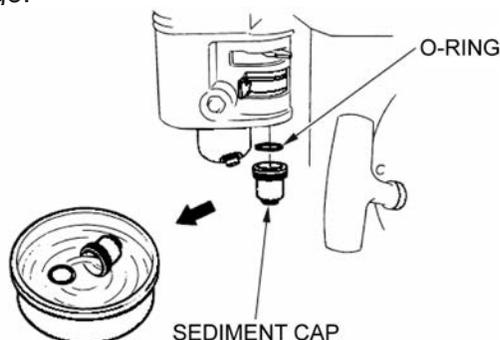

SPARK PLUG SERVICE

Recommended spark plugs: F7RTC or other equivalents.

NOTICE

An incorrect spark plug can cause engine damage.

1. Disconnect the spark plug cap, and remove any dirt from around the spark plug area.
2. Remove the spark plug with a spark plug wrench.

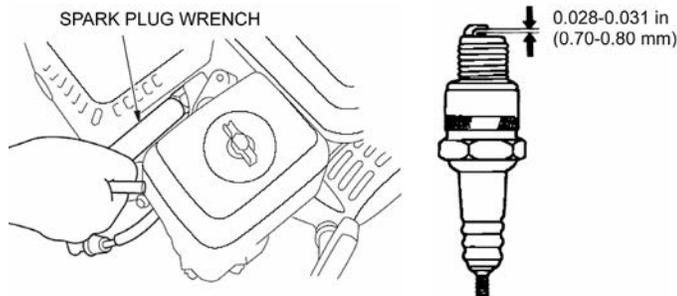

3. Inspect the spark plug. Replace it if the electrodes are worn, or if the insulator is cracked or chipped.

4. Measure the spark plug electrode gap with a suitable gauge.

The gap should be 0.028 -0.031 in (0.70 - 0.80 mm). Correct the gap, if necessary, by carefully bending the side electrode.

5. By hand, install the spark plug carefully to avoid cross-threading.

6. After the spark plug seats, tighten with a spark plug wrench to compress the washer.

If reinstalling the used spark plug, tighten 1/8 - 1/4 turn after the spark plug seats.

If installing a new spark plug, tighten 1/2 turn after the spark plug seats.

NOTICE

A loose spark plug can overheat and damage the engine. Over tightening the spark plug can damage the threads in the cylinder head.

7. Attach the spark plug cap.

IDLE SPEED ADJUSTMENT

1. Start the engine outdoors, and allow it to warm up to operating temperature.
2. Move the throttle lever to its slowest position.
3. Turn the throttle stop screw to obtain the standard idle speed.

Standard idle speed: 1,400±150 rpm

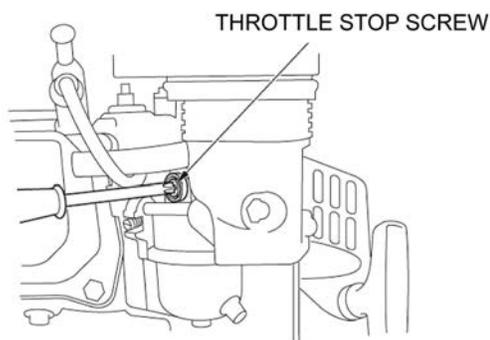

SPARK ARRESTER SERVICE (optional equipment)

Your engine is not factory-equipped with a spark arrester. In some areas, it is illegal to operate an engine without a spark arrester. Check local laws and regulations. A spark arrester is available from authorized servicing dealers.

The spark arrester must be serviced every 100 hours to keep it functioning as designed.

If the engine has been running, the muffler will be very hot. Allow the muffler to cool before servicing the spark arrester.

1. Remove the three 4 mm screws from the exhaust deflector, and remove the deflector.
2. Remove the four 5 mm screws from the muffler protector, and remove the muffler protector.
3. Remove the 4 mm screw from the spark arrester, and remove the spark arrester from the muffler.

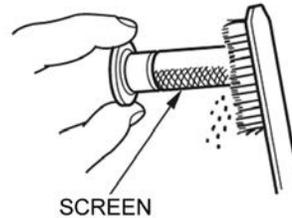

4. Use a brush to remove carbon deposits from the spark arrester screen. Be careful to avoid damaging the screen.

The spark arrester must be free of breaks and holes. Replace the spark arrester if it is damaged.

5. Install the spark arrester, muffler protector and exhaust deflector in reverse order of disassembly.

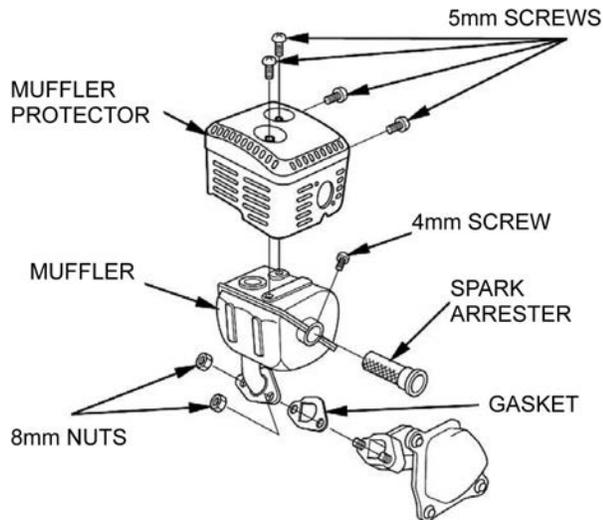

Storage/Transportation

STORING YOUR ENGINE

Storage Preparation

Proper storage preparation is essential for keeping your engine trouble free and looking good. The following steps will help to keep rust and corrosion from impairing your engine's function and appearance, and will make the engine easier to start after storage.

Cleaning

If the engine has been running, allow it to cool for at least half an hour before cleaning. Clean all exterior surfaces, touch up any damaged paint, and coat other areas that may rust with a light film of oil.

NOTICE

Using a garden hose or pressure washing equipment can force water into the air cleaner or muffler opening. Water in the air cleaner will soak the air filter, and water that passes through the air filter or muffler can enter the cylinder, causing damage.

Water contacting a hot engine can cause damage. If the engine has been running, allow it to cool for at least half an hour before washing.

Fuel

Gasoline will oxidize and deteriorate in storage. Old gasoline will cause hard starting, and it leaves gum deposits that clog the fuel system. If the gasoline in your engine deteriorates during storage, you may need to have the carburetor and other fuel system components serviced or replaced.

The length of time that gasoline can be left in your fuel tank and carburetor without causing functional problems will vary with such factors as gasoline blend, your storage temperatures, and whether the fuel tank is partially or completely filled. The air in a partially-filled fuel tank promotes fuel deterioration. Very warm storage temperatures accelerate fuel deterioration. Fuel deterioration problems may occur within a few months, or even less if the gasoline was not fresh when you filled the fuel tank.

NOTICE

Hypro's Limited Warranty does not cover fuel system damage or engine performance problems resulting from neglected storage preparation.

You can extend fuel storage life by adding a fuel stabilizer that is formulated for that purpose, or you can avoid fuel deterioration problems by draining the fuel tank and carburetor.

Adding a Fuel Stabilizer to Extend Fuel Storage Life

When adding a fuel stabilizer, fill the fuel tank with fresh gasoline. If only partially filled, air in the tank will promote fuel deterioration during storage. If you keep a container of gasoline for refueling, be sure that it contains only fresh gasoline.

1. Add fuel stabilizer following the manufacturer's instructions.
2. After adding a fuel stabilizer, run the engine outdoors for 10 minutes to be sure that treated gasoline has replaced the untreated gasoline in the carburetor.
3. Stop the engine, and move the fuel valve to the OFF position.

Draining the Fuel Tank and Carburetor

1. Place an approved gasoline container below the carburetor, and use a funnel to avoid spilling fuel.
2. Remove the carburetor drain bolt and sediment cup, and then move the fuel valve lever to the ON position.

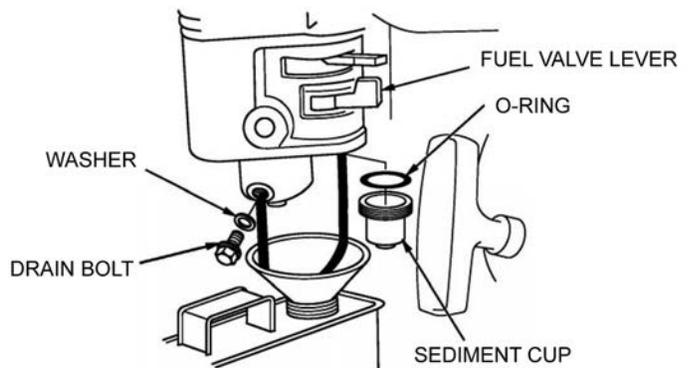

3. After all the fuel has drained into the container, reinstall the drain bolt and sediment cup. Tighten them securely.

Storage/Transportation

Storage Precautions

1. Change the engine oil.
2. Remove the spark plugs.
3. Pour a tablespoon (5-10 cc) of clean engine oil into the cylinder.
4. Pull the starter rope several times to distribute the oil in the cylinder.
5. Reinstall the spark plugs.
6. Pull the starter rope slowly until resistance is felt. This will close the valves so moisture cannot enter the engine cylinder. Return the starter rope gently.

If your engine will be stored with gasoline in the fuel tank and carburetor, it is important to reduce the hazard of gasoline vapor ignition. Select a well-ventilated storage area away from any appliance that operates with a flame, such as a furnace, water heater or clothes dryer. Also avoid any area with a spark-producing electric motor, or where power tools are operated.

If possible, avoid storage areas with high humidity, because that promotes rust and corrosion.

Unless all fuel has been drained from the fuel tank, leave the fuel valve lever in the OFF position to reduce the possibility of fuel leakage.

Position the equipment so the engine is level. Tilting can cause fuel or oil leakage.

With the engine and exhaust system cool, cover the engine to keep out dust. A hot engine and exhaust system can ignite or melt some materials. Do not use sheet plastic as a dust cover. A nonporous cover will trap moisture around the engine, promoting rust and corrosion.

If equipped with a battery for an electric starter, recharge the battery once a month while the engine is in storage. This will help to extend the service life of the battery.

Removal from Storage

Check your engine as described in the section CHECK BEFORE OPERATION.

If the fuel was drained during storage preparation, fill the tank with fresh gasoline. If you keep a container of gasoline for refueling, be sure that it contains only fresh gasoline. Gasoline oxidizes and deteriorates over time, causing hard starting.

If the cylinders were coated with oil during storage preparation, the engine may smoke briefly at start-up. This is normal.

TRANSPORTING

If the engine has been running, allow it to cool for at least 15 minutes before loading the engine-powered equipment on the transport vehicle. A hot engine and exhaust system can burn you and can ignite some materials.

Keep the engine level when transporting to reduce the possibility of fuel leakage. Move the fuel valve lever to the OFF position.

Troubleshooting

ENGINE WILL NOT START	Possible Cause	Correction
1. Electric starting: check battery.	Battery discharged.	Recharge battery.
2. Check control positions.	Fuel valve OFF. Choke OPEN. Engine switch OFF.	Move lever to ON. Move lever to CLOSE unless engine is warm. Turn engine switch to ON.
3. Check fuel.	Out of fuel. Bad fuel; engine stored without treating or draining gasoline, or refueled with bad gasoline.	Refuel. Drain fuel tank and carburetor. Refuel with fresh gasoline.
4. Remove and inspect spark plugs.	Spark plugs faulty, fouled, or improperly gapped. Spark plugs wet with fuel (flooded engine).	Gap, or replace spark plugs. Dry and reinstall spark plugs. Start engine with throttle lever in FAST position.
5. Other conditions.	Fuel filter clogged, carburetor malfunction, ignition malfunction, valve stuck, etc.	Replace or repair faulty components as necessary.

ENGINE LACKS POWER	Possible Cause	Correction
1. Check air filter.	Filter element(s) clogged.	Clean or replace filter element(s).
2. Check fuel.	Out of fuel. Bad fuel; engine stored without treating or draining gasoline, or refueled with bad gasoline.	Refuel. Drain fuel tank and carburetor. Refuel with fresh gasoline.
3. Other conditions.	Fuel filter clogged, carburetor malfunction, ignition malfunction, valve stuck, etc.	Replace or repair faulty components as necessary.

TECHNICAL INFORMATION

Serial Number Location

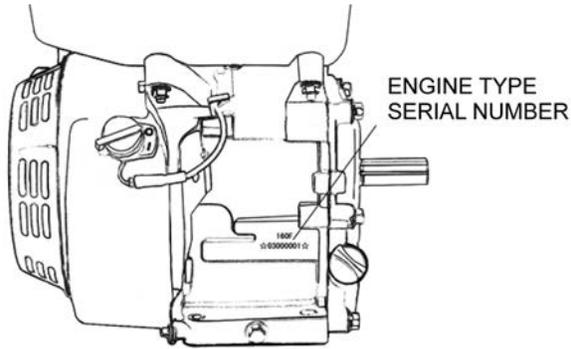

Record the engine serial number in the space below. You will need this serial number when ordering parts and when making technical or warranty inquiries.

Engine serial number: _____

Battery Connections for Electric Starter

Use a 12-volt battery with an ampere-hour rating of at least 18 Ah.

Be careful not to connect the battery in reverse polarity, as this will short circuit the battery charging system. Always connect the positive (+) battery cable to the battery terminal before connecting the negative (-) battery cable, so your tools cannot cause a short circuit if they touch a grounded part while tightening the positive (+) battery cable end.

⚠ WARNING

A battery can explode if you do not follow the correct procedure, seriously injuring anyone nearby.

Keep all sparks, open flames and smoking materials away from the battery.

1. Connect the battery positive (+) cable to the starter solenoid terminal as shown.

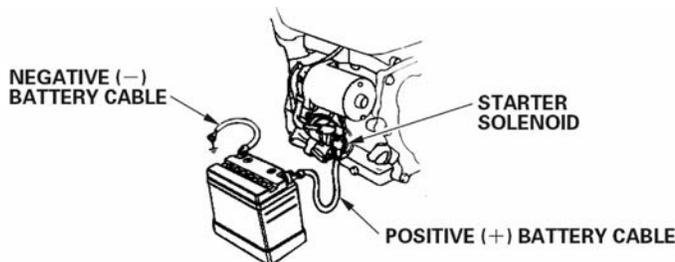

2. Connect the battery negative (-) cable to an engine mounting bolt, frame bolt, or other good engine ground connection.
3. Connect the battery positive (+) cable to the battery positive (+) terminal.
4. Connect the battery negative (-) cable to the battery negative (-) terminal.
5. Coat the terminals and cable ends with grease.

Remote Control Linkage

The throttle and choke control levers are provided with holes for optional cable attachment. The following illustrations show installation examples for a solid wire cable and for a flexible, braided wire cable. If using a flexible, braided wire cable, add a return spring as shown.

It is necessary to loosen the throttle lever friction nut when operating the throttle with a remotely-mounted control.

Models: 2541-0043 thru 2541-0046

REMOTE THROTTLE LINKAGE

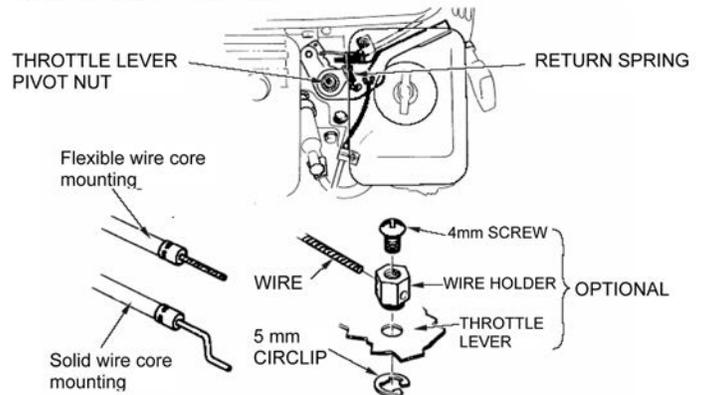

REMOTE CHOKE LINKAGE

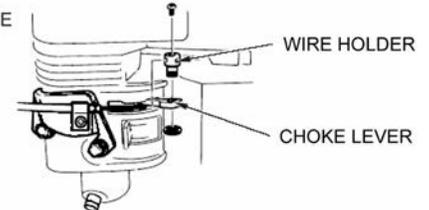

Technical & Consumer Information

Models: 2541-0047 thru 2541-0051

REMOTE THROTTLE LINKAGE

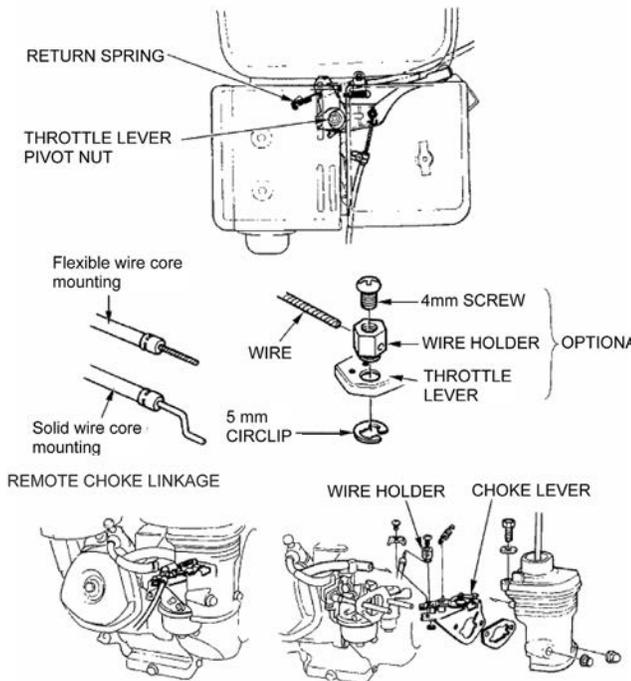

Carburetor Modification for High Altitude Operation

At high altitude, the standard carburetor air-fuel mixture will be too rich. Performance will decrease, and fuel consumption will increase. A very rich mixture will also foul the spark plug and cause hard starting. Operation at an altitude that differs from that at which this engine was certified, for extended periods of time, may increase emissions.

High altitude performance can be improved by specific modifications to the carburetor. If you always operate your engine at altitudes above 5,000 feet (1,500 meters), have your servicing dealer perform this carburetor modification. This engine, when operated at high altitude with the carburetor modifications for high altitude use, will meet each emission standard throughout its useful life.

Even with carburetor modification, engine horsepower will decrease about 3.5% for each 1,000-foot (300-meter) increase in altitude. The effect of altitude on horsepower will be greater than this if no carburetor modification is made.

NOTICE

When the carburetor has been modified for high altitude operation, the air-fuel mixture will be too lean for low altitude use. Operation at altitudes below 5,000 feet (1,500 meters) with a modified carburetor may cause the engine to overheat and result in serious engine damage. For use at low altitudes, have your servicing dealer return the carburetor to original factory specifications.

Oxygenated Fuels

Some conventional gasolines are being blended with alcohol or an ether compound. These gasolines are collectively referred to as oxygenated fuels. To meet clean air standards, some areas use oxygenated fuels to help reduce emissions.

If you use an oxygenated fuel, be sure it is unleaded and meets the minimum octane rating requirement.

Before using an oxygenated fuel, try to confirm the fuel's contents. Some areas require this information to be posted on the pump.

The following are the EPA-approved percentages of oxygenates:

ETHANOL – (ethyl or grain alcohol) 10% by volume. You may use gasoline containing up to 10% ethanol by volume.

Gasoline containing ethanol may be marketed under the name "Gasohol."

MTBE – (methyl tertiary butyl ether) 15% by volume. You may use gasoline containing up to 15% MTBE by volume.

METHANOL – (methyl or wood alcohol) 5% by volume. You may use gasoline containing up to 5% methanol by volume, as long as it also contains cosolvents and corrosion inhibitors to protect the fuel system. Gasoline containing more than 5% methanol by volume may cause starting and/or performance problems. It may also damage metal, rubber, and plastic parts of your fuel system.

If you notice any undesirable operating symptoms, try another service station, or switch to another brand of gasoline.

Fuel system damage or performance problems resulting from the use of an oxygenated fuel containing more than the percentages of oxygenates mentioned above are not covered under warranty.

Technical & Consumer Information

EMISSION CONTROL SYSTEM INFORMATION

Source of Emissions

The combustion process produces carbon monoxide, oxides of nitrogen, and hydrocarbons. Control of hydrocarbons and oxides of nitrogen is very important because, under certain conditions, they react to form photochemical smog when subjected to sunlight. Carbon monoxide does not react in the same way, but it is toxic.

This utilizes lean carburetor settings and other systems to reduce the emissions of carbon monoxide, oxides of nitrogen and hydrocarbons.

Tampering and Altering

Tampering with or altering the emission control system may increase emissions beyond the legal limit. Among those acts that constitute tampering are:

- Removal or alteration of any part of the intake, fuel or exhaust systems.
- Altering or defeating the governor linkage or speed-adjusting mechanism to cause the engine to operate outside its design parameters.

Problems that may Affect Emissions

If you are aware of any of the following symptoms, have your engine inspected and repaired by your servicing dealer.

- Hard starting or stalling after starting
- Rough idle
- Misfiring or backfiring under load
- Afterburning (backfiring)
- Black exhaust smoke or high fuel consumption

Replacement Parts

The emission control systems on your engine were designed, built. We recommend the use of genuine parts whenever you have maintenance done. These original-design replacement parts are manufactured to the same standards as the original parts, so you can be confident of their performance. The use of replacement parts that are not of the original design and quality may impair the effectiveness of your emission control system.

A manufacturer of an aftermarket part assumes the responsibility that the part will not adversely affect emission performance. The manufacturer or rebuilder of the part must certify that use of the part will not result in a failure of the engine to comply with emission regulations.

Maintenance

Follow the maintenance schedule. Remember that this schedule is based on the assumption that your machine will be used for its designed purpose. Sustained high-load or high-temperature operation, or use in unusually wet or dusty conditions, will require more frequent service.

Engine Tune-up

ITEM	SPECIFICATION
Spark plug gap	0.028-0.031 in (0.70-0.80 mm)
Valve clearance	IN: 0.15±0.02 mm (cold) EX: 0.20±0.02 mm (cold)
Other specifications	No other adjustments needed

CONSUMER INFORMATION

For technical assistance, contact the Hypro Technical/Application Department by phone at 1-800-PowerPro (800-769-3777) or by email at technical@hypropumps.com.

QUICK REFERENCE INFORMATION

Engine Oil	Type	SAE 10W-30, API SG or SH, for general use
	Capacity	2541-0043 thru 0046 0.6 L (0.63 qt) 2541-0047 thru 0051 1.1 L (1.2 qt)
Spark Plug	Type	LD - F7RTC or NGK – BPR6ES
	Gap	0.028 - 0.031 in (0.70 - 0.80 mm)
Carburetor	Idle speed	1400±150 rpm
Maintenance	Each use	Check engine oil. Check air filter.
	First 20 hours	Change engine oil.
	Subsequent	Refer to the maintenance schedule.

Specifications

Model	2541-0045	2541-0046	2541-0048	2541-0049	2541-0050	2541-0051
Shaft Type	3/4" keyed	5/8" threaded	1" keyed	1" keyed	1" threaded	1" threaded
Electric Start	no	no	no	yes	no	yes
Low Oil Sensor	yes	yes	yes	yes	yes	yes
Type	Single cylinder, 4-Stroke, Forced Air Cooling, OHV					
Maximum Power (kW/3600rpm)	4.85 (6.5 hp)		9.7 (13.0 hp)			
Rated Power (kW/3600rpm)	3.8 (5.1 hp)		8.3 (11.1 hp)			
Max. Torque (N·m/rpm)	13/3000 (9.6 ft lb)		26.5/3000 (19.6 ft lb)			
Engine Oil Capacity	0.60 L (0.63 qt)		1.1 L (1.2 qt)			
Fuel Tank Capacity	3.6 L (0.95 gal)		6.5 L (1.7 gal)			
Fuel Consumption (g/kW·h)	≤395					
Idle Speed	1400±150 rpm					
Speed Fluctuating Ratio	≤10%					
Noise(≤)	70db(A)		80db(A)			
Bore×Stroke (mm)	68×54		88×64			
Displacement (cc)	196		389			
Compression Ratio	8.5:1		8.1:1			
Lubricating Mode	Splash					
Starting Mode	Recoil start (Recoil start / Electric starting)					
Rotation	Anti-clockwise (from PTO side)					
Valve Clearance	Input valve : 0.10~0.15mm, Output valve : 0.15~0.20mm					
Spark Plug Clearance	0.7~0.8mm					
Igniting Mode	Transistorized Magneto Ignition					
Air Cleaner	Semi-dry, Oil-bath, Foam filter					
Dimension (Length) (mm)	312		405			
Dimension (Width) (mm)	376		450			
Dimension (High) (mm)	335		443			
Net weight (kg)	16(19)		31(34)			

Engine Replacement Parts

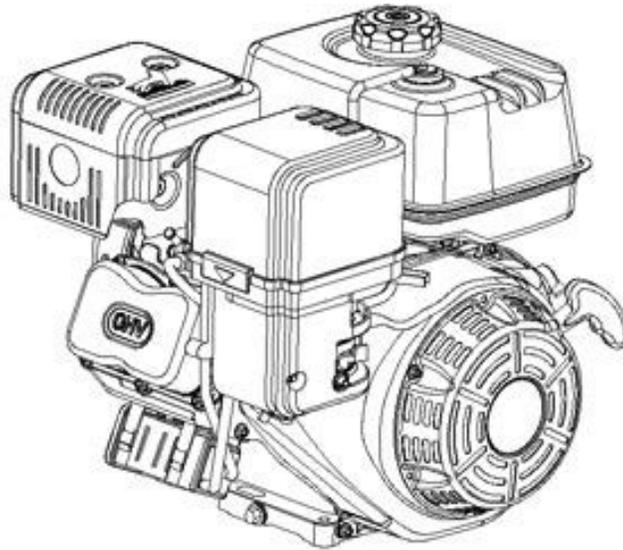

Model HY160 and HY200
HY160 - 2541-0043, 2541-0044
HY200 - 2541-0045, 2541-0046

Model HY270 and HY390
HY270 - 2541-0047
HY390 - 2541-0048, 2541-0049, 2541-0050, 2541-0051

Part Number	Description
2545-0030	Muffler w/Cover HY160/200
2545-0033	Air Cleaner Cover HY160/200
2545-0036	Air Cleaner Element HY160/200
2545-0039	Flywheel Shroud HY160/200
2545-0042	Recoil Assembly HY160/200
2545-0045	Fuel Cap PowerPro
2545-0046	Fuel Tank HY160/200
2545-0048	ON/OFF Switch HY160/200
2545-0050	Low Oil Sensor HY160/200
2545-0052	Oil Dipstick HY160/200
2545-0054	Ignition Module HY160/200
2545-0057	Carburetor HY160
2545-0058	Carburetor HY200
2545-0061	Engine Gasket Kit HY160/200
	Head Gasket HY160
	Head Gasket HY200
	Exhaust Pipe Gasket
	Crank Oil Seal (2)
	Crankcase Cover Gasket
	Valve Cover Gasket
	Carb Gaskets (4)

Part Number	Description
2545-0031	Muffler w/Cover HY270
2545-0032	Muffler w/Cover HY390
2545-0034	Air Cleaner Cover HY270
2545-0035	Air Cleaner Cover HY390
2545-0037	Air Cleaner Element HY270
2545-0038	Air Cleaner Element HY390
2545-0040	Flywheel Shroud HY270
2545-0041	Flywheel shroud HY390
2545-0043	Recoil Assembly HY270
2545-0044	Recoil Assembly HY390
2545-0045	Fuel Cap PowerPro
2545-0047	Fuel Tank HY270/390
2545-0049	ON/OFF Switch HY270/390
2545-0051	Low Oil Sensor HY270/390
2545-0053	Oil Dipstick HY270/390
2545-0055	Ignition Module HY270
2545-0056	Ignition Module HY390
2545-0059	Carburetor HY270
2545-0060	Carburetor HY390

2545-0062	Engine Gasket Kit HY270/390
	Head Gasket HY270
	Head Gasket HY390
	Exhaust Pipe Gasket
	Crank Oil Seal HY270 (2)
	Crank Oil Seal HY390 (2)
	Crank Cover Gasket HY270
	Crank Cover Gasket HY390
	Valve Cover Gasket
	Carb Gaskets (5)

Wiring Diagrams

ENGINE SWITCH

	IG	E	ST	BAT
OFF	○—○			
ON				
START			○—○	

Bl	BLACK	Br	BROWN
Y	YELLOW	R	RED
W	WHITE	G	GREEN

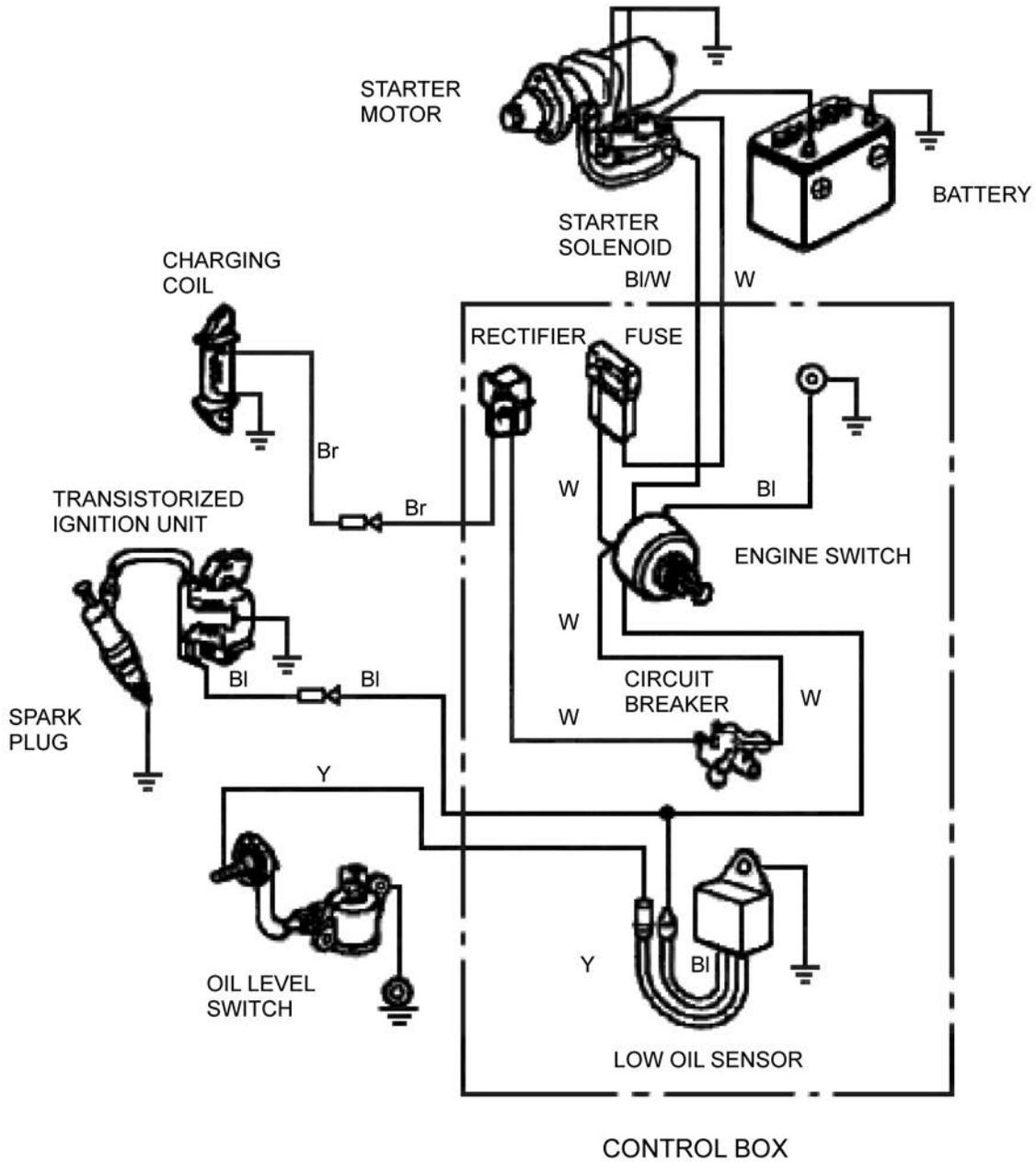

Wiring Diagrams

Engine Type with Oil Alert and without Electric Starting

BI	BLACK
Y	YELLOW
G	GREEN

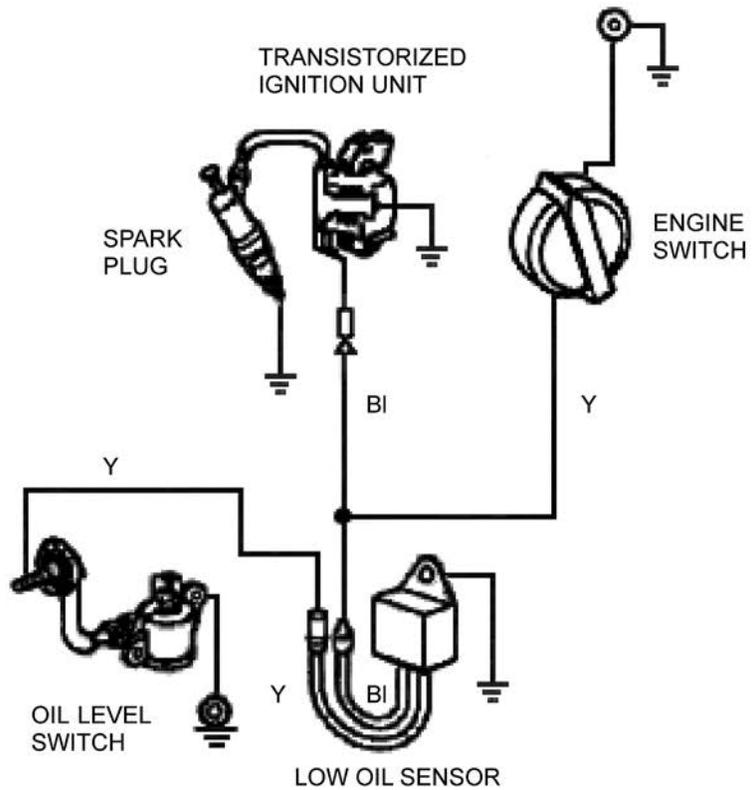

Optional Parts

BATTERY

Use a battery rated at 12V, 18Ah or more.

NOTICE

Do not reverse polarity. Serious damage to the engine and/or battery may occur.

⚠ WARNING

A battery can explode if you do not follow the correct procedure, seriously injuring anyone nearby. Keep all sparks, open flames and smoking materials away from the battery.

Check the electrolyte level to be sure that it is between the marks on the case. If the level is below the lower mark, remove the caps and add distilled water to bring the electrolyte level to the upper mark. The cells should be equally full.

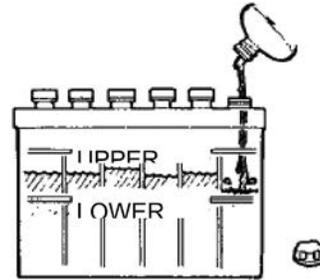

Emissions Warranty

California, U.S. EPA, and Pentair Emissions Control Warranty Statement Your Warranty Rights and Obligations

The California Air Resources Board, U.S. EPA and Pentair are pleased to explain the emissions control system warranty on your engine/equipment. In California, new small off-road engines and large spark ignited engines less than or equal to 1.0 liter must be designed, built, and equipped to meet the State's stringent anti-smog standards. Pentair must warrant the emissions control system on your PowerPro™ engine/equipment for the periods of time listed below provided there has been no abuse, neglect, or improper maintenance of your engine or equipment. Your emissions control system may include parts such as the carburetor or fuel injection system, fuel tank, ignition system, and catalytic converter. Also included may be hoses, belts, connectors, sensors and other emissions-related assemblies. Where a warrantable condition exists, Pentair will repair your engine/equipment at no cost to you including diagnosis, parts and labor.

California:

Pentair PowerPro™ engines available for sale in California can be identified by part number (2541 prefix) and engine emissions label. These models comply with CARB emission standards.

Other States and U.S. territories:

In other areas of the United States, Pentair PowerPro™ engines can be identified by part number (2543 prefix) and engine emissions label. These models comply with U.S. EPA emission standards and are not available for sale in California.

Manufacturer's Warranty Coverage:

Small off-road engines and large spark ignited engines less than or equal to 1.0 liter are warrant for two years. If any emissions-related part on your engine/equipment is defective, the part will be repaired or replaced by Pentair.

Owner's Warranty Responsibilities:

As the engine/equipment owner, you are responsible for the performance of the required maintenance listed in your owner's manual. Pentair recommends that you retain all receipts covering maintenance on you engine/equipment, but Pentair cannot deny warrant solely for the lack of receipts or your failure to ensure the performance of all scheduled maintenance. As the engine/equipment owner, you should however be aware that Pentair may deny you warranty coverage if your engine/equipment or a part has failed due to abuse, neglect, improper maintenance or unapproved modifications. You are responsible for presenting you engine/equipment to a Pentair distribution center, servicing dealer, or other equivalent entity, as applicable, as soon as a problem exists. The warranty repairs should be completed in a reasonable amount of time, not to exceed 30 days. If you have any questions regarding your warranty rights and responsibilities, you should contact Pentair at 800-PowerPro (800-769-3777) or hypro.service@pentair.com

Pentair Emissions Control Warranty Provisions

The following are specific provisions relative to your Emissions Control Warranty Coverage. It is in addition to the Pentair engine warranty for non-regulated engines found in the Operator's Manual.

1. Warranted Emissions Parts

Coverage under this warranty extends only to the parts listed below (the emissions control systems parts) to the extent these parts were present on the engine purchased.

a. Fuel Metering System

- Cold start enrichment system (soft choke)
- Carburetor and internal parts
- Fuel pump
- Fuel line, fuel line fittings, clamps
- Fuel tank, cap and tether
- Carbon canister

b. Air Induction System

- Air cleaner
- Intake manifold
- Purchase and vent line

c. Ignition System

- Spark plug(s)
- Magneto ignition system

d. Catalyst System

- Catalytic converter
- Exhaust manifold
- Air injection system or pulse valve

e. Miscellaneous Items Used in Above Systems

- Vacuum, temperature, position, time sensitive valves and switches
- Connectors and assemblies

2. Length of Coverage

For a period of two years from date of original purchase, Pentair warrants to the original purchaser and each subsequent purchaser that the engine is designed, built, and equipped so as to conform with all applicable regulations adopted by the Air Resources Board; that it is free from defects in material and workmanship that could cause the failure of a warranted part; and that it is identical in all material respects to the engine described in the manufacturer's application for certification. The Warranty period begins on the date the engine is originally purchased.

The warranty on emissions related parts is as follows:

- Any warranted part that is scheduled for replacement as required maintenance in the owner's manual supplied, is warranted for the warranty period stated above. If any such part fails during the period of warranty coverage, the part will be repaired or replaced by Pentair at no charge to the owner. Any such part repaired or replaced under the warranty will be warranted for the remaining warranty period.
- Any warranted part that is scheduled only for regular inspection in the owner's manual supplied, is warranted for the warranty period stated above. Any such part repaired or replaced under warranty will be warranted for the remaining warranty period.
- Any warranted part that is scheduled for replacement as required maintenance in the owner's manual supplied, is warranted for the period of time prior to the first scheduled replacement point for that part. If the part fails prior to the first scheduled replacement, the part will be repaired or replaced by Pentair at no charge to the owner. Any such part repaired or replaced under warranty will be warranted for the remainder of the period prior to the first scheduled replacement point for the part.
- Add on or modified parts that are not exempted by the Air Resources Board may not be used. The use of any non-exempted add on or modified parts by the owner will be grounds for disallowing a warranty claim. The manufacturer will not be liable to warrant failures of warranted parts caused by the use of a non-exempted add on or modified part.

3. Consequential Coverage

Coverage shall extend to the failure of any engine components caused by the failure of any warranted emissions parts.

4. Claims and Coverage Exclusions

Warranty claims shall be filed according to the provisions of the Pentair engine warranty policy. Warranty coverage does not apply to failures of emissions parts that are not original equipment Pentair parts or to parts that fail due to abuse, neglect, or improper maintenance as set forth in the Pentair engine warranty policy. Pentair is not liable for warranty coverage of failures of emissions parts caused by the use of add-on or modified parts.

Look for Relevant Emissions Durability Period and Air Index Information On Your Small Off-Road Engine Emissions Label

Engines that are certified to meet the California Air Resources Board (CARB) small off-road Emissions Standard must display information regarding the Emissions Durability Period and the Air Index. Pentair makes this information available to the consumer on our emissions labels. The engine emissions label will indicate certification information.

The Emissions Durability Period describes the number of hours of actual running time for which the engine is certified to be emissions compliant, assuming proper maintenance in accordance with the Operating and Maintenance Instructions. The following categories are used:

Moderate:

Engine is certified to be emissions compliant for 125 hours of actual engine running time.

Intermediate:

Engine is certified to be emissions compliant for 250 hours of actual engine running time.

Extended:

Engine is certified to be emissions compliant for 500 hours of actual engine running time.

For example, a typical gas engine powered transfer pump is used 20-25 hours per year. Therefore, the Emissions Durability Period of an engine with a Moderate rating would equate to 5-6 years.

Pentair's PowerPro™ engines are certified to meet the United States Environmental Protection Agency (USEPA) Phase 3 emissions standards. For Phase 3 certified engines, the Emissions Compliance Period referred to on the Emissions Compliance label indicates the number of operating hour for which the engine has been shown to meet Federal emissions requirements.

For engine less than 225 cc displacement.

Category C = 125 hours, Category B = 250 hours, Category A = 500 hours

For engines of 225 cc or more displacement.

Category C = 250 hours, Category B = 500 hours, Category A = 1000 hour

Limited Warranty on PowerPro Gasoline Engines

Hypro warrants to the original purchaser of its PowerPro gasoline engine to be free from defects in material and workmanship under normal use for the period of one (1) year from the date of purchase. This warranty does not cover freight damage, normal wear and tear, or damage caused by misapplication, lack of routine maintenance, negligence, alterations, or repair that affects the performance or reliability of the engine (see limitations and exclusions listed below). The repair or replacement of any part or parts under this Limited Warranty shall not extend the terms of the warranty beyond the original warrantable period.

THIS WARRANTY IS EXCLUSIVE. HYPRO MAKES NO OTHER WARRANTY, EXPRESS OR IMPLIED, INCLUDING BUT NOT LIMITED TO ANY WARRANTY OF MERCHANTABILITY OR FITNESS FOR A PARTICULAR PURPOSE.

Hypro's obligation under this warranty is, at Hypro's option, to either repair or replace free of charge, any part, or parts of the engine upon return of the entire product to the Hypro factory in accordance with the return procedures set forth below. **THIS IS THE EXCLUSIVE REMEDY FOR ANY BREACH OF WARRANTY.**

LIMITATIONS AND EXCLUSIONS: This Limited Warranty shall not apply to:

1. Bent or broken crankshaft or damage caused by vibration related to a bent or broken crankshaft. Also, damage caused by loose engine mounting bolts or improper or imbalanced accessories.
2. Repairs required because of prolonged storage including damage caused by old or contaminated fuel in the fuel tank, fuel lines or carburetor, sticky valves or corrosion and rust of engine parts.
3. Repair required due to overheating. Common causes of overheating are clogged or damaged flywheel, fan, inlet air passages, cooling fins or air shrouds.
4. Damaged or broken parts caused by low oil levels or dirty or improper grade of motor oil.
5. Engine tune-ups and normal maintenance services including, but not limited to, fuel and lubricating oil, valve adjustments and normal replacement of service items.
6. Dirt or grit related wear caused by improper air cleaner maintenance. The damages include but not limited to worn pistons, piston rings, cylinders, valves, valve guides, carburetors and other internal components.
7. Engines that have been serviced or repaired with parts or components not manufactured or approved by Hypro.
8. Engines that have been serviced by someone other than Hypro or its dealerships.
9. Instances when normal use has worn out the component or a engine without any signs of breakage or defects.

IN NO EVENT SHALL HYPRO BE LIABLE FOR ANY INCIDENTAL OR CONSEQUENTIAL DAMAGES OF ANY KIND, WHETHER FOR BREACH OF ANY WARRANTY, FOR NEGLIGENCE, ON THE BASIS OF STRICT LIABILITY, OR OTHERWISE.

Return Procedures

All engines must be flushed of any flammable liquids before being shipped* to Hypro for service or warranty consideration.

For technical or application assistance, call the **Hypro Technical/Application number: 1-800-PowerPro (800-769-3777)**, or send an email to: **technical@hypropumps.com**. To obtain service, warranty assistance, or a Return Merchandise Authorization number, call the **Hypro Service and Warranty number: 1-800-468-3428**; or send a fax to the **Hypro Service and Warranty FAX: (651) 766-6618**.

Be prepared to give Hypro full details of the problem, including the following information:

1. Model number, date and the company from whom you purchased your PowerPro engine.
2. Approximate number of hours on the engine.
3. In what application the engine is currently being used.
4. Maintenance that has been done on the engine prior to failure.

Hypro may request additional information to help determine the cause of failure. **Contact the factory to receive a return material authorization number (RMA) before sending the product. The customer is responsible for all transportation charges related to warranty work. If found warrantable, returned product(s) will be sent back to the customer at Hypro's expense. Non-warrantable items will be evaluated and an estimate of repair will be sent to the customer.**

Please send products back prepaid to:

HYPRO / PENTAIR
Attention: Service Department
375 Fifth Avenue NW
New Brighton, Minnesota 55112

* Carriers, including U.S.P.S., airlines, UPS, ground freight, etc., require specific identification of any hazardous materials being shipped. Failure to do so may result in a substantial fine and/or prison term. Check with your shipping company for specific instructions.



375 Fifth Avenue NW • New Brighton, MN 55112
Phone: (651) 766-6300 • 800-424-9776 • Fax: 800-323-6496
www.hypropumps.com



APPENDIX II

Hypro Diaphragm Pump Manual



DIAPHRAGM PUMPS

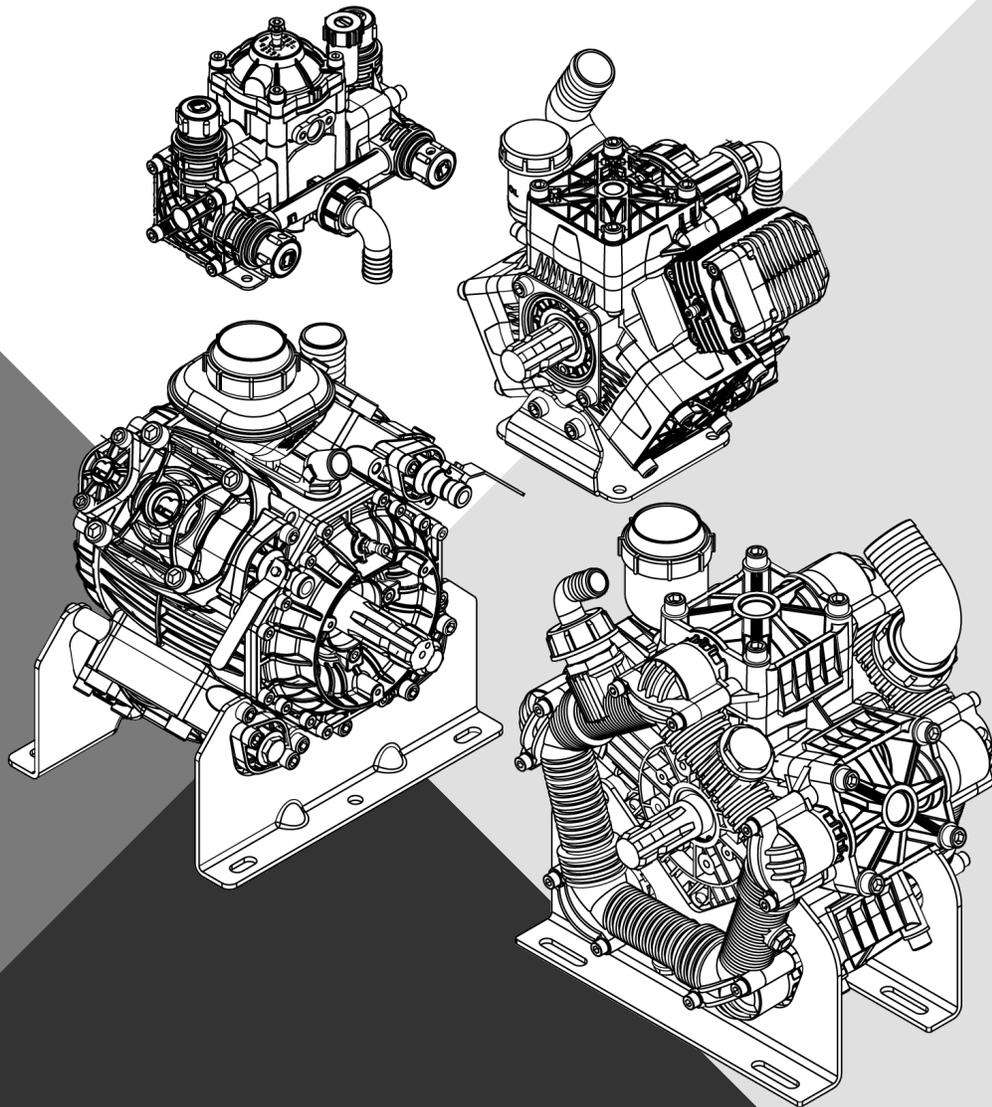

INSTALLATION AND OPERATION MANUAL

pentair.com

TABLE OF CONTENTS

Safety Information	3
General Information	5
Installation and Operations	6
Maintenance	8
Low Pressure 15 Bar	
Performance & Specifications	10
Installation	11
Replacement Parts List.....	12
Medium Pressure 20-40 Bar	
Performance & Specifications	18
Installation	20
Replacement Parts List.....	24
High Pressure 50 Bar	
Performance & Specifications	32
Installation	33
Replacement Parts List.....	34
Troubleshooting.....	38
Warranty.....	40

SAFETY INFORMATION

Save these instructions: This manual contains important instructions that should be followed during installation, operation, and maintenance of the product.

SAFETY SYMBOLS

⚠ CAUTION Caution is used to indicate the presence of a hazard, which will or may cause minor injury or property damage if the notice is ignored

⚠ WARNING Warning denotes that a potential hazard exists and indicates procedures that must be followed exactly to either eliminate or reduce the hazard, and to avoid serious personal injury, or prevent future safety problems with the product.

⚠ DANGER Danger is used to indicate the presence of a hazard that will result in severe personal injury, death, or property damage if the notice is ignored.

⚠ This is the safety alert symbol. When you see this symbol on your pump or in this manual, look for one of the following signal words and be alert to the potential for personal injury.

The word **NOTE** indicates special instructions that are important but not related to hazards

CALIFORNIA PROPOSITION 65 WARNING

⚠ WARNING This product and related accessories contain chemicals known to the State of California to cause cancer, birth defects or other reproductive harm.

PACKAGING INSPECTION

When the unit is received, look for any product damage as you unpack the item. If any damage is present or parts are missing, do not attempt to operate pump. Use this manual to determine that all parts are properly installed. If you are in doubt, do not operate the pump.

Before you start first, refer to local codes to ensure safety and regulatory compliance.

GENERAL SAFETY

Carefully read and follow all safety instructions in this manual and on the unit itself. Failure to comply with the safety instructions could result in personal injury and/or property damage!

Know the pump application, limitations, and potential hazards. Follow all applicable local and state codes and regulations.

Keep safety labels in good condition, replacing any missing or damaged labels.

Personal Safety:

- ◆ Wear safety glasses at all times when working with pumps.
- ◆ Keep work area clean, uncluttered and properly lighted. Replace all unused tools and equipment.
- ◆ Keep visitors at a safe distance from work area.
- ◆ Make workshop child-proof with padlocks, master switches, and by removing starter keys.

⚠ DANGER Do not pump flammable or explosive fluids such as gasoline, fuel oil, kerosene, etc. Do not use in explosive atmospheres. Do not pump asphalt sealer, roofing compounds, concrete sealers, or any two-step curing products. The pump should only be used with liquids compatible with the pump materials. Failure to follow this notice can result in severe personal injury and/or property damage and will void the product warranty.

Never use your hand to check the condition of hydraulic lines or hoses. If hydraulic fluid penetrates the skin, get medical attention immediately. Failure to get proper medical attention may result in loss of limb or life. The safest way to check hydraulic lines is by holding a piece of cardboard next to the hydraulic line or hose.

⚠ WARNING The sound pressure level of the pump may exceed 80dBA. Observe all safety precautions when operating the pump within close proximity for extended periods by wearing hearing protectors. Extended exposure to elevated sound levels will result in permanent loss of hearing acuteness, tinnitus, tiredness, stress, and other effects such as loss of balance and awareness.

Verify that pump shaft rotates freely prior to engaging the pump drive.

SAFETY INFORMATION

- ◆ Do not pump at pressures higher than the maximum recommended pressure.
- ◆ Operate the pump between a temperature ranges of 45° to 140°F [7° to 60°C].
- ◆ Make certain that the power source conforms to the requirements of your equipment.
- ◆ Provide adequate protection in guarding around the moving parts such as shafts and pulleys.
- ◆ Disconnect the power before servicing.
- ◆ Release all pressure within the system before servicing any component.
- ◆ Drain all liquids from the system before servicing.
- ◆ Secure the discharge line before starting the pump. An unsecured discharge line may whip, resulting in personal injury and/or property damage.
- ◆ Check all hoses for weak or worn condition before each use. Make certain that all connections are tight and secure.
- ◆ Periodically inspect the pump and the system components. Keep free of debris and foreign objects.
- ◆ Perform routine maintenance as required (see maintenance).
- ◆ When wiring an electrically driven pump, follow all electrical and safety codes, as well as the most recent National Electrical Code (NEC) and the Occupational Safety and Health Act (OSHA) requirements.
- ◆ Use only pipe, hose, and hose fittings rated for maximum rated pressure of the pump or the pressure at which the pressure relief valve is set at. Do not use used pipe.
- ◆ Do not use these pumps for pumping water or other liquids for human or animal consumption.
- ◆ Do not pressure feed pump inlet.
- ◆ Do not touch an operating motor. Modern motors can operate at high temperatures.
- ◆ Do not handle pump or pump motor with wet hands or when standing on wet or damp surface, or in water.

HAZARDOUS SUBSTANCE ALERT

1. Always drain and flush pump before servicing or disassembling for any reason (see instructions).
2. Always drain and flush pumps prior to returning unit for repair.
3. Never store pumps containing hazardous chemicals.
4. Before returning pump for service/repair, drain out all liquids and flush unit with neutralizing liquid. Then, drain the pump. Attach tag or include written notice certifying that this has been done. Please note that it is illegal to ship or transport any hazardous chemicals without United States Environmental Protection Agency Licensing

GENERAL INFORMATION

DESCRIPTION AND USES

Hypro Diaphragm pumps are intended for creating or boosting dynamic pressure for non-food purposes with clean and approved fluids in a watery solution which are compatible with the materials of the pump at temperatures between 45° to 140°F [7° to 60°C].

INTENDED USES

Hypro pressure diaphragm pumps are recommended for spraying herbicides, pesticides, liquid fertilizers, and many other hard to handle fluids. Low-cost maintenance and almost wear-free operation make these pumps ideal for a wide variety of spraying jobs. Pressure and output are designed for optimum performance of small to large-sized sprayers.

Any uses outside of those specified in this manual are considered misuses and are prohibited. Contact Hypro technical service with any questions regarding specific acceptable uses.

The pump cannot be used with:

- ◆ Watery solutions whose viscosity and density exceed those of water.
- ◆ Chemical solutions for which compatibility with the materials the pump is made is not known.
- ◆ Sea water or water with a high concentration of salt.
- ◆ Fuels and lubricants of all kinds and types.
- ◆ Inflammable liquids or liquefied gases.
- ◆ Food-grade liquids.
- ◆ Solvents and diluents of all kinds and types.
- ◆ Paints of all kinds and types.
- ◆ Liquids at temperatures lower than 7°C or higher than 60°C.
- ◆ Liquids containing granules or solids in suspension.
- ◆ The pump must not be used in places where there are particular conditions, such as corrosive or explosive atmospheres, for example.

MISUSES

Hypro centrifugal pumps are designed to operate effectively within the specified speed, pressure and environmental ranges. Going outside of these ranges will void the warranty and could cause damage to property, serious injury, or death.

- ◆ Do not run the pump faster than the maximum specified speed.
- ◆ Do not run the pump higher than the maximum specified pressure.
- ◆ Do not run pumps when the liquid has exceeded the maximum or minimum temperature limit.
- ◆ Do not pump non-approved liquids.
- ◆ Do not pump water or other liquids for human consumption.
- ◆ Do not operate any Hypro pump under the influence of drugs or alcohol.
- ◆ Do not run the pump dry.
- ◆ Do not run the pump hydraulic motor higher than the specified RPM, pressure or flow.
- ◆ Do not run the pump without adequate suction filter.

INSTALLATION AND OPERATION

PUMP PLUMBING

Use only pipe, fittings, accessories, hose, etc. rated for the maximum pressure rating of the pump.

1. Always mount pump with oil sight tube in upright position (See Figure 1).
2. The proper selection of hose type and size is vital to optimal performance
 - ◆ Use good quality inlet hose, compatible with the fluids being pumped and with good elasticity to reduce inlet water hammer or pulsation. Be sure that hose is not too rigid but capable of operating at low vacuums without collapsing. The diameter of the inlet hose should be at least that of the pump inlet port size and preferably one size larger if the inlet line is longer than 6 feet [1.8meters].
 - ◆ Use only approved high pressure hose on the discharge side of pump.
3. Most ports are provided with hose barb connections. Use good quality hose clamps and tighten them securely.
4. It is recommended to install strainer of 32 Mesh size having double flowrate of the pump at the suction side, to prevent diaphragm failures.

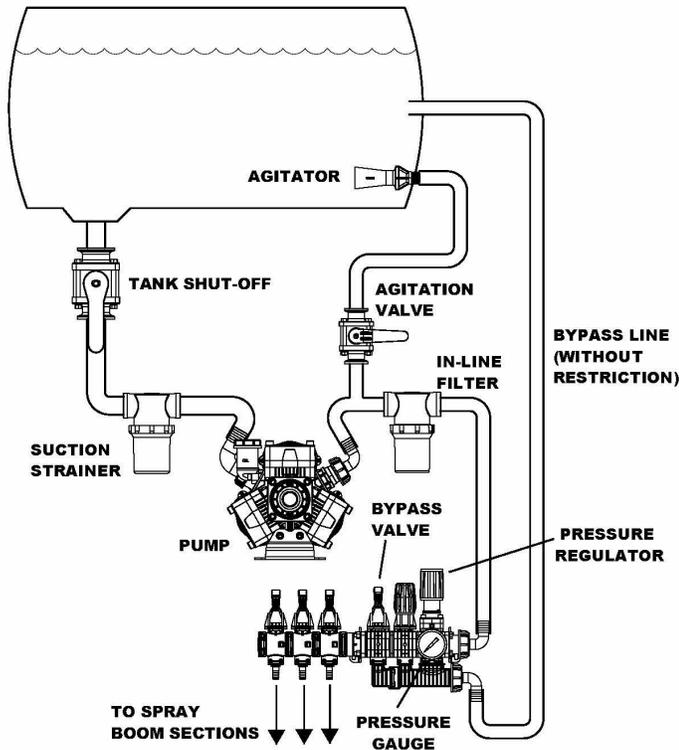

FIGURE 1

SHAFT ADAPTER KIT INSTALLATION

Order the appropriate shaft kit according to the chart on Spec Sheet.

1. Mount shaft adapter (Ref. 1A for 9915-KIT1201, Ref 1B for 9915-KIT1202 and Ref. 1B for 9915-KIT1203) onto the pump shaft and secure with 3 bolts (Ref. 2) and 3 washers (Ref. 3).
2. Mount pump/base assembly securely to prevent movement.

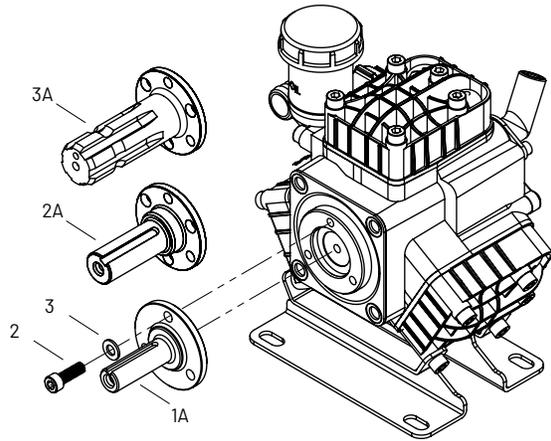

FIGURE 2

INSTALLATION AND OPERATION

OPERATION

1. Before start up check that oil is halfway up to the clear oil sight tube. If necessary, fill to the correct level with Hypro oil (part number 2160-0038). Hypro oil is a specially formulated, high-grade, non-detergent, SAE 30 weight oil formulated to prolong pump life.
2. Make sure the suction hose barb is tightly screwed onto the suction union and that there are no air leaks on the inlet side of the pump.
3. Check the charge pressure on the pulsation dampener before starting the pump. The pressure is checked with a standard automotive air gauge. The pressure should be at approximately 20% of the maximum pressure that you will be operating the pump at. Exercise caution when checking pressure to avoid losing pre-charge.
4. The relief valve bypass port should be connected back to the liquid tank without restrictions. Do not hook bypass line back to the inlet port or inlet hose.
5. Allow the pump to start under low pressure by removing restrictions on the outlet of the pump. The restriction on the pump is removed by rotating the Pressure Release knob on the control unit, fully toward bypass arrow direction.
6. Check oil level daily while pump is running. Start the pump and let it run for approximately one minute at low pressure. Adjust Pressure Release knob to run pump at operating pressure and check the oil sight tub level again to be sure the oil level is correct. Add Hypro oil if necessary.
7. Adjust the pump to the desired pressure by changing the relief valve setting on the control unit, relief valve or unloader. All the outlet valve must be closed as shown in Figure 3.

First back out the pressure regulator adjustment knob to zero. Then rotate the Pressure Release knob to Pressure arrow direction. Adjust the pressure by rotating the relief valve adjustment knob to the desired pressure.

For all discharge hoses, use hose with an operating pressure rating equal to or greater than the maximum pressure rating of the pump. High pressure clamping should be used on all outlet hose connections.

CAUTION The bypass return outlet on all control units must be connected directly to the tank without restrictions or ball valves.

WARNING Always wear safety goggles when working with spring-loaded fasteners or devices.

WARNING During the first step, you are strongly advised to start the pump with the regulating valve knob turned to 0 pressure and with the lever in the by-pass position. Maintain this configuration for a couple of minutes so as to lubricate the internal components of the pump and allow the diaphragms to set in position before the pressure is increased.

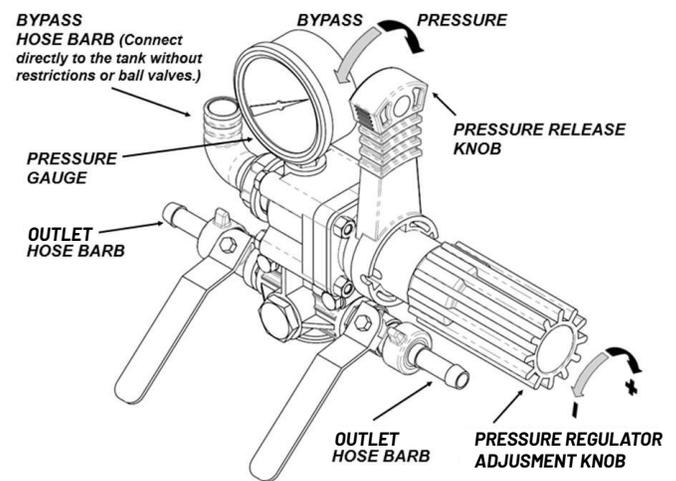

FIGURE 3

MAINTENANCE

MAINTENANCE SCHEDULE

REGULAR SERVICE PERIOD Performed at every indicated month or operating hour interval, whichever comes first.		First Use	Each Use	First month or 40 hours	Every 3 months or 500 hours	Every 6 months or 1000 hours
Crankcase Oil	Check Level	X	X			
	Replace			X	X	
Gearbox Oil	Check Level	X	X			
	Replace			X	X	
Pulsation Dampener Pressure (in models with dampeners)	Set to 20% of working PSI	X				
	Replace			X	X	
Diaphragms	Replace				X	
Valves	Check				X	
	Replace					X
O-rings	Check				X	
	Replace					X

MAINTENANCE INSTRUCTIONS

1. After usage, flush the pump with clean water.
2. Hypro diaphragm pumps come with oil in the crankcase. Hypro recommends changing oil after 40 hours of break-in operation and every three months or 500 hours, whichever comes first. Use Hypro oil (part number 2160-0038). Hypro oil is a specially formulated, high-grade, non-detergent, SAE 30 weight oil formulated to prolong pump life.

To drain the oil:

1. Remove the drain plug and the oil sight glass covers, and rotate shaft until the oil stops flowing out. Re-install the drain plug.
2. For DP252 and DP302 Series, Remove the oil fill cap, turn the pump upside down and rotate the shaft until oil stops flowing out
3. To fill the pump with oil, slowly pour oil into sight tube while turning the pump shaft. Turning the pump shaft purges all the air out of the crankcase. Always change oil when replacing diaphragms.
4. For winter storage or if a freezing condition will be countered, flush the pump with a 50/50 mixture of water and antifreeze.

CAUTION Fill oil to proper level in sight glass. Always make sure all the air is purged out of crankcase prior to operating.

VALVE REPLACEMENT

Occasionally debris may cause improper seating of the valves or damage to the O-rings. To check for this problem, follow these steps.

Remove the pump manifolds or valve retainer. With removal of that, the valves can easily be removed and inspected for debris and wear. Replace valves, O-rings and manifolds.

MAINTENANCE

DIAPHRAGM REPLACEMENT

Change diaphragms every 500 hours or three months, whichever comes first.

1. Drain oil from crankcase as instructed previously.
2. Remove pump head bolts and heads.
3. Remove the bolt securing the diaphragm (See Figure 4).
4. Remove the old diaphragm and the washer (See Figure 4).
5. Install a new diaphragm. Then turn the crankshaft to bring the piston to its mid-stroke and seat the diaphragm into the sleeve groove.
6. Install the washer and bolts removed in steps 3 and 4.
7. Replace the pulsation dampener diaphragm by first bleeding the air from the dampener. Remove the bolts from the dampener cover and replace the diaphragm. Reassemble the cover in place and charge the dampener to 20% of the operating pressure.
8. Refill the crankcase with Hypro oil (part number 2160-0038). Rotate the shaft to distribute the oil, and fill to proper level.

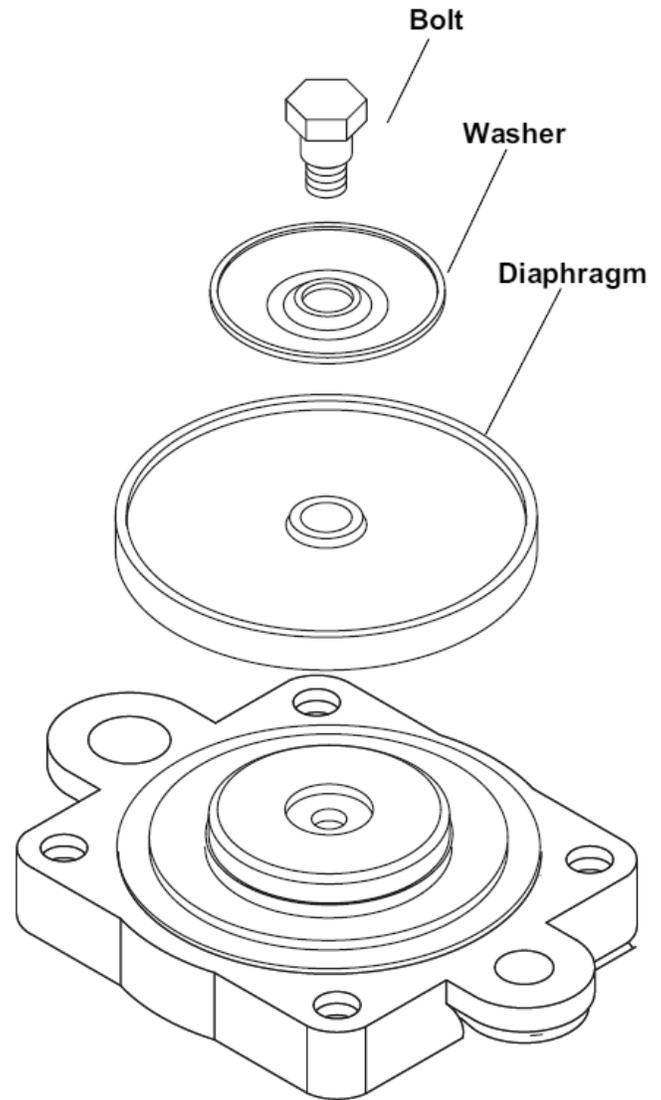
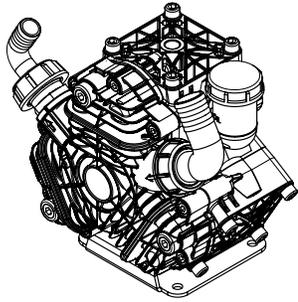
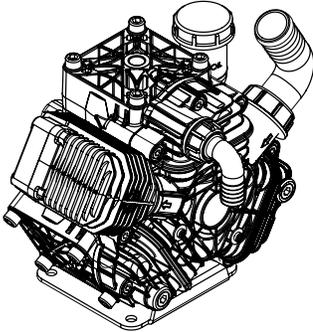

FIGURE 4

DIAPHRAGM PUMP: LOW PRESSURE RANGE 15BAR



Model Number	"Max. Flow USGPM [LPM]"	"Max. Pressure PSI [BAR]"	"Max. Speed RPM"	"Power HP [KW]"	No. of Diaphragm
9915-DP803	21.7 [82]	218 [15]	550	3.2 [2.4]	3



Model Number	"Max. Flow USGPM [LPM]"	"Max. Pressure PSI [BAR]"	"Max. Speed RPM"	"Power HP [KW]"	No. of Diaphragm
9915-DP1003	26.8 [102]	218 [15]	550	4.0 [3.0]	3

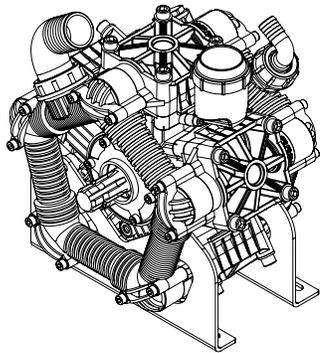

Model Number	"Max. Flow USGPM [LPM]"	"Max. Pressure PSI [BAR]"	"Max. Speed RPM"	"Power HP [KW]"	No. of Diaphragm
9915-DP2505	63.9 [242]	218 [15]	550	9.5 [7.1]	5

CONTROL UNITS

Control units are available for easy flow and pressure control of your sprayer system. These units include a manual dump valve and adjustable pressure relief valve to control pressure, a liquid-filled pressure gauge to monitor pressure, and shut-off valves to control flow. Control unit 9915-KIT1004 and 9915-KIT1005 can be remote mounted. Refer to the adjoining chart to select the proper control unit for your pump.

Oil Capacity: Oil crankcase capacities are approximate. Fill oil to proper level in sight glass. Always make sure all the air is purged out of crankcase prior to operating

Crankcase Oil Capacity	
Pump Model Series	"Capacity oz. [Litre]"
DP803	24 [0.7]
DP1003	24 [0.7]
DP2505	110 [3.25]

Control Unit Model Number	"Max. Flow USGPM [LPM]"	"Max. Pressure PSI [BAR]"	Pump Model
9915-KIT1004	42 [160]	290 [20]	DP803/DP1003
9915-KIT1005	69 [260]	218 [15]	DP2505

LOW PRESSURE 15 BAR PERFORMANCE AND SPECIFICATIONS

CONTROL UNIT KIT INSTALLATION

The control units are designed for control of pressure and flow rate. Use appropriate model (as specified in chart on page 10) to use with particular pump model and pressure/flow ranges.

NOTE: Hypro recommends a blue thread locking compound on all threaded fasteners that do not require lock washers.

Remote Mounting

1. Locate control unit at desired position with mounting holes provided and secure with the bolts and nuts.
2. Use the high pressure hose to connect pump discharge port hose barb to the control unit inlet port.
3. Connect the bypass hose to the bypass hose barb, then run it unrestricted to the supply tank.
4. Connect the desired number of high pressure hoses to the outlet ports on the control valve. Unused Ports can be shut off with ball valves provided.

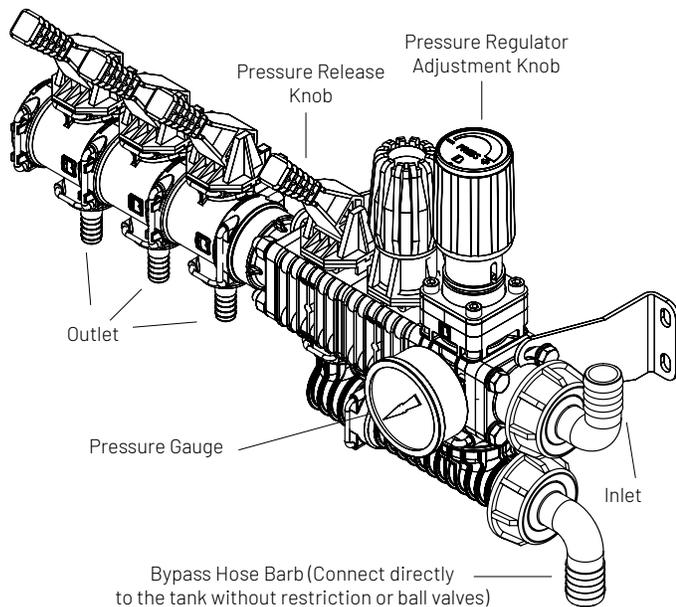

FIGURE 5: MODEL 9915-KIT1004

For all discharge hoses, use hose with an operating pressure rating equal to or greater than the maximum pressure rating of the pump. High pressure clamping should be used on all outlet hose connections.

WARNING Always wear safety goggles when working with spring-loaded fasteners or devices.

WARNING During the first step, you are strongly advised to start the pump with the regulating valve knob turned to 0 pressure and with the lever in the by-pass position. Maintain this configuration for a couple of minutes so as to lubricate the internal components of the pump and allow the diaphragms to set in position before the pressure is increased.

The restriction on the pump is removed by rotating the Pressure Release knob on the control unit, fully toward bypass arrow direction. First back out the pressure regulator adjustment knob to zero. Then rotate the Pressure Release knob to Pressure arrow direction. Adjust the pressure by rotating the relief valve adjustment knob to the desired pressure

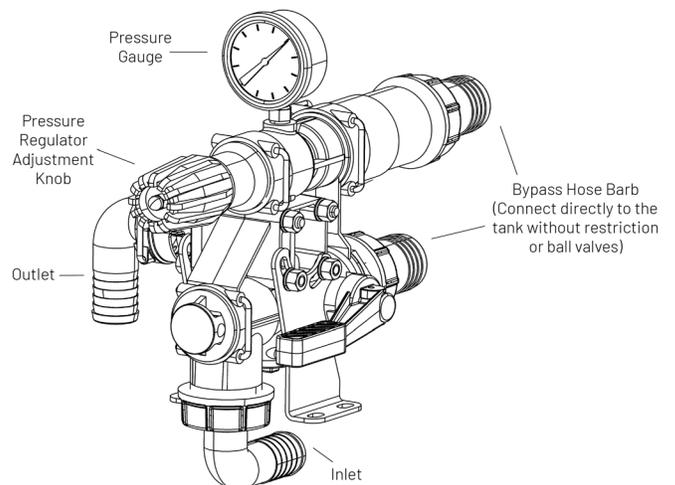

FIGURE 6: MODEL 9915-KIT1005

LOW PRESSURE 15 BAR REPLACEMENT PARTS

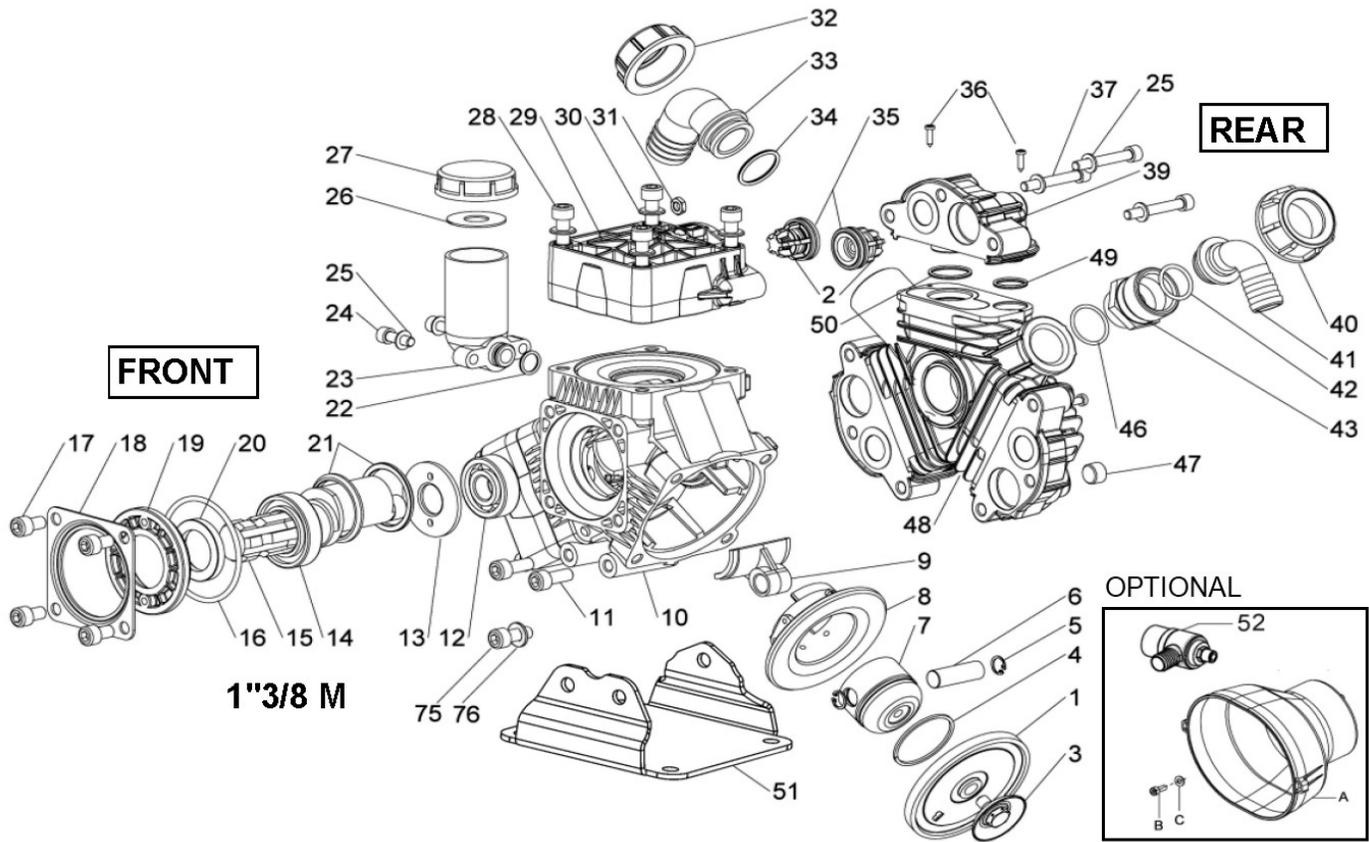

FIGURE 7: MODEL DP803

LOW PRESSURE 15 BAR REPLACEMENT PARTS

TORQUE CHART DP803

REF. No.	Qty.	N-m	ft.Lbs
3	3	25	18.5
43	1	20	14.8
47	3	"5 (LOXEAL 55-14)"	"3.7 (LOXEAL 55-14)"
24	2	5	3.7
37	9	10	7.4
17	4	44	32.5
36	6	3	2.2
11	3	44	32.5
75	1	40	29.5
28	12	30	22

Tolerance on Torque value: +0/-10%

ACCUMULATOR PRESSURE DP803

"OPERATING PRESSURE PSI [Bar]"	"ACCUMULATOR PRESSURE PSI [Bar]"
29-73 [2-5]	29 [2]
73-145 [5-10]	29-73 [2-5]
145-290 [10-20]	73-102 [5-7]

9915-KIT2004

KIT DIAPHRAGM DP803 DP1003

REF. No.	DESCRIPTION	QTY.
1	PRE-SET DURAMAX PISTON DIAPHRAGM	3
35	O-RING 3.53X28.17	6

9915-KIT2104

KIT SERVICE VALVE DP803 DP1003

REF. No.	DESCRIPTION	QTY.
2	VALVE ASSY	6
35	O-RING 3.53X28.17	6

9915-KIT2204

KIT REPAIR PUMP DP803 DP1003

REF. No.	DESCRIPTION	QTY.
16	O-RING 4.0x82	1
20	OIL SEAL DIA.35X52X7	1
35	O-RING DIA.3.53X28.17	6

LOW PRESSURE 15 BAR REPLACEMENT PARTS

TORQUE CHART DP1003			
REF. No.	Qty.	N-m	ft.Lbs
3	3	25	18.5
47	3	5 (LOXEAL 55-14)	3.7 (LOXEAL 55-14)
24	2	5	3.7
37	9	10	7.4
17	4	44	32.5
36	6	3	2.2
11	3	44	32.5
75	1	40	29.5
28	12	30	22
Tolerance on Torque value: +0/-10%			

ACCUMULATOR PRESSURE DP1003	
"OPERATING PRESSURE PSI [Bar]"	"ACCUMULATOR PRESSURE PSI [Bar]"
29-73 [2-5]	29 [2]
73-145 [5-10]	29-73 [2-5]
145-290 [10-20]	73-102 [5-7]

9915-KIT2004		
KIT DIAPHRAGM DP803 DP1003		
REF. No.	DESCRIPTION	QTY.
1	PRE-SET DURAMAX PISTON DIAPHRAGM	3
35	O-RING 3.53X28.17	6

9915-KIT2104		
KIT SERVICE VALVE DP803 DP1003		
REF. No.	DESCRIPTION	QTY.
2	VALVE ASSY	6
35	O-RING 3.53X28.17	6

9915-KIT2204		
KIT REPAIR PUMP DP803 DP1003		
REF. No.	DESCRIPTION	QTY.
16	O-RING 4.0x82	1
20	OIL SEAL DIA.35X52X7	1
35	O-RING DIA.3.53X28.17	6

LOW PRESSURE 15 BAR REPLACEMENT PARTS

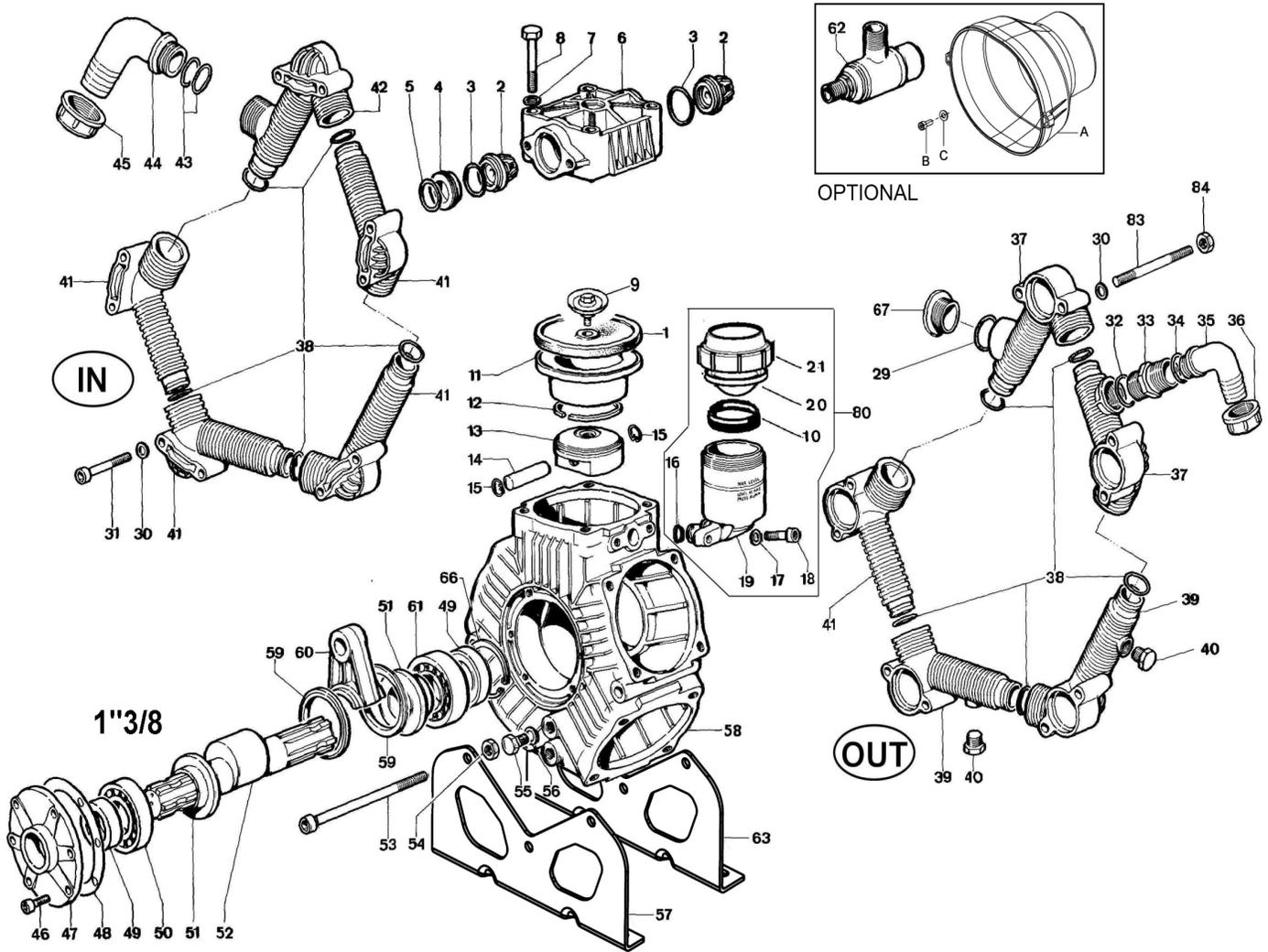

FIGURE 9: MODEL DP2505

LOW PRESSURE 15 BAR REPLACEMENT PARTS

TORQUE CHART DP2505

REF. No.	Qty.	N-m	ft.Lbs
9	5	25	18.4
40	2	20	14.8
18	2	5 (LOXEAL 24-18)"	3.7 (LOXEAL 24-18)"
55	1	8	5.9
46	6	40	29.5
64	2	22	16.3
31	20	22	16.3
53	3	10	7.4
8	20	40	29.5
91	4	40	29.5
83	20	10	7.4
84	20	10	7.4

Tolerance on Torque value: +0/-10%

ACCUMULATOR PRESSURE DP2505

"OPERATING PRESSURE PSI [Bar]"	"ACCUMULATOR PRESSURE PSI [Bar]"
29-73 [2-5]	29 [2]
73-145 [5-10]	29-73 [2-5]
145-290 [10-20]	73-102 [5-7]

9915-KIT2005

KIT DIAPHRAGM DP2505

REF. No.	DESCRIPTION	QTY.
1	PRE-SET DURAMAX PISTON DIAPHRAGM	5
3	O-RING 4.5x40 VITON	10

9915-KIT2105

KIT SERVICE VALVE DP2505

REF. No.	DESCRIPTION	QTY.
2	S.S. AISI 316 VALVE ASSY (STD.)	10
3	O-RING 4.5x40 VITON	10
5	O-RING 2.62x42.52 VITON	5

9915-KIT2205

KIT REPAIR PUMP DP2505

REF. No.	DESCRIPTION	QTY.
3	O-RING 4.5x40	10
5	O-RING 2.62x42.52 VITON	5
38	O-RING 3.53x31.34 VITON	10
48	COVER GASKET	1
49	OIL SEAL DIA.35x52x7	2

DIAPHRAGM PUMP: MEDIUM PRESSURE RANGE 20 - 40BAR

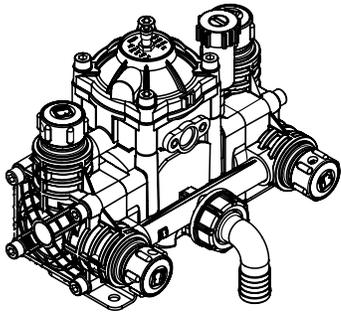

Model Number	"Max. Flow USGPM [LPM]"	"Max. Pressure PSI [BAR]"	"Max. Speed RPM"	"Power HP [KW]"	No. of Diaphragm
9915-DP252			650		
9915-DP252GRGI	6.3 [24]	290 [20]	3450	1.4 [1.1]	2
9915-DP252GRGI58			3450		

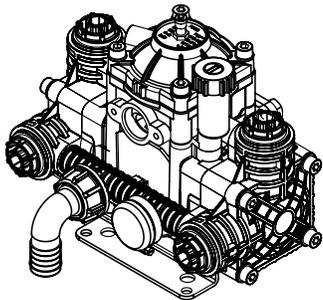

Model Number	"Max. Flow USGPM [LPM]"	"Max. Pressure PSI [BAR]"	"Max. Speed RPM"	"Power HP [KW]"	No. of Diaphragm
9915-DP302			650		
9915-DP302AP-A	7.1 [27]	290 [20]	3450	1.6 [1.2]	2
9915-DP302GRGI			3450		

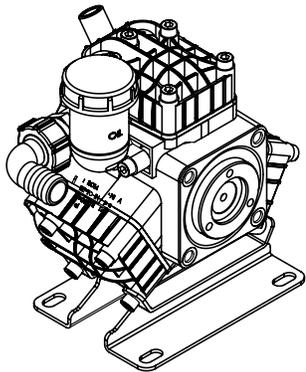

Model Number	"Max. Flow USGPM [LPM]"	"Max. Pressure PSI [BAR]"	"Max. Speed RPM"	"Power HP [KW]"	No. of Diaphragm
9915-D303			650		
9915-D303GRGI	8.1 [31]	580 [40]	3600	3.2 [2.4]	3
9915-D303AP-A			650		
9915-D403			550		
9915-D403GRGI	9.8 [37]	580 [40]	3000	3.9 [2.9]	3
9915-D503			550		
9915-D503GRGI	13.5 [51]	580 [40]	3300	5.4 [4.0]	3
9915-D503AP-A			550		

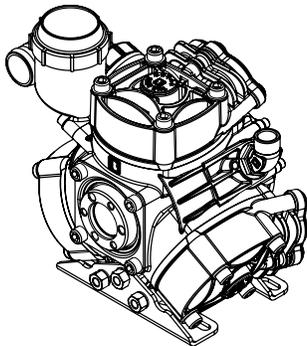

Model Number	"Max. Flow USGPM [LPM]"	"Max. Pressure PSI [BAR]"	"Max. Speed RPM"	"Power HP [KW]"	No. of Diaphragm
9915-DP503			550		
9915-DP503GRGI	13.5 [51]	580 [40]	3300	5.4 [4.0]	3
9915-DP503AP-A			550		

MEDIUM PRESSURE 20-40 BAR PERFORMANCE AND SPECIFICATIONS

DRIVE OPTIONS

Order the appropriate shaft adapter kit or gear reduction unit for the drive option requirements. Refer to the adjoining chart for proper selection.

Oil Capacity: Oil crankcase capacities are approximate. Fill oil to proper level in sight glass. Always make sure all the air is purged out of crankcase prior to operating.

Control Units: Control units are available for easy flow and pressure control of your sprayer system. These units include a manual dump valve and adjustable pressure relief valve to control pressure, a liquid-filled pressure gauge to monitor pressure, and shut-off valves to control flow. Control unit can be remote mounted with remote mounting kit. Refer to the adjoining chart to select the proper control unit for your pump and remote mounting kits.

Model Number	3/4" Solid Shaft	1" Solid Shaft W/Keyway	1-3/8" Male Splined Shaft	Gear Reduction Unit for Gas Drive Engine
9915-DP252	N/A	N/A	N/A	Order gear reduced models
9915-DP302	9915-KIT1201	9915-KIT1202	9915-KIT1203	Order gear reduced models
9915-D303	9915-KIT1201	9915-KIT1202	9915-KIT1203	9915-KIT1103
9915-D403	N/A	9915-KIT1202	9915-KIT1203	9915-KIT1103
9915-D503	N/A	9915-KIT1202	9915-KIT1203	9915-KIT1105
9915-DP503	N/A	9915-KIT1202	9915-KIT1203	9915-KIT1105

Control Unit Model Number	"Max. Flow USGPM [LPM]"	"Max. Pressure PSI [BAR]"	Pump Model	Remote Mounting Kits
9915-KIT1001	7.9 [30]	290 [20]	DP252	9915-KIT1403
9915-KIT1002	10.5 [40]	580 [40]	D303/D403	9915-KIT1404
9915-KIT1003	24 [90]	580 [40]	DP503/D503	9915-KIT1405
9915-KIT1008	10.5 [40]	290 [20]	DP302	9915-KIT1406

Crankcase Oil Capacity	
Pump Model Series	"Capacity oz. [Litre]"
DP252	24 [0.7]
DP302	24 [0.7]
D303	20 [0.6]
D403	20 [0.6]
D503	17 [0.5]
DP503	17 [0.5]

MEDIUM PRESSURE 20-40 BAR INSTALLATION

INSTALLATION INSTRUCTIONS FOR GEAR REDUCTION KIT 9915-KIT1103 (REFER TO FIGURE 10)

NOTE: Hypro recommends a blue thread locking compound on all threaded fasteners that do not require lock washers. Shaft key needs to be inspected occasionally and replaced if worn.

The 9915-KIT1103 gear reducer is designed for direct mounting diaphragm pumps (listed in chart on page 19) onto a 5 hp gasoline engine with a flange mounting and 3/4" solid shaft.

Assembly Instructions (Refer to Figure 10)

1. Take out from the pump the retaining ring sheet with the 4 corresponding fastening bolts.
2. Fasten the gear (Ref. 14) to the pump shaft by using the corresponding 3 bolts (Ref. 13) with torque 16.2lbf [22Nm].
3. Install the O-ring (Ref. 15) in the corresponding slot on the gear casing (Ref. 7), then fit the gear casing to the pump tightening the bolts M10x20 (Ref. 11) with torque 29.5lbf [40Nm].
4. Screw the oil drain plug (Ref. 9) with the proper washer (Ref. 8) and the oil sight (Ref. 12), then fill the gearbox casing with oil SAE 80-W90 up to the middle of the oil sight. Then install the oil filling plug (Ref. 10).
5. Insert the key (Ref. 2) the engine shaft and fit the centering ring (Ref. 1) on the gear casing.
6. Install the "pump-gearbox assy" on the engine and tighten the 4 corresponding bolts (Ref. 6) with torque 16.2lbf [22Nm].

INSTALLATION INSTRUCTIONS FOR GEAR REDUCTION KIT 9915-KIT1105 (REFER TO FIGURE 11)

Hypro recommends a blue thread locking compound on all threaded fasteners that do not require lock washers. Shaft key needs to be inspected occasionally and replaced if worn.

The 9915-KIT1105 gear reducer is designed for direct mounting the diaphragm pumps (listed in chart on page 19) onto an 8 hp gasoline engine with a flange mounting and 1" solid shaft.

Assembly Instructions (Refer to Figure 11)

1. Take out from the pump the retaining ring locking sheet with the 4 corresponding fastening bolts.
2. Install the O-ring (Ref. 9) in the half casing slot (pump side) (Ref. 19), then fit to the pump with the 4 corresponding with the 4 copper washer (Ref. 18) and bolts (Ref. 8) with torque 29.5lbf [40Nm].
3. Fit the ring gear (Ref. 17) to the pump shaft by using the corresponding screws (Ref. 15) and the proper safety washers (Ref. 16) with torque 29.5lbf [40Nm] along with thread sealant. In case the gearbox is fixed by M8 screws (ref. 20-21-22), tightening torque is 16.2 lbf [22Nm].
4. Screw the oil sight (Ref. 14) in the lateral part of the gearbox casing (Ref. 12).
5. Apply sealant on the top of the 2 half casings and install the engine side assembly on the pump side assembly. Fit the paper gasket (Ref. 13) between the 2 assemblies and fasten the whole system with corresponding bolts (Ref. 10) with torque 16.2lbf [22Nm].
6. Insert the key (Ref. 1) onto the engine shaft, fit the pump-gearbox assy to the engine and tighten the 4 corresponding bolts 3/8" (Ref. 6) and spring washers (Ref. 5) with torque 29.5lbf [40Nm].
7. Fill the gearbox casing with SAE 80-W90 oil, up to the middle of the oil sight, then install the oil vent plug (Ref. 11).

MEDIUM PRESSURE 20-40 BAR INSTALLATION

ENGINE SAE J609 3/4"

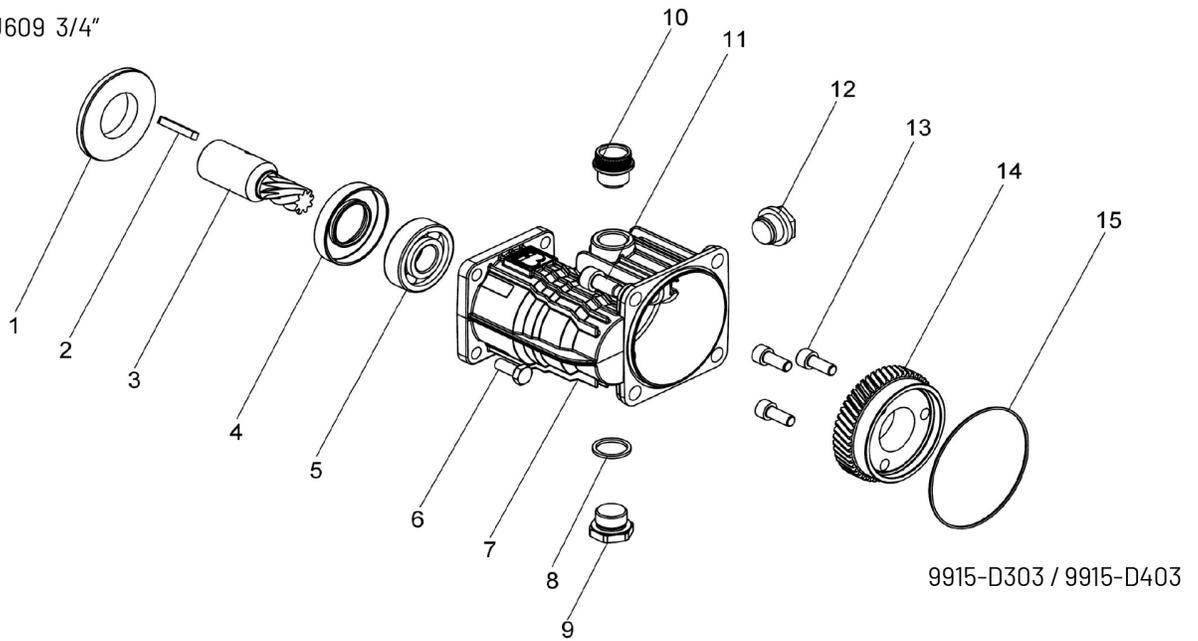

FIGURE 10: MODEL 9915-KIT1103

ENGINE SAE J609 1"

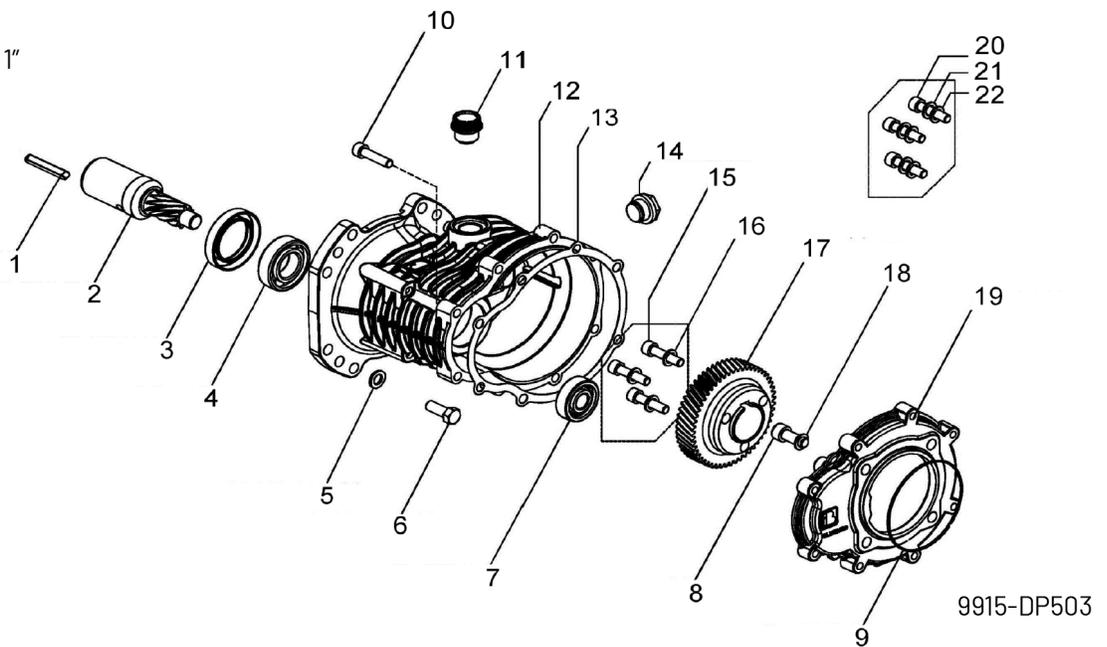

FIGURE 11: MODEL 9915-KIT1105

MEDIUM PRESSURE 20-40 BAR INSTALLATION

CONTROL UNIT KIT INSTALLATION

The control units are designed for control of pressure and flow rate. Use appropriate model (as specified in chart on page 19) to mount on particular pump model and pressure/flow ranges. Some models are mounted directly to pump and some can be mounted remotely with mounting Kits as specified in chart on page 19.

Hypro recommends a blue thread locking compound on all threaded fasteners that do not require lock washers.

Direct Mounting onto Pump

1. Locate the discharge flange port on the discharge manifold. Remove the nuts holding the flange manifold.
2. Remove the O-ring from the groove of the flange and install into the control unit flange.
3. Install the control unit onto the manifold where the discharge port had been previously. Use the nuts previously removed to secure the control unit.
4. Connect bypass hose to bypass hose barb and run unrestricted to supply tank.
5. Connect the desired number of high pressure hoses to the outlet hose barbs. Unused hose barbs can be shut off with ball valves provided.

Remote Mounting with Mounting Kit

1. Locate and secure the mounting bracket provided with mounting kit in the desired position.
2. Place O-rings into groove of relief valve body and discharge flange provided with mounting kit.
3. Assemble the control unit and discharge flange onto the bracket and secure with the bolts and nuts provided.
4. Use the high pressure hose to connect pump discharge port hose barb to the control unit inlet port hose barb
5. Connect the bypass hose to the bypass hose barb, then run it unrestricted to the supply tank.
6. Connect the desired number of high pressure hoses to the outlet hose barbs on the control valve. Unused hose barbs can be shut off with ball valves provided.

For all discharge hoses, use hose with an operating pressure rating equal to or greater than the maximum pressure rating of the pump. High pressure clamping should be used on all outlet hose connections.

▲ WARNING Always wear safety goggles when working with spring-loaded fasteners or devices.

▲ WARNING During the first step, you are strongly advised to start the pump with the regulating valve knob turned to 0 pressure and with the lever in the by-pass position. Maintain this configuration for a couple of minutes so as to lubricate the internal components of the pump and allow the diaphragms to set in position before the pressure is increased.

The restriction on the pump is removed by rotating the Pressure Release knob on the control unit, fully toward bypass arrow direction.

First back out the pressure regulator adjustment knob to zero. Then rotate the Pressure Release knob to Pressure arrow direction. Adjust the pressure by rotating the relief valve adjustment knob to the desired pressure.

MEDIUM PRESSURE 20-40 BAR INSTALLATION

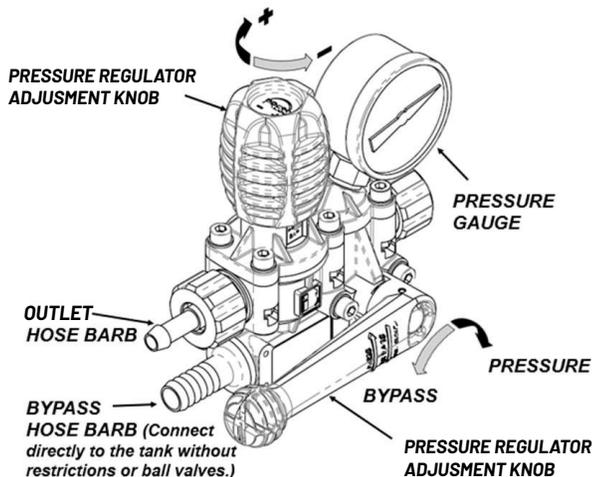

FIGURE 12: MODEL 9915-KIT1001

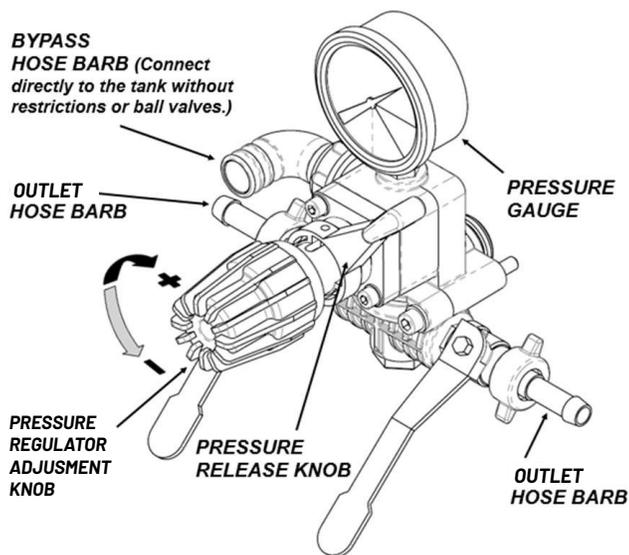

FIGURE 13: MODEL 9915-KIT1002 & 9915-KIT1008

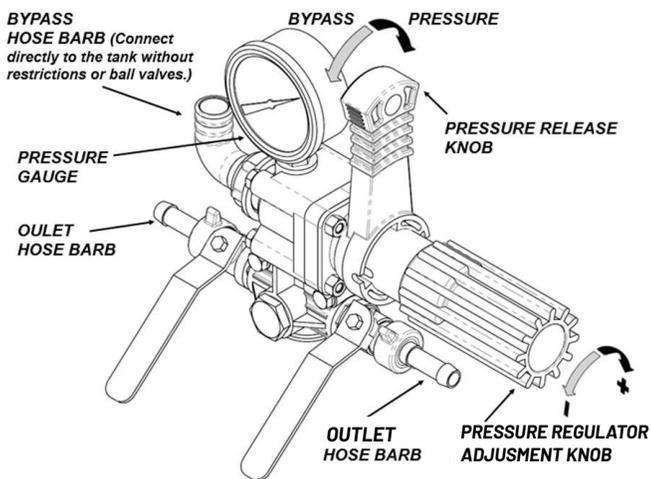
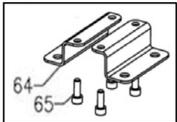

FIGURE 14: MODEL 9915-KIT1003

MEDIUM PRESSURE 20-40 BAR REPLACEMENT PARTS

INCLUDED WITH DP252



INCLUDED WITH DP302/DP302AP-A

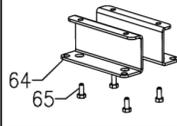

OPTIONAL

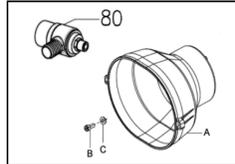

FOR GRGI MODELS (DP252/DP302)

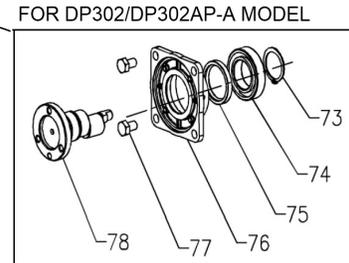
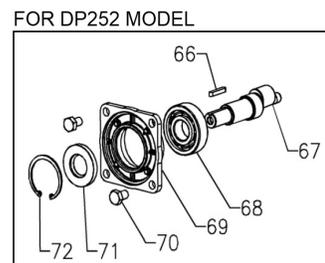
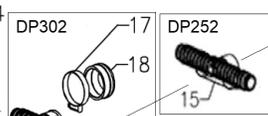
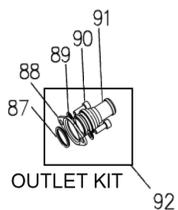
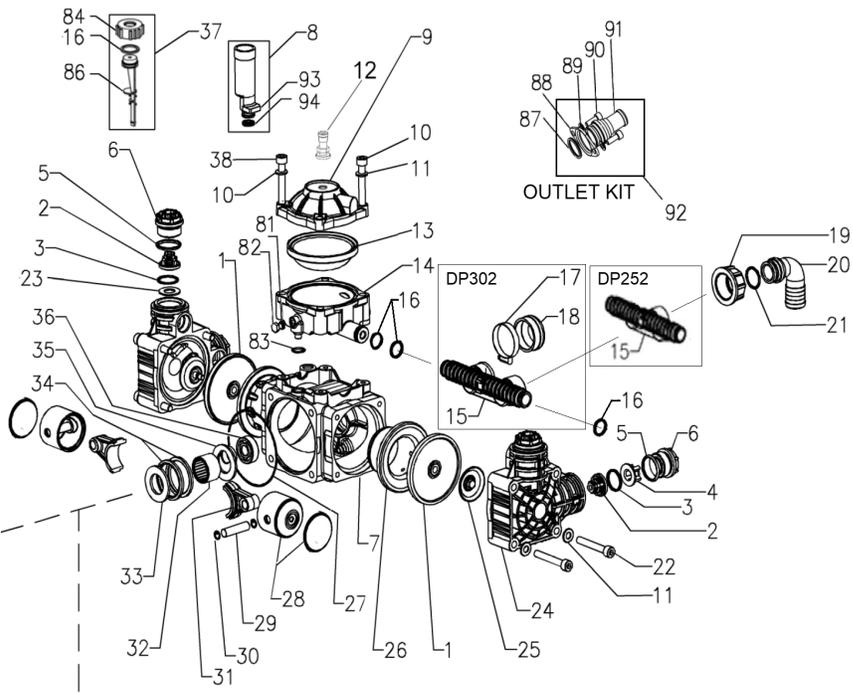
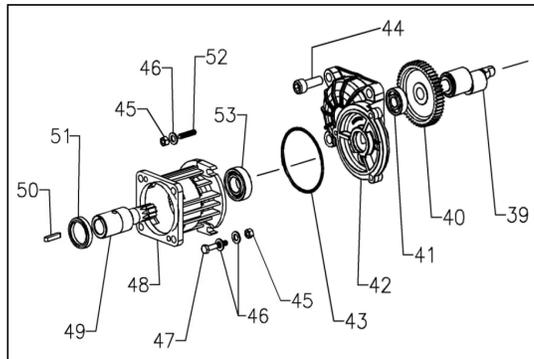

FIGURE 15: MODELS 9915-DP252, 9915-DP302

MEDIUM PRESSURE 20-40 BAR REPLACEMENT PARTS

TORQUE CHART DP252 DP302			
REF. No.	Qty.	N-m	ft.Lbs
22	8	10	7.4
25	2	5	3.7
12	1	5	3.7
38	2	10	7.4
10	2	10	7.4
44	4	40	29.5
47	2	10	7.4
52	1	10	7.4
55	2	10	7.4
58	2	10	7.4
45	3	10	7.4
6	4	10	7.4
65	4	10	7.4
70	4	40	29.5
77	4	40	29.5

Tolerance on Torque value: +0/-10%

ACCUMULATOR PRESSURE DP252 DP302	
"OPERATING PRESSURE PSI [Bar]"	"ACCUMULATOR PRESSURE PSI [Bar]"
29-73 [2-5]	29 [2]
73-145 [5-10]	29-73 [2-5]
145-290 [10-20]	73-102 [5-7]

9915-KIT2001		
KIT DIAPHRAGM DURAMAX DP252 DP302		
REF. No.	DESCRIPTION	QTY.
1	PRE-SET DURAMAX PISTON DIAPHRAGM (STD.)	2
13	DAMPENER DIAPHRAGM	1
16	O-RING D.2.62X15.54	4
3	O-RING D.2.62X22.22	4
5	O-RING D.2.62X26.65	4

9915-KIT2101		
KIT SERVICE VALVE DP252 DP302		
REF. No.	DESCRIPTION	QTY.
2	VALVE ASSY	4
3	O-RING D.2.62X22.22	4
4	SPACER INLET VALVE	2
5	O-RING D.2.62X26.65	4

9915-KIT2201		
KIT REPAIR PUMP DP252 DP302		
REF. No.	DESCRIPTION	QTY.
3	O-RING	4
16	O-RING	5
27	O-RING	1
43	O-RING	1
81	O-RING	1
83	O-RING	1
94	O-RING	1

MEDIUM PRESSURE 20-40 BAR REPLACEMENT PARTS

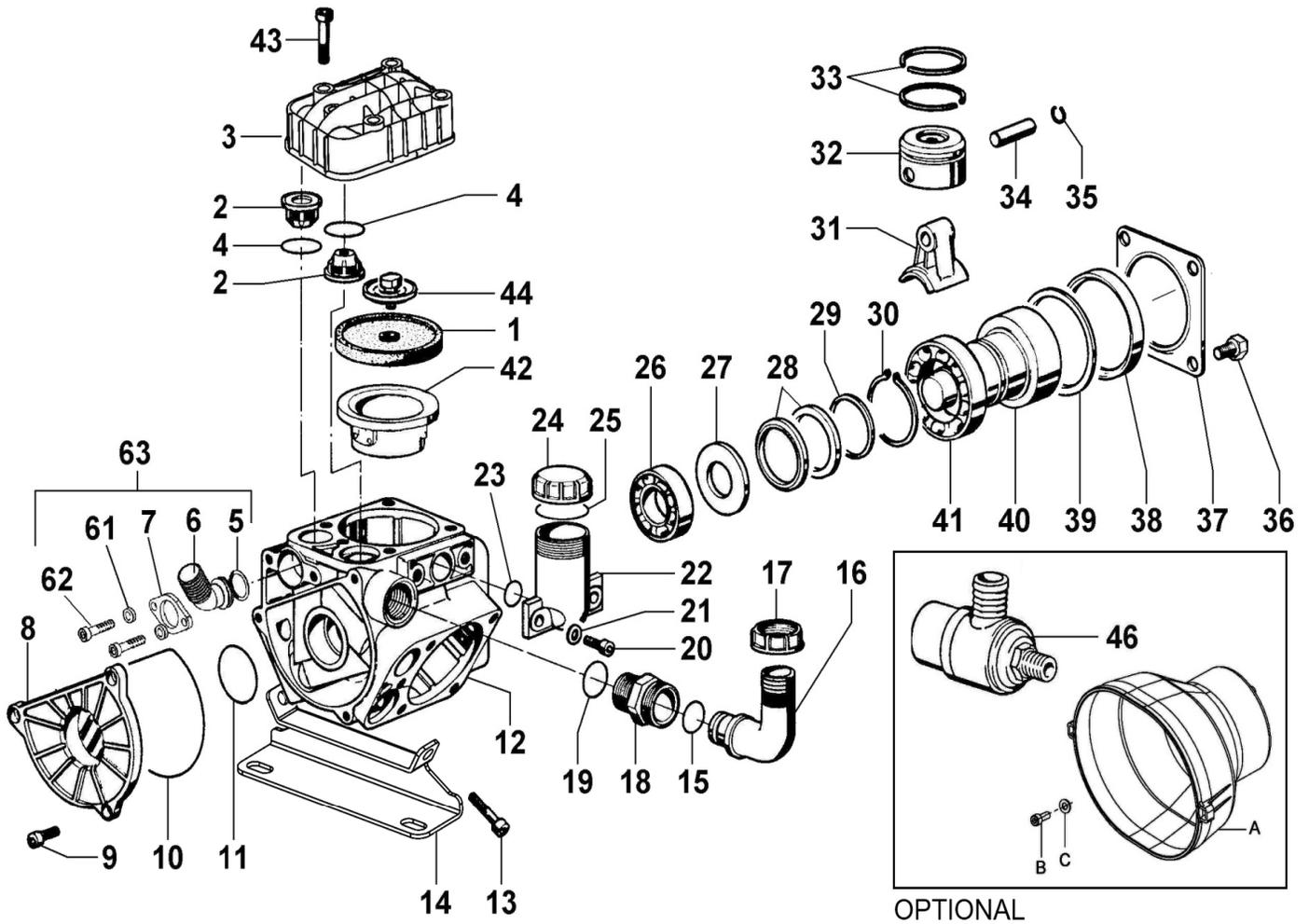

FIGURE 16: MODEL 9915-D303, 9915-D403

MEDIUM PRESSURE 20-40 BAR REPLACEMENT PARTS

TORQUE CHART D303, D403

REF. No.	Qty.	N-m	ft.Lbs
9	3	10	7.4
20	2	10	7.4
62	2	10	7.4
43	11	22	16.2
13	4	22	16.2
36	4	22	16.2
44	3	5	3.7

Tolerance on Torque value: +0/-10%

9915-KIT2002

KIT DIAPHRAGM D303, D403

REF. No.	DESCRIPTION	QTY.
1	DURAMAX PISTON DIAPHRAGM	3
4	VALVE SEAL	6

9915-KIT2102

KIT SERVICE VALVE D303, D403

REF. No.	DESCRIPTION	QTY.
2	VALVE ASSY	6
4	VALVE SEAL	6

9915-KIT2202

KIT REPAIR PUMP D303, D403

REF. No.	DESCRIPTION	QTY.
4	VALVE SEAL	6
10	O-RING 2.62X101.27	1
11	O-RING 2.62X36.14	1
38	OIL SEAL DIA. 68X90X10	1

MEDIUM PRESSURE 20-40 BAR REPLACEMENT PARTS

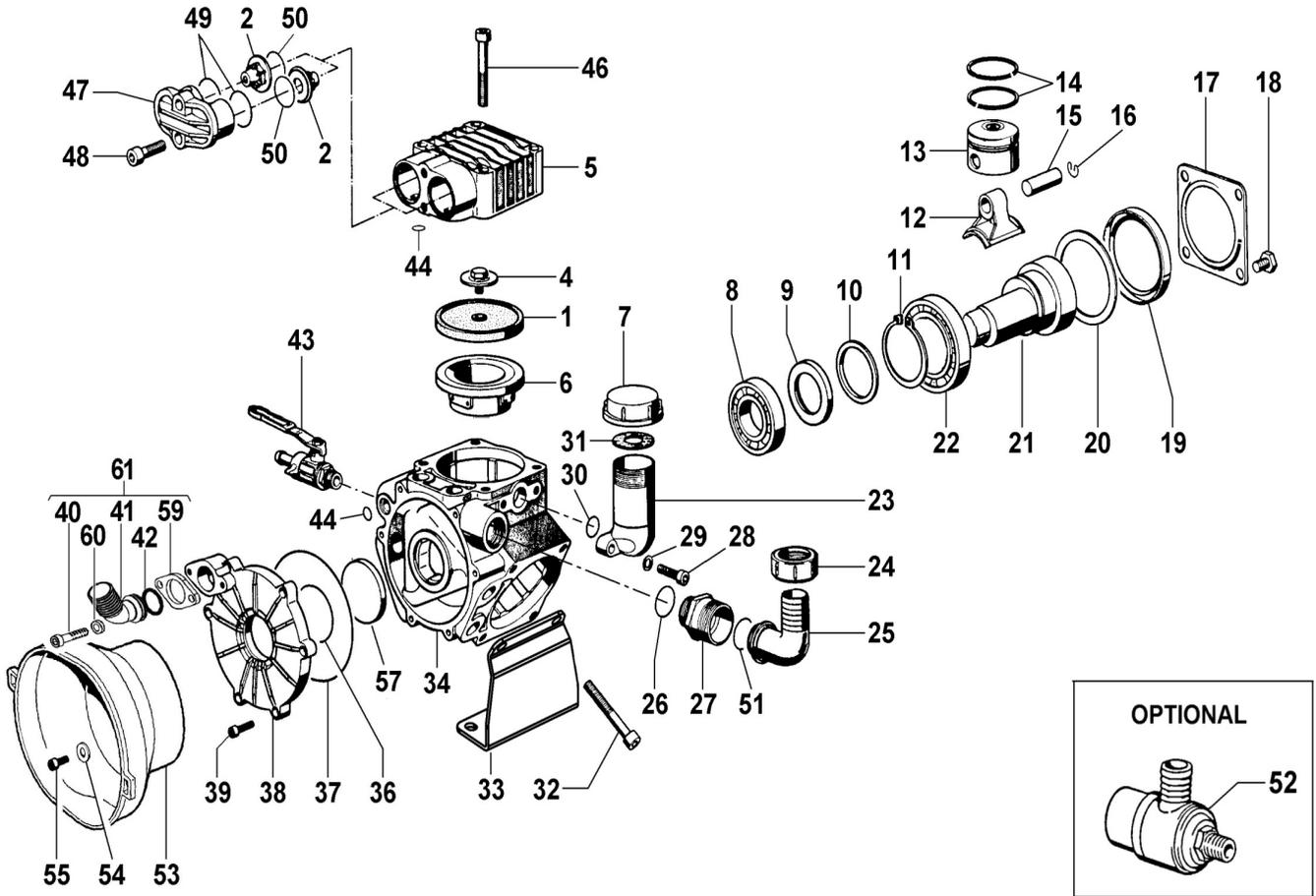

FIGURE 17: MODEL 9915-D503

MEDIUM PRESSURE 20-40 BAR REPLACEMENT PARTS

TORQUE CHART D503

REF. No.	Qty.	N-m	ft.Lbs
4	3	12	8.9
18	4	22	16.2
28	2	10	7.4
32	4	44	32.5
39	6	10	7.4
40	2	10	7.4
46	8	44	32.5
48	6	44	32.5

Tolerance on Torque value: +0/-10%

9915-KIT2008

KIT DIAPHRAGM D503

REF. No.	DESCRIPTION	QTY.
1	DURAMAX PISTON DIAPHRAGM	3
44	O-RING 2.62X18.72	6

9915-KIT2108

KIT SERVICE VALVE D503

REF. No.	DESCRIPTION	QTY.
2	VALVE ASSY	6
49	O-RING	6
50	O-RING	6

9915-KIT2208

KIT REPAIR PUMP D503

REF. No.	DESCRIPTION	QTY.
19	OIL SEAL	1
36	O-RING	1
37	O-RING	1
44	O-RING 2.62X18.72	6
49	O-RING	6
50	O-RING	6

MEDIUM PRESSURE 20-40 BAR REPLACEMENT PARTS

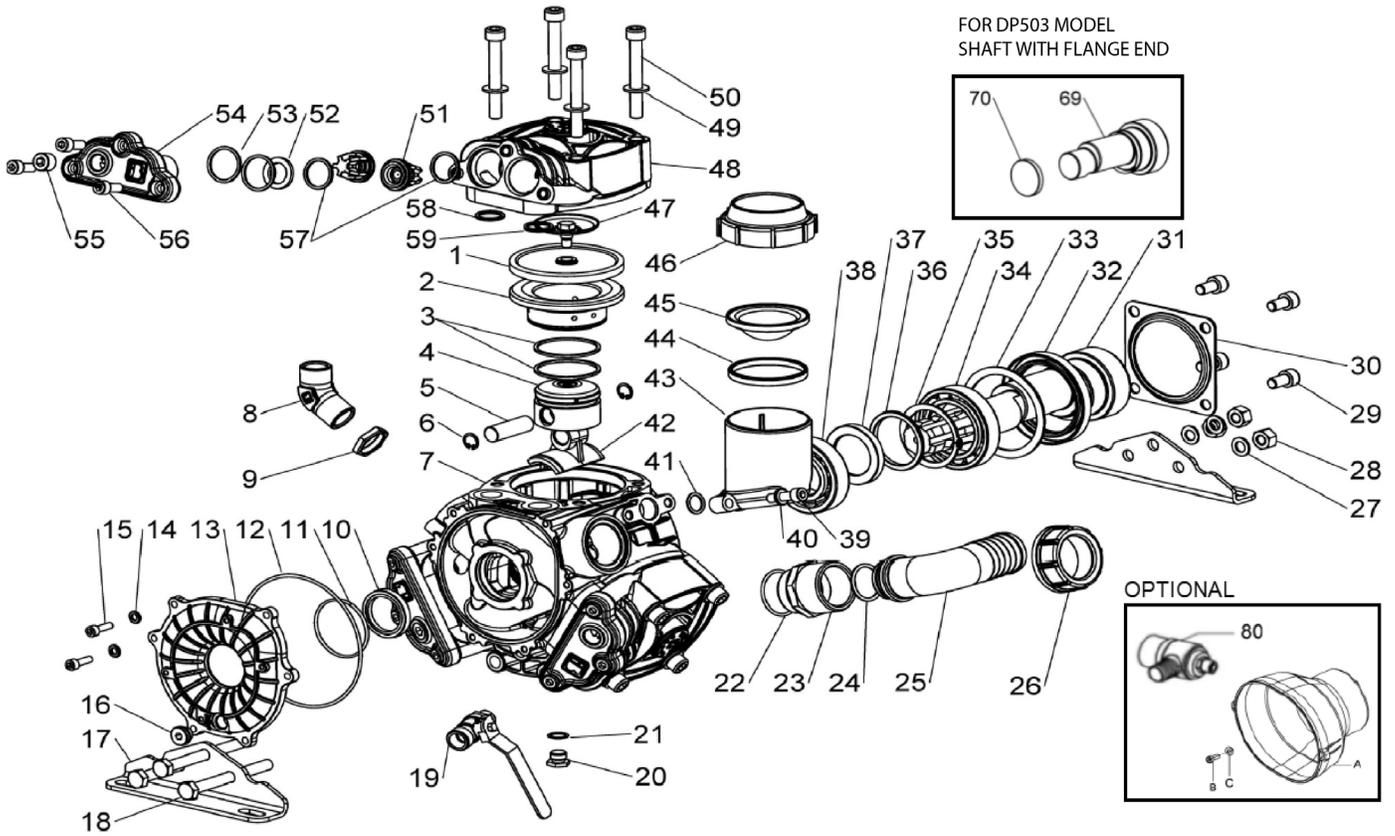

FIGURE 18: MODEL 9915-DP503

MEDIUM PRESSURE 20-40 BAR REPLACEMENT PARTS

TORQUE CHART DP503			
REF. No.	Qty.	N-m	ft.Lbs
15	6	10	7.4
16	1	5	3.7
18	3	44	32.4
20	1	22	16.2
28	3	44	32.4
29	4	22	16.2
39	2	10	7.4
47	3	12	8.8
50	12	30	22.1
55	2	"5 (APPLY THREAD SEALANT)"	"3.7 (APPLY THREAD SEALANT)"
56	9	22	16.2
73	4	44	32.4

Tolerance on Torque value: +0/-10%

9915-KIT2003		
KIT DIAPHRAGM DP503		
REF. No.	DESCRIPTION	QTY.
1	PRE-SET DURAMAX PISTON DIAPHRAGM	3
58	O-RING 2.62X18.72	3
59	O-RING 2.62X20.24	3

9915-KIT2103		
KIT SERVICE VALVE DP503		
REF. No.	DESCRIPTION	QTY.
51	VALVE ASSY	6
52	SPACER	3
53	O-RING 3.0X30	6
57	O-RING 2.62X25.07	6

9915-KIT2203		
KIT REPAIR PUMP DP503		
REF. No.	DESCRIPTION	QTY.
10	OIL SEAL	1
11	O-RING 2.62X53.65	1
12	O-RING 2.62X126.67	1
21	GASKET	1
32	OIL SEAL	1
53	O-RING 3.0X30	6
57	O-RING 2.62X25.07	6
58	O-RING 2.62X18.72	3
59	O-RING 2.62X20.24	3
70	COVER 47X7	1

DIAPHRAGM PUMP: HIGH PRESSURE RANGE 50 BAR

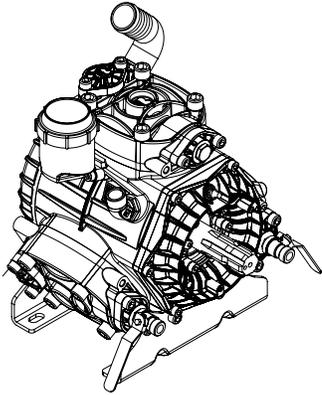

Model Number	"Max. Flow USGPM [LPM]"	"Max. Pressure PSI [BAR]"	"Max. Speed RPM"	"Power HP [KW]"	No. of Diaphragm
9915-D1063	27.9 [106]	725 [50]	550	13.9 [10.4]	3

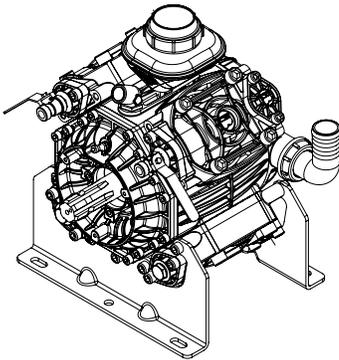

Model Number	"Max. Flow USGPM [LPM]"	"Max. Pressure PSI [BAR]"	"Max. Speed RPM"	"Power HP [KW]"	No. of Diaphragm
9915-D1504	38.8 [147]	725 [50]	550	19.3 [14.4]	4

CONTROL UNITS

Control units are available for easy flow and pressure control of your sprayer system. These units include a manual dump valve and adjustable pressure relief valve to control pressure, a liquid-filled pressure gauge to monitor pressure, and shut-off valves to control flow. Control unit 9915-KIT1006 and 9915-KIT1007 can be remote mounted. Refer to the adjoining chart to select the proper control unit for your pump.

Control Unit Model Number	"Max. Flow USGPM [LPM]"	"Max. Pressure PSI [BAR]"	Pump Model
9915-KIT1006	40 [150]	725 [50]	D1063/D1504
9915-KIT1007			

OIL CAPACITY

Oil crank case capacities are approximate. Fill oil to proper level in sight glass. Always make sure all the air is purged out of crankcase prior to operating.

Crankcase Oil Capacity	
Pump Model Series	Capacity oz. [Litre]
D1063	34 [1.0]
D1504	42 [1.25]

HIGH PRESSURE 50 BAR INSTALLATION

CONTROL UNIT KIT INSTALLATION

The control units are designed for control of pressure and flow rate. Use appropriate model (as specified in chart on page 32) to use with particular pump model and pressure/flow ranges.

NOTE: Hypro recommends a blue thread locking compound on all threaded fasteners that do not require lock washers.

REMOTE MOUNTING

1. Locate control unit at desired position with mounting holes provided and secure with the bolts and nuts.
2. Use the high pressure hose to connect pump discharge port hose barb to the control unit inlet port.
3. Connect the bypass hose to the bypass hose barb, then run it unrestricted to the supply tank.
4. Connect the desired number of high pressure hoses to the outlet ports on the control valve. Unused Ports can be shut off with ball valves provided.

For all discharge hoses, use hose with an operating pressure rating equal to or greater than the maximum pressure rating of the pump. High pressure clamping should be used on all outlet hose connections.

⚠ WARNING Always wear safety goggles when working with spring-loaded fasteners or devices.

⚠ WARNING During the first step, you are strongly advised to start the pump with the regulating valve knob turned to 0 pressure and with the lever in the by-pass position. Maintain this configuration for a couple of minutes so as to lubricate the internal components of the pump and allow the diaphragms to set in position before the pressure is increased.

The restriction on the pump is removed by rotating the Pressure Release knob on the control unit, fully toward bypass arrow direction. First back out the pressure regulator adjustment knob to zero. Then rotate the Pressure Release knob to Pressure arrow direction. Adjust the pressure by rotating the relief valve adjustment knob to the desired pressure.

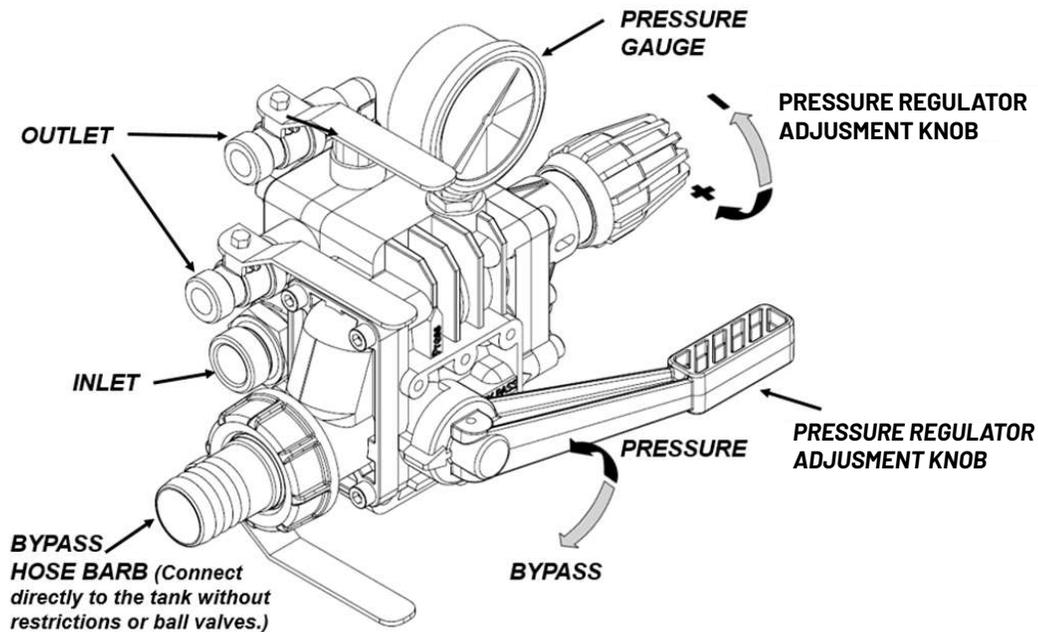

FIGURE 19: MODEL 9915-KIT1006

HIGH PRESSURE 50 BAR REPLACEMENT PARTS

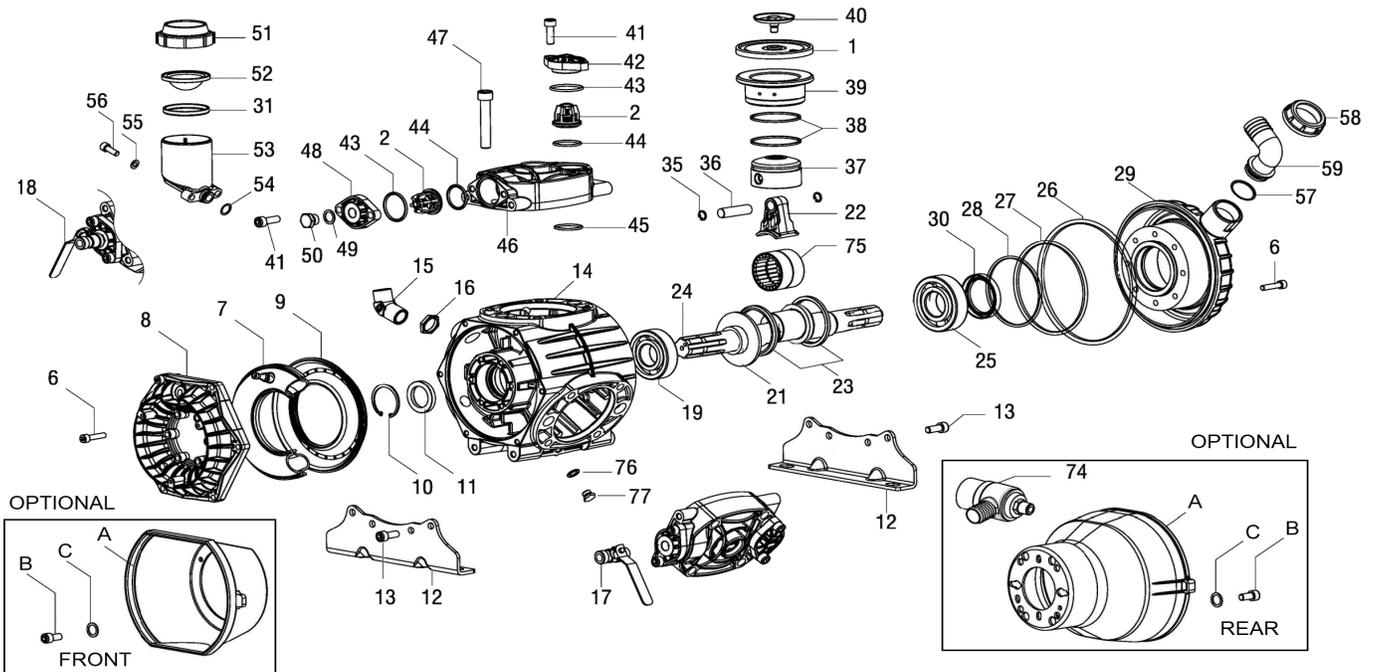

FIGURE 20: MODEL 9915-D1063

HIGH PRESSURE 50 BAR REPLACEMENT PARTS

TORQUE CHART D1063

REF. No.	Qty.	N-m	ft.Lbs
13	6	44	32.5
56	2	22	16.2
40	3	25	18.5
6	18	22	16.2
41	12	44	32.5
47	12	98	72.2

Tolerance on Torque value: +0/-10%

ACCUMULATOR PRESSURE D1063

"OPERATING PRESSURE PSI [Bar]"	"ACCUMULATOR PRESSURE PSI [Bar]"
29-73 [2-5]	29 [2]
73-145 [5-10]	29-73 [2-5]
145-290 [10-20]	73-102 [5-7]
290-580 [20-50]	87-116 [6-8]

9915-KIT2006

KIT DIAPHRAGM D1063

REF. No.	DESCRIPTION	QTY.
1	DESMOPAN PISTON DIAPHRAGM	3
7	NBR BALLASTER DIAPHRAGM	1
45	O-RING DIA.2,62x22,22	6

9915-KIT2106

KIT SERVICE VALVE D1063

REF. No.	DESCRIPTION	QTY.
2	VALVES ASSEMBLY	6
3	O-RING 3.53x41.28	6
5	O-RING 3.53x32.93	6

9915-KIT2206

KIT REPAIR PUMP D1063

REF. No.	DESCRIPTION	QTY.
11	OIL SEAL 40x52x7	1
26	O-RING 3.53x190.1	1
27	O-RING 2.62x126.67	1
28	O-RING 3.53x88.5	1
30	OIL SEAL 40x72x10	1
43	O-RING 3.53x41.28	6
44	O-RING 3.53x32.93	6
45	O-RING 2.62x22.22	6

HIGH PRESSURE 50 BAR REPLACEMENT PARTS

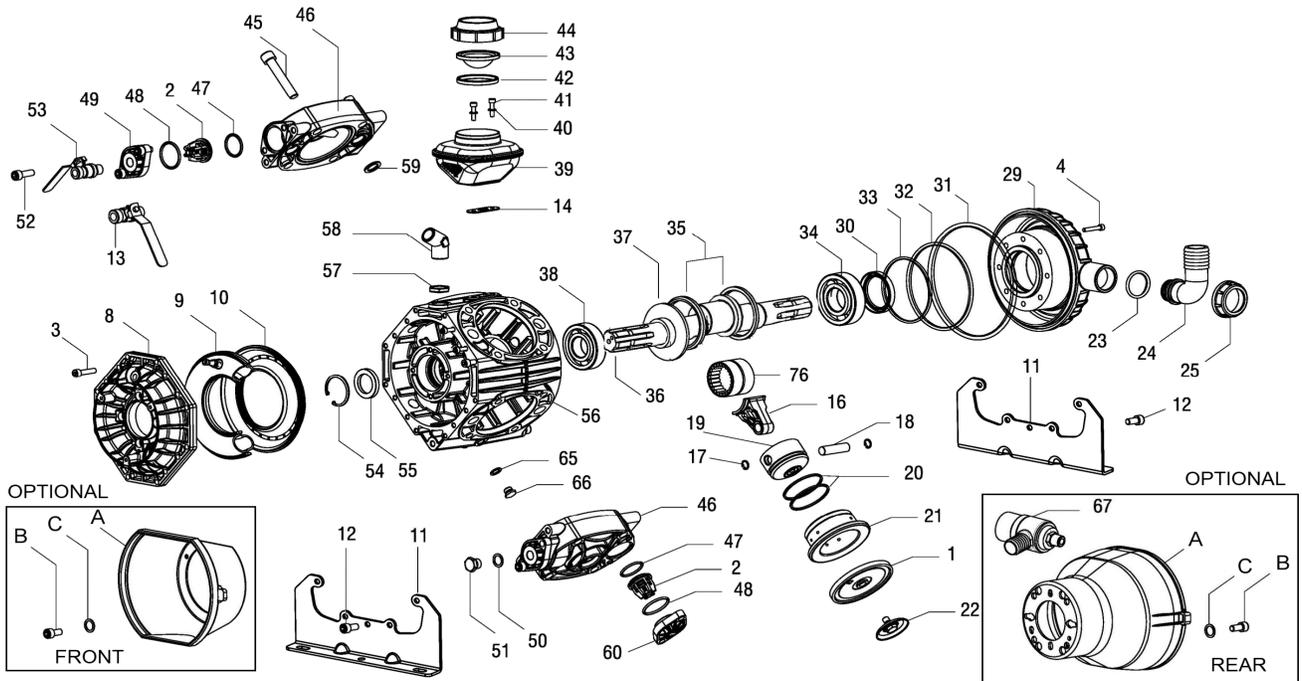

FIGURE 21: MODEL 9915-D1504

HIGH PRESSURE 50 BAR REPLACEMENT PARTS

TORQUE CHART D1504

REF. No.	Qty.	N-m	ft.Lbs
3	20	22	16.2
4	8	22	16.2
12	10	44	32.5
22	4	25	18.5
45	16	108	79.7
52	16	44	32.5
66	1	22	16.2

Tolerance on Torque value: +0/-10%

ACCUMULATOR PRESSURE D1504

"OPERATING PRESSURE PSI [Bar]"	"ACCUMULATOR PRESSURE PSI [Bar]"
29-73 [2-5]	29 [2]
73-145 [5-10]	29-73 [2-5]
145-290 [10-20]	73-102 [5-7]
290-580 [20-50]	87-116 [6-8]

9915-KIT2007

KIT DIAPHRAGM D1504

REF. No.	DESCRIPTION	QTY.
1	DESMOPAN PISTON DIAPHRAGM	4
9	NBR BALLASTER DIAPHRAGM	1
59	O-RING DIA.2.62x22.22	8

9915-KIT2107

KIT SERVICE VALVE D1504

REF. No.	DESCRIPTION	QTY.
2	VALVES ASSEMBLY	8
47	O-RING DIA.3,53x32,93	8
48	O-RING DIA.3,53x41,28	8

9915-KIT2207

KIT REPAIR PUMP D1504

REF. No.	DESCRIPTION	QTY.
30	OIL SEAL DIA.40x72x10 "VD"	1
31	O-RING DIA.3.53x190.10	1
32	O-RING DIA.2.62x126.67	1
33	O-RING DIA.3.53x88.5	1
47	O-RING DIA.3.53x32.93	8
48	O-RING DIA.3.53x41.28	8
55	OIL SEAL DIA.40x52x7	1
59	O-RING DIA.2.62x22.22	8

TROUBLESHOOTING

SYMPTOM	POSSIBLE CAUSE	CORRECTIVE ACTION
The pump does not draw water	One or more valves are seating improperly.	Remove valve and check for debris. Remove any debris found. Examine the valve seating and clean them.
	Suction line is plugged or collapsed. Clogged strainer	Examine and clean the suction line. Clean the strainer.
The liquid flow is irregular. The pump is noisy. The pressure gauge fluctuates.	The charge in the pulsation dampener is incorrect.	Check the pressure in the pulsation dampener. (It should be 20% of your spray pressure)
	One or more valves are seating improperly.	Remove valve and check for debris. Remove any debris found. Examine the valve seating and clean them.
	Pump is sucking air, or air hasn't been evacuated completely.	Start the pump with the gun open to evacuate the air.
Output drops and the pump is noisy	The oil level is too low.	Add oil to the correct level (halfway up the sight tube).
Oil comes out of the discharge port or oil is a milky color.	One or more diaphragms have split.	Remove the manifold and heads. Drain the oil and clean the crankcase of water. Replace the diaphragms, heads, and manifold. Refill with Hypro Oil (part number 2160-0038).
Oil comes out from the oil seal of the shaft.	Damaged or worn oil seal.	Replace the oil seal.
	Too much oil into the crankcase	Check the oil level and reset the correct one.
The pump fails to prime	Air sucked	Check the suction circuit
	Pressure adjusting valve in the "Press" position	Set the regulating valve in the "bypass" position.
The pump doesn't reach the required pressure	Valves have worn seals.	Check valves.
	Suction hose with air pockets or irregular elbows.	Check hose.
	Clogged stainer	Clean strainer
	R.P.M. too slow.	Make sure that the pump RPM correspond to the value indicated on the label

TROUBLESHOOTING

Examples of diaphragms failures & causes

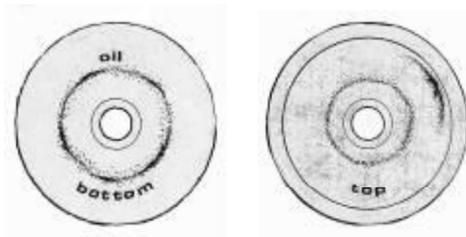

CIRCULAR FRACTURE ON PISTON SIDE OF DIAPHRAGM WHICH IS SAME DIAMETER AS PISTON
POSSIBLE CAUSES:

1. BLOW-BY BETWEEN PISTON AND SLEEVE
2. SUCTION HAS TOO MUCH PRESSURE (EXCESSIVE HEAD)
3. LOW PUMP RPM
4. DELIVERY VALVE NOT SEALING
5. LOW OIL LEVEL IN PUMP



CHEMICAL INCOMPATIBLE WITH DIAPHRAGM MATERIAL
POSSIBLE CAUSES:

1. FATIGUED AND WORN UNDERNEATH PISTON RETAINING DISC
2. DIAPHRAGM SWOLLEN AND SOFT
3. DIAPHRAGM SOFT AND SPONGY
4. INCREASE IN EXTERNAL DIAMETER



FRACTURE ON EXTERNAL DIAMETER, AND FATIGUE AND WORN UNDERNEATH PISTON RETAINING DISC
POSSIBLE CAUSES:

1. FATIGUE BREAKAGE DIAPHRAGM WORN OUT



A STRAIGHT FRACTURE
POSSIBLE CAUSES:

1. INCORRECT AIR BLEEDING, AIR TRAPPED UNDER DIAPHRAGM
2. BLOCKED SUCTION

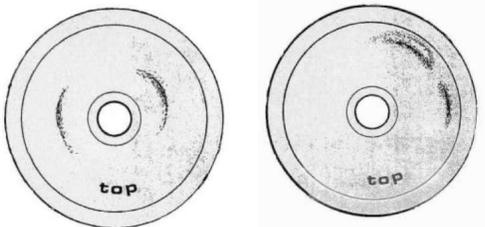

TWO SMALL FRACTURES CORRESPONDING TO VALVE POSITION
POSSIBLE CAUSES:

1. RESTRICTED SUCTION
2. PUMP RPM ABOVE SPECIFICATION
3. SUCTION VALVE NOT SEALING
4. CHEMICAL INCOMPATIBLE WITH DIAPHRAGM MATERIAL

▲WARNING Too much oil creates pressure inside the crankcase, giving rise to possible leaks or rupturing the diaphragms owing to overpressure. For pump models without the oil drain plug, periodic oil changing must be carried out when the pump components are checked for wear, we recommend at the end of each season or after every 500 hours service. The oil is drained out by disassembling a head and relative piston sleeve.

WARRANTY

Hypro/SHURflo (hereafter, "Hypro") agricultural products are warranted to be free of defects in material and workmanship under normal use for the time periods listed below, with proof of purchase.

- Pumps: one (1) year from the date of manufacture, or one (1) year of use. This limited warranty will not exceed two (2) years, in any event.
- Accessories: ninety (90) days of use.

This limited warranty will not apply to products that were improperly installed, misapplied, damaged, altered, or incompatible with fluids or components not manufactured by Hypro. All warranty considerations are governed by Hypro's written return policy.

Hypro's obligation under this limited warranty policy is limited to the repair or replacement of the product. All returns will be tested per Hypro's factory criteria. Products found not defective (under the terms of this limited warranty) are subject to charges paid by the returnee for the testing and packaging of "tested good" non-warranty returns.

No credit or labor allowances will be given for products returned as defective. Warranty replacement will be shipped on a freight allowed basis. Hypro reserves the right to choose the method of transportation.

This limited warranty is in lieu of all other warranties, expressed or implied, and no other person is authorized to give any other warranty or assume obligation or liability on Hypro's behalf. Hypro shall not be liable for any labor, damage or other expense, nor shall Hypro be liable for any indirect, incidental or consequential damages of any kind incurred by the reason of the use or sale of any defective product.

Return Procedures

All products must be flushed of any chemical (ref. OSHA section 1910.1200 (d) (e) (f) (g) (h)) and hazardous chemicals must be labeled/tagged before being shipped* to Hypro for service or warranty consideration. Hypro reserves the right to request a Material Safety Data Sheet from the returnee for any pump/product it deems necessary. Hypro reserves the right to "disposition as scrap" products returned which contain unknown fluids. Hypro reserves the right to charge the returnee for any and all costs incurred for chemical testing, and proper disposal of components containing unknown fluids. Hypro requests this in order to protect the environment and personnel from the hazards of handling unknown fluids.

Be prepared to give Hypro full details of the problem, including the model number, date of purchase, and from whom you purchased your product. Hypro may request additional information, and may require a sketch to illustrate the problem.

Contact the appropriate Hypro Service Department to receive a Return Merchandise Authorization number (RMA#). Returns are to be shipped with the RMA number clearly marked on the outside of the package. Hypro shall not be liable for freight damage incurred during shipping. Please package all returns carefully. All products returned for warranty work should be sent shipping charges prepaid:

US/Canada
HYPRO / PENTAIR
Attention: Service Department
375 Fifth Avenue NW
New Brighton, MN 55112
Service: 800-468-3428
Fax: 651-766-6618
Technical: 800-445-8360
hypro.technical@pentair.com

Europe
HYPRO EU Ltd.
Station Road
Longstanton
Cambridge CB24 3DS UK
Service/Technical:
+44 1954 260097
Fax: +44 1954 260245
euagorders@pentair.com

South America & Central America
Pentair Water do Brasil LTDA
Av. Marginal Norte da Via
Anhanguera, 53.700
Jundiaí/SP - Brasil
CEP 13206-245
Tel: (11) 3378-5400
vendas.pwdb@pentair.com

All Other Regions
HYPRO / PENTAIR
Attention: Service Department
375 Fifth Avenue NW
New Brighton, MN 55112
Service: 800-468-3428
Fax: 651-766-6618
Technical: 800-445-8360
hypro.technical@pentair.com

*Carriers, including U.S.P.S., airlines, UPS, ground freight, etc., require specific identification of any hazardous material being shipped. Failure to do so may result in a substantial fine and/or prison term. Check with your shipping company for specific instructions.



375 Fifth Avenue
NW New Brighton, MN 55112 US
Phone: (651) 766-6300, 800-424-9776
Fax: 800-323-6496

pentair.com