

**Model: 10-6408-0000**  
**Electric Lavatory Service Unit**



06/2011 – Rev. 03

REVISION	DATE	TEXT AFFECTED
01	02/2010	Original release
02	04/2010	Modified 2.1 Modified Lav Service Unit Parts List
03	06/2011	Modified Parts List Illustration

**TABLE OF CONTENTS**

	<b><u>PAGE</u></b>
<b>1.0 GENERAL DESCRIPTION .....</b>	<b>1</b>
<b>2.0 TECHNICAL SPECIFICATIONS.....</b>	<b>1</b>
2.1 FILL (FRESH) SYSTEM.....	1
2.2 DUMP SYSTEM.....	1
2.3 MECHANICAL.....	1
2.4 FACTORY INSTALLED OPTIONS & FIELD INSTALLED KITS .....	1
<b>3.0 PREPARATION FOR USE .....</b>	<b>1</b>
<b>4.0 SAFETY .....</b>	<b>2</b>
<b>5.0 OPERATING INSTRUCTIONS .....</b>	<b>2</b>
<b>6.0 MAINTENANCE.....</b>	<b>2</b>
6.1 BATTERY .....	2
<b>7.0 STORAGE.....</b>	<b>3</b>
<b>8.0 TROUBLE SHOOTING .....</b>	<b>3</b>
<b>9.0 PROVISION OF SPARES.....</b>	<b>3</b>
9.1 SOURCE OF SPARE PARTS.....	3
9.2 RECOMMENDED SPARE PARTS LISTS .....	3
<b>10.0 GUARANTEES/LIMITATION OF LIABILITY .....</b>	<b>3</b>
<b>11.0 APPENDICES .....</b>	<b>3</b>

This product can not be modified without the written approval of Tronair, Inc. Any modifications done without written approval voids all warranties and releases Tronair, Inc., its suppliers, distributors, employees, or financial institutions from any liability from consequences that may occur. Only Tronair OEM replacement parts shall be used.

## **1.0 GENERAL DESCRIPTION**

The Tronair Model 10-6408-0000 Lavatory Service Unit provides a clean, sanitary means of servicing the aircraft lavatory system and transporting the waste fluid to the dump station.

Some important features are:

- Easily maneuverable with Towbar
- Drain back system on fill hose to prevent fluid spillage
- Storage tubes for storage of fill and dump hoses
- Heavy duty fill and dump pumps
- Fill and dump tanks made of non-corroding HD polyethylene material with UV inhibitor
- Permanent connection of dump hose to dump tank

## **2.0 TECHNICAL SPECIFICATIONS**

- Dimensions: 54 inches long x 36 inches Wide x 22 inches High
- Weight: 280 pounds

### **2.1 FILL (FRESH) SYSTEM**

- 15 gallon tank capacity; HD polyethylene
- Electric fill pump (4.5 gpm)
- Three inch tank fill port with cover
- Eight foot fill hose

### **2.2 DUMP SYSTEM**

- 31 gallon tank capacity; HD polyethylene
- 30 GPM manual diaphragm pump
- Six (6) inch tank clean out port with cover
- Four (4) inch aluminum tank flange for aircraft dump hose connection
- 10 foot dump tank hose

### **2.3 MECHANICAL**

- Eight (8) inch pneumatic tires; 50 psi tire pressure maximum
- Roller bearings in wheels; zerk fittings
- Speed:10 mph maximum

### **2.4 FACTORY INSTALLED OPTIONS & FIELD INSTALLED KITS**

- Option 02: Three (3) inch dump tank flange for Shorts SD 330/360 aircraft.
- Option 03: Three (3) and four (4) inch dump tank flanges for Shorts SD 330/360 aircraft, and other aircraft using standard Wye connection.
- K-1036: Dump hose SD 330/360
- K-2029: Kit, Dump Connector
- K-2030: Kit, Dump Connector; mates with K-2412
- K-2410: Kit, Fill Connector
- K-2412: Kit, Dump Connector with five (5) foot hose
- K-3606 Kit, Hose Cap (Dump Hose)

## **3.0 PREPARATION FOR USE**

This Lavatory Service Unit has been thoroughly inspected and tested prior to packaging and shipment. The unit is shipped completely assembled and is ready for use.

You are requested to generally check over the unit to assure the tightness of all nuts, bolts and screws that may have loosened during shipment. Bolts and elastic stopnuts should be tightened to a torque not to exceed industry standards for Grade "5" bolts. Tire pressure should not exceed 50 psi.

#### 4.0 SAFETY

The operation, maintenance, and trouble shooting of the Electric Lavatory Service Unit requires practices and procedures which ensure personal safety and the safety of others. Therefore, this equipment is to be operated and maintained only by qualified persons in accordance with this manual and all applicable codes.

Safety instructions specifically pertaining to this kit appear throughout this manual, highlighted by the signal words **WARNING!** and **CAUTION!** which identify different levels of hazard.



**WARNING!** Denotes practices which if not carefully followed, could result in *serious injury and/or death*.

**CAUTION!** Denotes practices which if not carefully followed, could result in *minor personal injury or damage to this equipment*.

**General:** Information presented in this manual and on various labels on this unit pertain to equipment specifications, Installation, Operation, Maintenance and Trouble Shooting which should be read, understood, and followed for the safe use of this equipment.

**Training:** Read this entire manual prior to operation of the unit. All personnel using this Electric Lavatory Service Unit should understand and follow this manual and receive training. We encourage our customers to call Tronair to discuss any operating or testing requirements, telephone: (419) 866-6301 or (800) 426-6301.

#### 5.0 OPERATING INSTRUCTIONS

1. Open access panel on aircraft. Remove drain and fill coupling caps.
2. Connect dump hose assembly to aircraft drain coupling and fill hose assembly to mating aircraft coupling.
3. Follow aircraft manufacturer's instructions to drain sewage from aircraft into dump tank.
4. To flush aircraft toilet, the three way ball valve on the fill pump must have its handle pointing vertical. Follow aircraft manufacturer's requirements for flushing.
5. After flushing, rotate three-way ball valve handle to point horizontal. This allows for fill hose to be partially drained prior to disconnecting from aircraft.
6. Remove dump and fill hoses from aircraft and stow.
7. Following aircraft manufacturer's instructions, replace coupling caps on aircraft fittings. Close access panel.
8. Pump sewage into approved disposal system. Refill fill tank as required. Lavatory Service Unit is now ready for re-use.

#### 6.0 MAINTENANCE

1. Lubricate wheel bearings with multi-purpose grease; every 6 months minimum.
2. Lubricate front caster swivel plate bearings with multi-purpose grease; every 6 months minimum.
3. Periodically check for leaks at hose connections and tighten hose clamps, as required.
4. Regularly wash tanks and hoses with a mild detergent according to local procedures and regulations.

##### 6.1 BATTERY

#### **WARNING!**



**Battery posts, terminals and related accessories contain lead and lead compounds; chemicals known to the State of California to cause cancer and reproductive harm.**

**Wash hand after handling.**



**EXPLOSIVE GAS!** Batteries produce explosive hydrogen gas while being charged. To prevent a fire or explosion, charge batteries only in well ventilated areas. Keep sparks, open flames, and other sources of ignition away from the battery at all times. Keep batteries out of the reach of children. Remove all jewelry when servicing batteries.

**Before disconnecting the negative (-) ground cable, make sure all switches are OFF. If ON, a spark will occur at the ground cable terminal, which could cause an explosion if hydrogen gas or gasoline vapors are present.**



**ELECTRICAL SHOCK!** Never touch electrical wires or components. They can be sources of electrical shock.

1. Remove battery box cover.
2. Inspect battery connections for tightness and cleanliness.
3. Inspect condition of battery by sight glass located on top, should be green in color. If not, ensure battery is charged. If still not green, replace battery.
4. Re-install battery box cover and secure with strap.

## 7.0 STORAGE

1. The tank must be drained before storage.
2. Disconnect all battery connections.
3. Store the unit in a clean, dry place when not in use.
4. Be sure that all hoses are capped and the unit is covered with a lint free covering.
5. After storage, clean the tank as outlined in the maintenance section of this manual.

## 8.0 TROUBLE SHOOTING

1. If fill pump fails during use, refer to Appendix I. Failure to pump liquid may be caused by the following reasons:  
**Pump Will Not Prime:** Clogged Suction; check that suction tubes are clear.  
**Not Enough Flow:** Check suction and discharge hoses for clogging or pinching. Verify that nozzle is not clogged.
2. If dump pump fails during use, refer to Illustrated Parts List for WC-1054 Discharge Pump Assembly and disassemble for inspection of pump internals. Clean inside of pump. Replace any damaged parts.

## 9.0 PROVISION OF SPARES

### 9.1 SOURCE OF SPARE PARTS

Spare parts may be obtained from the manufacturer:

**TRONAIR, Inc.**

1 Air Cargo Pkwy East  
Swanton, Ohio 43558 USA

Telephone: (419) 866-6301 or 800-426-6301

Fax: (419) 867-0634

E-mail: sales@tronair.com

Website: www.tronair.com

### 9.2 RECOMMENDED SPARE PARTS LISTS

Reference the following page(s) for Replacement Parts and Kits available.

## 10.0 GUARANTEES/LIMITATION OF LIABILITY

Tronair products are warranted to be free of manufacturing or material defects for a period of one year after shipment to the original customer. This is solely limited to the repair or replacement of defective components. This warranty does not cover the following items:

- a) Parts required for normal maintenance
- b) Parts covered by a component manufacturers warranty
- c) Replacement parts have a 90-day warranty from date of shipment

If you have a problem that may require service, contact Tronair immediately. Do not attempt to repair or disassemble a product without first contacting Tronair, any action may affect warranty coverage. When you contact Tronair be prepared to provide the following information:

- a) Product Model Number
- b) Product Serial Number
- c) Description of the problem

If warranty coverage is approved, either replacement parts will be sent or the product will have to be returned to Tronair for repairs. If the product is to be returned, a Return Material Authorization (RMA) number will be issued for reference purposes on any shipping documents. Failure to obtain a RMA in advance of returning an item will result in a service fee. A decision on the extent of warranty coverage on returned products is reserved pending inspection at Tronair. Any shipments to Tronair must be shipped freight prepaid. Freight costs on shipments to customers will be paid by Tronair on any warranty claims only. Any unauthorized modification of the Tronair products or use of the Tronair products in violation of cautions and warnings in any manual (including updates) or safety bulletins published or delivered by Tronair will immediately void any warranty, express or implied.

The obligations of Tronair expressly stated herein are in lieu of all other warranties or conditions expressed or implied. **Any unauthorized modification of the Tronair products or use of the Tronair products in violations of cautions and warnings in any manual (including updates) or safety bulletins published or delivered by Tronair will immediately void any warranty, express or implied and Tronair disclaims any and all liability for injury (WITHOUT LIMITATION and including DEATH), loss or damage arising from or relating to such misuse.**

## 11.0 APPENDICES

APPENDIX I Johnson Controls - MSDS

APPENDIX II Declaration of Conformity

Additional Documentation:

Battery Charger Manual

Flojet Product Data Sheet

This page left blank intentionally

## Lavatory Service Unit Parts List

When ordering replacement parts/kits, please specify model, serial number and color of your unit.

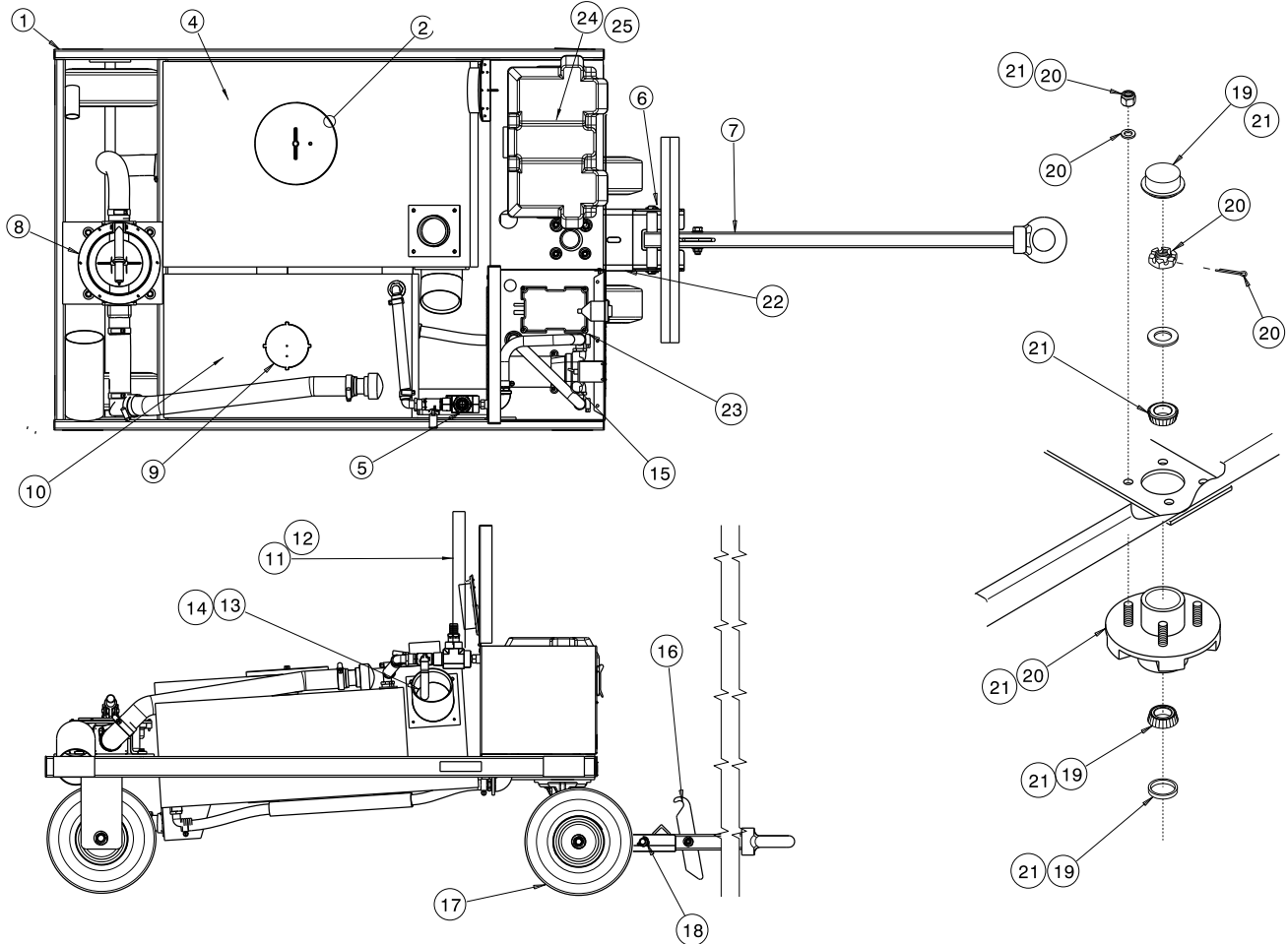

Item	Part Number	Description	Qty
1	Z-7204-01	Sub-Assembly, Lavatory Service Unit (includes Item 18)	1
2	K-4916	Kit, Fillwell Replacement	1
5	HC-1425-04	Valve, Ball	1
7	Z-5584-01	Weldment, Tongue	1
10	H-3302	Tank, 15 gallon Fill (includes Cover)	1
11	TF-1005*96.0	Hose, Fill 96" Long	1
18	G-1301-02	Pin, Cotter	2
22	Z-6182-01	Weldment, Steering Axle	1
23	EC-2215	Charger, Battery 50/60 Hz	1
24	EC-1656	Battery, 12 volt	1
25	H-1996	Box, Battery	1
4	<b>K-1209</b>	<b>Kit, Dump Tank Replacement; consists of:</b>	
	C-190-01	Tank, Dump	1
	G-1100-105010	Bolt, Hex Head, Grade 5, 1/4-20 x 1" long	4
	G-1178-103006	Screw, #10 Pan Head, Cross Recess Tapping	6
	G-1251-1050R	Lockwasher, 1/4 Regular	4
	H-1286	Cap, Plastic	1
	H-1426-16	Clamp Hose	1
	J-1403-02	Flange, Inner	1
	N-1505	Adapter, Male 2 PVC	1
	Z-1462	Weldment, Flanged Adapter, 4"	1
6	<b>K-3970</b>	<b>Kit, Pin Replacement; consists of:</b>	
	G-1301-02	Pin, 1/8" diameter x 1" long	2
	R-2096	Pin	1



### Lavatory Service Unit Parts List

Item	Part Number	Description	Qty
8	<b>K-4285</b>	<b>Kit, Discharge Pump Replacement; consists of:</b>	
	WC-1054	Pump, Guzzler	1
	G-1100-105010	Bolt, Hex Head, Grade 5, 1/4-20 x 1" long	4
	G-1202-1050	Stopnut, 1/4-20 Elastic	4
	G-1250-1050N	Flatwasher, 1/4 Narrow	4
9	<b>K-1688</b>	<b>Kit, Lid Replacement; consists of:</b>	
	H-1626	Cover	1
	H-1627	Gasket	1
12	<b>K-2410</b>	<b>Kit, Fill Connector Replacement; consists of:</b>	
	G-1351-04	Rivet, 1/8 Open-End Stl	1
	H-1424*12.0	Assembly, Lanyard	1
	H-1426-05	Clamp, Hose	1
	H-1954	Coupling, Fill	1
	N-2440-04-A	Plug, Coupling	1
13	<b>K-1210</b>	<b>Kit, 4" Flange Replacement; consists of:</b>	
	G-1100-105010	Bolt, Hex Head, Grade 5, 1/4-20 x 1" long	4
	G-1251-1050R	Lockwasher, 1/4 Regular	4
	H-1426-16	Clamp, Hose	2
	J-1403-02	Flange, Inner	1
	Z-1462	Weldment, 4" Flanged Adapter	1
14	<b>K-2029</b>	<b>Kit, Wye Coupling, 5' hose Replacement; consists of:</b>	
	H-1426-16	Clamp, Hose	1
	H-1768	Coupling, LSU Wye (Hose)	1
	TF-1001*60.0	Hose, 4" I.D. Dump	1
	V-1003	Label, Serial Number	1
15	<b>K-4339</b>	<b>Kit, Potable Water Pump Replacement; consists of:</b>	
	HC-2468	Pump, 4.5 gpm	1
	N-2862	Elbow	2
16	<b>K-3971</b>	<b>Kit, Lever Replacement; consists of:</b>	
	G-1100-109522	Bolt, Hex Head, Grade 5, 1/2-20 x 2 1/4" long	1
	G-1203-1095	Stopnut, 1/2-20 Elastic	1
	G-1250-1090N	Flatwasher, 1/2 Narrow	2
	J-3427	Lever	1
17	<b>K-1736</b>	<b>Kit, Wheel Replacement; consists of:</b>	
	G-1203-1115	Jamnut, 3/4-16 Elastic	1
	G-1250-1110N	Flatwasher, 3/4 Narrow	1
	U-1027	Wheel	1
19	<b>K-1253</b>	<b>Kit, Bearing/Seal Replacement; consists of:</b>	
	G-1301-03	Pin, 1/8 x 1 1/2" long, Cotter	1
	H-1155-01	Cap, Dust	1
	H-1559-01	Bearing	2
	H-1561-05	Seal, Grease	1
20	<b>K-1254</b>	<b>Kit, Hub Mounting Replacement; consists of:</b>	
	G-1100-109514	Bolt, Hex Head, Grade 5, 1/2-20 x 1-1/2" long	4
	G-1202-1095	Stopnut, 1/2-20 Elastic	4
	G-1250-1090N	Flatwasher, 1/2 Narrow	4
	G-1251-1090R	Lockwasher, 1/2 Regular	4
21	<b>K-1255</b>	<b>Kit, Hub Replacement; consists of:</b>	
	G-1202-1095	Stopnut, 1/2-20 Elastic	4
	G-1230-01	Nut, Axle (1"-14 UNS Thread)	1
	G-1250-1090N	Flatwasher, 1/2 Narrow	4
	G-1301-03	Pin, 1/8 x 1-1/2" long, Cotter	1
	H-1335	Hub, Idler	1

**Discharge Pump Assembly Component**

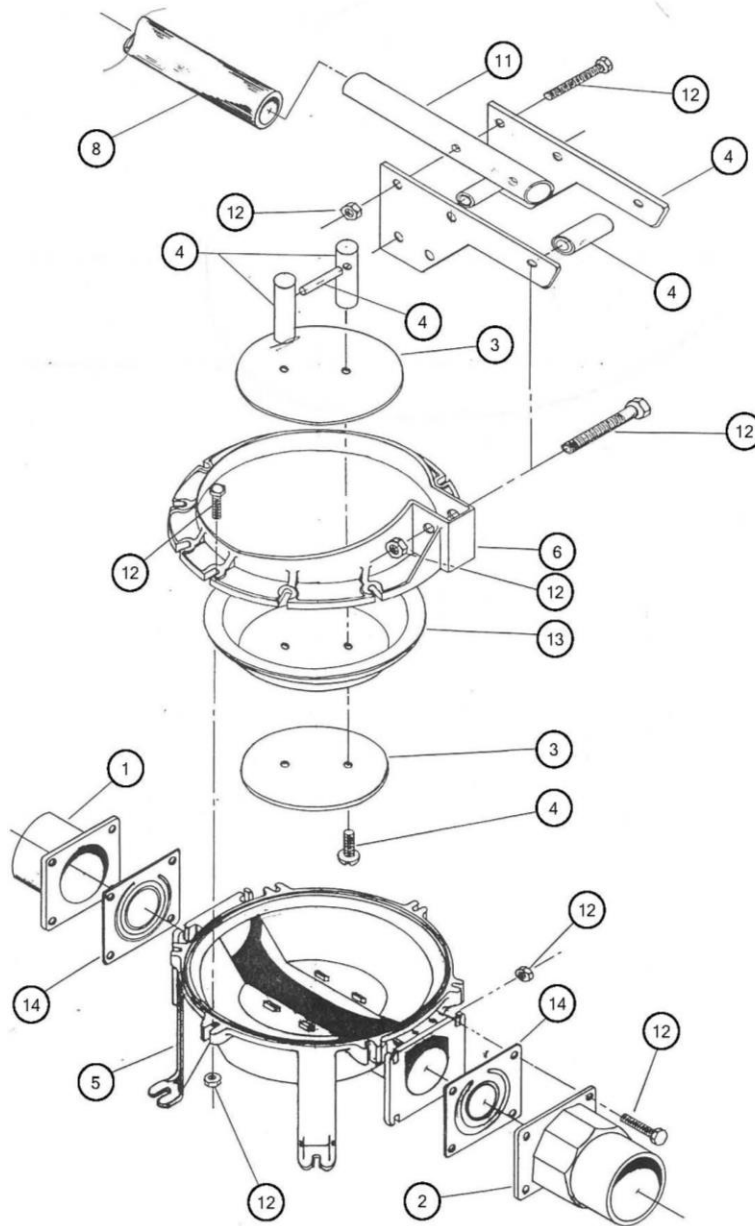

Item	Part Number	Description	Qty
	WC-1054	Pump Assembly	REF
1	WC-1054-01	Inlet Flange	1
2	WC-1054-02	Outlet Flange	1
3	WC-1054-03	Button	2
4	WC-1054-04	Clevis Assembly; <i>consists of:</i>	
	WC-1054-05	Clevis Pin	1
	WC-1054-06	Clevis Supports	2
	WC-1054-07	Side Plates	2
	WC-1054-08	Bushings A & B	2
	WC-1054-09	O-Rings #111	2
	WC-1054-10	SS Washers	2
	WC-1054-11	TH 1/4 - 20 x 5/8	2

**Pump Assembly Component**

Item	Part Number	Description	Qty
5	WC-1054-12	Body	1
6	WC-1054-13	Clamp Ring	1
8	WC-1054-14	Handle With Grip	1
11	WC-1054-15	Actuator Extension	1
12	WC-1054-16	Hardware Set; <i>Consists of:</i>	
	WC-1054-17	HH ¼ - 20 x 7/8 (Inlet/Outlet)	8
	WC-1054-18	HH ¼ - 20 x 1 (Clamp Ring)	6
	WC-1054-19	HN ¼ - 20	14
	WC-1054-20	HH 5/16 – 18 x 1 ¼ (Actuator)	2
	WC-1054-21	HN 5/16 – 18 (Actuator)	2
	WC-1054-22	HH 3/8 – 16 x 2 (Actuator)	1
	WC-1054-23	HN 3/8 – 16 (Actuator)	1
13	WC-1054-24	Diaphragm	1
14	WC-1054-25	Flapper Valves	2

**Discharge Pump Plumbing**

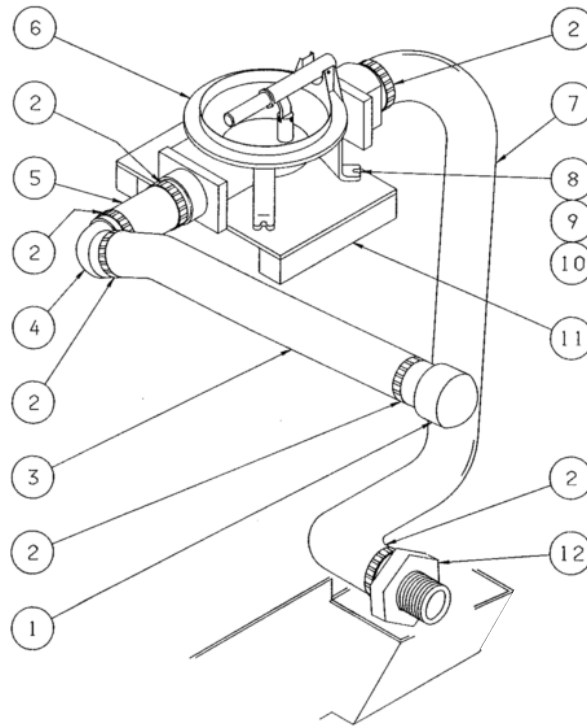

Item	Part Number	Description	Qty
1	H-1201	Cap	1
2	H-1426-09	Clamp, Hose, 2 inch	6
3	TF-1018-02*120	Hose, Discharge, 10 ft. long	1
4	N-1502	Elbow	1
5	TF-1006*04.5	Hose, 4½" long	1
7	TF-1018-02*21.0	Hose, 2" I.D.	1
8	G-1100-105010	Bolt, Hex Head, Grade 5, ¼-20 x 1" long	4
9	G-1202-1050	Stopnut, ¼-20 Elastic	4
10	G-1250-1050N	Flatwasher, ¼ Narrow	4
11	Z-1794	Weldment, Frame	REF
12	N-1505	Adapter, Male	2
6	<b>K-4285</b>	<b>Kit, Discharge Pump Replacement; consists of:</b>	
	WC-1054	Pump, Guzzler	1
	G-1100-105010	Bolt, Hex Head, Grade 5, 1/4-20 x 1" long	4
	G-1202-1050	Stopnut, 1/4-20 Elastic	4
	G-1250-1050N	Flatwasher, 1/4 Narrow	4

**NOTES:** 1. Kits contain all hardware necessary for installation.  
2. Unless otherwise stated, all replacement bolts should be Grade 5 or better.



## **APPENDIX I**

### **Safety Data Sheet (SDS) Johnson Controls Lead Acid Battery**



# Safety Data Sheet

## 1. IDENTIFICATION



<b>Product Name:</b> Lead Acid Battery <b>Synonyms:</b> SLI Battery	<b>Product Use:</b> Vehicle Electrical System <b>Manufacturer/Supplier:</b> Johnson Controls Battery Group <b>Address:</b> P.O. Box 590 Milwaukee, WI 53201 US
<b>General Information Number:</b> (800)-333-2222 ext. 3138 <b>Contact Person:</b> Industrial Hygiene & Safety Department	<b>Emergency number:</b> CHEMTREC: 800-424-9300

**NOTE:** The Johnson Controls sealed cell/battery is considered an article as defined by 29 CFR 1910.1200 (OSHA Hazard Communication Standard). The information contained in this SDS is supplied at the customer's request for information only.

## 2. HAZARD(S) IDENTIFICATION

Health		Environmental	Physical
Acute Toxicity (Oral, dermal, inhalation)	Category 4	Aquatic Chronic 1 Aquatic Acute 1	Explosive Chemical, Division 1.3
Skin corrosion/irritation	Category 1A		
Eye Damage	Category 1		
Reproductive	Category 1A		
Carcinogenicity (lead)	Category 1B		
Carcinogenicity (acid mist)	Category 1A		
Specific target organ toxicity (repeated exposure)	Category 2		

### Label Elements:

Health	Environmental	Physical
		
<b>Hazard Statements</b> <b>DANGER!</b> Causes severe skin burns and eye damage. Causes serious eye damage. May damage fertility or the unborn child if ingested or inhaled. May cause cancer if ingested or inhaled. Causes damage to central nervous system, blood and kidneys through prolonged or repeated exposure.	<b>Precautionary Statements</b> Wash thoroughly after handling. Do not eat, drink or smoke when using this product. Wear protective gloves/protective clothing, eye protection/face protection. Avoid breathing dust/fume/gas/mist/vapors/spray. Use only outdoors or in a well-ventilated area. Causes skin irritation, serious eye damage. Contact with internal components may cause irritation or severe burns. Avoid contact with internal acid. Irritating to eyes, respiratory system, and skin.	

May form explosive air/gas mixture during charging. Extremely flammable gas (hydrogen). Explosive, fire, blast or projection hazard.	
--	--

### 3. COMPOSITION / INFORMATION ON INGREDIENTS

INGREDIENTS (Chemical/Common Names):	CAS No.:	% by Wt:
Lead	7439-92-1	34
Lead Oxide	1309-60-0	31
Sulfuric Acid	7664-93-9	34
Lead Sulfate	7446-14-2	<1

Composition Comments

All concentrations are in percent by weight.

### 4. FIRST AID MEASURES

**Note: Under normal conditions of battery use, internal components will not present a health hazard. The following information is provided for battery electrolyte (acid) and lead for exposures that may occur during battery production or container breakage or under extreme heat conditions such as fire.**

<b>Inhalation</b>	Sulfuric Acid: Remove to fresh air immediately. If not breathing, give artificial respiration. If breathing is difficult, give oxygen. Consult a physician. Lead: Remove from exposure, gargle, wash nose and lips; consult physician.
<b>Skin contact</b>	Sulfuric Acid: Flush with large amounts of water for at least 15 minutes; remove contaminated clothing completely, including shoes. If symptoms persist, seek medical attention. Wash contaminated clothing before reuse. Discard contaminated shoes. Lead: Wash immediately with soap and water.
<b>Eye contact</b>	Sulfuric Acid and Lead: Flush immediately with large amounts of water for at least 15 minutes while lifting lids; Seek immediate medical attention if eyes have been exposed directly to acid.
<b>Ingestion</b>	Sulfuric Acid: Give large quantities of water; Do NOT induce vomiting or aspiration into the lungs may occur and can cause permanent injury or death; consult physician. Lead: Consult physician immediately.

### 5. FIRE FIGHTING MEASURES

<b>Flash Point</b>	Not applicable unless individual components exposed.
<b>Auto ignition Temperature</b>	No data available.
<b>Flammable Limits</b>	LEL = 4.1% (Hydrogen Gas in air) ; UEL = 74.2%
<b>Extinguishing Media</b>	CO2; foam; dry chemical. Do not use carbon dioxide directly on cells. Avoid breathing vapors. Use appropriate media for surrounding fire.
<b>Special Fire Fighting Procedures</b>	Use positive pressure, self-contained breathing apparatus. Beware of acid splatter during water application and wear acid-resistant clothing, gloves, face and eye protection. If batteries are on charge, shut off power to the charging equipment, but note that strings of series connected batteries may still pose risk of electric shock even when charging equipment is shut down.
<b>Unusual Fire and Explosion Hazard</b>	Highly flammable hydrogen gas is generated during charging and operation of batteries. If ignited by burning cigarette, naked flame or spark, may cause battery explosion with dispersion of casing fragments and corrosive liquid electrolyte. Carefully follow manufacturer's instructions for installation and service. Keep away all sources of gas ignition and do not allow metallic articles to simultaneously contact the negative and positive terminals of a battery. Follow manufacturer's instructions for installation and service.



## 6: ACCIDENTAL RELEASE MEASURES

<b>Protective Measures to be Taken if Material is Released or Spilled</b>	Stop flow of material, contain/absorb small spills with dry sand, earth, and vermiculite. Do not use combustible materials. If possible, carefully neutralize spilled electrolyte with soda ash, sodium bicarbonate, lime, etc. Wear acid-resistant clothing, boots, gloves, and face shield. Do not allow discharge of un-neutralized acid to sewer. Acid must be managed in accordance with approved local, state, and federal requirements. Consult state environmental agency and/or federal EPA.
<b>Waste Disposal Method</b>	Dispose of as a hazardous waste. Dispose of in accordance with applicable local, state and federal regulations.

## 7. HANDLING AND STORAGE

<b>Handling</b>	Unless involved in recycling operations, do not breach the casing or empty the contents of the battery. Handle carefully and avoid tipping, which may allow electrolyte leakage. There may be increasing risk of electric shock from strings of connected batteries. Keep containers tightly closed when not in use. If battery case is broken, avoid contact with internal components. Keep vent caps on and cover terminals to prevent short circuits. Place cardboard between layers of stacked automotive batteries to avoid damage and short circuits. Keep away from combustible materials, organic chemicals, reducing substances, metals, strong oxidizers and water. Use banding or stretch wrap to secure items for shipping.
<b>Storage</b>	Store batteries under roof in cool, dry, well-ventilated areas separated from incompatible materials and from activities that may create flames, spark, or heat. Store on smooth, impervious surfaces provided with measures for liquid containment in the event of electrolyte spills. Keep away from metallic objects that could bridge the terminals on a battery and create a dangerous short-circuit. Room ventilation is required for batteries utilized for standby power generation. Never recharge batteries in an unventilated, enclosed space.
<b>Charging:</b>	There is a possible risk of electric shock from charging equipment and from strings of series connected batteries, whether or not being charged. Shut-off power to chargers whenever not in use and before detachment of any circuit connections. Batteries being charged will generate and release flammable hydrogen gas. Charging space should be ventilated. Keep battery vent caps in position. Prohibit smoking and avoid creation of flames and sparks nearby. Wear face and eye protection when near batteries being charged.
<b>Other</b>	Follow Manufacturers Recommendations regarding maximum recommended currents and operating temperature range. Do not overcharge beyond the recommended upper charging voltage limit. Applying pressure or deforming the battery may lead to disassembly followed by eye, skin and throat irritation.

## 8. EXPOSURE CONTROLS / PERSONAL PROTECTION

### Occupational exposure limits

#### US OSHA Specifically Regulated Substances (29 CFR 1910.1001 – 1050)

Ingredient	CAS Number	Type	Value
Lead	7439-92-1	TWA	0.05 mg/m <sup>3</sup>
Lead Oxide	1309-60-0	TWA	0.05 mg/m <sup>3</sup>
Lead Sulfate	7446-14-2	TWA	0.05 mg/m <sup>3</sup>

#### US OSHA Table Z-1 Limits for Air Contaminants (29CFR 1910.1000)

Ingredient	CAS Number	Type	Value
Sulfuric Acid	7664-93-9	PEL	1 mg/m <sup>3</sup>

#### US ACGIH Threshold Limit Values

Ingredient	CAS Number	Type	Value	Form
Lead	7439-92-1	TWA	0.05 mg/m <sup>3</sup>	
Lead Oxide	1309-60-0	TWA	0.05 mg/m <sup>3</sup>	
Lead Sulfate	7446-14-2	TWA	0.05 mg/m <sup>3</sup>	
Sulfuric Acid	7664-93-9	TWA	0.2 mg/m <sup>3</sup>	Thoracic Fractions

**US NIOSH: Pocket Guide to Chemical Hazards**

Ingredient	CAS Number	Type	Value
Lead	7439-92-1	TWA	0.05 mg/m <sup>3</sup>
Lead Oxide	1309-60-0	TWA	0.05 mg/m <sup>3</sup>
Sulfuric Acid	7664-93-9	TWA	1 mg/m <sup>3</sup>

**International Exposure Limits (mg/m<sup>3</sup>)**

*Chemical & Common Name	Quebec PEV	Ontario OEL	EU OEL
Lead and Lead Compounds (inorganic)	0.05	0.05	0.15 (a)
Electrolyte (H <sub>2</sub> SO <sub>4</sub> /H <sub>2</sub> O)	1	0.2	0.05 (b)

(a) As inhalable aerosol (b) Thoracic fraction

**Biological limit values****ACGIH Biological Exposure Indices**

Ingredient	Value	Determinant	Specimen	Sampling Time
Lead	300 µg/l	Lead	Blood	*
Lead Oxide	300 µg/l	Lead	Blood	*
Lead Sulfate	300 µg/l	Lead	Blood	*

\* - For Sampling details please see the source document.

**Engineering Controls (Ventilation):**

Store and handle in well-ventilated area. If mechanical ventilation is used, components must be acid-resistant. Handle batteries cautiously, do not tip to avoid spills. Make certain vent caps are on securely. If battery case is damaged, avoid bodily contact with internal components. Wear protective clothing, eye and face protection, when filling, charging, or handling batteries. Do not allow metallic materials to simultaneously contact both the positive and negative terminals of the batteries. Charge batteries in areas with adequate ventilation. General dilution ventilation is acceptable.

**Respiratory Protection (NIOSH/MSHA approved):**

NONE REQUIRED FOR NORMAL HANDLING OF THE FINISHED PRODUCT.

When concentrations of sulfuric acid mist are known to exceed PEL, use NIOSH or MSHA-approved respiratory protection.

**Skin Protection:**

NONE REQUIRED FOR NORMAL HANDLING OF THE FINISHED PRODUCT.

If battery case is damaged, use rubber or plastic acid-resistant gloves with elbow-length gauntlet, acid-resistant apron, clothing and boots.

**Eye Protection:**

NONE REQUIRED FOR NORMAL HANDLING OF THE FINISHED PRODUCT.

If necessary to handle damage product where exposure to the organic electrolyte is a possibility, chemical splash goggles and a face shield are recommended.

**Other Protection:**

In areas where water and sulfuric acid solutions are handled in concentrations greater than 1%, emergency eyewash stations and showers should be provided, with unlimited water supply. Chemically impervious apron and face shield recommended when adding water or electrolyte to batteries. Wash Hands after handling.

**9. PHYSICAL AND CHEMICAL PROPERTIES**

<b>Appearance and Odor</b>	Manufactured article; no apparent odor. Electrolyte is a clear liquid with a sharp, penetrating, pungent odor.
<b>Odor Threshold</b>	Not applicable.
<b>pH</b>	Not applicable
<b>Boiling Point</b>	Not applicable unless individual components exposed.

	Battery Electrolyte (Acid) - 230 - 233.6 °F (110 - 112 °C)
	Lead - 3191 °F (1755 °C)
<b>Melting Point</b>	Lead - 621.32 °F (327.4 °C)
<b>Specific Gravity (H<sub>2</sub>O = 1)</b>	1.215 to 1.350
<b>Flash Point</b>	498.2 °F (259.0 °C) Hydrogen
<b>Evaporation Rate (Butyl Acetate = 1)</b>	< 1
<b>Vapor Pressure (mm Hg @ 20 ° C)</b>	Battery Electrolyte (Acid) 11.7
<b>Flammability</b>	
<b>Upper/lower flammability or explosive limits</b>	Hydrogen Flammability Limit Lower- 4.1 % Flammability Limit Upper – 74.2 %
<b>Vapor Pressure</b>	Not applicable.
<b>Vapor Density</b>	3.4 (Air = 1) Battery Electrolyte (Acid)
<b>Relative Density</b>	1.21 - 1.3 Battery Electrolyte (Acid)
<b>Solubility</b>	Lead and Lead dioxide are not soluble. 100 % Battery Electrolyte (Acid).
<b>% Volatile by Weight</b>	Not applicable unless individual components exposed.
<b>Partition coefficient (n-octanol/water)</b>	Not applicable
<b>Auto-ignition temperature</b>	1076 °F (580 °C) Hydrogen.
<b>Decomposition temperature</b>	Not applicable
<b>Viscosity</b>	Not applicable

## 10. STABILITY AND REACTIVITY

<b>Stability</b>	The sealed battery is considered stable.
<b>Conditions to Avoid</b>	Sparks and other sources of ignition; high temperature; over charging.
<b>Incompatibility (materials to avoid)</b>	Electrolyte: Contact with combustibles and organic materials may cause fire and explosion. Also reacts violently with strong reducing agents, metals, sulfur trioxide gas, strong oxidizers, and water. Contact with metals may produce toxic sulfur dioxide fumes and may release flammable hydrogen gas.  Lead compounds: Avoid contact with strong acids, bases, halides, halogenates, potassium nitrate, permanganate, peroxides, nascent hydrogen, and reducing agents.  Arsenic compounds: strong oxidizers; bromine azide. NOTE: hydrogen gas can react with inorganic arsenic to form the highly toxic gas – arsine
<b>Hazardous Decomposition Products</b>	Electrolyte: Sulfur trioxide, carbon monoxide, sulfuric acid mist, sulfur dioxide, hydrogen sulfide.  Lead compounds: Temperatures above the melting point are likely to produce toxic metal fume, vapor, or dust; contact with strong acid or base or presence of nascent hydrogen may generate highly toxic arsine gas.
<b>Hazardous Polymerization</b>	Will not occur.

## 11. TOXICOLOGICAL INFORMATION

**NOTE: Under normal conditions of use, this product does not present a health hazard. The following information is provided for organic electrolyte and lead exposure that may occur due to container breakage or under extreme conditions such as fire. Organic electrolyte – reacts with moisture/water to produce hydrofluoric acid in trace quantities. Hydrofluoric acid is extremely corrosive and toxic. In severe exposures it acts as a systemic poison and causes severe burns. The reaction may be delayed. Any contact with this material, even minor, requires immediate medical attention.**

#### ROUTES AND METHODS OF ENTRY

<b>Inhalation</b>	<b>EXPOSURE IS NOT EXPECTED FOR PRODUCT UNDER NORMAL CONDITIONS OF USE.</b>  Sulfuric Acid: Breathing of sulfuric acid vapors or mists may cause severe respiratory irritation. Lead Compounds: Inhalation of lead dust or fumes may cause irritation of upper respiratory tract and lungs.
<b>Skin Contact</b>	<b>EXPOSURE IS NOT EXPECTED FOR PRODUCT UNDER NORMAL CONDITIONS OF USE.</b>  Sulfuric Acid: Severe irritation, burns and ulceration. Lead Compounds: Not absorbed through the skin.
<b>Skin Absorption</b>	<b>EXPOSURE IS NOT EXPECTED FOR PRODUCT UNDER NORMAL CONDITIONS OF USE.</b>  In the event of overcharging or damage to the unit, exposure to organic electrolyte solution/mist is possible. Extreme exposures to the organic electrolyte can be absorbed through the skin.
<b>Eye Contact</b>	<b>EXPOSURE IS NOT EXPECTED FOR PRODUCT UNDER NORMAL CONDITIONS OF USE.</b>  Sulfuric Acid: Severe irritation, burns, cornea damage, and blindness. Lead Compounds: May cause eye irritation.
<b>Ingestion</b>	<b>EXPOSURE IS NOT EXPECTED FOR PRODUCT UNDER NORMAL CONDITIONS OF USE.</b>  Sulfuric Acid: May cause severe irritation of mouth, throat, esophagus and stomach. Lead Compounds: Acute ingestion may cause abdominal pain, nausea, vomiting, diarrhea and severe cramping. This may lead rapidly to systemic toxicity and must be treated by a physician.

#### SIGNS AND SYMPTOMS OF OVEREXPOSURE

<b>Acute Effects</b>	<b>EXPOSURE IS NOT EXPECTED FOR PRODUCT UNDER NORMAL CONDITIONS OF USE.</b>  Sulfuric Acid: Severe skin irritation, damage to cornea, upper respiratory irritation. Lead Compounds: Symptoms of toxicity include headache, fatigue, abdominal pain, loss of appetite, muscular aches and weakness, sleep disturbances and irritability
<b>Chronic Effects</b>	<b>EXPOSURE IS NOT EXPECTED FOR PRODUCT UNDER NORMAL CONDITIONS OF USE.</b>  Sulfuric Acid: Possible erosion of tooth enamel, inflammation of nose, throat & bronchial tubes. Lead Compounds: Anemia; neuropathy, particularly of the motor nerves, with wrist drop; kidney damage; reproductive changes in males and females. Repeated exposure to lead and lead compounds in the workplace may result in nervous system toxicity. Some toxicologists report abnormal conduction velocities in persons with blood lead levels of 50 µg/100 ml or higher. Heavy lead exposure may result in central nervous system damage, encephalopathy and damage to the blood-forming (hematopoietic) tissues.

#### MEDICAL CONDITIONS AGGRAVATED BY EXPOSURE

Overexposure to sulfuric acid mist may cause lung damage and aggravate pulmonary conditions. Contact of sulfuric acid with skin may aggravate diseases such as eczema and contact dermatitis. Lead and its compounds can aggravate some forms of kidney, liver and neurologic diseases.

#### ADDITIONAL HEALTH DATA

All heavy metals, including the hazardous ingredients in this product, are taken into the body primarily by inhalation and ingestion. Most inhalation problems can be avoided by adequate precautions such as ventilation and respiratory protection covered in Section 8. Follow good personal hygiene to avoid inhalation and ingestion: wash hands, face, neck and arms thoroughly before eating, smoking or leaving the work site. Keep contaminated clothing out of non-contaminated areas, or wear cover clothing when in such areas. Restrict the use and presence of food, tobacco and cosmetics to non-contaminated areas. Work clothes and work equipment used in contaminated areas must remain in designated areas and never taken home or laundered with personal non-contaminated clothing. This product is intended for industrial use only and should be isolated from children and their environment.

The 19th Amendment to EC Directive 67/548/EEC classified lead compounds, but not lead in metal form, as possibly toxic to reproduction. Risk phrase 61: May cause harm to the unborn child, applies to lead compounds, especially soluble forms.

#### Toxicological Data

Constituents	Species	Test Results
PS-HTR-ST-43-E_Lead Acid Battery		SDS US
Version #: 05 Issue Date: 04/01/2015 Revision Date: 03/16/2017		6 of 11

Sulfuric Acid (CAS 7664-93-9)

**Acute**

*Oral*

LD50

Rat

2140 mg/kg

#### **CARCINOGENICITY**

Sulfuric Acid: The International Agency for Research on Cancer (IARC) has classified "strong inorganic acid mist containing sulfuric acid" as a Category I carcinogen, a substance that is carcinogenic to humans. This classification does not apply to liquid forms of sulfuric acid or sulfuric acid solutions contained within a battery. Inorganic acid mist (sulfuric acid mist) is not generated under normal use of this product. Misuse of the product, such as overcharging, may result in the generation of sulfuric acid mist.

Lead Compounds: Lead is listed as a Group 2A- carcinogen, likely in animals at extreme doses. Per the guidance found in OSHA 29 CFR 1910.1200 Appendix F, this is approximately equivalent to GHS Category 1A. Proof of carcinogenicity in humans is lacking at present.

#### **IARC Monographs. Overall Evaluation of Carcinogenicity**

Lead (CAS 7439-92-1)

2A Probably carcinogenic to humans.

Lead oxide (CAS 1309-60-0)

2A Probably carcinogenic to humans.

Lead sulfate (CAS 7446-14-2)

2A Probably carcinogenic to humans.

#### **NTP Report on Carcinogens**

Lead oxide (CAS 1309-60-0)

Reasonably Anticipated to be a Human Carcinogen.

Lead sulfate (CAS 7446-14-2)

Reasonably Anticipated to be a Human Carcinogen.

#### **OSHA Specifically Regulated Substances (29 CFR 1910.1001-1050)**

Not listed.

#### **Reproductive toxicity**

May damage fertility or the unborn child.

#### **Specific target organ**

No data available.

#### **toxicity -**

#### **single exposure**

#### **Specific target organ**

Lead: May cause damage to organs (blood, central nervous system) through prolonged or repeated exposure.

#### **toxicity -**

#### **repeated exposure**

#### **Aspiration hazard**

Not classified.

### **12. ECOLOGICAL INFORMATION**

#### **Environmental Fate**

Lead is very persistent in soil and sediments. No data on environmental degradation. Mobility of metallic lead between ecological compartments is slow. Bioaccumulation of lead occurs in aquatic and terrestrial animals and plants but little bioaccumulation occurs through the food chain. Most studies include lead compounds and not elemental lead

#### **Environmental toxicity**

Aquatic Toxicity:

Sulfuric Acid

24-hr LC50, freshwater fish (Brachydanio rerio): 82 mg/L

96 hr- LOEC, freshwater fish (Cyprinus carpio): 22 mg/L

Lead

48 hr LC50 (modeled for aquatic invertebrates): <1 mg/L, based on lead bullion

#### **Additional Information**

No known effects on stratospheric ozone depletion

Volatile organic compounds: 0% (by Volume)

Water Endangering Class (WGK): NA

### **13. DISPOSAL CONSIDERATIONS**

#### **Waste disposal method**

Material should be recycled if possible. Lead-acid batteries are completely recyclable. Dispose waste and residues in accordance with applicable federal, state, and local regulations.

#### **Hazardous waste code**

D008: Lead

#### **Waste from residues / unused products**

Dispose of in accordance with local regulations. Empty containers or packaging may retain some product residues. This material and its container must be disposed of in a safe manner (see: Disposal instructions).

**Contaminated packaging** Empty containers should be taken to an approved waste handling site for recycling or disposal.

## 14. TRANSPORT INFORMATION

**Note:** Transportation requirements do not apply once the battery pack has been installed in a vehicle as part of the vehicle's functional components.

### United States DOT:

DOT rules specified in 49 CFR 173.159 regulate the transport of wet spillable batteries.

49 CFR 173.159 (e) specifies that when transported by highway or rail, electric storage batteries containing electrolyte or corrosive battery fluid are not subject to any other requirements of this subchapter, if all of the following are met:

- (1) No other hazardous materials may be transported in the same vehicle;
- (2) The batteries must be loaded or braced so as to prevent damage and short circuits in transit;
- (3) Any other material loaded in the same vehicle must be blocked, braced, or otherwise secured to prevent contact with or damage to the batteries; and
- (4) The transport vehicle may not carry material shipped by any person other than the shipper of the batteries.

If any of these requirements are not met, the batteries must be shipped as hazardous materials

### GROUND – US-DOT/CAN-TDG/EU-ADR/APEC-ADR:

<b>Proper Shipping name</b>	Batteries, Wet, Filled with Acid
<b>UN number</b>	UN2794
<b>Hazard classification</b>	8
<b>Packing group</b>	N/A
<b>Labels</b>	Corrosive

### AIRCRAFT – ICAO-IATA:

<b>Proper Shipping name</b>	Batteries, Wet, Filled with Acid
<b>Packing group</b>	None
<b>Hazardous class</b>	8
<b>Label/Placard Required</b>	Corrosive
<b>UN Identification</b>	UN2794
<b>Environmental Hazards</b>	No
<b>ERG Code</b>	8L
<b>Reference</b>	IATA packing instructions 870 (IATA DRG Edition 54)

### VESSEL – IMO-IMDG:

<b>Proper Shipping name</b>	Batteries, Wet, Filled with Acid
<b>Packing group</b>	N/A
<b>Hazardous class</b>	8
<b>Label/Placard Required</b>	Corrosive
<b>UN Identification</b>	UN2794
<b>Environmental Hazards</b>	No
<b>EmS</b>	F-A, S-B
<b>Reference</b>	IMDG packing instructions P801

## 15. REGULATORY INFORMATION

This product is an article pursuant to 29 CFR 1910.1200 and as such is not subjected to the OSHA Hazard Communication Standard.

### TSCA

#### TSCA Section 8b – Inventory Status:

Inventory Status: All chemicals comprising this product are either exempt or listed on the TSCA Inventory.

#### TSCA Section 12b (40 CFR Part 707.60(b))

No notice of export will be required for articles, except PCB articles, unless the Agency so requires in the context of individual section 5, 6, or 7 actions.

**TSCA Section 13 (40 CFR Part 707.20)**

No import certification required (EPA 305-B-99-001, June 1999, Introduction to the Chemical Import Requirements of the Toxic Substances Control Act, Section IV.A)

**OSHA Specifically Regulated Substances (29 CFR 1910.1001-1050)**

Lead (CAS 7439-92-1)	Reproductive toxicity Central nervous system Kidney Blood
Lead Oxide (CAS 1309-60-0)	Acute toxicity Reproductive toxicity Central nervous system Kidney Blood
Lead Sulfate (CAS 7446-14-2)	Acute toxicity Reproductive toxicity Central nervous system Kidney Blood Acute toxicity

**EPA SARA Title III****Section 302 EPCRA Extremely Hazardous Substances (EHS):**

Sulfuric acid is a listed "Extremely Hazardous Substance" under EPCRA, with a Threshold Planning Quantity (TPQ) of 1,000 lbs. EPCRA Section 302 notification is required if 500 lbs. or more of sulfuric acid is present at one site (40 CFR 370.10). For more information consult 40 CFR Part 355.

**Section 304 CERCLA Hazardous Substances:**

Reportable Quantity (RQ) for spilled 100% sulfuric acid under CERCLA (Superfund) and EPCRA (Emergency Planning and Community Right to Know Act) is 1,000 lbs. State and local reportable quantities for spilled sulfuric acid may vary.

**Section 311/312 Hazard Categorization:**

EPCRA Section 312 Tier Two reporting is required for non-automotive batteries if sulfuric acid is present in quantities of 500 lbs. or more and/or if lead is present in quantities of 10,000 lbs. or more. For more information consult 40 CFR 370.10 and 40 CFR 370.40

**Section 313 EPCRA Toxic Substances:**

40 cfr section 372.38 (b) states: If a toxic chemical is present in an article at a covered facility, a person is not required to consider the quantity of the toxic chemical present in such article when determining whether an applicable threshold has been met under § 372.25, § 372.27, or § 372.28 or determining the amount of release to be reported under § 372.30. This exemption applies whether the person received the article from another person or the person produced the article. However, this exemption applies only to the quantity of the toxic chemical present in the article.

**Supplier Notification:**

This product contains toxic chemicals that may be reportable under EPCRA Section 313 Toxic Chemical Release Inventory (Form R) requirements. For a manufacturing facility under SIC codes 20 through 39, the following information is provided to enable you to complete the required reports:

**RCRA**

Spent Lead Acid Batteries are subject to streamlined handling requirements when managed in compliance with 40 CFR section 266.80 or 40 CFR part 273. Waste sulfuric acid is a characteristic hazardous waste; EPA hazardous waste number D002 (corrosivity) and D008 (lead).

**Other federal regulations****Clean Air Act (CAA) Section 112 Hazardous Air Pollutants (HAPs) List**

Lead (CAS 7439-92-1)  
Lead Oxide (CAS 1309-60-0)  
Lead Sulfate (CAS 7446-14-2)

**Clean Air Act (CAA) Section 112(r) Accidental Release Prevention (40 CFR 68.130)**

Lead Sulfate (CAS 7446-14-2)

**Safe Drinking Water Act (SDWA)**

Not regulated

**Drug Enforcement Administration (DEA). List 2, Essential Chemicals (21 CFR 1310.02(b) and 1310.04(f)(2) and Chemical Code Number**

Sulfuric acid (CAS 7664-93-9) 6552

**Drug Enforcement Administration (DEA). List 1 & 2 Exempt Chemical Mixtures (21 CFR 1310.12(c))**

Sulfuric acid (CAS 7664-93-9) 20 % WV

**DEA Exempt Chemical Mixtures Code Number**

Sulfuric acid (CAS 7664-93-9) 6552

**US State Regulations**

**US. Massachusetts RTK – Substance List**

Lead ( CAS 7439-92-1)

Lead Oxide (CAS 1309-60-0)

Lead Sulfate (CAS 7446-14-2)

**US New Jersey Worker and Community Right-to-know Act**

Lead ( CAS 7439-92-1)

Lead Oxide (CAS 1309-60-0)

Lead Sulfate (CAS 7446-14-2)

Sulfuric acid (CAS 7664-93-9)

**US Pennsylvania Worker and Community Right-to-know Law**

Lead ( CAS 7439-92-1)

Sulfuric acid (CAS 7664-93-9)

**US Rhode Island RTK**

Lead ( CAS 7439-92-1)

Lead Oxide (CAS 1309-60-0)

Lead Sulfate (CAS 7446-14-2)

Sulfuric acid (CAS 7664-93-9)

**US. California Proposition 65**

WARNING: This product contains chemicals known to the State of California to cause cancer.

Battery posts, terminals and related accessories contain lead and lead compounds, chemicals known to the state of California to cause cancer and reproductive harm. Wash hands after handling.

\*Battery companies not party to the 1999 consent judgment with Mateel Environmental Justice Foundation should include a Proposition 65 Warning that complies with the current version of Proposition 65.

**US - California Proposition 65 - Carcinogens & Reproductive Toxicity (CRT): Listed substance**

Lead ( CAS 7439-92-1)

Lead Oxide (CAS 1309-60-0)

Lead Sulfate (CAS 7446-14-2)

Sulfuric acid (CAS 7664-93-9)

**International Inventories**

Country(s) or Region	Inventory Name	On inventory (yes/no)*
United States & Puerto Rico	Toxic Substances Control Act (TSCA) Inventory	Yes

\* A "Yes" indicates this product complies with the inventory requirements administered by the governing country(s).

A "No" indicates that one or more components of the product are not listed or exempt from listing on the inventory administered by the governing country(s).

**CANADIAN ENVIRONMENTAL PROTECTION ACT:** These products are manufactured articles and are exempt from regulation.

**CANADIAN WHMIS CLASSIFICATION:** This product has been classified according to the hazard criteria of the CPR and the MSDS contains all the information required by the CPR.

## 16. OTHER INFORMATION

**Issue Date:** 04/01/2015

**Further information:** NFPA Hazard Scale: 0 = Minimal 1 = Slight 2 = Moderate 3=Serious 4 = Severe



**NFPA ratings**

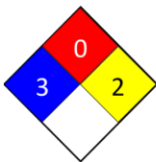

**Disclaimer**

Johnson Controls Battery Group, Inc. cannot anticipate all conditions under which this information and its product, or the products of other manufacturers in combination with its product, may be used. It is the user's responsibility to ensure safe conditions for handling, storage and disposal of the product, and to assume liability for loss, injury, damage or expense due to improper use. The information in the sheet was written based on the best knowledge and experience currently available.





## APPENDIX II

### Declaration of Conformity





## DECLARATION of CONFORMITY

The design, development and manufacture is in accordance with European Community guidelines

Electric Lavatory Service Unit  
10-6408-0000

Relevant provisions complied with by the machinery:  
2006/42/EC

Relevant standards complied with by the machinery:  
EN ISO 12100-1

Identification of person empowered to sign on behalf of the Manufacturer:

A handwritten signature in cursive script that reads "Patrick Finch". The signature is written in black ink and is positioned above a horizontal line.

Quality Assurance Representative