

**Models: 11-6644C1010  
11-6644C1010-A1  
Gasoline Ground Power Units**



08/2023 – Rev. 08

**For Spare Parts, Operations & Service Manuals or Service Needs  
Scan the QR code or visit [Tronair.com/aftermarket](http://Tronair.com/aftermarket)**



| REVISION | DATE    | TEXT AFFECTED       |
|----------|---------|---------------------|
| OR       | 01/2007 | Original Release    |
| 01       | 11/2008 | Modified Parts List |
| 02       | 04/2012 | Modified Parts List |
| 03       | 03/2017 | Major revision      |
| 04       | 06/2017 | Modified Parts List |
| 05       | 01/2018 | Modified Parts List |
| 06       | 12/2020 | Modified Parts List |
| 04       | 06/2017 | Modified Parts List |
| 05       | 01/2018 | Modified Parts List |
| 06       | 12/2020 | Modified Parts List |
| 07       | 12/2022 | Modified Parts List |
| 08       | 08/2023 | Modified Parts List |

**TABLE OF CONTENTS**

**PAGE**

|            |  |           |
|------------|--|-----------|
| <b>1.0</b> | <b>PRODUCT INFORMATION .....</b>                               | <b>1</b>  |
| 1.1        | DESCRIPTION.....   | 1         |
| 1.2        | MODEL & SERIAL NUMBER.....                                     | 1         |
| 1.3        | MANUFACTURER.....  | 1         |
| <b>2.0</b> | <b>SAFETY INFORMATION.....</b>                                 | <b>1</b>  |
| 2.1        | USAGE AND SAFETY INFORMATION.....                              | 1         |
| 2.2        | EXPLANATION OF WARNING & DANGER SIGNS.....                     | 1         |
| 2.3        | COMPONENT SAFETY FEATURES.....                                 | 2         |
| 2.4        | FUNCTIONAL SAFETY FEATURES.....                                | 2         |
| 2.5        | FEATURES FOR OPERATOR SAFETY.....                              | 2         |
| 2.6        | PROTECTION SYSTEMS.....  | 2         |
| 2.7        | CLOSED CIRCUITS.....   | 2         |
| 2.8        | INTERLOCKING.....  | 2         |
| 2.9        | PERSONAL PROTECTIVE EQUIPMENT.....                             | 2         |
| 2.10       | SAFETY GUIDELINES.....   | 2         |
| 2.11       | OPERATOR QUALIFICATIONS.....                                   | 2         |
| 2.11.1     | Installation/Maintenance/Dismantling Qualifications.....       | 2         |
| 2.12       | ADDITIONAL SAFETY MEASURES.....                                | 2         |
| <b>3.0</b> | <b>TRAINING.....</b>   | <b>3</b>  |
| 3.1        | TRAINING REQUIREMENTS.....                                     | 3         |
| 3.2        | TRAINING PROGRAM.....  | 3         |
| 3.3        | OPERATOR TRAINING.....   | 3         |
| <b>4.0</b> | <b>ASSEMBLY.....</b>   | <b>3</b>  |
| 4.1        | GENERAL INFORMATION.....                                       | 3         |
| 4.2        | ASSEMBLY STEPS.....  | 3         |
| <b>5.0</b> | <b>INSTALLATION.....</b>                                       | <b>4</b>  |
| <b>6.0</b> | <b>OPERATION.....</b>  | <b>4</b>  |
| 6.1        | OPERATING PARAMETERS.....                                      | 4         |
| 6.2        | NUMERICAL VALUES.....  | 4         |
| 6.2.1      | Ground Power Unit.....   | 4         |
| 6.2.2      | Engine.....  | 4         |
| 6.2.3      | Alternator.....  | 4         |
| 6.2.4      | Batteries.....   | 5         |
| 6.2.5      | Chassis.....   | 5         |
| 6.3        | LOCATION AND LAYOUT OF CONTROLS.....                           | 6         |
| 6.3.1      | Instrumentation and Controls.....                              | 6         |
| 6.4        | PREPARATION PRIOR TO FIRST USE.....                            | 7         |
| 6.4.1      | General.....   | 7         |
| 6.4.2      | Pre-Start.....   | 7         |
| 6.4.3      | Oil Recommendations.....                                       | 7         |
| 6.4.4      | Fuel Recommendations.....                                      | 7         |
| 6.5        | PERSONAL PROTECTIVE EQUIPMENT.....                             | 7         |
| 6.6        | CHECKS PRIOR TO START UP.....                                  | 7         |
| 6.7        | START UP PROCEDURE.....  | 8         |
| 6.7.1      | Battery Disconnect Switch.....                                 | 8         |
| 6.7.2      | Contact Power Switch.....                                      | 8         |
| 6.7.3      | Throttle Switch.....   | 8         |
| 6.7.4      | Emergency Stop Switch.....                                     | 8         |
| 6.7.5      | Engine Key Switch.....   | 8         |
| 6.7.6      | Engine Starter (Start engine).....                             | 8         |
| 6.7.7      | Warm Engine at Idle.....                                       | 8         |
| 6.7.8      | Throttle to "Run" Position.....                                | 8         |
| 6.7.9      | Check Current to Batteries; 28 Amps or less is Normal.....     | 8         |
| 6.7.10     | Unit Is Now Ready to Provide Electrical Power to Aircraft..... | 8         |
| 6.8        | OPERATING PROCEDURES.....                                      | 9         |
| 6.9        | SHUT OFF/SHUTDOWN PROCEDURES.....                              | 9         |
| 6.9.1      | Aircraft Power Cable Switch "Off".....                         | 9         |
| 6.9.2      | Run Unit Until Battery Current Drops to 28 amps or less.....   | 9         |
| 6.9.3      | Throttle to Idle.....  | 9         |
| 6.9.4      | Engine Key Switch to "Off".....                                | 9         |
| 6.10       | EMERGENCY SHUTDOWN PROCEDURES.....                             | 9         |
| 6.11       | DESCRIPTION OF ALARM SYSTEMS.....                              | 9         |
| 6.11.1     | High Oil Temperature Lamp.....                                 | 9         |
| <b>7.0</b> | <b>PACKAGING AND STORAGE.....</b>                              | <b>10</b> |
| 7.1        | PACKAGING REQUIREMENTS.....                                    | 10        |

|             |   |           |
|-------------|---|-----------|
| 7.2         | HANDLING .....                                  | 10        |
| 7.3         | PACKAGING PROTECTION .....                      | 10        |
| 7.4         | LABELING OR PACKAGING .....                     | 10        |
| 7.5         | STORAGE COMPATIBILITY .....                     | 10        |
| 7.6         | STORAGE ENVIRONMENT .....                       | 10        |
| 7.7         | STORAGE SPACE AND HANDLING FACILITIES .....     | 10        |
| <b>8.0</b>  | <b>TRANSPORTATION .....</b>                     | <b>10</b> |
| <b>9.0</b>  | <b>TROUBLE SHOOTING .....</b>                   | <b>11</b> |
| <b>10.0</b> | <b>MAINTENANCE .....</b>                        | <b>12</b> |
| 10.1        | GENERAL .....                                   | 12        |
| 10.2        | ENGINE .....                                    | 12        |
| 10.3        | ALTERNATOR .....                                | 12        |
| 10.4        | BATTERIES .....                                 | 12        |
| 10.5        | CHASSIS .....                                   | 12        |
| 10.6        | AIRCRAFT POWER CABLE .....                      | 12        |
| <b>11.0</b> | <b>PROVISION OF SPARES .....</b>                | <b>13</b> |
| 11.1        | SOURCE OF SPARE PARTS .....                     | 13        |
| 11.2        | RECOMMENDED SPARE PARTS LISTS .....             | 13        |
| <b>12.0</b> | <b>IN-SERVICE SUPPORT .....</b>                 | <b>13</b> |
| <b>13.0</b> | <b>GUARANTEES/LIMITATION OF LIABILITY .....</b> | <b>13</b> |
| <b>14.0</b> | <b>APPENDICES .....</b>                         | <b>13</b> |

This product can not be modified without the written approval of Tronair, Inc. Any modifications done without written approval voids all warranties and releases Tronair, Inc., its suppliers, distributors, employees, or financial institutions from any liability from consequences that may occur. Only Tronair OEM replacement parts shall be used.

## 1.0 PRODUCT INFORMATION

### 1.1 DESCRIPTION

This Tronair Ground Power Unit (GPU) is a completely portable, self-contained, 28 volt DC unit. See name label for serial number and date of manufacture.

Electrical power is generated by a heavy-duty industrial 24v/150amp alternator, driven by a 18 hp gasoline engine. Six (6) 12 volt high cycle lead calcium batteries are used to provide peak and transient power and “soft start” characteristics.

The alternator provides continuous electrical power up to 150 amps for both aircraft use and GPU battery recharging. The six 12 volt batteries are grouped to provide 28 VDC power. See Figure 3 – Electrical Schematic.

A number 32 lunette eye is provided for connecting to standard towing equipment.

### 1.2 MODEL & SERIAL NUMBER

Reference nameplate on unit

### 1.3 MANUFACTURER

**TRONAIR**, Inc.  
1 Air Cargo Pkwy East  
Swanton, Ohio 43558 USA

Telephone: (419) 866-6301 or 800-426-6301  
Fax: (419) 867-0634  
E-mail: sales@tronair.com  
Website: www.tronair.com

## 2.0 SAFETY INFORMATION

### 2.1 USAGE AND SAFETY INFORMATION

To insure safe operations please read the following statements and understand their meaning. Also refer to your equipment manufacturer’s manual for other important safety information. This manual contains safety precautions which are explained below. Please read carefully.



**WARNING!** — Warning is used to indicate the presence of a hazard that **can cause severe personal injury, death, or substantial property damage** if the warning notice is ignored.

**CAUTION!** — Caution is used to indicate the presence of a hazard that **will or can cause minor personal injury or property damage** if the caution notice is ignored.

This Tronair GPU provides regulated 28.0 VDC electrical power for aircraft starting and electrical service.

### 2.2 EXPLANATION OF WARNING & DANGER SIGNS



**WARNING!** — Warning is used to indicate the presence of a hazard that **can cause severe personal injury, death, and/or substantial property damage** if the warning notice is ignored.

**CAUTION!** — Caution is used to indicate the presence of a hazard that **will or can cause minor personal injury or property damage** if the caution notice is ignored.



**Accidental Starts!** Before servicing the engine or equipment, always disconnect the positive lead to the battery to prevent the engine from starting accidentally. Wrap the end of leads to prevent sparks.

Disconnect both 12V and 28V positive leads to batteries prior to working in either the engine or battery compartments.



**Rotating Parts!** Keep hands, feet, hair and clothing away from all moving parts to prevent personal injury. Never operate the engine with covers, shrouds, and/or guards removed.



**Hot Parts!** Engine components can get extremely hot from operation. To prevent severe burns, do not touch engine components while engine is running or immediately after is shut down. Never operate the engine with heat shields or guards removed.



**Explosive Fuel!** Gasoline fuel is extremely flammable and its vapors can explode if ignited. Store fuel only in approved containers, in well-ventilated, unoccupied buildings, away from sparks or flames. Do not fill the fuel tank while the engine is hot or running as spilled fuel could ignite if it comes in contact with hot parts or sparks from ignition. Do not start the engine near spilled fuel. Never use fuel as a cleaning agent.

## 2.2 EXPLANATION OF WARNING & DANGER SIGNS *(continued)*



**Lethal Exhaust Gases!** Engine exhaust gases contain poisonous carbon monoxide. Carbon monoxide is odorless, colorless, and can cause death if inhaled. Avoid inhaling exhaust fumes and never run the engine in a closed building or confined area.



**Explosive Gas!** Batteries produce explosive hydrogen gas while being charged. To prevent a fire or explosion, charge batteries only in well ventilated areas. Keep sparks, open flames and other sources of ignition away from the battery at all times. Keep batteries out of the reach of children. Remove all jewelry when servicing batteries. Before disconnecting the negative (-) ground cable, ensure all switches are "Off". If "On", a spark will occur at the ground cable terminal which could cause an explosion if hydrogen gas or fuel vapors are present.



**Electrical Shock!** Never touch electrical wires or components while the engine is running. Electrical wires can be sources of electrical shock.

Do not operate GPU with cabinet panels removed.



**Flammable Solvents!** Carburetor cleaners and solvents are extremely flammable. Keep sparks, flames and other sources of ignition away from the area. Follow the cleaner/solvent manufacturer's warnings and instructions on its proper and safe use. Never use fuel as a cleaning agent.

## 2.3 COMPONENT SAFETY FEATURES

- Electrical Emergency Stop
- Full enclosure
- Aircraft supply circuit fusing
- Electrical Power Output Interlock
- Towbar Wheel Brake

## 2.4 FUNCTIONAL SAFETY FEATURES

- Ignition switch controls power to alternator, starter and aircraft power interlock circuit.
- Aircraft power selector switch controls output power of aircraft power cable.
- In the event of an emergency, emergency stop can be pushed in to de-energize the electrical system and stop the engine.

## 2.5 FEATURES FOR OPERATOR SAFETY

See sections 2.3 and 2.4.

## 2.6 PROTECTION SYSTEMS

- Output power fast acting fuse 800A
- Throttle solenoid fuse 10A

## 2.7 CLOSED CIRCUITS

See Wiring Diagram

## 2.8 INTERLOCKING

The output power cable must be plugged into the aircraft for the output selector switch to operate. In the event the cable becomes disconnected from the aircraft, contactor will drop out and no output power will be available.

## 2.9 PERSONAL PROTECTIVE EQUIPMENT

Safety glasses and ear protection must be worn when operating the equipment.

## 2.10 SAFETY GUIDELINES

- Contactor switch must be in off position while connecting cable to the aircraft.
- Aircraft power cable switch must be switched "Off" before cable is being disconnected from aircraft.

## 2.11 OPERATOR QUALIFICATIONS

This unit is intended to be operated by personnel trained in its proper use in conjunction with the intended aircraft.

### 2.11.1 Installation/Maintenance/Dismantling Qualifications

This unit is to be installed, maintained and dismantled by qualified technicians familiar with battery/alternator charging systems and gasoline powered internal combustion ignition engines.

## 2.12 ADDITIONAL SAFETY MEASURES

This Ground Power Unit must be used in accordance with the Tronair Operation and Service manual and in accordance with the aircraft manufacturer's instructions.

### 3.0 TRAINING

#### 3.1 TRAINING REQUIREMENTS

The employer of the operator is responsible for providing a training program sufficient for the safe operation of the Ground Power Unit.

#### 3.2 TRAINING PROGRAM

The employer-provided operator training program should cover safety procedures concerning use of the Ground Power Unit in and around the intended aircraft at the intended aircraft servicing location.

#### 3.3 OPERATOR TRAINING

The operator training should provide the required training for safe operation of the Ground Power Unit.

**NOTE: Maintenance and Trouble Shooting are to be performed by the skilled and trained technician.**

### 4.0 ASSEMBLY

#### 4.1 GENERAL INFORMATION

This product should be assembled and/or repaired using good workmanship practices and proper tools. Bolts and elastic stopnuts should be tightened to a torque not to exceed industry standards of Grade '5' bolts.

| BOLT TORQUE |        |     | SAE Classification<br>Grade 5<br><br>Markings on top of bolt head<br>indicate grade. |
|-------------|--------|-----|---|
| Size        | Ft-lbs | N-m |   |
| 5/16 - 24   | 20     | 27  |   |
| 3/8 - 24    | 35     | 47  |   |
| 1/2 - 20    | 85     | 115 |   |

All replacement parts must be the same as or equal to the original parts supplied.

#### 4.2 ASSEMBLY STEPS

1. Generally check over unit and ensure the tightness of all nuts, bolts and screws.
2. Check tire pressure for 55 psi (3.9 bar) maximum.
3. Engine System:
  - a. Check the engine oil level.
  - b. Check tension of alternator drive belts.
  - c. Fill fuel tank with gasoline.
4. Electrical Hook-up.

#### WARNING!



**Battery posts, terminals and related accessories contain lead and lead compounds; chemicals known to the State of California to cause cancer and reproductive harm.**

**Wash hands after handling batteries and related accessories.**

#### CAUTION!



**Be sure that all control panel switches and battery disconnect is in the "Off" position before making battery connections.**

- a. Remove battery tray.
- b. Attach positive 28 V battery bank cable labeled "(+) BATTERY LEAD" to location labeled "(+) CONNECTION POINT".
- c. Attach negative 28V battery bank cable labeled "(-) BATTERY LEAD" to location labeled "(-) CONNECTION POINT".

#### WARNING!



**Use extreme caution when working inside the access panels. Electrical shock may occur.**

## 5.0 INSTALLATION

Refer to aircraft manufacturer's procedure for connection to aircraft and aircraft external power source requirements.

## 6.0 OPERATION

### 6.1 OPERATING PARAMETERS

- The user shall use the Ground Power Unit in accordance with the aircraft manufacturer's instructions.
- The user shall work in accordance with the Technical and Operator Manuals.
- The employer of the operator of the Ground Power Unit shall provide for all necessary training.

### 6.2 NUMERICAL VALUES

#### 6.2.1 Ground Power Unit

|  |                                    |
|--|------------------------------------|
| Output .....   | 150 amps continuous @ 28.5 VDC     |
|  | 1000 amps peak                     |
| Width .....  | 47 in (120 cm)                     |
| Length – 11-6644C1010.....   | 60.5 in (154 cm)                   |
| Length – 11-6644C1010-A1 .....   | 72 in (183 cm)                     |
| Height.....  | 46 in (116 cm)                     |
| Weight.....  | 1,300 lbs (590 kg)                 |
| Maximum Towing Speed.....  | 10 mph (16 km/hr)                  |
| Charging Temperature Range.....  | 0° F to 125° F (-18° C to 52° C)   |
| Aircraft Starting & Electrical Service Temperature Range.....          | -20° F to 125° F (-29° C to 52° C) |
| Maximum Operating Temperature.....                                     | 167° F (75° C)                     |
| 20 foot MIL-C-5756B 4/0 Aircraft power cable with AN2551 E20 connector |                                    |

#### 6.2.2 Engine

- Kohler, 2 cylinder, air-cooled, gasoline engine
- 18 hp (13 kW) @ 3,000 rpm
- High Oil Temperature Switch
- Low oil pressure shut-down
- Fuel ..... 13.00 U.S. gallons (49.2 lt) gasoline
- Oil Sump ..... 2.6 U.S. quarts (2.5 lt)
- Air Cleaner ..... Replacement Dry Type
- Fuel Specifications:
  - Do not add oil to the gasoline
  - Do not overfill the fuel tank, leave room for the fuel to expand
  - Fuel Type: For best results use only clean, fresh, unleaded gasoline with a pump sticker octane rating of 87 or higher (In countries using the Research method, it should be 90 octane or higher)
  - Gasoline/Alcohol Blends: gasohol (up to 10% ethyl alcohol, 90% unleaded gasoline by volume) is approved as a fuel for Kohler engines. Other gasoline/alcohol blends are not approved
  - Gasoline/Ether Blends: Methyl Tertiary Butyl Ether (MTBE) and unleaded gasoline blends (up to a maximum of 15% MTBE by volume) are approved as a fuel for Kohler engines. Other gasoline/ether blends are not approved

#### 6.2.3 Alternator

- Heavy-duty, long service life
- Rated @ 150 amps
- Internal regulator with load dump protection
- Diode trio regulation and indicator light circuit
- Voltage regulation:
  - 26.8 to 28.0 VDC (System set at approximately 28 VDC)
  - Fully transistorized
  - Epoxy filled
  - Temperature compensated
- Silicone devices for operation at high ambient conditions
- Bi-directional fan
- Front ball bearing and rear roller bearing
- Baffled air inlet to reduce contaminants
- Dynamically balanced rotor
- Stator epoxy-coated and varnished for insulation and environmental protection



**6.2.4 Batteries**

Six (6) 12 volt, high cycle, lead calcium

Group size ..... 31

Reserve Capacity ..... 170 minutes

Cold-cranking amps (0° F) ..... 1025 A each

Terminals ..... Stainless Steel threaded stud

**6.2.5 Chassis**

Welded steel construction

Open cage roller bearing (can be re-lubricated)

Rims ..... Axle Mount

1" bore by 2½" hub length

4 inch diameter

Tires: Front and Rear on 11-6644C1010, Front only on 11-6644C1010-A1

Type ..... Tubless

Size ..... 4.10 – 6 NHS

Pressure ..... 55 psi (3.9 bar)

O.D. .... 13" Nominal

Tires: Rear on 11-6644C1010-A1

Size ..... ST175/80D13

Pressure ..... 32 psi (2.2 bar)

6.3 LOCATION AND LAYOUT OF CONTROLS  
6.3.1 Instrumentation and Controls

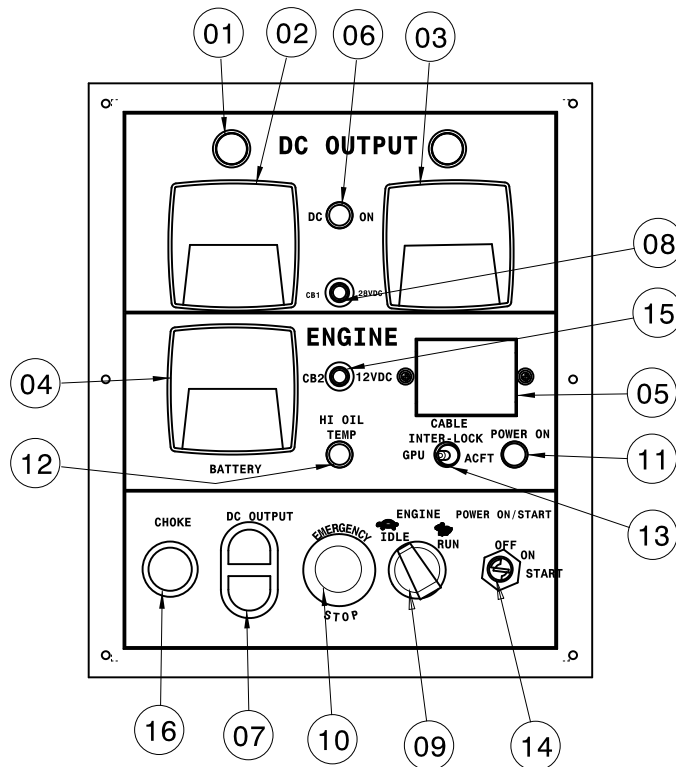

| Item | Description                        |
|------|------------------------------------|
| 1    | Light, Hooded Panel                |
| 2    | Voltmeter, Output 0–50 VDC         |
| 3    | Ammeter, Output 0-3000 amps        |
| 4    | Ammeter, Battery 0-300 amps        |
| 5    | Hourmeter/Tinytach                 |
| 6    | Light, Contactor Energized Control |
| 7    | Switch, DC On/Off                  |
| 8    | Circuit Breaker One 28VDC          |
| 9    | Switch, Idle/Run                   |
| 10   | Switch, Emergency Stop             |
| 11   | Power On Lamp                      |
| 12   | High Oil Temp Lamp                 |
| 13   | Aircraft Cable Inter-Lock Switch   |
| 14   | Power On/Start Switch              |
| 15   | Circuit Breaker Two 12VDC          |
| 16   | Choke Switch                       |

## 6.4 PREPARATION PRIOR TO FIRST USE

### 6.4.1 General

Prior to operating the Ground Power Unit, the user should become familiar with the owner's operating manuals for engine, alternator and batteries found in Appendices II, III and IV.

### 6.4.2 Pre-Start

#### **ALL SWITCHES MUST BE IN THE "OFF" POSITION.**

Complete all the following routine maintenance prior to operating this Ground Power Unit:

- Check engine oil level.
- Check engine fuel level.
- Check and ensure that both the Ground Power Unit engine intake and cooling exit areas are clear and unobstructed.
- Check condition and tension of the alternator drive belts.
- Check battery condition indicators.

### 6.4.3 Oil Recommendations

Using the proper type and weight of oil in the crankcase is extremely important to the life of the unit.

To increase reliability and operational life of this Ground Power Unit:

- Use proper oil type and weight.
- Check oil level daily.
- Change oil per Kohler Operator's Handbook.

#### **Oil Specifications**

To help assist engine running-in, all engines are dispatched with an initial fill lubricating oil which must be changed after 100 hours. All subsequent oil changes must be as specified in Kohler Operator's Handbook.

### 6.4.4 Fuel Recommendations



#### **WARNING! EXPLOSIVE FUEL!**

- **Gasoline is extremely flammable and its vapors can explode if ignited. Store fuel only in approved containers, in well ventilated, unoccupied buildings, and away from sparks or flames.**
- **DO NOT fill the fuel tank while the engine is hot or running. Spilled fuel coming in contact with hot parts or sparks from ignition will ignite.**
- **Do not start the engine near spilled fuel. Never use fuel as a cleaning agent.**
- **Do not add oil to the gasoline**
- **Do not overfill the fuel tank, leave room for the fuel to expand**
- **The user is cautioned that although the engines may operate on fuels outside the above specifications, such operation may well result in excessive wear and damage.**

#### **Fuel Specification**

The engine must only be used with gasoline which conforms to one of the following:

|                               |   |
|-------------------------------|---|
| Fuel Type .....               | For best results use only clean, fresh, unleaded gasoline with a pump sticker octane rating of 87 or higher (In countries using the Research method, it should be 90 octane or higher)          |
| Gasoline/Alcohol Blends ..... | Gasohol (up to 10% ethyl alcohol, 90% unleaded gasoline by volume) is approved as a fuel for Kohler engines. Other gasoline/alcohol blends are not approved                                     |
| Gasoline/Ether Blends.....    | Methyl Tertiary Butyl Ether (MTBE) and unleaded gasoline blends (up to a maximum of 15% MTBE by volume) are approved as a fuel for Kohler engines. Other gasoline/ether blends are not approved |

## 6.5 PERSONAL PROTECTIVE EQUIPMENT

Always wear safety glasses.

## 6.6 CHECKS PRIOR TO START UP

1. Check engine oil level.
2. Check fuel level.
3. Ensure Aircraft power cable switch is at "Off" position.

## 6.7 START UP PROCEDURE

**CAUTION!**

**Ether-based cold start aids must not be used under any circumstances.**

6.7.1 Battery Disconnect Switch  
Move switch to “ON” position

6.7.2 Contactor Power Switch  
This is a two position, center return, push switch. The switch is “OFF” when centered and green indicator light is out.

6.7.3 Throttle Switch  
Ensure Idle/Run switch is down in the “Idle” position

6.7.4 Emergency Stop Switch  
Pushing this switch in will remove electrical power to the engine control box. Twist switch to right to “pop” out and allow power to engine control box.

6.7.5 Engine Key Switch  
Rotate key to the right “ON” position. The following will be observed:

- Green Power On Lamp
- DC Output Voltage Reading

6.7.6 Engine Starter (Start engine)

- Rotating key farther to right to “Start” position will cause engine starter motor to engage.
- DO NOT crank the engine continuously more than 10 seconds at a time.
- ALWAYS allow the starter motor a 60 second cool-down period between cranking attempts if the engine does not start. Failure to follow these guidelines may result in burnout of the starter motor.
- NEVER engage starter when engine is running.

**CAUTION!**

**In the event of “false start”; that is, if the engine attains sufficient speed to disengage the starter but fails to continue running, the engine must be allowed to come to a complete halt before a restart attempt is made.**

**If the flywheel is still rotating when the starter is engaged, then pinion and ring gears may clash.**

6.7.7 Warm Engine at Idle  
If the engine is not allowed to sufficiently warm up prior to acceleration, then engine damage may result. Allow engine to run at low idle for a minimum of 60 seconds.

6.7.8 Throttle to “Run” Position

- Moving the throttle to high position provides full operating power.
- In this position, the following will be observed:
  - Output voltmeter shows full system voltage, approximately 28 volts.

**NOTE: Voltage is dependent on the condition of the batteries. Reference Appendix II: Leece-Neville ‘SC’ Series Alternator Service Manual.**

6.7.9 Check Current to Batteries; 28 Amps or less is Normal.

- Batteries are considered fully charged when the battery ammeter reads 28 amps or less.
- If the amp reading is greater than 28 amps, run the Ground Power Unit at full throttle until the batteries are charged.

6.7.10 Unit Is Now Ready to Provide Electrical Power to Aircraft.

- Pushing contactor switch in energizes the aircraft power cable.
- Follow aircraft manufacturer’s recommendations on plugging aircraft power cable connector into the aircraft receptacle.

**6.8 OPERATING PROCEDURES**

Refer to aircraft manufacturer's instructions.

**WARNING!**

**Do not connect cable to aircraft unless aircraft power cable switch is "Off".**

**6.9 SHUT OFF/SHUTDOWN PROCEDURES****6.9.1 Aircraft Power Cable Switch "Off"**

- Pushing contactor switch in de-energizes the aircraft power cable.
- Follow aircraft manufacturer's recommendations on unplugging the aircraft power cable connector from the aircraft receptacle. If no recommendations are provided, it is suggested that the contactor switch be off (de-energized) prior to removing the connector from the aircraft receptacle.

**6.9.2 Run Unit Until Battery Current Drops to 28 amps or less**

- It is normal, after heavy use, (where more than 150 amps are drawn) that the Ground Power Unit batteries will draw high amperage until recharged.
- Let the Ground Power Unit run at full engine throttle until the batteries are drawing 28 amps or less; it will then be ready for use the next time power is required. Battery recharge time could be over 10 minutes, depending on how much power was used.

**6.9.3 Throttle to Idle**

Reduce engine speed to low position for 30 seconds in order to cool the engine.

**6.9.4 Engine Key Switch to "Off"**

- This opens the 12 volt and 28 volt systems; the voltmeter returns to zero.
- The engine will stop.

**6.10 EMERGENCY SHUTDOWN PROCEDURES**

Push emergency stop in.

**6.11 DESCRIPTION OF ALARM SYSTEMS****6.11.1 High Oil Temperature Lamp**

This light illuminates to indicate high oil temperature in the engine. If this light illuminates, engine will shut off. Service engine to proper oil level.

## 7.0 PACKAGING AND STORAGE

### 7.1 PACKAGING REQUIREMENTS

1. Drain all fuel from tank.
2. Place blocks under axle so that tires are not touching pallet or shipping container.
3. Strap unit to pallet or shipping container at axle and towbar.

**NOTE: Use no less than three (3) straps with minimum 1500 lbs (680 kg) capacity each.**

### 7.2 HANDLING

The unit is designed to be towed by the towbar using suitable towing equipment. The unit can be lifted by means of a fork truck from the side of the machine.

**NOTE: Ensure that forks on fork truck are 48 inches long for stability during lifting.**

### 7.3 PACKAGING PROTECTION

No special packaging material for cushioning or suspension is required.

### 7.4 LABELING OR PACKAGING

Packing should be labeled as follows:

**DO NOT DROP**  
**THIS SIDE UP** ↑

### 7.5 STORAGE COMPATIBILITY

No special considerations for short term storage (less than one month).

### 7.6 STORAGE ENVIRONMENT

- Cover with a suitable, non-abrasive tarp is storing outdoors.
- For storage periods greater than one month, service fuel tank and add fuel stabilizer. Disconnect negative battery cable and cover cable end to prevent contact with ground.
- If storing outdoors in temperatures less than 35o F/2o C for periods greater than one month, remove batteries from unit and store batteries indoors. Do not set batteries directly on concrete floors.

### 7.7 STORAGE SPACE AND HANDLING FACILITIES

Width.....47 in (120 cm)  
Length – 11-6644C1010.....60.5 in (154 cm)  
Length – 11-6644C1010-A1 .....72 in (183 cm)  
Height.....46 in (116 cm)  
Weight.....1,300 lbs (590 kg)

## 8.0 TRANSPORTATION

- Do not stack Ground Power Units.
- The unit can be lifted by means of a fork truck from the side of the machine.

**NOTE: Be sure that forks are long enough to reach across members for stability during lifting.**

- The main handling point is the towbar.
- Weight: 1200 lbs (544 kg)

9.0 TROUBLE SHOOTING

| Problem   | Possible Solution(s)   |
|---|--|
| No indicator lights when key is turned                  | Switch battery to "ON"<br>Ensure emergency stop is in out position<br>Check wiring from battery to starter |
| Indicator light is on, engine starter will not energize | Check for 12 VDC to starter solenoid   |
| Engine starter energized, engine will not run           | Prime fuel system<br><b>Note: Reference Kohler Maintenance Manual for engine trouble shooting</b>          |
| Engine runs, no high throttle                           | Check circuit breaker two<br>Ensure throttle solenoid linkage is not binding                               |
| Engine running, contactor will not energize             | Ensure aircraft power cable is plugged in<br>Ensure engine is running at high throttle                     |

## 10.0 MAINTENANCE

### 10.1 GENERAL

- Periodically inspect Ground Power Unit for loose connections, abrasions to cables and wires, and overall general condition of unit. Make repairs as necessary.
- If the Ground Power Unit will be out of service for two months or more, use the following storage procedure:
  1. Clean the exterior surfaces of the unit, removing dirt and oil residue.
  2. Change the oil and oil filter while the engine is still warm from operation.
  3. The fuel system must be completely emptied, or the fuel must be treated with a stabilizer to prevent deterioration. If you choose to use a stabilizer, follow the manufacturer's recommendations and add the correct amount for the capacity of the fuel system. Fill the fuel tank with clean, fresh fuel. Run the engine for two to three (2-3) minutes to get stabilized fuel into the system.



#### **CAUTION!**

**Never run engine out of fuel.**

**Ensure that all control panel switches are in the "Off" position before making battery disconnections.**



#### **WARNING!**

**Battery posts, terminals and related accessories contain lead and lead compounds; chemicals known to the State of California to cause cancer and reproductive harm.**

**Wash hands after handling batteries and related accessories.**

4. a. Disconnect positive 28 V battery cable labeled "(+) BATTERY LEAD" to location labeled "(+) CONNECTION POINT".
- b. Disconnect negative 28V battery bank cable labeled "(-) BATTERY LEAD" to location labeled "(-) CONNECTION POINT".
- c. Disconnect aircraft power cable at cart.
5. Store the Ground Power Unit in a clean, dry place.

### 10.2 ENGINE

Perform maintenance per schedule outlined in Kohler Operator's Handbook.

The single most important factor in long engine life is maintaining proper oil level and regularly scheduled changing of engine oil.

### 10.3 ALTERNATOR

See Appendix II: Leece-Neville 'SC' Series Alternator Service Manual for specific maintenance and testing regarding the alternator.

### 10.4 BATTERIES

#### **WARNING!**



**Battery posts, terminals and related accessories contain lead and lead compounds; chemicals known to the State of California to cause cancer and reproductive harm.**

**Wash hands after handling batteries and related accessories.**

Refer to the battery bulletin, Appendix III: Delco Battery Bulletin 1B-116, for specific maintenance regarding the batteries.

It is suggested that each year the batteries be individually tested. Replace worn batteries. Acceptable batteries should be fully charged individually.

### 10.5 CHASSIS

Lubricate axle wheel bearings and front hub assembly periodically (minimum once per year) with a multi-purpose lithium wheel bearing grease. Replace seals as required.

Check and maintain tire pressure at 55 psi (3.9 bar).

### 10.6 AIRCRAFT POWER CABLE

Inspect the aircraft power cable periodically for damage, i.e., nicks, cuts, abrasions, etc., that may cause an electrical hazard. Replace damaged cable.



## 11.0 PROVISION OF SPARES

### 11.1 SOURCE OF SPARE PARTS

Spare parts may be obtained from the manufacturer:

**TRONAIR, Inc.**

1 Air Cargo Pkwy East  
Swanton, Ohio 43558 USA

Telephone: (419) 866-6301 or 800-426-6301

Fax: (419) 867-0634

E-mail: sales@tronair.com

Website: www.tronair.com

For Spare Parts, Operations & Service Manuals or Service Needs:  
Scan the QR code or visit Tronair.com/aftermarket



### 11.2 RECOMMENDED SPARE PARTS LISTS

Reference the following page(s) for Replacement Parts and Kits available.

| Part Number | Description        | Qty |
|-------------|--------------------|-----|
| H-1401-09   | BELT, V            | 1   |
| H-3501      | FILTER, OIL        | 1   |
| H-3502      | FILTER, FUEL       | 1   |
| H-2232      | PLUG, KOHLER SPARK | 2   |
| H-3504      | KIT, AIR FILTER    | 1   |

## 12.0 IN-SERVICE SUPPORT

Contact Tronair, Inc. for technical services and information. See Section 1.3 – Manufacturer.

## 13.0 GUARANTEES/LIMITATION OF LIABILITY

Tronair products are warranted to be free of manufacturing or material defects for a period of one year after shipment to the original customer. This is solely limited to the repair or replacement of defective components. This warranty does not cover the following items:

- a) Parts required for normal maintenance
- b) Parts covered by a component manufacturers warranty
- c) Replacement parts have a 90-day warranty from date of shipment

If you have a problem that may require service, contact Tronair immediately. Do not attempt to repair or disassemble a product without first contacting Tronair, any action may affect warranty coverage. When you contact Tronair be prepared to provide the following information:

- a) Product Model Number
- b) Product Serial Number
- c) Description of the problem

If warranty coverage is approved, either replacement parts will be sent or the product will have to be returned to Tronair for repairs. If the product is to be returned, a Return Material Authorization (RMA) number will be issued for reference purposes on any shipping documents. Failure to obtain a RMA in advance of returning an item will result in a service fee. A decision on the extent of warranty coverage on returned products is reserved pending inspection at Tronair. Any shipments to Tronair must be shipped freight prepaid. Freight costs on shipments to customers will be paid by Tronair on any warranty claims only. Any unauthorized modification of the Tronair products or use of the Tronair products in violation of cautions and warnings in any manual (including updates) or safety bulletins published or delivered by Tronair will immediately void any warranty, express or implied.

The obligations of Tronair expressly stated herein are in lieu of all other warranties or conditions expressed or implied. **Any unauthorized modification of the Tronair products or use of the Tronair products in violations of cautions and warnings in any manual (including updates) or safety bulletins published or delivered by Tronair will immediately void any warranty, express or implied and Tronair disclaims any and all liability for injury (WITHOUT LIMITATION and including DEATH), loss or damage arising from or relating to such misuse.**

## 14.0 APPENDICES

APPENDIX I Wiring Diagram – INS-1836

APPENDIX II Declaration of Conformity

APPENDIX III Leece-Neville 'SC' Series Alternator Service Manual

APPENDIX IV Delco Battery Bulletin 1B-116, Delphi Battery Information & Delphi MSDS

Additional Documentation: Kohler Engine Manual

## Parts List

**\*\*When ordering replacement parts/kits, please specify model, serial number and color of your unit.\*\***

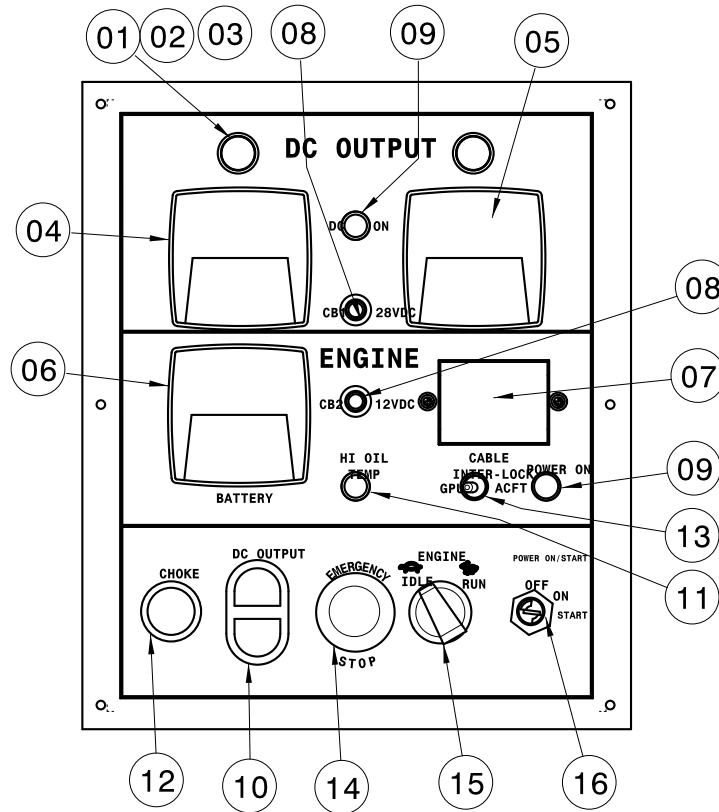

| Item | Part Number | Description                 | Qty |
|------|-------------|-----------------------------|-----|
| 1    | EC-1776     | INDICATOR, SHIELD           | 2   |
| 2    | EC-1767     | INDICATOR BASE, PANEL MOUNT | 2   |
| 3    | EC-1768     | LAMP, INCANDESCENT 24 VDC   | 3   |
| 4    | EC-3327     | VOLTMETER, DC (0-50)        | 1   |
| 5    | EC-1343     | AMMETER, DC (0-2000)        | 1   |
| 6    | EC-1341     | AMMETER, DC (0-300)         | 1   |
| 7    | 19027TT     | HOURMETER/TINYTACH          | 1   |
| 8    | 12001       | CITCUIT BREAKER 10A         | 2   |
| 9    | 14128       | LAMP ASSEMBLY (GREEN)       | 2   |
| 10   | 14131       | DC ON/OFF                   | 1   |
| 11   | 14126       | LAMP ASSEMBLY (RED)         | 1   |
| 12   | 14141       | SWITCH, CHOKE               | 1   |
| 13   | 12009       | SWITCH, TOGGLE              | 1   |
| 14   | 14132       | SWITCH, EMERGENCY STOP      | 1   |
| 15   | 14133       | SWITCH, IDLE/RUN            | 1   |
| 16   | 25-099-04-5 | SWITCH, KEY START           | 1   |

## Parts List

**\*\*When ordering replacement parts/kits, please specify model, serial number and color of your unit.\*\***

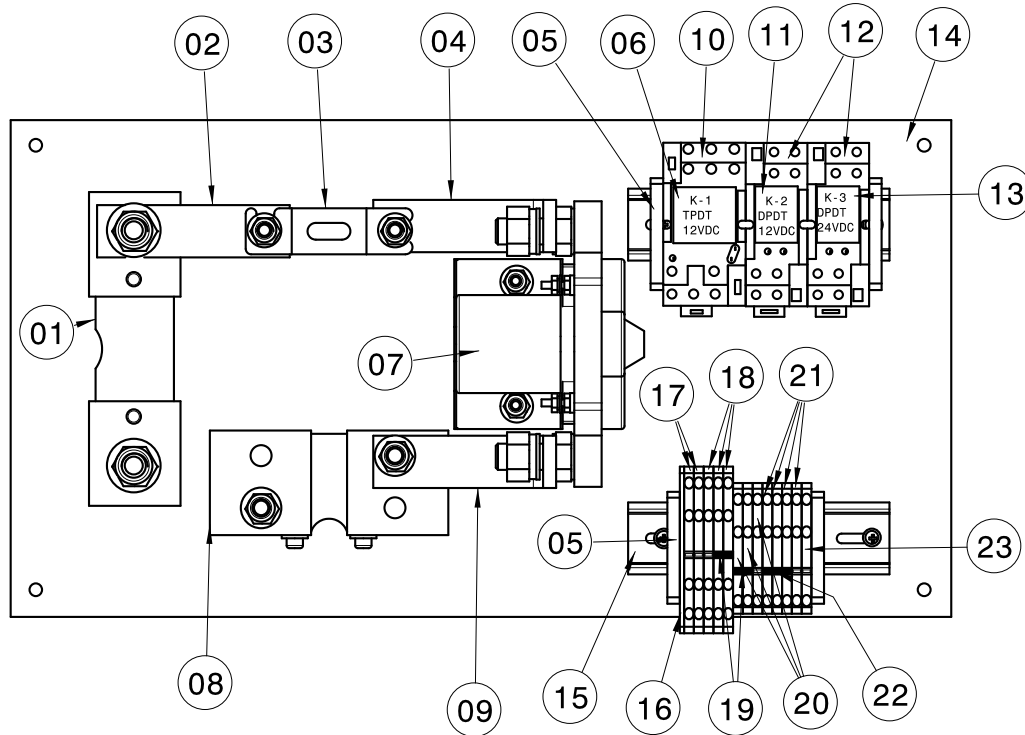

| Item | Part Number  | Description                        | Qty |
|------|--------------|------------------------------------|-----|
| 1    | EC-1029      | SHUNT, 50MV, 300A                  | 1   |
| 2    | J-3702       | BUSSBAR, INPUT                     | 1   |
| 3    | EC-1624-24   | FUSE, VERY FAST ACTING             | 1   |
| 4    | J-3703       | BUSSBAR, INTERMEDIATE              | 1   |
| 5    | 13070        | ANCHOR, DIN RAIL                   | 4   |
| 6    | EC-1968      | RELAY, COMPACT SPADE (TPDT) 12VAC  | 1   |
| 7    | EC-1027      | CONTACT, OUTPUT                    | 1   |
| 8    | 13002        | SHUNT, 2500A                       | 1   |
| 9    | J-3704       | BUSSBAR, OUTPUT                    | 1   |
| 10   | 13074        | SOCKET, RELAY (11 PIN)             | 1   |
| 11   | EC-1955      | RELAY, CONTACT SPADE (DPDT)        | 1   |
| 12   | 13073        | SOCKET, RELAY (8 PIN)              | 2   |
| 13   | 13063        | RELAY, CONTACT SPADE (DPDT) 24 VAC | 1   |
| 14   | J-3840       | PANEL, ELECTRICAL                  | 1   |
| 15   | 13072#005.00 | RAIL, DIN                          | 2   |
| 16   | 13075        | BARRIER, END (4 POLE)              | 1   |
| 17   | 13069        | BLOCK, TERMINAL YELLOW 4-WAY       | 2   |
| 18   | 13068        | BLOCK, TERMINAL BLACK 4-WAY        | 3   |
| 19   | 13060        | JUMPER, 2 PRONG                    | 2   |
| 20   | 13089        | BLOCK, TERMINAL GRAY 4-WAY         | 3   |
| 21   | 13067        | BLOCK, TERMINAL GREEN 3-WAY        | 4   |
| 22   | 13061        | JUMPER, 3 PRONG                    | 1   |
| 23   | 13066        | BLOCK, TERMINAL WHITE 3-WAY        | 1   |

## Parts List

**\*\*When ordering replacement parts/kits, please specify model, serial number and color of your unit.\*\***

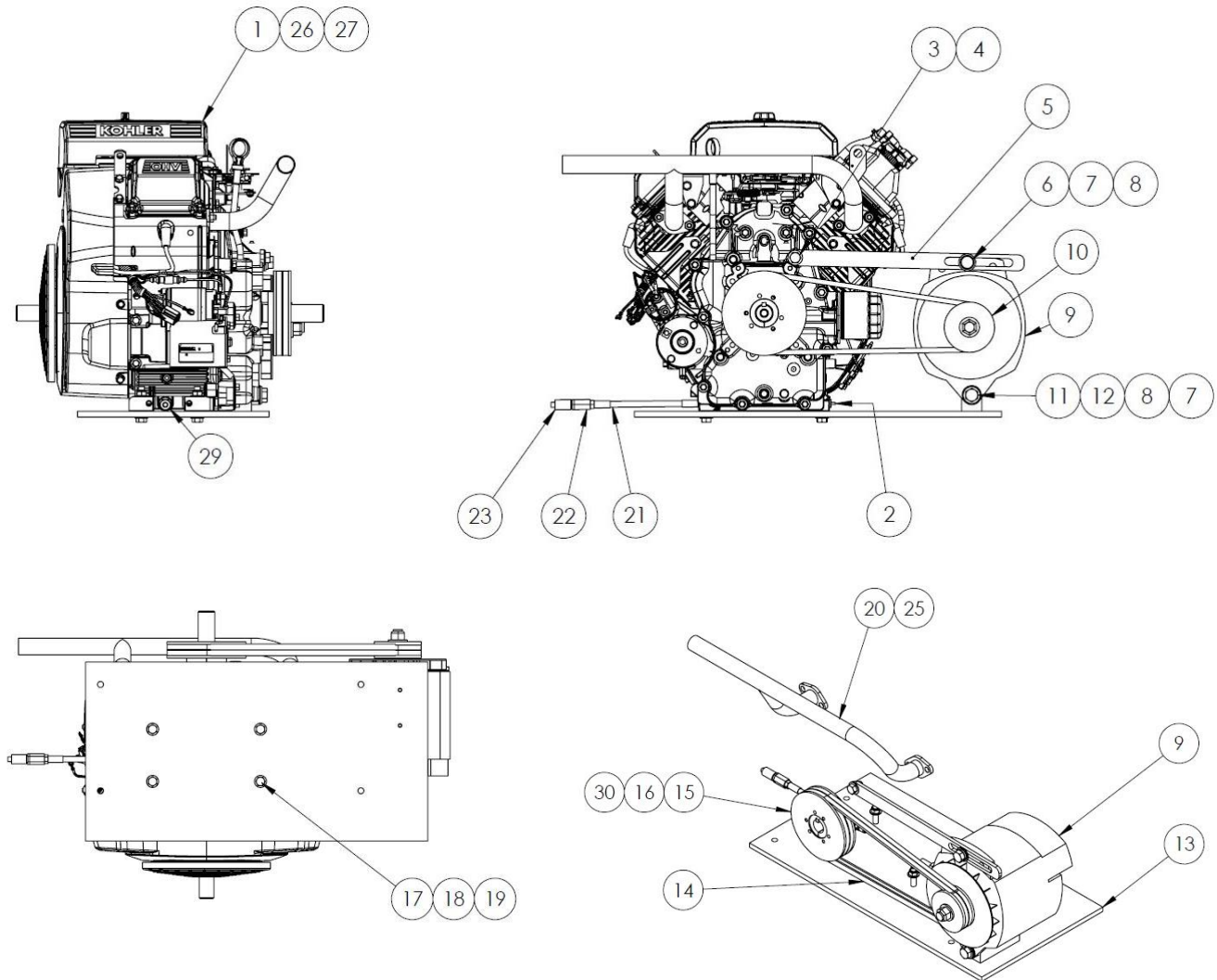

### Parts List

**\*\*When ordering replacement parts/kits, please specify model, serial number and color of your unit.\*\***

| Item | Part Number    | Description                        | Qty |
|------|----------------|------------------------------------|-----|
| 1    | H-4257         | ENGINE, KOHLER CH620-3157 COMPLETE | 1   |
| 2    | 19027OS        | SENSOR, OIL TEMPERATURE            | 1   |
| 3    | G-1100-108006  | BOLT, 7/16-14 X 3/4" HEX HD GR 5   | 1   |
| 4    | G-1250-1080N   | FLATWASHER, 7/16 NARROW            | 1   |
| 5    | J-3830-00      | BRACKET, ALTERNATOR ADJUSTING      | 1   |
| 6    | G-1100-109010  | BOLT, 1/2-13 X 1.0" HEX HD GR 5    | 1   |
| 7    | G-1251-1090R   | LOCKWASHER, 1/2 REGULAR            | 2   |
| 8    | G-1250-1090N   | FLATWASHER, 1/2 NARROW             | 3   |
| 9    | EC-1123        | ALTERNATOR, 24 VDC                 | 1   |
| 10   | H-1405         | SHEAV, ALTERNATOR                  | 1   |
| 11   | G-1100-109564  | BOLT, 1/2-20 X 6-1/2" HEX HD GR 5  | 1   |
| 12   | G-1202-1095    | STOPNUT, 1/2-20 ELASTIC            | 1   |
| 13   | Z-6247-00      | WELDMENT, ENGINE MOUNT (P)         | 1   |
| 14   | H-1401-09      | BELT, V                            | 2   |
| 15   | H-1057-5.30    | SHEAVE, 2 GROOVE                   | 1   |
| 16   | H-1060-1.125   | BUSHING, SHEAVE (SH)               | 1   |
| 17   | G-1420-107020  | BOLT, 3/8-16 X 2.0" HEX HD GR 8    | 4   |
| 18   | G-1202-1070    | STOPNUT, 3/8-16 ELASTIC            | 4   |
| 19   | G-1250-1070N   | FLATWASHER, 3/8 NARROW             | 8   |
| 20   | H-5013         | MANIFOLD, EXHAUST                  | 1   |
| 21   | 24-326-56-S    | HOSE, OIL DRAIN                    | 1   |
| 22   | 25-249-01-S    | COUPLING, 3/8 FEMALE               | 1   |
| 23   | 25-755-14-S    | VALVE, OIL DRAIN                   | 1   |
| 24   | INS-1860       | ENGINE HARNESS WIRE MAKEUP CHART   | 1   |
| 25   | 24-041-49-S    | MANIFOLD GASKET                    | 2   |
| 26   | 24-755-101-S   | KIT, THROTTLE/CHOKE                | 1   |
| 27   | 25-176-02-S    | WIRING HARNESS                     | 1   |
| 29   | N-2800-05-S    | FITTING, MALE PIPE                 | 1   |
| 30   | J211-01-001.50 | KEY, 1/4" SQUARE X 1 1/2" LONG     | 1   |

**Parts List**

**\*\*When ordering replacement parts/kits, please specify model, serial number and color of your unit.\*\***

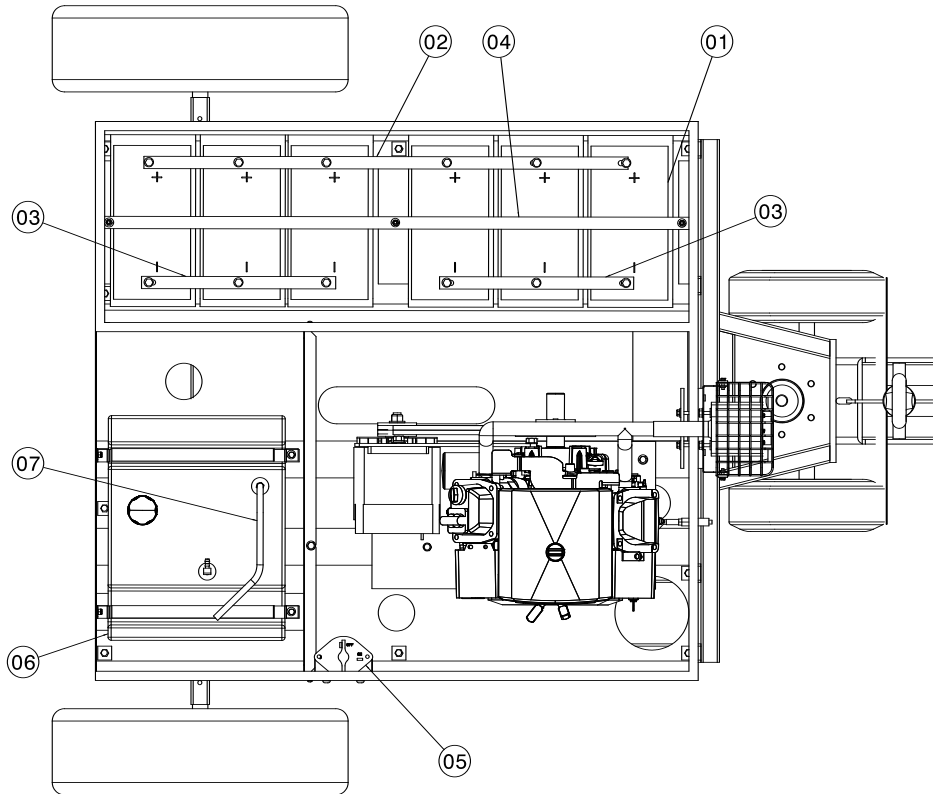

| Item | Part Number     | Description                 | Qty |
|------|-----------------|-----------------------------|-----|
| 1    | EC-1656         | BATTERY, 12 V               | 6   |
| 2    | J-3711          | BAR, CONNECTOR              | 1   |
| 3    | J-1177          | BAR, CONNECTOR              | 2   |
| 4    | J-3700-01       | HOLD DOWN, BATTERY          | 1   |
| 5    | EC-2700         | SWITCH, BATTERY DISCONNECT  | 1   |
| 6    | H-3823          | TANK, FUEL                  | 1   |
| 7    | TF-1243-04-61.0 | HOSE, LOW PERMEABILITY FUEL | 1   |
| N/S  | H-3351          | CAP, GAGE FUEL              | 1   |

## Parts List – 11-6644C1010

**\*\*When ordering replacement parts/kits, please specify model, serial number and color of your unit.\*\***

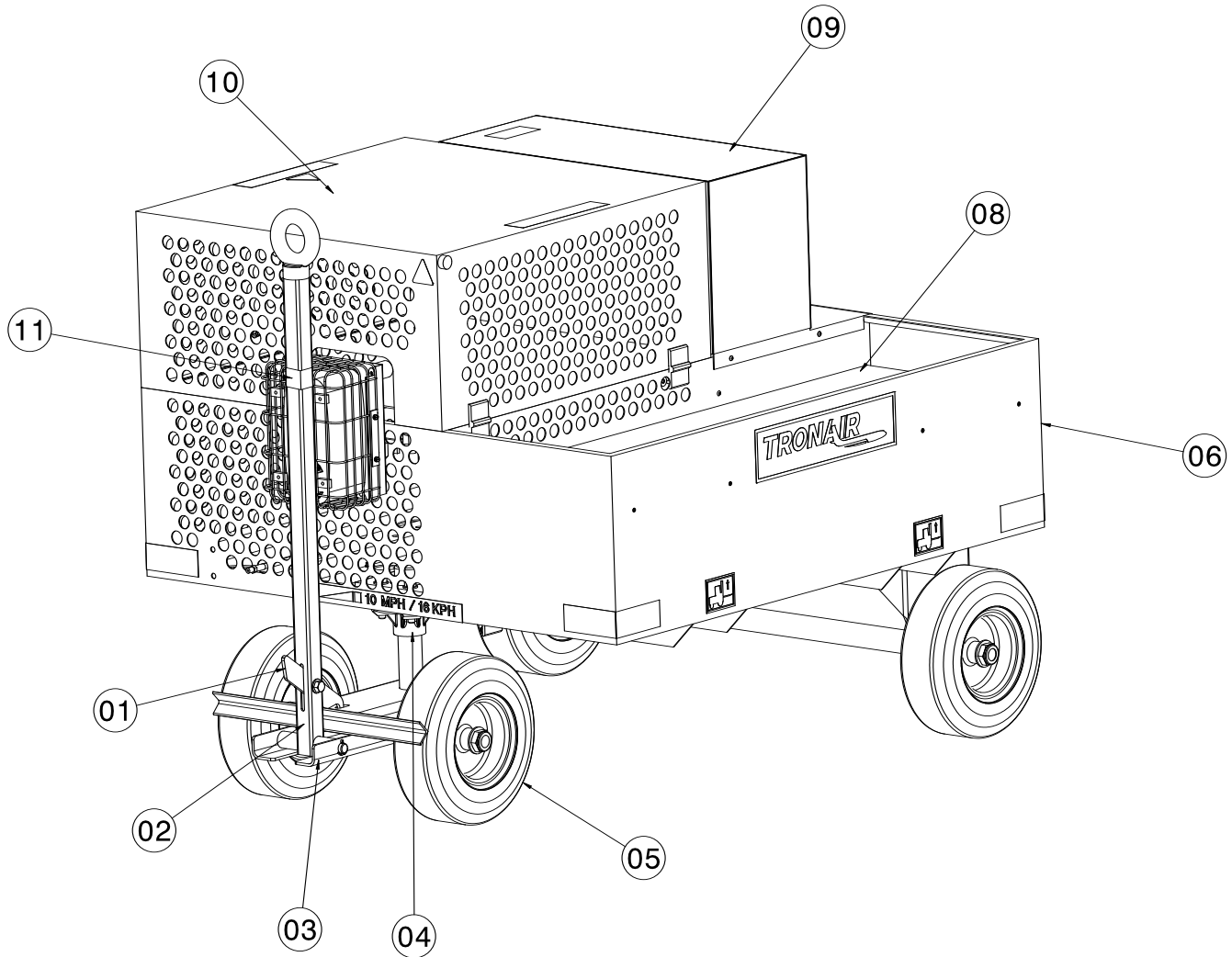

| Item | Part Number   | Description               | Qty |
|------|---------------|---------------------------|-----|
| 1    | J-3427        | LEVER                     | 1   |
| 2    | Z-7023-01     | WELDMENT, TOWBAR          | 1   |
| 3    | Z-6072-01     | WELDMENT, STEER AXLE      | 1   |
| 4    | H-2789        | HUB, IDLER                | 1   |
| 5    | U-1144        | ASSEMBLY, TIRE/RIM        | 4   |
| 6    | Z-6071-01     | WELDMENT, FRAME           | 1   |
| 8    | J-3836        | TRAY, BATTERY COMPARTMENT | 1   |
| 9    | S-2767-01     | COVER, PANEL EPA          | 1   |
| 10   | S-2085-00     | COVER, ENGINE             | 1   |
| 11   | H-2806*006.00 | REFLECTOR, YELLOW         | 1   |
| N/S  | EC-1927-20    | ASSEMBLY, A/C CABLE       | 1   |

## Parts List – 11-6644C1010-A1

**\*\*When ordering replacement parts/kits, please specify model, serial number and color of your unit.\*\***

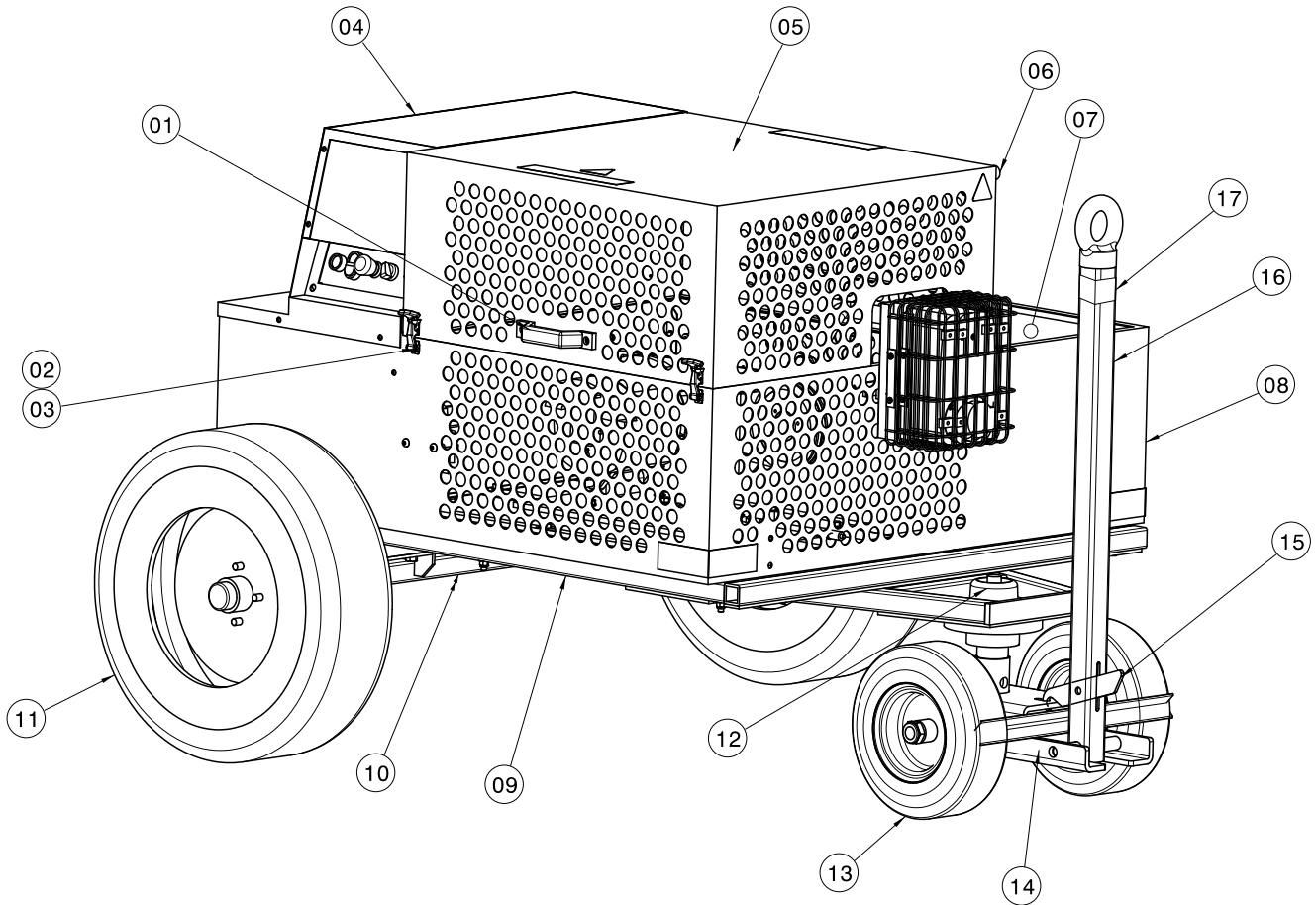

| Item | Part Number    | Description               | Qty |
|------|----------------|---------------------------|-----|
| 1    | H-1780         | HANDLE                    | 1   |
| 2    | 12019-1        | LATCH, FLEXIBLE           | 1   |
| 3    | 12019-2        | CATCH PLATE               | 1   |
| 4    | S-2767-01      | COVER, PANEL EPA          | 1   |
| 5    | S-2468-01      | COVER, ENGINE             | 1   |
| 6    | 12029          | BUMPON                    | 1   |
| 7    | J-3836         | TRAY, BATTERY COMPARTMENT | 1   |
| 8    | Z-7589-01      | WELDMENT, FRAME BODY      | 1   |
| 9    | K-4521         | KIT, TRAILER CONVERSION   | 1   |
| 10   | Z-7561-01      | WELDMENT, AXLE            | 1   |
| 11   | U-1148         | WHEEL, REAR               | 2   |
| 12   | H-3200         | HUB                       | 1   |
| 13   | U-1144         | ASSEMBLY, TIRE/RIM        | 2   |
| 14   | Z-7567-01      | WELDMENT, STEER AXLE      | 1   |
| 15   | J-3427         | LEVER                     | 1   |
| 16   | Z-6003-01      | WELDMENT, TOWBAR          | 1   |
| 17   | H-2806-*006.00 | REFLECTOR, YELLOW         | 1   |



**Parts List**

**\*\*When ordering replacement parts/kits, please specify model, serial number and color of your unit.\*\***

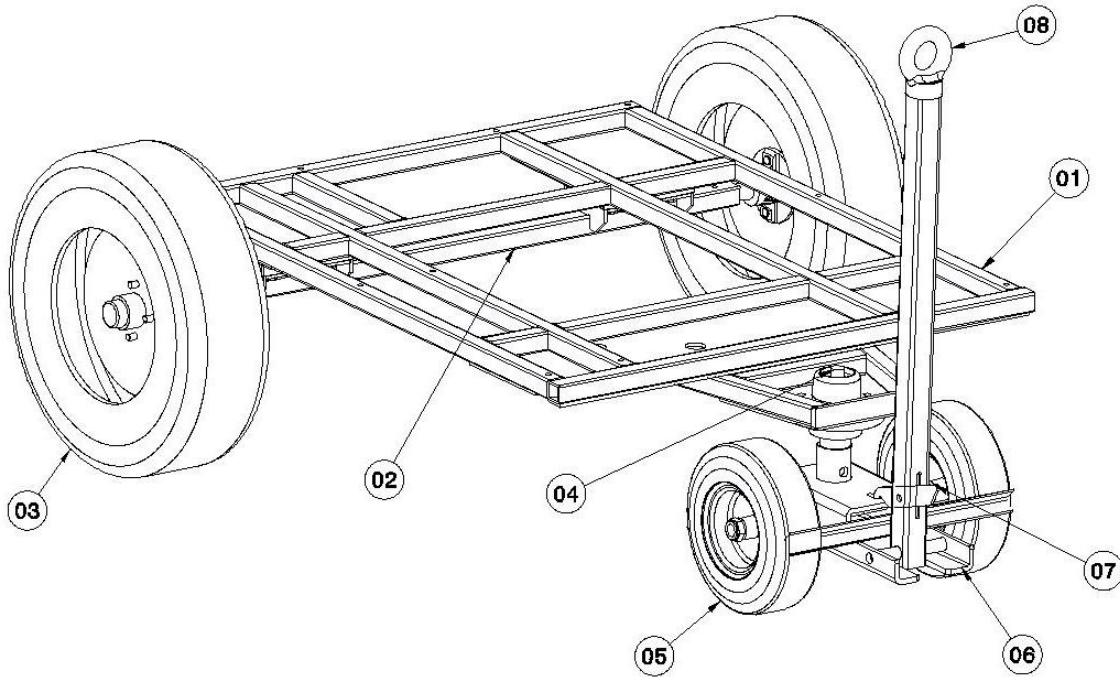

| Item | Part Number | Description   | Qty |
|------|-------------|---|-----|
| 1    | K-4521      | <b>KIT, TRAILER CONVERSION;</b> <i>consists of:</i> | 1   |
| 2    | Z-7561-01   | WELDMENT, AXLE                                      | 1   |
| 3    | U-1148      | WHEEL, REAR   | 2   |
| 4    | H-3200      | HUB   | 1   |
| 5    | U-1113      | ASSEMBLY, TIRE/RIM                                  | 2   |
| 6    | Z-7567-01   | WELDMENT, STEER AXLE                                | 1   |
| 7    | J-3427      | LEVER   | 1   |
| 8    | Z-6003-01   | WELDMENT, TOWBAR                                    | 1   |





## **APPENDIX I**

### **Wiring Diagram**





## **APPENDIX II**

### **Declaration of Conformity**





# EU Declaration of Conformity

**Model Number(s)** 11-6644C1010, 11-6644C1010-A1  
**Product Type/Name:** Gasoline Powered Ground Power Unit  
**Serial Number(s):** Enter serial number(s)

**Declaration:** Tronair has assessed the equipment described above against the Essential Health and Safety Requirements of one or more Directives. Based on this assessment, the equipment described above is deemed to comply with the directive(s) listed below.

This declaration of conformity is issued under the sole responsibility of the manufacturer.

**Directives:** European Machinery Directive 2006/42/EC  
Electromagnetic Compatibility 89/336/EEC

**Standards:** EN 1915-1 2013 Aircraft ground support equipment – General requirements – Part 1: Basic safety requirements

**Markings:** 

**The technical documentation for the machinery is available from:**

Mr. Joel Nunn  
34 Epirus Road, SW6 7UH, London, UK  
Email: [jnunn@tronair.com](mailto:jnunn@tronair.com)

**Location of Issue:** Tronair, 1 Air Cargo Parkway East, Swanton, OH 43558

**Certificate:** EU\_DoC\_11-6644C1010, 11-6644C1010-A1

**Identification of person empowered to sign on behalf of the Manufacturer:**

  
Quality Assurance Representative

Enter a date  
Date









## **APPENDIX III**

### **Leece-Neville 'SC' Series Alternator Service Manual**





SERVICE MANUAL FOR THE  
85C / 5CJ  
SERIES ALTERNATOR

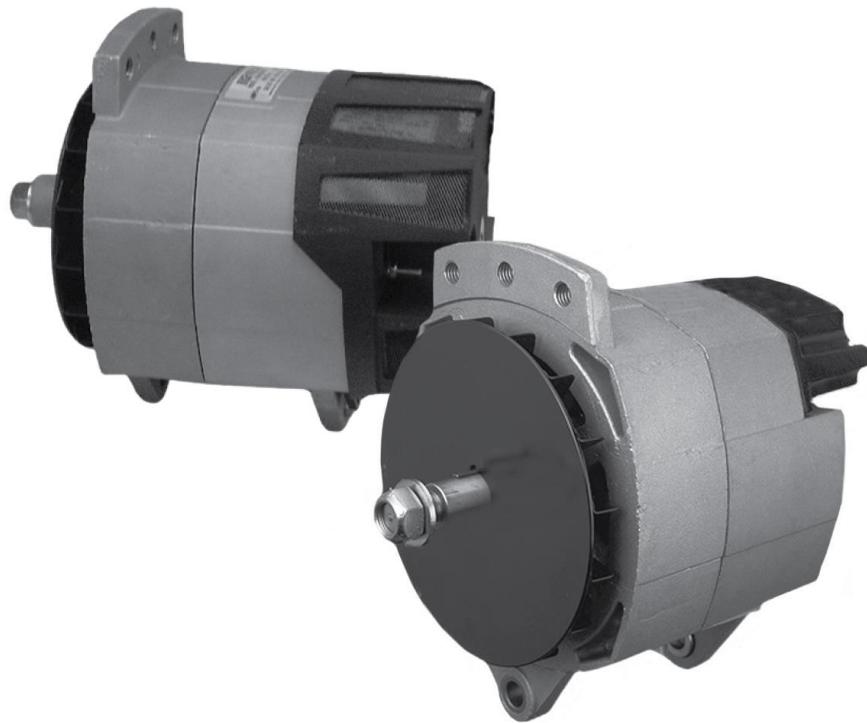

BASIC SYSTEM TROUBLESHOOTING  
AND REPAIR

TSM1002 4/11



7585 Empire Drive | Florence, KY 41042 | (800) 354-0560 | [www.prestolite.com](http://www.prestolite.com)

## Table of Contents

|  |    |
|--|----|
| <b>Causes of Charging System Failure</b>   | 3  |
| <b>Alternator Disassembly</b>              | 4  |
| Front Bearing Change                       | 6  |
| Slip Ring / Rear Bearing Inner Race Change | 10 |
| Rear Bearing Change                        | 13 |
| Installing Rotor Into Front Housing        | 15 |
| <b>Alternator Assembly Instructions</b>    | 16 |

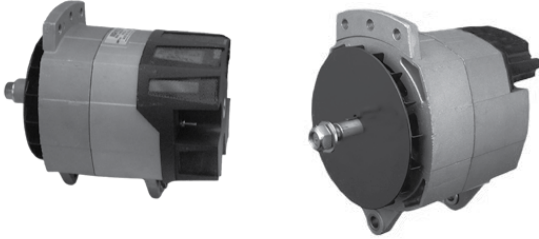

**Description:**

The 8SC/SCJ series alternators are air cooled, belt driven units designed for heavy duty diesel engine applications.

These units feature an integral voltage regulators, fully enclosed brushes, built-in rectifier assemblies with solid lead frame and extra large heat sinks, a dynamically balanced rotor, and heavy duty stator and bearings. The 8SC/SCJ series comes in a vast array of features which includes, remote sense, self excite, ignition excite, lamp and Multipower Technology™.

**Mode of operation:**

The vehicle battery supplies excitation to the field coil (rotor coil) through the regulator and brushes, to create a magnetic field around the rotor and through the stator.

When the rotor is set in motion, the moving magnetic field induces an alternating current (AC) in the stator windings. This output current increases with the speed of the rotor.

The (AC) produced in the stator is converted to direct current (DC) by the positive and negative rectifier assemblies. The rectifier assemblies are connected to the alternator output terminals to provide (DC) output for charging the batteries and to satisfy the vehicle electrical loads.

The regulator monitors the output voltage through sensing leads which are connected to the positive and negative rectifier assemblies, or on some models this is done externally through a remote sense (S) terminal. When the output voltage deviates from the set voltage, the regulator takes corrective action to maintain the output voltage at the proper level. For more detailed information on how an alternator works please see our training CD PP-1216.

**Causes of Charging System Failure:**

Charging system malfunction is identified by the battery

1. OVERCHARGED BATTERIES caused by one or a combination of the following:
  - A. Defective Battery.
  - B. Defective regulator.
  - C. Poor sensing lead contact to regulator or rectifier assembly.
  
2. UNDERCHARGED BATTERIES caused by one or a combination of the following:
  - A. Loose belts; corroded, broken, loose or dirty terminals; broken wiring; undersize wiring; defective batteries.
  - B. Alternator field circuit malfunction caused by one or a combination of the following:
    - a. Poor contacts between regulator and brushes.
    - b. No residual magnetism in rotor.
    - c. Defective regulator.
    - d. Damaged or worn brushes.
    - e. Damaged or worn slip rings.
    - f. Poor connection between slip ring assembly and field coil leads.
    - g. Rotor coil shorted, open, or grounded.
  - C. Alternator generating section malfunction caused by one of the following:
    - a. Stator phase(s) shorted, open, or grounded.
    - b. Rectifier assembly grounded.
    - c. Rectifier(s) shorted or open.

**On- Vehicle or Test Stand Troubleshooting:**

Detailed information can be found on our web site at [www.prestolite.com](http://www.prestolite.com).

When on our web site, look up the alternator model you have questions on and you will find hyperlinks that will take you to information pertaining to that model. You can also contact our technical support hot line at 1-866-288-9853.

Good information to reference would be our training manual PP-1127 or our training CD PP-1216.

# Alternator Disassembly

Step 1: Remove trash screen from alternator if equipped. (Fig 1)

Step 2: Remove regulator by removing 4 screws and unplug connector. (Fig 2)

Step 3: Remove brush holder cover, brush wires and brush holder. (Fig 3 and 4)

Step 4: Flip unit over and remove the pulley nut, fan and four thru bolts. (5 and 6)

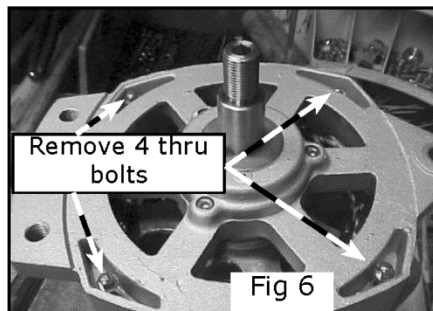
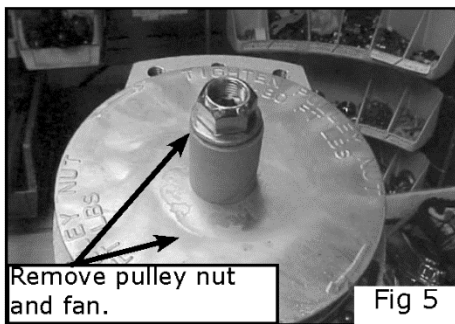
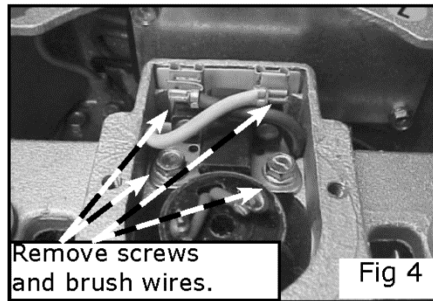
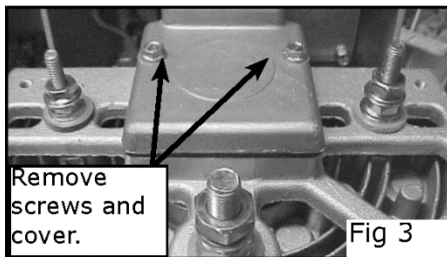
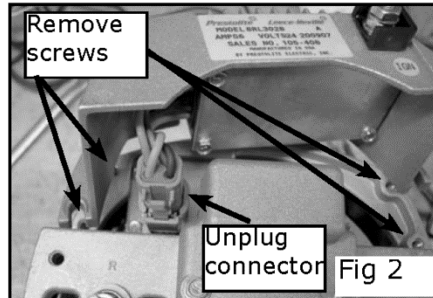
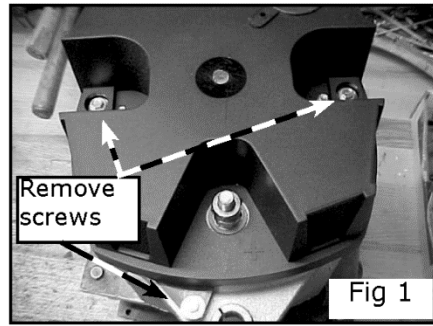

Step 5: Lift front housing splitting alternator. (Fig 6)

Step 6: Remove three stator nuts then remove stator from rear housing (Fig 7)

Step 7: On certain models unsolder leads from rectifier. (Fig 8)

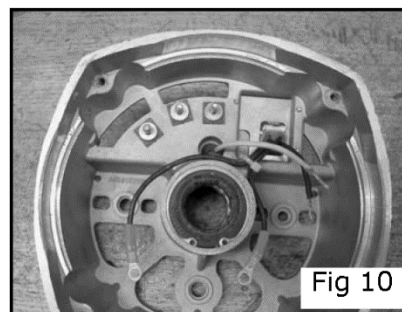
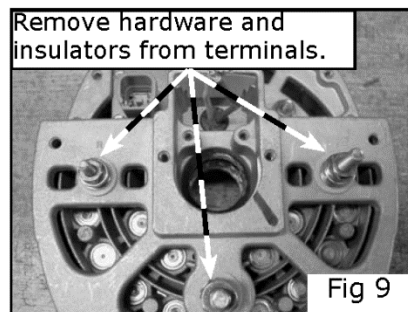
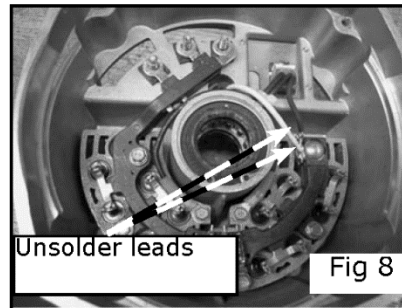
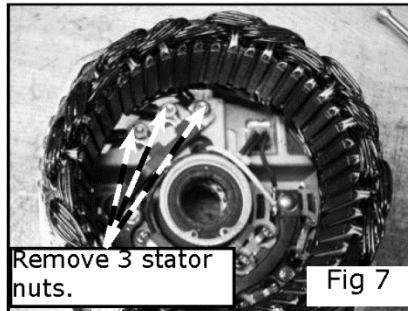
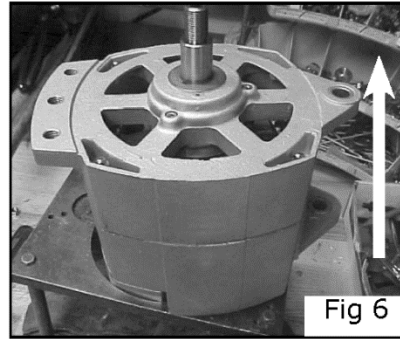

Step 8: Flip the rear housing over and remove all hardware and insulators from the three terminals. (Fig 9)

Step 9: Remove rectifier from rear housing (Fig 10)

## Front bearing change:

Step 1: Remove steel washer and felt seal from shaft. (Fig 1)

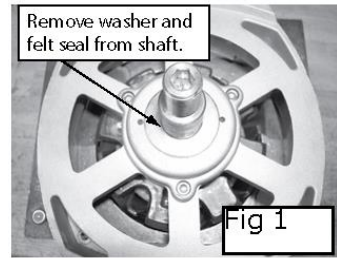

Step 2: Press rotor from front housing. (Fig 2)

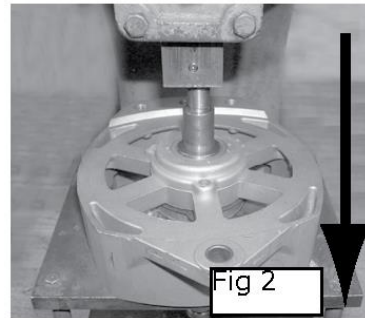

Step 3: Remove spacer and three front bearing retaining screws. (Fig 3)

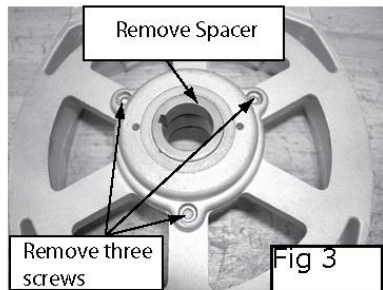

Step 4: Press front bearing and seals from front housing. (Fig 4)

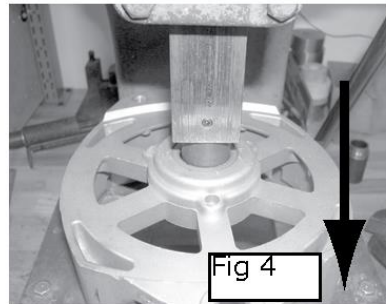



Step 5: Remove seal from front housing.  
(Fig 5)

Step 6: Remove seal from front bearing  
retainer. (Fig 6)

Note: On opposite sides of the front housing  
and bearing retainer are two holes. Insert a  
punch into these holes and tap with a ham-  
mer to remove the seals.

Step 7: Insert front housing seal. (Fig 7)

Step 8: Insert front bearing retainer seal.  
(Fig 8)

Note: When installing seals, press on the  
outer diameter. Failure to do this can cause  
damage to the seals.

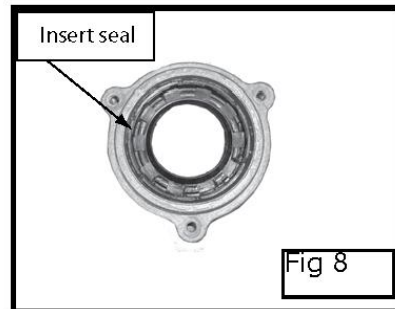
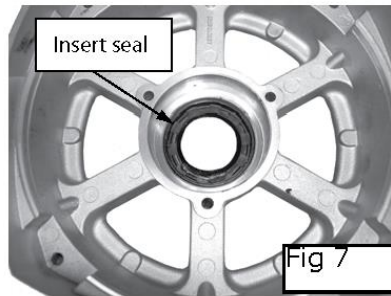
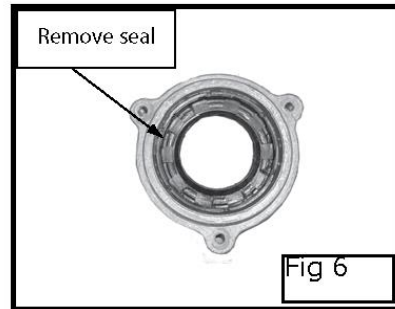
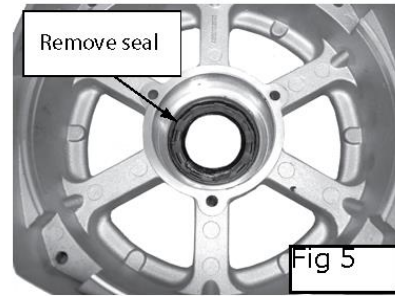

Step 9: Press bearing into front housing. (Fig 9)

Note: When installing bearings, press on the outer diameter. Failure to do this can cause damage to the bearing.

Step 10: Install front bearing retainer. (Fig 10)

Step 11: While holding front bearing retainer in place, turn over housing. Apply blue locktite to three mounting screws and install into front housing. (Fig 11)

Step 12: With a grease needle, inject grease between the seal and the bearing. (Fig 12)

Note: Grease needle can be purchased at any auto parts store.

Recommended grease:

High temperature synthetic bearing grease.

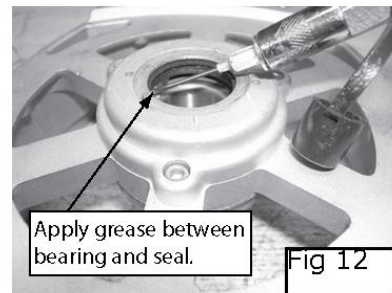
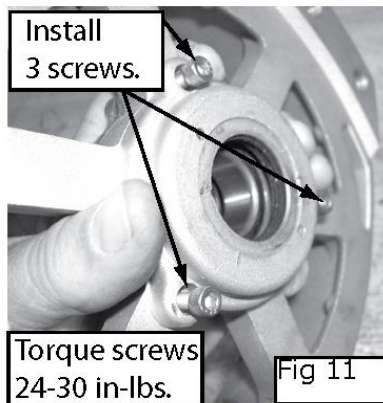
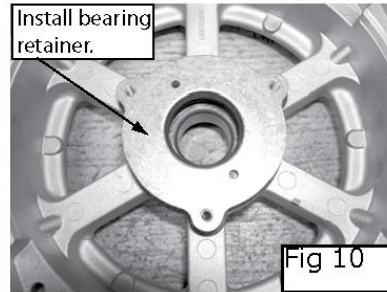
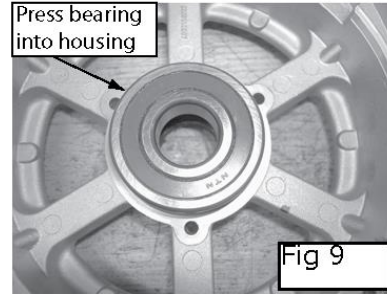

Step 13: Turn housing over and with the grease needle inject grease between the seal and the bearing. (Fig 13)

Step 14: Figure 14 and 15 shows the proper amount of grease that needs to be applied.

Note: The grease added between the bearing and the seals adds an additional protective measure in preventing dust from penetrating the bearing. This grease provides no lubricating properties to the front bearing.

Figure 16 shows you the proper arrangements of components in the front housing.

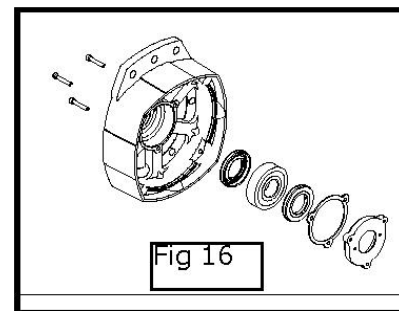
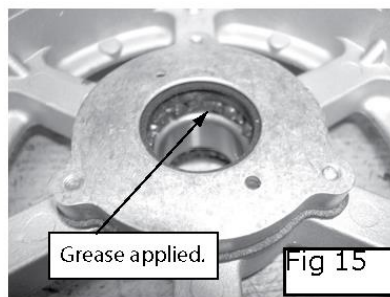
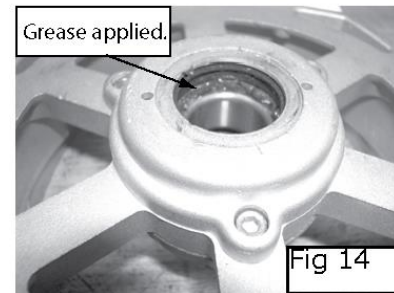
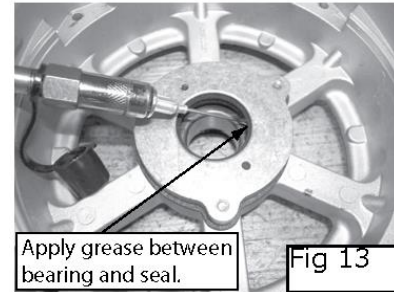

## Slip ring/ rear bearing inner race change:

Inspect rotor and measure key items in Fig 1.

If Dim A or B is out of tolerance a new rotor will need to be purchased. Refer to SP-1017 to determine correct replacement part number.

If Dim C or D is out of tolerance or excessive wear is present then proceed with this procedure.

Note: Use caution not to damage field wires during the following procedures.

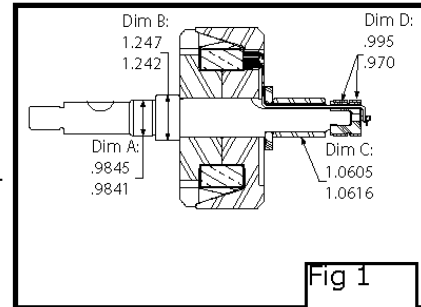

Step 1: Unsolder field wires from slip ring. (Fig 2)

Step 2: Remove slip ring from shaft. (Fig 3)  
Note: Use caution not to damage end of shaft during slip ring removal.

Step 3: Cut nylon spacer off shaft and discard. (Fig 4)

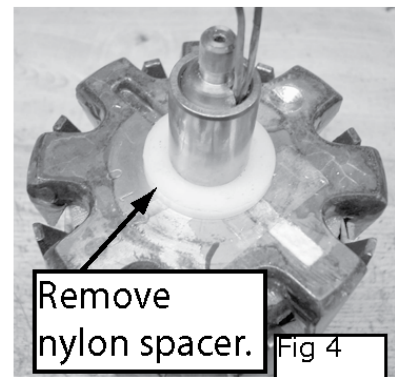
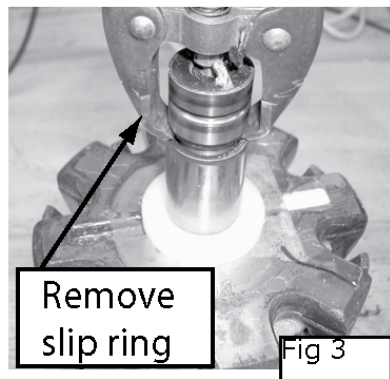
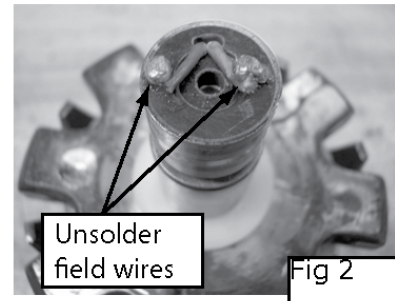

Step 4: Clamp on bearing separator and press bearing inner race off shaft. (Fig 5)

Note: Use caution not to damage shaft or field wires.

Step 5: Apply high temperature silicone sealant on rotor. (Fig 6)

Step 6: Place new nylon spacer on shaft. (Fig 7)

Step 7: Press bearing inner race onto shaft. (Fig 8)

Note: Use caution not to damage field wires during installation.

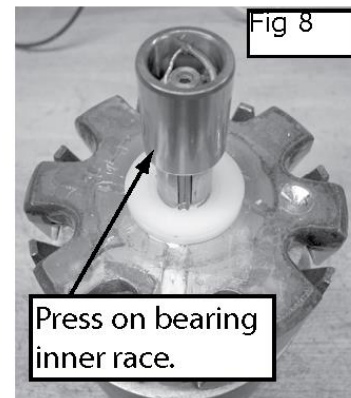
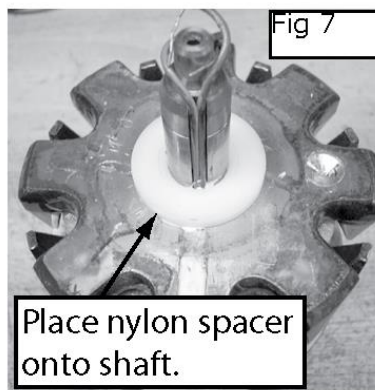
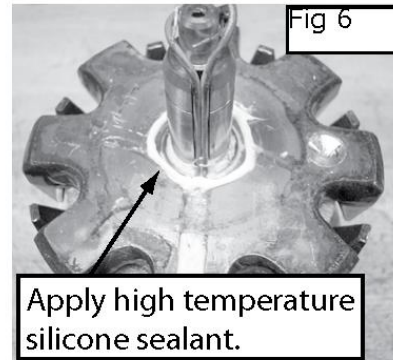
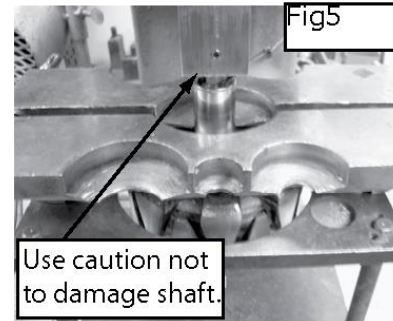

Step 8: Insert field wires through slip ring.  
(Fig 9)

Step 9: Press slip ring onto shaft. (Fig 10)

Note: Use caution not to damage field wires while performing Step 9 and press on slip ring outer diameter to prevent damage.

Step 10: Wrap field wires around slip ring posts and solder. (Fig. 11)

Recommended solder: SN15PB85

Figure 12 shows you the proper arrangements of components in the rotor.

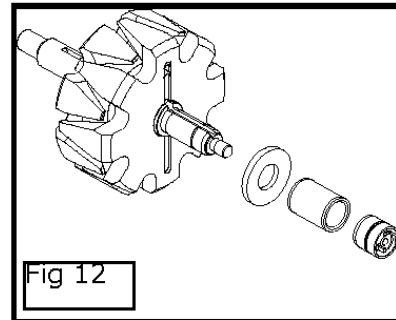
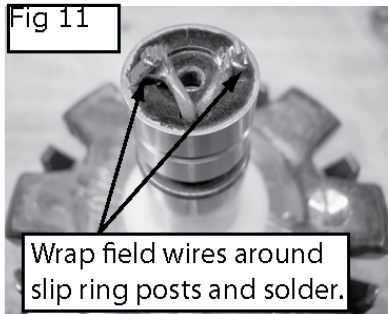
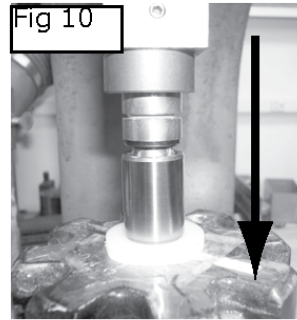
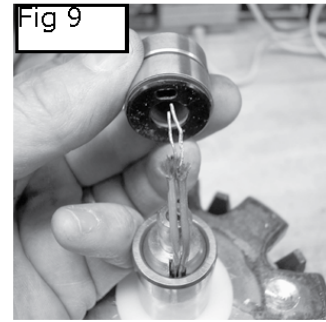

## Rear bearing change:

Step 1: Remove snap ring from rear housing.  
(Fig 1)

Step 2: Press old seals and bearing from rear housing. (Fig 2)

Step 3: Pack new bearing and seal cavities with grease. (Fig 3)

Recommended grease:

High temperature synthetic bearing grease.

Step 4: Press seal into rear housing. (Fig 4)

Note: When installing seals, press on the outer diameter. Failure to do this can cause damage to the seals.  
Use caution not to contaminate grease.

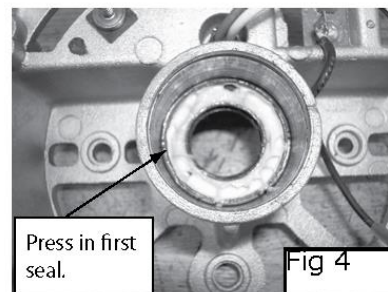
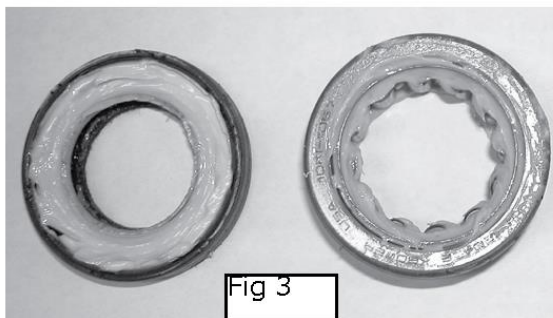
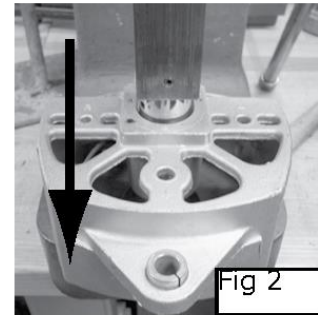
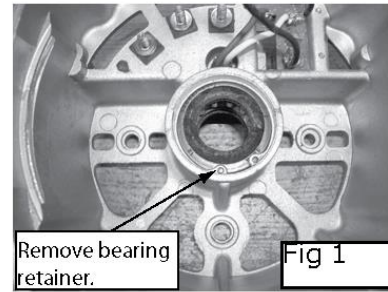

Step 5: Press bearing into rear housing.  
(Fig 5)

Note: When installing bearings, press on the outer diameter. Failure to do this can cause damage to the bearing.

Step 6: Press seal into rear housing. (Fig 6)

Step 7: Install snap ring into rear housing.  
(Fig 7)

Figure 8 shows you the proper arrangements of components in the rear housing.

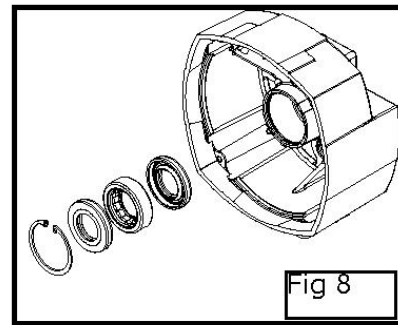
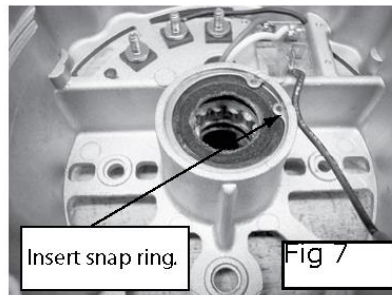
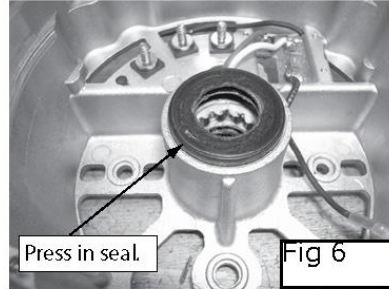
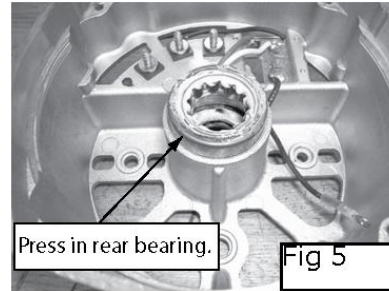



## Installing rotor into front housing:

Step 1: Press rotor into front housing. (Fig 1)

Note: When pressing rotor support front housing as close to the bearing as possible to prevent damage to the front housing.

Use caution not to damage slip ring when pressing rotor into front housing.

Step 2: Slide spacer onto shaft. (Fig 2)

Step 3: Slide felt and steel washer on shaft. (Fig 3)

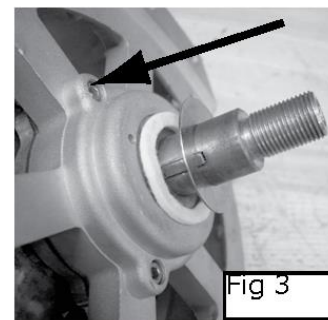
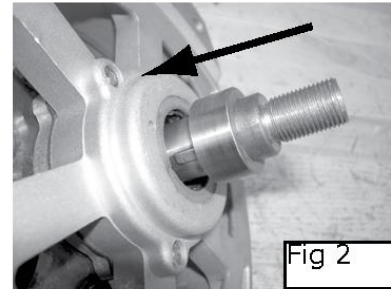
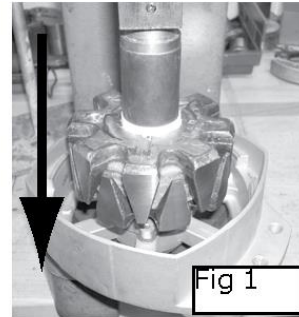

# Alternator Assembly Instructions

## Alternator Assembly

Step 1: If replacing rectifier, remove screw and wire furnished with replacement rectifier. (Fig 1)

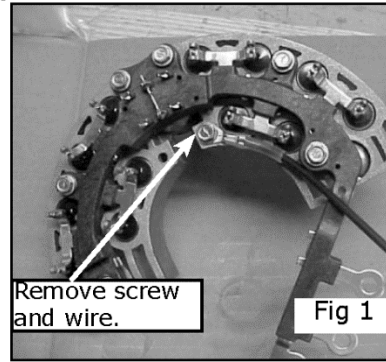

Step 2: Slide #10 carriage bolt into replacement rectifier and insert black insulating sleeve over the bolt. (Fig 2)

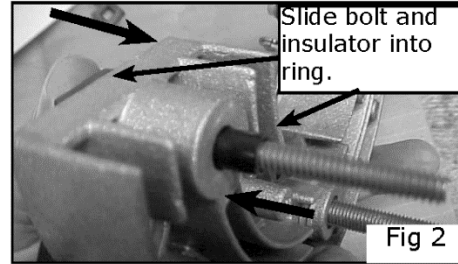

Step 3: Insert insulators into rear housing. (Fig 3)

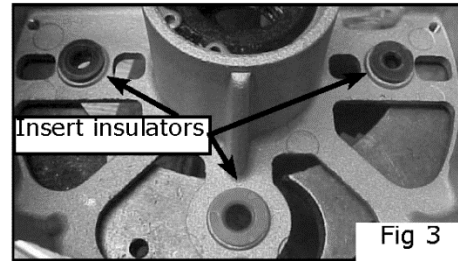

Step 4: Insert rectifier ring into rear housing making sure the insulating sleeve (Fig 2) doesn't fall off. While holding the rectifier in the housing, flip the housing and install the terminal hardware. (Fig 4)

Step 5: Flip housing over, route regulator sense leads per figure and attach to rectifier ring. (Fig 5)

Note: To determine polarity of regulator sense leads, look at the regulator wire colors connecting to the alternator. Trace these wires through the connector to determine correct polarity.

Red: Positive  
Black: Negative

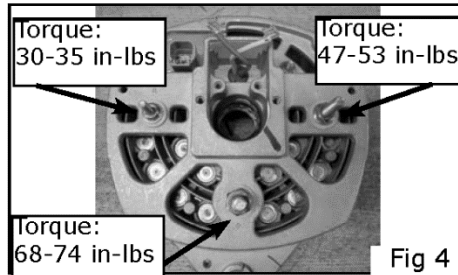

Step 6: On certain models solder leads to rectifier. (Fig 6)  
Recommended solder: SN15PB85

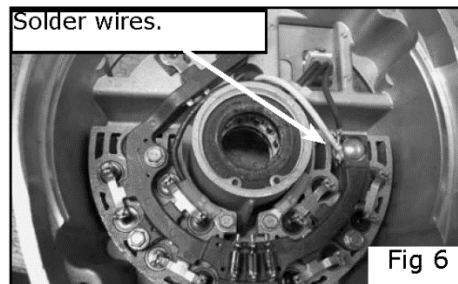
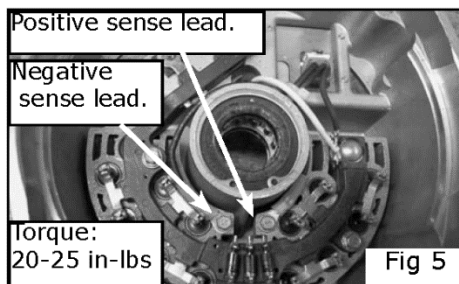
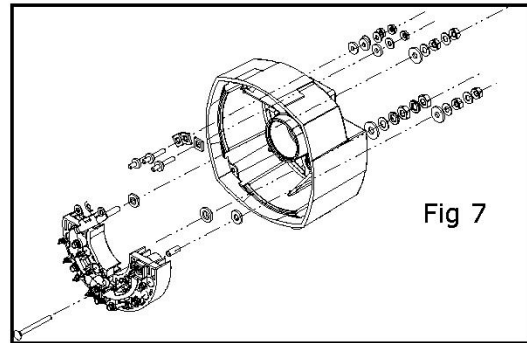
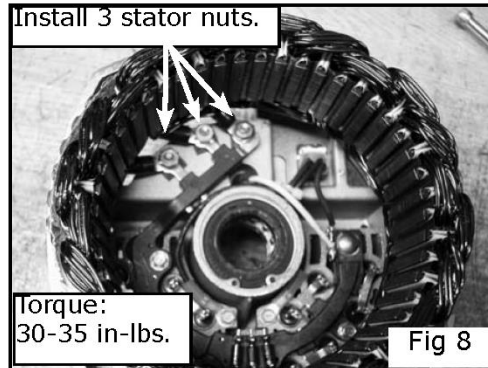

Figure 7 gives you an isometric view of the rear housing to show correct placement of components.



Step 7: Place stator into rear housing and attach three AC nuts. Torque nuts to 35-30 in-lbs. (Fig 8)



Step 8: Place front housing/ rotor assembly onto a flat surface. (Fig 9)

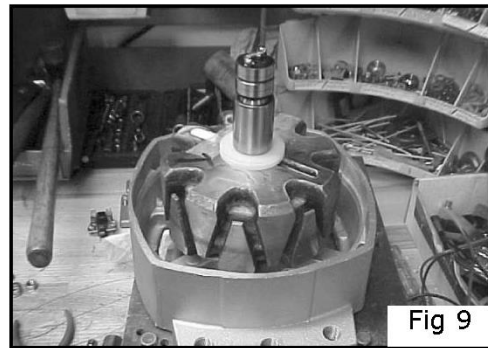

Step 9: Gently lower rear housing assembly onto front housing assembly. Wipe any grease contamination off the slipring. (Fig 10)

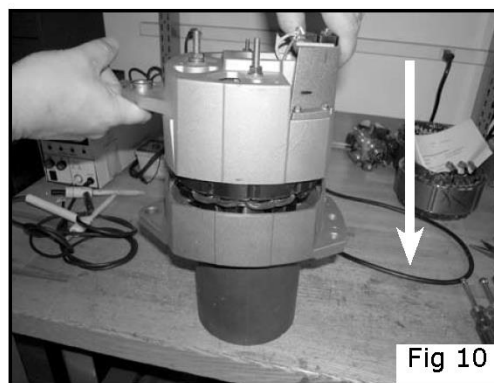

Note: Use caution not to damage the rear bearing seal when performing Step 9. (Fig 11)

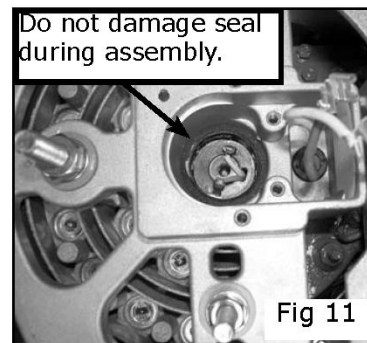

Step 10: Flip alternator over.  
Insert 1/2" alignment rod into mounting holes.  
(Fig 12)

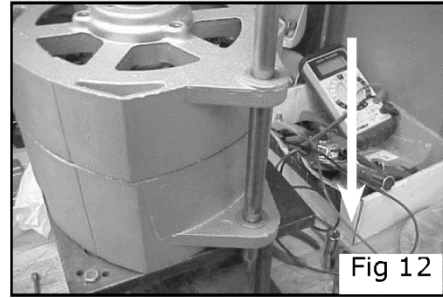

Step 11: Apply 242 locktite to alternator thru bolts.  
Install thru bolts and tighten to 45-40 in-lbs.  
Remove alignment rod. (Fig 13)

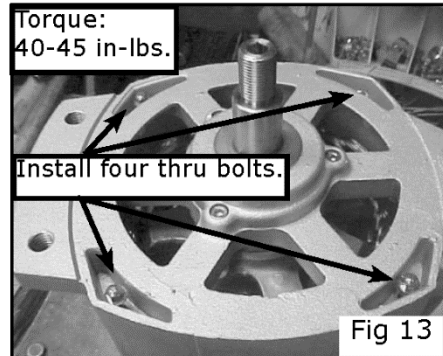

Step 12: Flip alternator over. Verify that the brush insulator shield is in place. (Fig 14)

Step 13: Install brushes and tighten screws.  
Connect field wires to brushes. (Fig 15)

Step 14: Install slip ring cover and gasket.  
Tighten screws. (Fig 16)

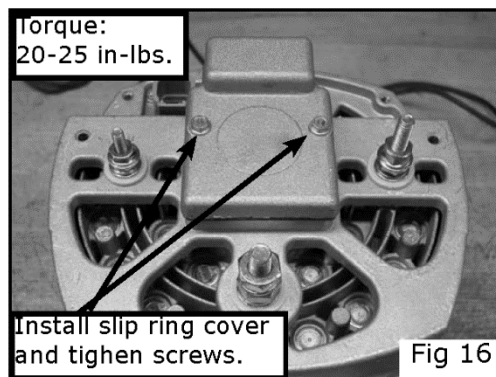
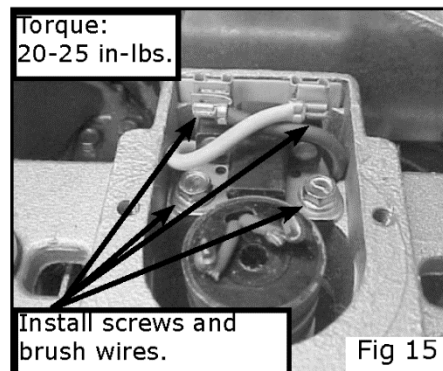
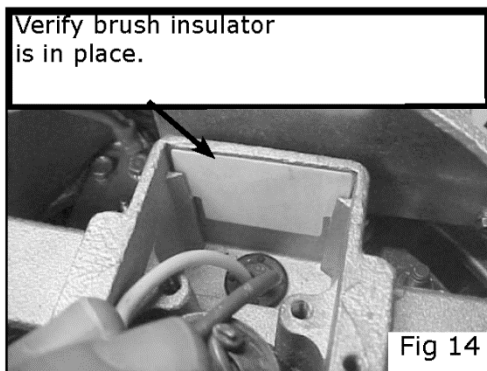

Step 15: Plug regulator into alternator and tighten mounting screws. (Fig. 17)

Step 16: Install trash screen if equipped. (Fig 18)

Step 17: Install fan.

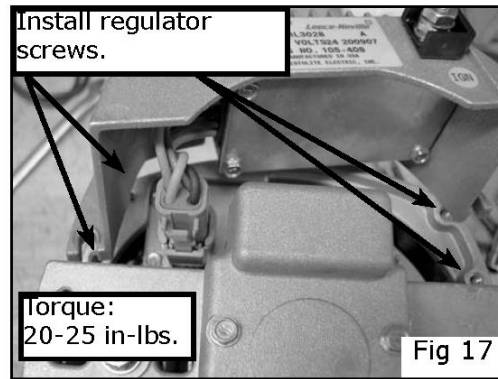
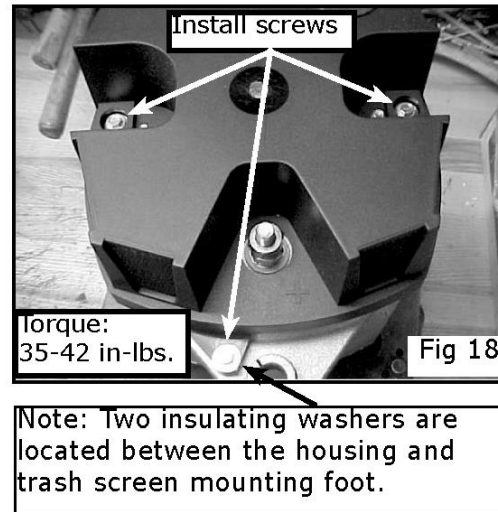
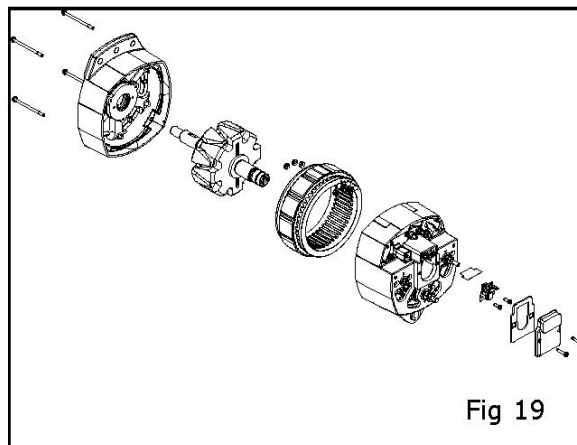

Figure 19 gives you an isometric view of the rear housing to show correct placement of components.



**Manufacturing OE Sales**

400 Main Street  
Arcade, NY USA 14009

Phone: (585) 492-1700

Fax: (585) 492-1660



**Distribution, Aftermarket Sales**

7585 Empire Drive  
Florence, KY USA 41042

Phone: (859) 525-8801

(800) 354-0560

Fax: (800) 997-6202





## **APPENDIX II**

**Delphi Battery Information  
Delco Battery Bulletin 1B-116  
Delphi MSDS**





**BATTERIES  
AND RELATED PARTS  
CONTAIN LEAD**

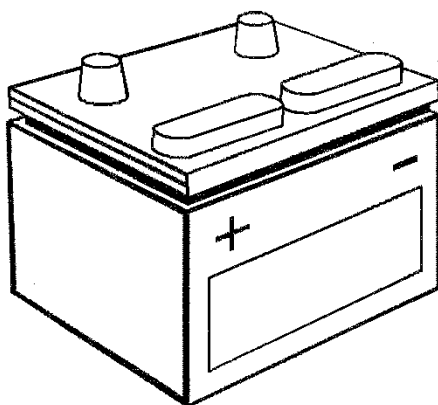

**WASH HANDS  
AFTER HANDLING**

**WARNING:** Battery posts, terminals and related accessories contain lead and lead components; chemicals known to the State of California to cause cancer and reproductive harm.

**SECTION I**

MANUFACTURER'S NAME: Delphi Energy and Chassis Systems  
 ADDRESS: Division of Delphi Automotive Systems  
 4800 S. Saginaw St.  
 Flint, MI 48501-1360

INFORMATION: 317-579-3354 Hrs. 8 - 4; M - F  
 EMERGENCIES - INFOTRAC: 1-800-535-5053

PREPARED BY: Delphi Automotive Systems  
 CREATION DATE: January 1, 1985  
 REVISED DATE: May1, 2000

TRADE NAME: Storage Battery, Wet  
 SYNONYMS: Lead/Acid Battery  
 CHEMICAL FAMILY: Liquid content - sulfuric acid  
 VOL/WGT: Varies with model

GM REFERENCE: FID: 121229

PRODUCT DESCRIPTION/USE: Electric Storage Battery

**SECTION II  
 COMPOSITION & INFORMATION ON INGREDIENTS**

| CAS #     | COMMON NAME                | WT%     | TLV<br>mg/m <sup>3</sup><br>ACGIH | PEL<br>mg/m <sup>3</sup><br>OSHA | OTHER<br>in<br>mg/m <sup>3</sup> |
|-----------|----------------------------|---------|-----------------------------------|----------------------------------|----------------------------------|
| 7439-92-1 | Lead                       | 50      | 0.05                              | 0.05                             | MSHA - air 0.15 TWA              |
| 7664-93-9 | Sulfuric acid              | 15      | 1                                 | 1                                | ACGIH STEL 3                     |
| 7732-18-5 | Water                      | 25      | None                              | None                             | None                             |
| Mixture   | Polypropylene/polyethylene | Balance | Not Est.                          | Not Est.                         | Not Est.                         |

**SECTION III  
 HAZARDS IDENTIFICATION**

Emergency Overview: Danger! Explosive gases. Poison causes severe burns.  
 Wet Storage Battery is a manufactured article composed of lead and acid encased in polypropylene, sealed and vented with a flame arrestor to reduce flashback potential. The case color varies. These batteries contain dilute sulfuric acid, a corrosive substance, and may expel explosive gases.

Routes of Entry: Skin: Yes Eye: Yes Inhalation: Yes Ingestion: Yes

**Acute/Chronic Health Effects:**

Skin: Sulfuric acid mists or liquid irritates the skin and may cause chemical burns. Severity depends on acid concentration and duration of contact.

Eyes: Sulfuric acid mists or liquid irritates the eyes and may cause chemical burns. Severity depends on acid concentration and duration of contact. Scarring of the cornea is possible.

Inhalation: Sulfuric acid mists irritate the nose and throat and may cause respiratory difficulty.

Ingestion: Sulfuric acid mists or liquid irritates the mucous membrane and may cause chemical burns. Repeated prolonged exposure may damage tooth enamel.

Medical Conditions Aggravated by Exposure to Sulfuric Acid: Pulmonary edema, bronchitis, emphysema, eczema, contact dermatitis, dental erosion and traceobronchitis.

#### SECTION IV FIRST-AID MEASURES

Skin: Flush the exposed skin with large amounts of water for 15 minutes. Remove contaminated clothing. Seek medical attention.

Eyes: Force eyes open and rinse with clean, cool, running water for 15 minutes. Do not use eye drops or other medication unless advised to do so by a doctor. Seek medical attention immediately after rinsing.

Inhalation: Remove from exposure. Seek medical attention.

Ingestion: Do not induce vomiting. If conscious, drink large quantities of milk or water. Follow with milk of magnesia, beaten egg, egg whites or vegetable oil. Seek medical attention immediately.

#### SECTION V FIRE-FIGHTING MEASURES

|                           |                |  |
|---------------------------|----------------|--|
| Flash Point:              | Not applicable | Flammable Limits: (Hydrogen Gas) 4.1 % LEL,<br>74.2% UEL |
| Autoignition Temperature: | Not applicable | Fire Point: Not applicable                               |

Extinguishing Media: Class ABC extinguisher, carbon dioxide, foam, halon, water spray.

Special Fire Fighting Procedures: Cool exterior of battery if exposed to fire to prevent rupture. Acid mists and vapors in a fire are corrosive. Wear protective clothing and use self-contained breathing apparatus (SCBA).

Unusual Fire and Explosion Hazards:

- Hydrogen and oxygen gases are produced during normal battery operation and charging. These gases escape through the battery vents and may form an explosive atmosphere around the battery if ventilation is poor. Avoid open flame, sparks and other ignition sources in areas where batteries are used or stored.
- Sulfuric acid is an oxidizer and can ignite combustibles upon contact.

Hazardous Combustion Products: Acid mists and vapors, toxic fumes from burning plastic.

HMIS Codes: Not determined

## SECTION VI ACCIDENTAL RELEASE OF MATERIAL

### Spill and Leak Procedures:

Small spill: Neutralize the spill with baking soda, household ammonia and/or water. Rinse clean.

Large spill: Remove combustible materials and all sources of ignition. Contain spill by diking with soda ash (sodium carbonate) or quicklime (calcium oxide). Cover spill with neutralizing agent such as soda ash or quicklime. Mix well. When mixture is neutral collect the residue in a suitable container and dispose of per local, state and federal waste regulations. Wear acid resistant boots, face shield, chemical splash goggles, and acid resistant gloves. Do not release unneutralized acid.

## SECTION VII HANDLING AND STORAGE

### Storage Temperature:

Min: -20°F (-28°C) for fully charged batteries. 20°F (-6°C) for completely discharged batteries.

Max: 80°F (26°C) for low shelf discharge but up to 100°F (38°C) is safe.

Shelf Life: Not determined.

Special Sensitivity: Avoid direct conductive connection across positive and negative terminals to prevent short circuit.

Storage Precautions: Batteries must be kept in an upright position away from ignition sources. Stack batteries so as to prevent accidental contact between terminal and/or other damage to terminals or containers. Whenever feasible, store on shipping pallet or rack. Do not stack loaded pallets or racks on top of other batteries. Store batteries in cool, well-ventilated location. Keep a supply of neutralizing agent in or near the storage area for emergency use. Avoid storage in areas exposed to heat or solar buildup. When batteries are completely discharged, the electrolyte will freeze when stored below 20°F. Fully charged batteries may be stored at temperatures as low as -20°F.

Handling Precautions: Use a battery carrier to lift battery or place hands at opposite corners to avoid spilling acid through the vents. Avoid contact with internal components of batteries. Do not tilt batteries to an angle greater than 45 degrees. Do not smoke when working near a battery.

## SECTION VIII EXPOSURE CONTROLS

Eye Protection: Chemical splash goggles or a full-face shield with safety glasses.

Skin Protection: Acid resistant clothing with rubber/neoprene boots for major spill clean up.

Respiratory Protection: Use NIOSH approved respiratory protection when concentrations exceed exposure guidelines.

Ventilation: Must be provided when charging in an enclosed area (29 CFR 1910.178 (g) and .305 (j)(7)).

Personal Protective Equipment: Lab apron, acid resistant steel-toed boots and protective clothing.

Engineering Controls: Local/building/fire codes may require explosion proof fans and equipment.

Workplace/Hygienic Practices: Upon skin contact, wash thoroughly with soap and water. Keep work areas clean.

Protective Gloves: Acid resistant gloves such as rubber, neoprene, vinyl coated, PVC.

### SECTION IX PHYSICAL AND CHEMICAL PROPERTIES

|   |  |
|---|--|
| Boiling Point: Not applicable   | Melting Point: >300°F/149°C for case               |
| Vapor Pressure at: Not applicable   | Specific Gravity: 1.280 at 77°F/25°C (electrolyte) |
| Solubility in Water: miscible (sulfuric acid)   | pH: < 1.0 (dilute sulfuric acid)                   |
| Appearance: A manufactured article cased in plastic with a sealed case, terminals and flame arrestor vent caps. Case color varies. Product is essentially odorless. |  |

### SECTION X STABILITY AND REACTIVITY

Stable: Yes

Stability - Conditions to Avoid: Use only approved charging methods. Avoid overcharging. Avoid short-circuiting. Avoid sparks and other ignition sources. Keep away from oxidizing and reducing materials. Do not open, break or melt the casing.

Incompatible Materials: Heat, open flames, sparks, strong oxidizing or reducing agents.

Hazardous Decomposition Products: Can emit highly toxic fumes when heated. Combustion can produce carbon dioxide and carbon monoxide. Will release an explosive hydrogen/oxygen gas mixture. Oxides of lead, lead and/or lead compounds may be released. Sulfuric acid may release sulfur dioxide and/or sulfur trioxide.

Hazardous Polymerization: Will not occur

Hazardous Polymerization - Conditions to Avoid: Not applicable

### SECTION XI TOXICOLOGY INFORMATION

Toxicology Data: Wet storage batteries are sealed articles. Exposure to lead, acid and lead contaminated acid is not anticipated during normal storage, handling and intended use or maintenance of the battery. Battery recycling personnel should carefully follow established employer protocols when processing batteries and battery components.

Eye Effects:

Sulfuric Acid - Severe eye irritant

**Skin Effects:**

Sulfuric Acid - Extremely irritating, corrosive, and toxic to tissue, resulting in rapid destruction of tissue, causing severe burns. If much skin is involved, exposure is accompanied by shock, collapse and symptoms similar to those seen in severe burns. Repeated contact with dilute solutions can cause dermatitis.

**Ingestion Effects:**

- Lead - Poison by ingestion in large dosages and with prolonged exposure leading to the same effects as seen in exposure by inhalation. Adults absorb 5-15% of ingested lead and retain less than 5%. Children absorb about 50% and retain about 30%.
- Sulfuric Acid - Moderately toxic by ingestion.

**Inhalation Effects:**

- Lead - For industry, inhalation is much more important than is ingestion. Systemic effects include loss of appetite, anemia, malaise, insomnia, headache, irritability, muscle and joint pains, tremors, flaccid paralysis without anesthesia, hallucinations and distorted perceptions, muscle weakness, gastritis and liver changes. Major organ systems affected are the nervous system, blood system and kidneys. Experimental evidence suggests that blood levels of lead below 10 µg/dL can lower the IQ scores of children. Low levels of lead impair neurotransmission and immune system function and may increase systolic blood pressure. Reversible kidney damage can occur from acute exposure. Chronic exposure can lead to irreversible vascular sclerosis, tubular cell atrophy, interstitial fibrosis, and glomerular sclerosis. Very heavy intoxication can sometimes be detected by formation of a dark line on the gum margins.
- Sulfuric Acid - Experimental poison by inhalation. Repeated or prolonged inhalation of sulfuric acid mist can cause inflammation of the upper respiratory tract, leading to chronic bronchitis. Severe exposure may cause chemical pneumonitis. Erosion of tooth enamel due to strong acid fume exposure has been observed in industry. Workers exposed to low concentrations of the vapors gradually lose their sensitivity to its irritating action.

**Carcinogenicity:**

| CAS #     | Name           | OSHA Listed | NTP Listed | IARC                         |
|-----------|----------------|-------------|------------|------------------------------|
| 7439-92-1 | Lead           | Yes         | No         | 2B, Human Limited Evidence   |
| 7664-93-9 | Sulfuric acid* | Yes         | No         | 1, Human Sufficient Evidence |

\* Occupational exposures to strong-acid mists containing sulfuric acid have been associated with several respiratory tract cancers. However, there is no animal data supporting the carcinogenicity of sulfuric acid. Sulfuric acid has been found to be non-mutagenic, and in two studies of workers employed in lead acid battery manufacture, no association between sulfuric acid mist exposure and respiratory tract cancers was observed.

**Mutagenicity:**

Lead - Human mutation data reported.

**Reproductive Effects:**

- Lead - Severe toxicity can cause sterility, abortion, and neonatal mortality and morbidity. Experimental teratogen. Experimental reproductive effects. Pathological lesions have been found on male gonads.
- Sulfuric Acid - Experimental teratogen.

## SECTION XII ECOLOGICAL INFORMATION

Ecotoxicological Information: Not applicable.

Distribution: Not determined.

Chemical Fate Information: Not determined.

## SECTION XIII DISPOSAL CONSIDERATIONS

RCRA Hazard Class: D002

Waste Disposal Method: Wet storage batteries are recyclable and should be turned over to a licensed battery recycler. Do not incinerate.

Sulfuric acid: Neutralize as for a spill; collect residue and place in suitable container; dispose as hazardous waste in accordance with local, state and federal regulations. Do not flush lead contaminated acid into the sewer.

## SECTION XIV TRANSPORT INFORMATION

### Canadian TDG Information

TDG Shipping Name: Batteries, Wet Filled with Acid

Hazard Class: 8

ID Number: UN 2794

Packing Group: III

Special Label or Marking Requirements: Corrosive

### U.S DOT Information

Proper Shipping Name: Batteries, Wet Filled with Acid

Hazard Class: 8

ID Number: UN 2794

Packing Group: III

RQ: N.A.

Special Label or Marking Requirements: Corrosive

### International Air Information (IATA Classification)

Proper Shipping Name: Batteries, Wet Filled with Acid

Hazard Class: 8

ID Number: UN 2794

Packing Group: III

Special Label or Marking Requirements: Corrosive

### International Ocean Information (IMO Classification)

Proper Shipping Name: Batteries, Wet Filled with Acid

Hazard Class: 8

ID Number: UN 2794  
 Packing Group: III  
 Marine Pollutant: No  
 Special Label or Marking Requirements: Corrosive

**SECTION XV  
 REGULATORY INFORMATION**

TSCA Inventory Status: All ingredients are listed on the EPA TSCA Inventory

EPA Hazard Categories:

Immediate (acute) health hazard: Yes  
 Delayed (chronic) health hazard: Yes  
 Fire hazard: No  
 Sudden release of pressure hazard: No  
 Reactive hazard: No

SARA 311/312: Extremely Hazardous Substances

| CAS #     | Name          | RQ       | TPQ      |
|-----------|---------------|----------|----------|
| 7664-93-9 | Sulfuric acid | 1000 lbs | 1000 lbs |

SARA 313: Specific Toxic Chemical Listings

| CAS #     | Name          | Percent |
|-----------|---------------|---------|
| 7439-92-1 | Lead          | 50%     |
| 7664-93-9 | Sulfuric acid | 15%     |

CERCLA Section 103: Hazardous Substances List

| CAS #     | Name          | Percent | RQ       |
|-----------|---------------|---------|----------|
| 7439-92-1 | Lead          | 50%     | 10 lbs   |
| 7664-93-9 | Sulfuric acid | 15%     | 1000 lbs |

Great Lakes Persistent Toxics - Metals:

| CAS #     | Name | Percent |
|-----------|------|---------|
| 7439-92-1 | Lead | 50%     |

Volatile Organic Compound (VOC): Not applicable

WHMIS: Controlled as a manufactured article.

Canadian Environmental Protection Act (CEPA):

| CAS #     | Name | Schedule          |
|-----------|------|-------------------|
| 7439-92-1 | Lead | I and III part II |

California Proposition 65 - Reproductive Toxicants

| CAS #     | Name | Percent |
|-----------|------|---------|
| 7439-92-1 | Lead | 50%     |

Proposition 65 Warning:

Battery posts, terminals, and related accessories contain lead and lead compounds, chemicals known to the State of California to cause cancer and reproductive harm. Wash hands after handling.



New Jersey Right-to-Know Hazardous Substances

| CAS #     | Name          | Percent |
|-----------|---------------|---------|
| 7439-92-1 | Lead          | 50%     |
| 7664-93-9 | Sulfuric acid | 15%     |

Massachusetts Substance List

| CAS #     | Name          | Percent |
|-----------|---------------|---------|
| 7439-92-1 | Lead          | 50%     |
| 7664-93-9 | Sulfuric acid | 15%     |

Pennsylvania Hazardous Substances

| CAS #     | Name          | Percent |
|-----------|---------------|---------|
| 7439-92-1 | Lead          | 50%     |
| 7664-93-9 | Sulfuric acid | 15%     |

Ontario Designated Substance

| CAS #     | Name | Percent |
|-----------|------|---------|
| 7439-92-1 | Lead | 50%     |

EINECS: Not determined

**SECTION XVI  
OTHER INFORMATION**

Label Information:

**DANGER!** Explosive Gases: Always shield eyes and face from battery. Cigarettes, flames, sparks could cause battery to explode. Do not charge or use booster cables or adjust post connections without proper instruction and training.

**POISON!** Causes severe burns: Contains sulfuric acid. Avoid contact with skin, eyes or clothing. In event of accident flush with water and call a physician immediately. Do not tip. Keep out of reach of children.

*End of MSDS*

# Delco Remy FREEDOM BATTERIES

(TERMINAL LOCATIONS ON TYPICAL BATTERY SHOWN IN FIGURE 5)

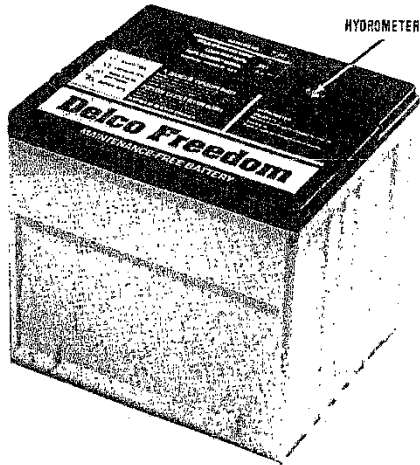

Figure 1—Typical Passenger Car Freedom Battery with Sealed Terminals

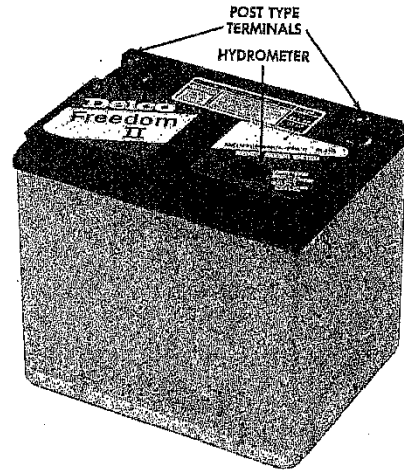

Figure 2—Typical Passenger Car Freedom Battery with Posts

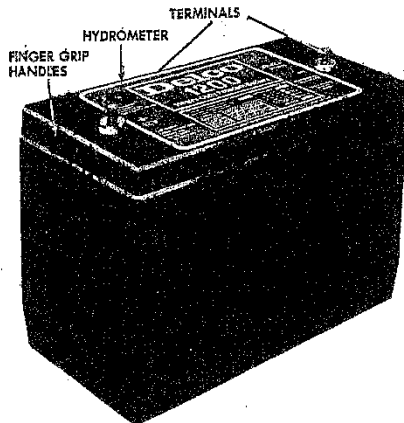

Figure 3—Typical Heavy-Duty Freedom Battery

## TABLE OF CONTENTS

|                                 |        |
|---------------------------------|--------|
| General Information .....       | Page 2 |
| Built-in Hydrometer .....       | Page 3 |
| Battery Testing Procedure ..... | Page 4 |
| Battery Charging .....          | Page 6 |
| Troubleshooting .....           | Page 7 |
| Emergency Starting .....        | Page 7 |

**Delco Remy**

DIVISION OF GENERAL MOTORS CORPORATION, ANDERSON, INDIANA



# FREEDOM BATTERIES

## 1B-116 Service Bulletin

### GENERAL INFORMATION

The Freedom Batteries shown in Figures 1 and 2 are widely used in passenger car and light-duty truck applications. Figure 3 shows a heavy-duty Freedom Battery used in diesel engine trucks and other heavy-duty applications.

Water never needs to be added to the Freedom Battery. There are no filler caps in the cover. The battery is sealed, except for small vent holes in the cover. The vents allow what small amount of gasses that are produced in the battery to escape. The special chemical composition inside the battery reduces gassing to a very small amount at normal charging voltages. Besides reducing gassing, the special chemistry greatly reduces the possibility of overcharge damage.

The vents require keeping the battery in an upright position to prevent electrolyte leakage. Tipping the

battery beyond a 45° angle in any direction can allow a small amount of electrolyte to leak out the vent hole.

**DO NOT** exceed this 45° angle when carrying or installing the battery.

Evidence of electrolyte leakage does not necessarily mean the battery is defective.

With special cables properly attached to batteries in Figures 1 and 3, the metal surfaces that carry the current are completely sealed from the atmosphere. This prevents terminal oxidation and corrosion that would cause starting and charging problems. If new cables are needed, sealed terminal cable replacements should be used to retain the reliability of the original maintenance-free connection. For the battery in Figure 1, torque studs to 5-10 lb.-ft. (7-13Nm). For Figure 3, torque cables

to 10-15 lb.-ft. (13-20Nm).

The battery in Figure 2 features top post terminals. Clean cable clamps should be securely tightened to posts. Grease or special spray sealers may be applied over the connections.

With the correct cables properly attached, and with the battery properly mounted, the Freedom Battery never needs any periodic maintenance attention.

**WARNING**—All lead-acid batteries generate hydrogen gas which is highly flammable. If ignited by a spark or flame, the gas may explode violently, causing spraying of acid, fragmentation of the battery, and possible severe personal injuries. Wear safety glasses when working near batteries. In case of contact with acid, flush immediately with water.

## BUILT-IN HYDROMETER

A special temperature-compensated hydrometer is built into the cover of Freedom Batteries to show at a glance the battery's state-of-charge. The hydrometer has a green ball within a cage which is attached to a clear plastic rod (Figure 4). The green ball will float at a predetermined specific gravity of the electrolyte that represents about a 65% state-of-charge. When the green ball floats, it rises within the cage and positions itself under the rod. Visually a green dot then shows in the center of the hydrometer (Figure 4). The built-in hydrometer provides a guide for battery testing and charging.

In testing, the green dot means the battery is charged enough for testing. If the green dot is not visible, dark appearance (Fig. 4), it means the battery must be charged before

the test procedure is performed.

In charging, the appearance of the green dot means that the battery is sufficiently charged. Charging can be stopped to prevent overcharging.

The hydrometer on some batteries may be clear or light yellow (Fig. 4). This means the fluid level may be below the bottom of the rod and attached cage. This may have been caused by excessive or prolonged charging, a broken case, excessive tipping, or normal battery wearout. Whenever this clear or light yellow appearance is present while looking straight down on the hydrometer, always tap the hydrometer lightly with a small screwdriver to dislodge any gas bubbles that may be giving a false indication of low electrolyte level. If the clear or light yellow appearance remains, and if a crank-

ing complaint exists that is caused by the battery, replace it.

It is important when observing the hydrometer that the battery have a clean top to see the correct indication. A flashlight may be required in some poorly-lit areas. **Always look straight down when viewing the hydrometer.**

On some special applications, some hydrometers feature a red dot indication in addition to the green dot, dark, and clear appearances. The red dot means the battery is nearing complete discharge and must be charged before being used in service.

Complete hydrometer information on most batteries is printed on the label located on the top of the battery. By referring to this label, an accurate interpretation of the hydrometer appearance can be made.

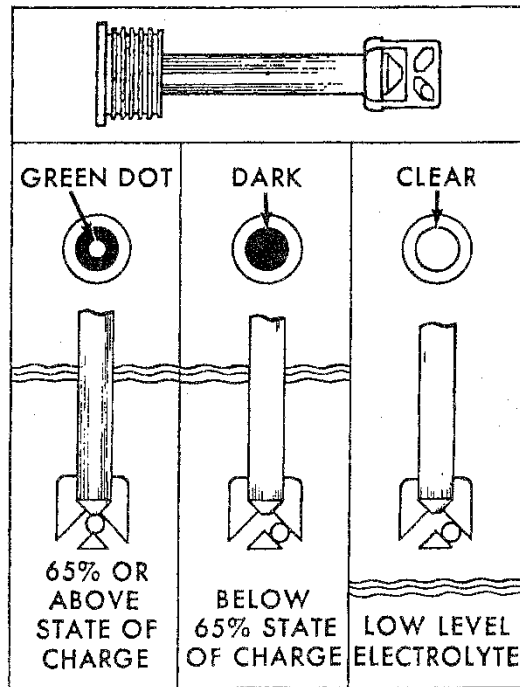

Figure 4—Typical Hydrometer Operation

# FREEDOM BATTERIES

## 1B-116 Service Bulletin

### TESTING THE FREEDOM BATTERY

#### Step 1—VISUAL INSPECTION:

Check for obvious damage such as cracked or broken case or cover that could permit loss of electrolyte. If obvious physical damage is noted, replace battery. Determine cause of damage and correct as needed.

#### Step 2—BUILT-IN HYDROMETER (State-of-charge) CHECK:

Observe the build-in hydrometer and proceed as follows:

- A. Green Dot Visible—means a sufficient state-of-charge for testing is indicated. Proceed to Step 3.
- B. Dark, Green Dot NOT VISIBLE—indicates insufficient state-of-charge for testing. Charge battery (as discussed in "Battery Charging" section) until the green dot appears, then proceed to Step 3.

#### Step 3—LOAD TEST:

- A. Connect voltmeter and battery load tester across terminals of battery as follows:

1. Freedom Battery (Fig. 1)—If more than one battery in the vehicle, check each battery separately by disconnecting batteries from each other. If Freedom Battery is in the vehicle, connect battery tester cable clamps to terminal studs, being careful to NOT TOUCH BARE METAL of the clamp attached to positive battery terminal to the metal of the vehicle—sparking will occur. If the Freedom Battery is OUT of the vehicle, assemble adapters (Fig. 5) and connect tester clamps to the adapters.
2. Freedom Battery (Fig. 2)—Remove cable clamps and be sure parts are clean for a good connection. Attach tester clamps to posts.
3. Freedom Battery (Fig. 3)—Cables to these batteries must be disconnected. If adapters are available, assemble onto battery as shown in Figure 6.

Connect tester clamps to adapters. If adapters are not available, attach load clamps to contact lead pads (Figs. 7 & 8). Tighten hex nuts down to hold clamps against lead pads. If clamps cannot physically touch the lead pads, then the load current MUST BE DECREASED as described in Service Bulletin 1B-188.

- B. Remove surface charge from all batteries that have just been on charge IF THE GREEN DOT IS VISIBLE. This includes batteries in the vehicle having been charged by the vehicle generator.

Do not remove surface charge from batteries that have been in storage.

To remove surface charge, apply a 300-ampere load across the terminals for 15 seconds. Then turn off load and wait for 15 seconds to allow the battery to recover.

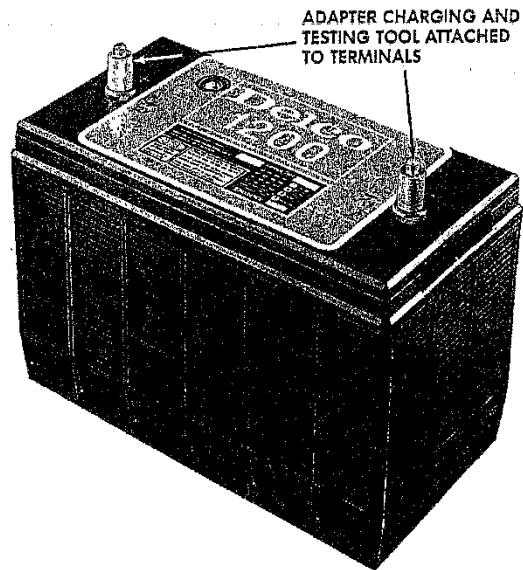
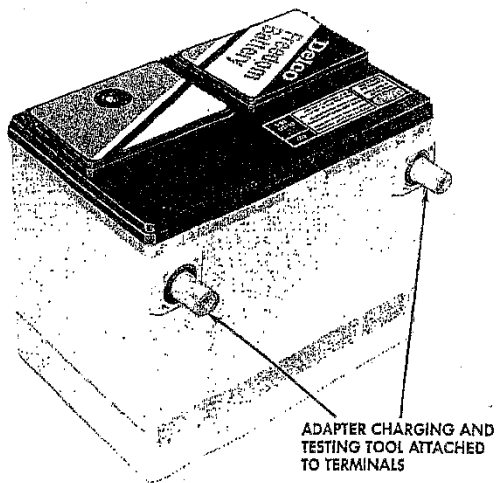

Figures 5 and 6—Adapter Charging Tool (AC-Delco ST-1201) for testing and charging Freedom Battery

# FREEDOM BATTERIES

## Service Bulletin 1B-116

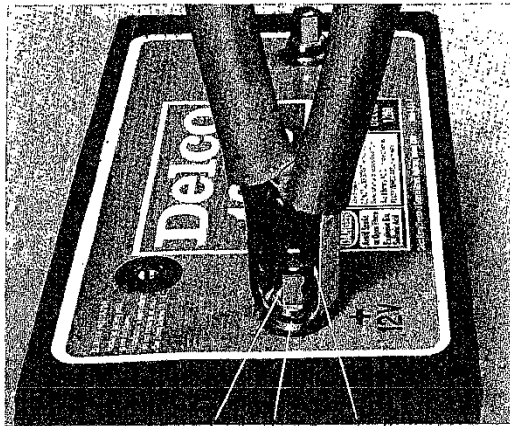

HEX NUT  
ALLIGATOR CLAMPS  
LEAD PAD

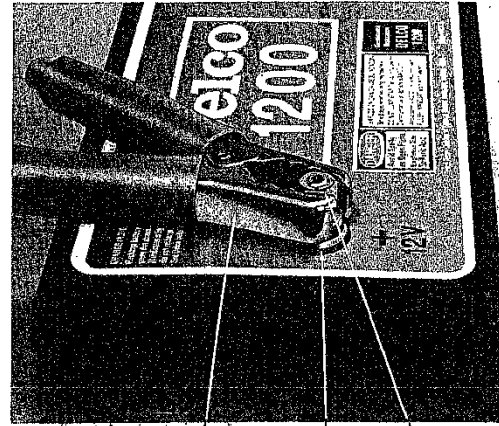

ALLIGATOR CLAMPS  
LEAD PAD  
HEX NUT

Figures 7 and 8—Alligator clamps contacting lead pad for testing and charging Heavy Duty Battery

C. Battery temperature should be estimated by touch and also by the surrounding temperature it was exposed to during the preceding few hours before testing. Select the nearest estimated temperature in the table below and determine the minimum voltage which must be maintained while the battery supplies a specified electrical load (see section "D" following).

| Temperature     | (21° C)<br>70° F &<br>Above | (10° C)<br>50° F | (-1° C)<br>30° F | (-10° C)<br>15° F | (-18° C)<br>0° F | Below<br>0° F |
|-----------------|-----------------------------|------------------|------------------|-------------------|------------------|---------------|
| Minimum Voltage | 9.6                         | 9.4              | 9.1              | 8.8               | 8.5              | 8.0           |

D. Apply specified load selected from Specifications Bulletin 1B-188. (On most batteries the specified load is printed on the label of the battery.)

1. Observe voltage after 15 seconds with load connected. Then turn off load.
2. If voltage is below value determined in part C above, replace battery.
3. If voltage is at or above value determined in part C above, battery is good and may be returned to service.

NOTE: The accuracy of this test procedure is dependent upon close adherence to the proper load, time and temperature specifications.

## FREEDOM BATTERIES

### Service Bulletin 1B-116

## BATTERY CHARGING

The adapter kit shown in Figures 5 and 6 is available from AC-Delco, Part No. ST-1201. It is recommended that this adapter kit, or equivalent, be used in charging sealed-terminal batteries when they are out of the vehicle.

When the sealed-terminal battery is in the vehicle, connect the charger's leads to the studs or nuts at the battery's terminals. Post-type batteries need no adapters.

The following basic rules apply to any Freedom Battery charging situation:

- Do not charge a battery if the hydrometer is clear or light yellow—replace the battery.
- Charge rates between 3 and 50 amperes are generally satisfactory for any Freedom Battery as long as spewing of electrolyte does not occur or the battery does not feel excessively hot (over 125°F, 52°C). If spewing occurs or temperature exceeds 125°F, the charging rate must be reduced or temporarily halted to permit cooling. Battery temperature can be estimated by touching or feeling the battery case.

—The battery is sufficiently charged when the green dot in the built-in hydrometer is visible. No further charging is required. Shake or tilt the battery at hourly intervals during charging to mix the electrolyte and see if the green dot appears.

—Battery charging consists of a charge current in amperes for a period of time in hours. Thus, a 25-ampere charging rate for 2 hours would be 50 ampere-hour charge to the battery. In most cases, batteries whose load test values are less than 200 amperes (see Battery Testing Procedure) will have the green dot visible after at least a 50 ampere-hour charge. Most batteries whose load test values are greater than 200 amperes (see Battery Testing Procedure) will have the green dot visible after at least a 75 ampere-hour charge. In the event that the green dot does not appear after this amount of charging, continue charging for another 50 or 75 ampere-hours. If the green dot still does not appear, replace the battery.

The time required for a charge will vary because:

*Size of Battery*—Example: A completely discharged large Heavy-Duty Battery requires more than twice the recharging as a completely discharged small Passenger Car battery.

*Temperature*—Example: A longer time will be needed to charge any battery at 0°F than at 80°F. When a fast charger is connected to a cold battery, the current accepted by the battery will be very low at first, then in time the battery will accept a higher rate as the battery warms.

*State-of-Charge*—Example: A completely discharged battery requires more than twice as much charge as a one-half-charged battery. Because the electrolyte is nearly pure water and a poor conductor in a completely discharged battery, the current accepted is very low at first. Later, as the charging current causes the electrolyte acid content to increase, the charging current will likewise increase.

*Charger Capacity*—Example: A charger which can supply only 5 amperes will require a much longer period of charging than a charger that can supply 30 amperes or more.

## TROUBLESHOOTING

If a battery has tested good and then has not performed satisfactorily in service for no apparent reason, the following are some of the more important factors that may point to the cause of trouble:

1. Vehicle accessories inadvertently left on overnight.
2. Defects in the charging system, such as slipping fan belt, high wiring resistance, faulty generator or regulator.
3. A vehicle electrical load exceeding the generator capacity, with the addition of electrical devices, such as radio equipment, air-condition, window defoggers or light systems.
4. Defects in the electrical system, such as shorted wires.
5. Extended slow speed driving with many accessories turned on.
6. Loose or poor battery cable-to-post connections, previous improper charging of a run-down battery, or loose hold-downs.
7. High-resistance connections or defects in the cranking system.
8. Long periods of vehicle storage without disconnecting the battery or batteries. Small current drains of vehicle accessories which are connected all the time can discharge the battery or batteries in a six- to eight-week period. Batteries left in a discharged condition for a prolonged period of time are subject to freezing and can become difficult to recharge.

## JUMP STARTING IN CASE OF EMERGENCY WITH AUXILIARY (BOOSTER) BATTERY

Both booster and discharged battery should be treated carefully when using jumper cables. Follow exactly the procedure outlined below, being careful not to cause sparks:

1. Set parking brake and place automatic transmission in "PARK" (neutral for manual transmission). Turn off lights, heater and other electrical loads. Observe charge indicator. If indicator is light, replace battery. If charge indicator is dark and has a green dot in the center, failure to start is not due to a discharged battery and the cranking system should be checked. If charge indicator is dark but the green dot does not appear in center, proceed as follows:

### NEGATIVE GROUND ONLY

2. Attach one end of one jumper cable to the positive terminal of the booster battery and the other end of same cable to positive terminal of discharged battery. **DO NOT PERMIT** vehicles to touch each other as this could establish a ground connection

and counteract the benefits of this procedure.

3. Attach one end of the remaining negative cable to the negative terminal of the booster battery and the other end to a ground at least 12 inches from the battery of the vehicle being started. (**DO NOT CONNECT DIRECTLY TO THE NEGATIVE POST OF THE DEAD BATTERY.**)

### POSITIVE GROUND ONLY

4. Attach one end of one jumper cable to the negative terminal of the booster battery and the other end of the same cable to negative terminal of discharged battery. **DO NOT PERMIT** vehicles to touch each other, as this could establish a ground connection and counteract the benefits of this procedure.
5. Attach one end of the remaining positive cable to the positive terminal of the booster battery and the other end to a ground at least 12 inches from the battery of the vehicle being started. (**DO**

**NOT CONNECT DIRECTLY TO THE POSITIVE POST OF THE DEAD BATTERY.)**

### NEGATIVE GROUND AND POSITIVE GROUND

6. Take care that the clamps from one cable do not inadvertently touch the clamps on the other cable. Do not lean over the battery when making connections. The ground connection must provide good electrical conductivity and current carrying capacity. Avoid moving hot or electrical hazards such as fans, manifolds and spark plug terminals.
7. Reverse this sequence exactly when removing the jumper cables.

**WARNING:** Any procedure other than the above could result in: 1) personal injury caused by electrolyte squirting out the battery vent, 2) personal injury or property damage due to battery explosion, 3) damage to the charging system of the booster vehicle or of the immobilized vehicle.





## Battery Servicing and Charging Information

### **▲ DANGER/POISON – Observe All Safety Precautions!**

Maintenance free automotive and heavy duty batteries contain sulfuric acid and lead, and produce explosive gases during charging and use. They can produce current levels high enough to cause burns. Failure to read and observe these safety precautions and those shown on battery labels can result in serious personal injury including blindness, or damage to the battery or other property:

- **Shield Eyes.** Always wear suitable eye protection to protect against flying debris and acid in the event of an explosion.
- **No Sparks, Flame, or Smoking.** Keep everything that might ignite explosive gases away from batteries. Be sure testers, chargers, and other equipment are turned OFF before connecting them to the battery. Always disconnect the negative terminal first and connect the negative terminal last. Follow published jump starting procedures exactly.
- **Sulfuric Acid can cause Blindness or Severe Burns.** If acid from the battery gets in your eyes or on your skin, flush it away immediately with plenty of water and get medical help fast. To clean acid from environmental surfaces, neutralize it first with a solution of baking soda in water and then rinse it away with plenty of plain water.
- **Do not Open the Battery or Tilt it Beyond 45°.** Keep the acid inside the battery. Do not cut or purposely break the case. Keep the battery within 45 degrees of upright to prevent acid from leaking out through the internal vent system.
- **California Proposition 65 Warning:** Battery Posts, terminals, and related accessories contain lead and lead compounds, chemicals known to the State of California to cause cancer and reproductive harm. **Wash hands after handling.**
- **Battery Terminals are "Live at all Times."** Batteries produce high levels of current. If the battery terminals or wires connected to them are accidentally shorted together, the shorting device or wires can quickly become hot enough to cause skin burns. Never let wires connected directly to the terminals touch each other, and keep insulating terminal protectors in place to help prevent accidental shorting when the battery is not in use.
- **Dispose of Batteries Properly:** Automotive and heavy duty lead-acid batteries are considered hazardous material by various governmental agencies. Always follow local environmental laws regarding disposal, and never try to ship or transport a battery without disclosing to the carrier that it is hazardous material. Various regulations and penalties may apply. Dispose of unwanted units only through an approved battery recycler.
- **Always Keep Batteries Out of the Reach of Children.**

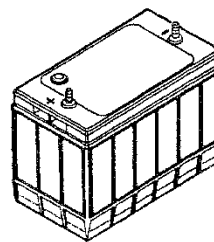

### GENERAL INFORMATION

#### **Battery Storage**



Store un-used batteries in a cool location. Avoid storage in areas exposed to heat or solar buildup. Cool temperatures will reduce self-discharge

Check the battery's built-in hydrometer every 90-120 days and charge as necessary. If the stored battery has no hydrometer, recharge it any time the open circuit voltage (OCV) falls below 12.45 volts.

#### **Vehicle Storage**

For storage of 20 days or longer, disconnect the battery ground cable. Check the battery's built-in hydrometer or OCV every 90-120 days and recharge as necessary.

If the ground cable cannot be disconnected, check the battery's hydrometer or OCV every 20-45 days and recharge as necessary.

| Hydrometer Indication  | State of Charge | Required Action |
|--|-----------------|-----------------|
| <br>Green Dot | Above 65%       | Load Test       |
| <br>Dark Dot  | Below 65%       | Charge Battery  |
| <br>Clear Dot | Low Electrolyte | Replace Battery |

### BEFORE CHARGING OR TESTING:

#### **Perform Visual Inspection**

- **Inspect the battery case for damage or cracks.**  
Replace the battery if it is found to be broken. Always check the area around and under the battery for signs of damage due to leaking acid. Neutralize residual acid with a solution of baking soda and water, then rinse thoroughly with plain water. Eliminate the cause of the breakage before installing a replacement battery.
- **Inspect for loose, broken, or corroded terminals.**  
If a battery problem has been reported, disassemble the terminal connections and clean the connecting surfaces with a wire brush until shiny metal appears. For best results, charge and test the battery as required BEFORE reconnecting the terminals to the vehicle to prevent other vehicle conditions from causing erroneous test results.
- **Inspect for proper hold-down installation.**

Check the hold-down installation in the vehicle and assure that the battery is held securely. A loose or unsound hold-down can cause the battery to be damaged by high levels of vibration. Correct as needed.

#### **Using the Built-In Hydrometer.**

The built-in hydrometer provided in several battery models gives valuable information about the battery status. Refer to the table for interpretation.

The built-in hydrometer reads the specific gravity and remaining supply of the electrolyte in one cell. In a properly-functioning battery, all cells will be approximately the same. By using the hydrometer, the user can quickly verify that the battery contains sufficient electrolyte and know whether it is in a usable or testable state of charge. The green dot **does not** indicate whether the battery is "good" or "bad." It only indicates the state of charge and electrolyte level in one cell of the battery.

Always load test the battery to determine whether the entire battery is working properly.

**Stored Batteries** should always be kept at a state of charge of 65% or higher. The built-in hydrometer shows at a glance whether this level of charge is being maintained.

**Troubleshooting** a vehicle no-start condition is simplified. If the hydrometer shows the state of charge is below 65%, the battery may be too discharged for effective starting in extreme conditions. In any case, a battery should always have a 65% or higher state of charge (green dot visible) before returning it to normal service.

**Load Testing** batteries is simplified. Conventional load testing requires that the battery be at 65% of full charge or above for reliable results. If the green dot is visible in the hydrometer, the battery is ready for load testing.

A yellow or clear indication in the center of the hydrometer means the electrolyte level is low inside the battery. The most likely cause is overcharge. Replace the battery, but check the vehicle's charging system for proper voltage regulation according to manufacturer's instructions before returning the vehicle to service.

If the battery is NOT equipped with a built-in hydrometer, the battery's state of charge is determined by using a voltmeter to read the OCV (open circuit voltage). An accurate OCV reading can only be obtained when there is no current flowing into or out of the battery. Also, a battery that has been recently charged or discharged may give a false OCV reading because the voltage is not stabilized. Use the following guidelines:

**NOTE:** For the best voltmeter, tester, and charger operation, disconnect the battery terminals and wire brush them until a shiny metal surface appears before attaching any such equipment. For threaded terminals, install suitable adapters - don't connect testers or chargers directly to the threads.

Tool required: Voltmeter

1. Be sure all electrical loads are OFF. The best way to assure this is to disconnect the negative battery cable.
2. Wait for at least 15 seconds after the battery was last discharged.
3. Use a voltmeter to check the OCV.
  - If the reading is below 12.45 volts, the battery is below 65% state of charge.
  - If the reading is 12.45 volts or higher and the battery has been charged or used in a vehicle within the past 12 hours, connect a carbon pile load test. Apply a 300-ampere load for 15 seconds. Turn the load OFF and allow the battery to recover for at least 15 seconds. If the OCV reading is still 12.45 volts or higher, the battery is at 65% state of charge or higher. If the OCV is now lower than 12.45, the battery is below 65% state of charge.
  - If the reading is 12.45 or higher and the battery has not been used or charged within the past 12 hours, it is 65% of full charge or higher.

#### Load Testing (Observe all Safety Precautions!)

Many types of battery testing equipment are available. Most of these testers give reliable results when used according to the tester manufacturer's instructions. Either the CCA (Cold Cranking Amp) or Load Test rating is entered into the tester. Both are printed on the label for reference. The standard Load Test is described below:

**Tools Required:** Variable Carbon Pile Load Tester, 15-Second Timer, Voltmeter, and Ammeter.

1. Be sure the battery state of charge is 65% or higher.
2. With the load turned OFF, connect the load tester and voltmeter across the battery terminals. Connect the ammeter in series with the battery.
3. Turn the load ON and adjust the current to the **LOAD TEST** value shown on the battery label.
4. As soon as the load value is attained, start the timer.
5. At the end of 15 seconds, read the voltage across the battery terminals. Write down the voltage reading.
6. Turn OFF the load and then disconnect the battery.
7. Estimate the battery's internal temperature by the average temperature to which the battery has been exposed over the

last 12 hours. Use the following table to determine the minimum acceptable voltage:

| Battery Temperature | 70°F | 50°F | 30°F | 15°F | 0°F | Below 0°F |
|---------------------|------|------|------|------|-----|-----------|
| Minimum Voltage     | 9.6  | 9.4  | 9.1  | 8.8  | 8.5 | 8.0       |

8. If the Load Test voltage is below the minimum shown, replace it. If the voltage is above the minimum, it is a good battery.

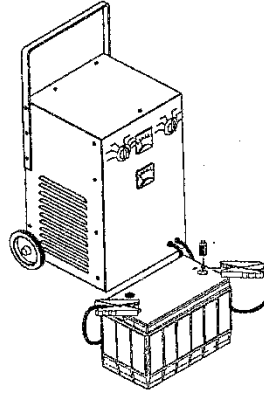

#### Single Battery Charging

(Observe all Safety Precautions!)

Batteries may be charged using virtually any type of automotive battery charger. A high output single battery charger that senses when the battery reaches full charge and automatically stops the charge or switches to a float charge status is recommended. The time required for charging will vary with the size of the battery, the depth of discharge, the battery temperature, and the charger capacity.

**Tools Required:** Battery Charger, Voltmeter

1. For best results, disconnect the battery from the vehicle. This will assure that all of the charger's energy is being delivered to the battery and prevent any high resistance cable connections from limiting the charge. Use adapters on threaded terminals.
2. Check the OCV with the voltmeter. If the voltage is below 11 volts indicating the battery is very discharged, it may be some time before the charging current is measurable.
3. With the charger turned OFF, connect it to the battery terminals.
4. Turn the charger ON.
5. Monitor the charging battery each hour.
6. If the battery feels hot to the touch (over 125°F) or there is gassing or spewing of electrolyte from the vent, check the voltage across the terminals then stop the charge. If the charging voltage was above 16 volts, a lower charging voltage may be needed. Allow the battery to cool before resuming the charge.
7. Charge the battery until the charger indicates full charge has been reached (refer to charger manufacturer's instructions). If the charger is not an automatic taper-rate type, full charge is reached when the charging voltage is 16 volts and the charging current is 5 amperes or below. The battery is also charged when the green dot appears in the hydrometer.
8. If the battery is equipped with a built-in hydrometer, the green dot will probably be in view when the charger indicates full charge. If it is not (particularly with lower-output chargers), slow mixing of electrolyte may have delayed the hydrometer's response.

#### Multiple Battery Charging (Observe all Safety Precautions!)

Parallel charging is the preferred method for charging multiple batteries. Use the following guidelines:

- Be sure the output of the charger can deliver a minimum of 10 amperes to each battery.
- Set the charger output at 16 volts.
- Monitor each battery in the hookup on an hourly basis. If the battery feels hot to the touch (over 125°F) or is gassing or spewing electrolyte from the vent, stop the charge and remove that battery from the circuit to cool.
- When the green dot appears and remains in view in the built-in hydrometer, the battery is charged. If the battery is not equipped with a hydrometer, it will be fully charged when the charging current into that single battery is 5 amperes or below when charging at 16 volts.

**DELPHI**  
Automotive Systems