

Model: 1158-1100 (5008-56)
50 Ton (45.4 Metric Ton)
Alligator Axle Jack

04/2018 – Rev. 01

REVISION
01

DATE
04/2018

TEXT AFFECTED
Original release

TABLE OF CONTENTS

	<u>PAGE</u>
1.0 PRODUCT INFORMATION	1
1.1 DESCRIPTION.....	1
1.2 MODEL & SERIAL NUMBER.....	1
1.3 MANUFACTURER	1
1.4 SPECIFICATIONS	1
2.0 SAFETY INFORMATION.....	1
2.1 USAGE AND SAFETY INFORMATION	1
2.2 PRODUCT SAFETY	1
3.0 PREPARATION PRIOR TO FIRST USE	1
3.1 GENERAL INSPECTION	1
3.2 BLEED PROCEDURE	1
4.0 TRAINING	2
4.1 TRAINING REQUIREMENTS	2
4.2 TRAINING PROGRAM	2
4.3 OPERATOR TRAINING	2
5.0 OPERATION.....	2
5.1 PRE-OPERATION PROCEDURE.....	2
5.2 LIFTING PROCEDURE	2
5.3 LOWERING PROCEDURE.....	2
5.4 RELIEF VALVE SETTING	2
6.0 TROUBLE SHOOTING	3
7.0 MAINTENANCE.....	4
7.1 SPECIAL MAINTENANCE INSTRUCTIONS	4
7.2 SHOP AIDS AVAILABLE	4
7.3 OVERHAUL KITS AVAILABLE	4
8.0 PROVISION OF SPARES.....	4
8.1 SOURCE OF SPARE PARTS.....	4
8.2 RECOMMENDED SPARE PARTS LISTS	4
9.0 IN SERVICE SUPPORT.....	4
10.0 GUARANTEES/LIMITATION OF LIABILITY	5
11.0 APPENDICES	5

This product can not be modified without the written approval of Tronair, Inc. Any modifications done without written approval voids all warranties and releases Tronair, Inc., its suppliers, distributors, employees, or financial institutions from any liability from consequences that may occur. Only Tronair OEM replacement parts shall be used.

1.0 PRODUCT INFORMATION

1.1 DESCRIPTION

50 Ton (45.4 Metric Ton) Axle Jack

1.2 MODEL & SERIAL NUMBER

Reference nameplate on unit

1.3 MANUFACTURER

Columbus**Jack**/Regent
1 Air Cargo Pkwy East
Swanton, Ohio 43558 USA

Telephone: 614.443.7492
Fax: 614.444.9337
E-mail: sales@columbusjack.com
Website: www.columbusjack.com

1.4 SPECIFICATIONS

Capacity 50 Ton (45.4 Metric Ton)
Minimum Height 8.5 in (21.59 cm) with adapter 10.5 in (26.67 cm)
Hydraulic Lift 9.75 in (24.77 cm)
Screw Extension 4 in (10.16 cm)
Maximum Height 22.25 in (56.52 cm) with adapter 24.25 in (61.6 cm)
Estimated Weight 337 lbs (152.9 kg)
Operating Pressure 8065 psi (556 bar)
Relief Valve Pressure 8872 psi (611.7 bar)
Air Requirements Pressure: 80 psi (5.5 bar) minimum
Flow: 40 Scfm minimum

2.0 SAFETY INFORMATION

2.1 USAGE AND SAFETY INFORMATION

To insure safe operations please read the following statements and understand their meaning. Also refer to your equipment manufacturer's manual for other important safety information. This manual contains safety precautions which are explained below. Please read carefully.



WARNING! — Warning is used to indicate the presence of a hazard that **can cause severe personal injury, death, or substantial property damage** if the warning notice is ignored.

CAUTION! — Caution is used to indicate the presence of a hazard that **will or can cause minor personal injury or property damage** if the caution notice is ignored.

2.2 PRODUCT SAFETY

Make sure all personnel involved with this jack read and understand these instructions before using.

WARNING!



The jack is designed to lift only vertical loads with a maximum weight of 50 ton (45.4 metric ton). Do not use jack for lifts exceeding the weight or design limits. Failure to comply can result in injury or death to personnel and/or severe damage to the jack and aircraft.

3.0 PREPARATION PRIOR TO FIRST USE

3.1 GENERAL INSPECTION

If the jack is crated, uncrate and remove shipping straps or packing material. Inspect for physical damage and missing parts.

3.2 BLEED PROCEDURE

1. Loosen hydraulic line at base of cylinder.
2. Raise cover assembly off cylinder.
3. Operate hand pump and air pump until oil comes out freely with no air bubbles. Tighten hydraulic line at base of cylinder.
4. Using hand pump or air pump, cycle cylinder rams several times.
5. Replace cover assembly on cylinder.

4.0 TRAINING

4.1 TRAINING REQUIREMENTS

The employer of the operator is responsible for providing a training program sufficient for the safe operation of the unit.

4.2 TRAINING PROGRAM

The employer provided operator training program should cover safety procedures concerning use of the unit in and around the intended aircraft at the intended aircraft servicing location.

4.3 OPERATOR TRAINING

The operator training should provide the required training for safe operation of the unit.

NOTE: Maintenance and Trouble Shooting are to be performed by a skilled and trained technician.

5.0 OPERATION

5.1 PRE-OPERATION PROCEDURE

1. Perform visual inspection, by checking for oil leakage.
2. Check for loose, damaged or missing parts.
3. Check oil level.

5.2 LIFTING PROCEDURE

1. Verify jack is located per airplane jacking procedures.
2. Release lowering handle from stowage hook to lower cylinder to ground.
3. Raise extension screw to mate with airplane axle jacking point.
4. Close release valve.
5. Connect air supply.
6. Activate the air pump.



CAUTION!

With no load applied to the jack, it is normal for either stage to extend first. Once a load is applied to the jack, ensure that the first stage ram (largest) is fully extended before the second stage ram (smallest) begins to extend. If the jack does not extend in this sequence, the jack should be disassembled to determine the cause of the excessive friction in the ram stages.

5.3 LOWERING PROCEDURE

1. Slowly open release valve to lower rams. Load must be lowered at a slow, constant rate or restrictor valve will activate.

NOTE: This jack is supplied with a restrictor valve as a safety feature. The restrictor valve senses the pressure of hydraulic oil and will lock and prevent the cylinder from retracting if there is a sudden loss of hydraulic pressure. To reset restrictor valve, pump jack to raise rams. Once the rams move, the restrictor valve will automatically reset.

2. When airplane tires are on ground, open release valve completely.
3. Activate the hand valve to fully retract rams.
4. Lower extension screw fully and disconnect the air supply.
5. Return lowering handle to latched position under stowage hook.
6. Remove jack from under airplane.
7. Place cover assembly over cylinder.

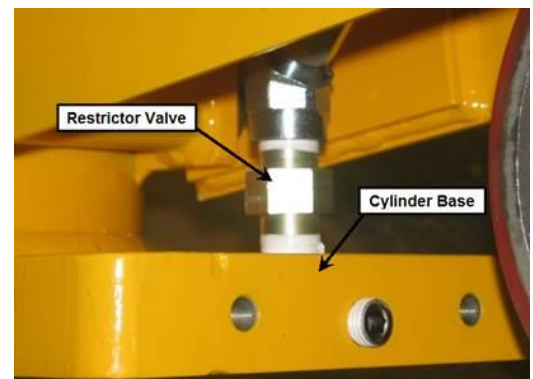

5.4 RELIEF VALVE SETTING

1. Position jack under a jack tester. Fully extend the first ram and partially extended the second stage ram.
2. Loosen nut on relief valve.
3. Operate air pump and verify that relief valve is set at 52.5 – 55 tons. Increase pressure setting by using an Allen wrench to adjust screw clockwise. To decrease pressure setting, adjust relief screw counterclockwise.



CAUTION!

**Use care not to set valve more than 10% above rated capacity.
DO NOT exceed 55 tons (79.9 metric tons).**

4. Tighten nut on relief valve.

6.0 TROUBLE SHOOTING

If operational troubles are encountered, refer to the Trouble Shooting Chart which lists the most commonly occurring problems and gives information which will facilitate location of trouble source and determination of remedial action.

TROUBLE	PROBABLE CAUSE	REMEDY
External fluid leakage at pump piston or pump body	Damaged backup ring, packing, piston or pump body	Remove affected piston and inspect piston and pump body for damage. Replace defective parts. Replace removed packing and backup ring
External fluid leakage at rams	Damaged backup ring, packing or inner cylinder wall	Withdraw rams as a unit from cylinder. Inspect defective parts. Replace o-ring
		Withdraw screw extension and ram components as a unit from cylinder. Inspect defective parts. Replace o-ring
Jack fails to lift rated load with operation of manual pump	Incomplete closure of release valve	Fully tighten release valve
	Obstructed fluid suction passages	Remove pump rocker and link details. Unscrew pump body; remove assembled valve assembly. Blow passage clear with compressed air; flush with clean fluid, reassemble and fill with hydraulic fluid
	Low fluid level	Fill to correct fluid level
	By-pass valve improperly adjusted	Test and adjust by-pass valve
	Broken compression spring	Remove pump rocker and link details, unscrew pump body. Remove and replace defective valve assembly; test and adjust by-pass valve
	Air lock or vacuum in reservoir, due to clogged breather passage in air vent; clogged intake oil screen	Remove air vent assembly and/or oil screen and clear the obstruction
Rams will not fully elevate when manual pump is operated	Low fluid level	Fill to correct fluid level
	Leaking pump discharge valve or leaking pump suction valve	Remove pump rocker and link details, unscrew pump body. Remove and replace defective valve assembly; test and adjust by-pass valve
Rams will not support load after manual pump up	Internal pressure leakage at ram static or dynamic seals	Check for external leakage. If present, replace defective seal. If no external leakage is observed then remove screw extension and check for oil inside of chamber. Oil here can be from a weld leak or leakage by the 1/8" pipe plug or the side of the housing
	Leaking pump discharge valve	Remove the check valve and verify holding capacity on test stand. If leakage occurs, replace
	Pressure leakage past release valve ball	Remove release valve, inspect ball and ball seat in pump block. Replace defective parts
Rams elevate and fall with each manual pump stroke	Incomplete closure of release valve	Fully tighten release valve
	Check valve next to cylinder and in hand pump, both are defective	Remove and replace defective check valve
	Pressure leakage past release valve ball	Remove release valve. Inspect ball and ball seat in pump block. Replace defective parts
Manual pump inoperative or difficult to operate	Air lock or vacuum in reservoir due to clogged breather passage in air vent assembly, clogged intake oil screen	Remove air vent assembly, and/or oil screen and clear obstruction
Pump-up satisfactory, but pump pressure fails to by-pass at maximum ram extension or with overload applied	By-pass valve improperly adjusted	Test and adjust by-pass valve
	Defective or jammed by-pass valve spring, rivet or ball	Remove pump rocker and link details, unscrew pump body. Remove and replace defective valve assembly. Test and adjust by-pass valve
Rams will not lower or fully retract and appear to be locked in place	Release valve opened too quickly and restrictor valve activated	Reset restrictor valve by closing release valve and pump jack until rams raise. Lower load by slowly opening release valve and lowering load at a slow, constant rate
	Sudden pressure drop in hydraulic system due to failed hose or other hydraulic component	Inspect jack for failed component and replace.

7.0 MAINTENANCE

7.1 SPECIAL MAINTENANCE INSTRUCTIONS

There are no special maintenance instructions for this jack

7.2 SHOP AIDS AVAILABLE

Bushing Spanner Wrench 8475-1001
Stop Nut Spanner Wrench 8438-1001
Ram Removal Tool 9380-1

7.3 OVERHAUL KITS AVAILABLE

Soft Kit KC2150-8.5
Repair Kit KC2150-8.5

8.0 PROVISION OF SPARES

8.1 SOURCE OF SPARE PARTS

Spare parts may be obtained from the manufacturer:

ColumbusJack/Regent
1 Air Cargo Pkwy East
Swanton, Ohio 43558 USA

Telephone: 614.443.7492
Fax: 614.444.9337
E-mail: sales@columbusjack.com
Website: www.columbusjack.com

8.2 RECOMMENDED SPARE PARTS LISTS

Reference the following page(s) for Replacement Parts and Kits available.

9.0 IN SERVICE SUPPORT

Contact Columbus Jack. for technical services and information. See Section 1.3 – Manufacturer.

10.0 GUARANTEES/LIMITATION OF LIABILITY

1. ColumbusJACK Corporation, (Seller) warrants each new product of its manufacture to be free from defects in material or workmanship, under proper, reasonable and normal use and service, and for a period of twelve (12) months after date of shipment from Seller's Swanton, OH. USA facility.
2. Where Buyer claims an alleged defect in material or workmanship and so advises Seller in writing within ten (10) days after discovery thereof, then and in such event, Buyer shall return said equipment, transportation prepaid, to the Seller, provided such return is timely and within twelve (12) months form date of original shipment. This warranty and liability of the Seller is expressly limited solely to replacement of repair of defective parts or goods, and return at Buyer's expense to Seller after find by Seller the product was defective prior to original shipment or, at the option of Seller, to making refund to Buyer of the purchase price for said product.
3. It is further expressly understood and agreed that:
 - a. THERE IS NO WARRANTY, representation of condition OF ANY KIND, express or implied, (INCLUDING NO WARRANTY OF MERCHANT-ABILITY OR OF FITNESS) EXCEPT THAT THE MATERIAL SHALL BE OF THE QUALITY SPECIFIED HEREIN, and none shall be implied by law. Except as otherwise provided herein, quality shall be in accordance with seller's specifications. Final determination of the material for the use contemplated by Buyer is the sole responsibility of Buyer and Seller shall have no responsibility in connection with such suitability, and
 - b. The Buyer's sole and exclusive remedy shall be repair or replacement of defective parts by the Seller. Should the goods, in the judgment of Seller, preclude the remedying of the warranted defects by repair or replacement, the buyer's sole and exclusive remedy shall be the refund of the purchase price, and
 - c. Seller shall not be liable for prospective profits or special, indirect or consequential damages, nor shall any recovery of any kind against Seller be greater in amount than the purchase price of the specific material sold and causing the alleged loss, damage or injury. Buyer assumes all risk and liability for loss, damage or injury to persons or property of Buyer or others arising out of use or possession of any product or part sold hereunder, and
 - d. The Seller shall in no way be deemed or held to be obligated, liable or accountable upon or for any guarantees or warranties, express or implied, or created by statute or by operation of law or otherwise, in any manner of form beyond its express agreement above set forth, and
 - e. No warranty herein shall apply to any product which shall have been repaired or altered, unless such alteration or repair has been made by Seller or where, after return to and inspection by Seller, the product is found by Seller to have been subject to misuse, negligence or accident, and
 - f. No warranty of any nature is made by Seller as to any component forming a part of the product sold and Buyer shall receive only such warranties offered by such other manufacturer pertinent to such component, and
 - g. Seller does not assume nor does Seller authorize any other person to assume for it any other liability or make any warranty in connection with the sale of its products.

The obligations of ColumbusJACK expressly stated herein are in lieu of all other warranties or conditions expressed or implied. **Any unauthorized modification of the ColumbusJACK products or use of the ColumbusJACK products in violations of cautions and warnings in any manual (including updates) or safety bulletins published or delivered by ColumbusJACK will immediately void any warranty, express or implied and ColumbusJACK disclaims any and all liability for injury (WITHOUT LIMITATION and including DEATH), loss or damage arising from or relating to such misuse.**

11.0 APPENDICES

APPENDIX I Routine Jack Maintenance Bulletins

This page left blank intentionally.

Parts List

When ordering replacement parts/kits, please specify model, serial number and color of your unit.

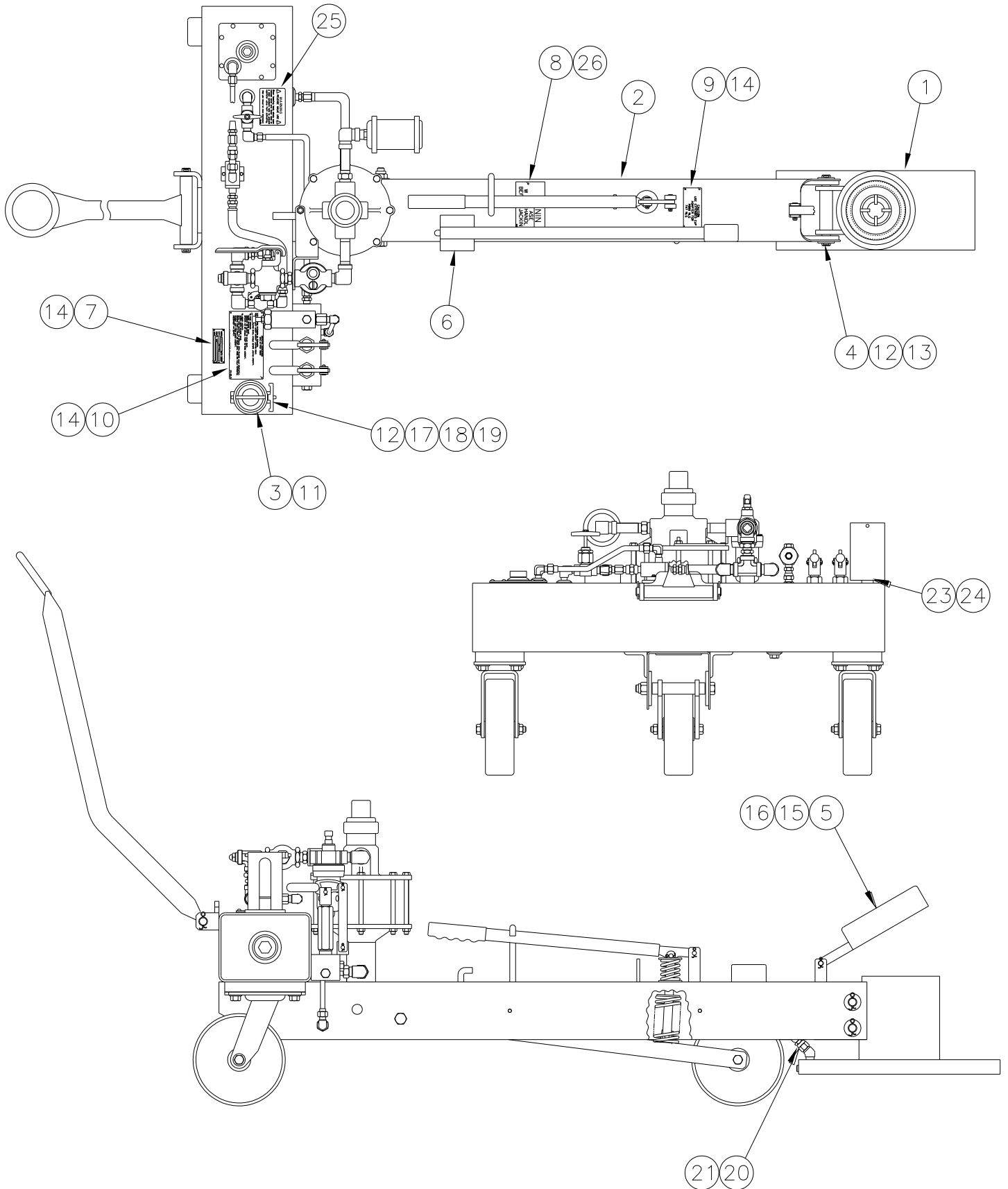

Parts List

When ordering replacement parts/kits, please specify model, serial number and color of your unit.

Item	Part Number	Description	Qty
1	9438-C	Cylinder Assembly	1
2	1158-1400	Frame Assembly	1
3	916-488	Holder Weldment	1
4	9331-15	Cylinder Pin	2
5	9386-10	Rain Hat Assembly	1
6	915-143U	Pump Handle	1
7	915-176	Nameplate	1
8	915-521	Warning Placard	1
9	915-523	Cup Adapter Placard	1
10	915-635	Operation Placard	1
11	916-257	Extended Adapter	1
12	322-04400	Cotter Pin	4
13	AN960-1216L	Flat Washer	4
14	450A6984	Drive Screw	12
15	321-14410	Clevis Pin	1
16	322-03240	Cotter Pin	1
17	450A5895	Ball Lock Pin	1
18	450A5385	Wire Rope	1
19	450A5715	Oval Sleeve	1
20	915-HD	Restriction Valve	1
21	450A6105	Elbow	1
23	372-20070	Hex Head Cap Screw	1
24	346-10032	Lockwasher	1
25	160-690	Warning Label	1
26	450A6989	Drive Screw	2

Parts List

When ordering replacement parts/kits, please specify model, serial number and color of your unit.

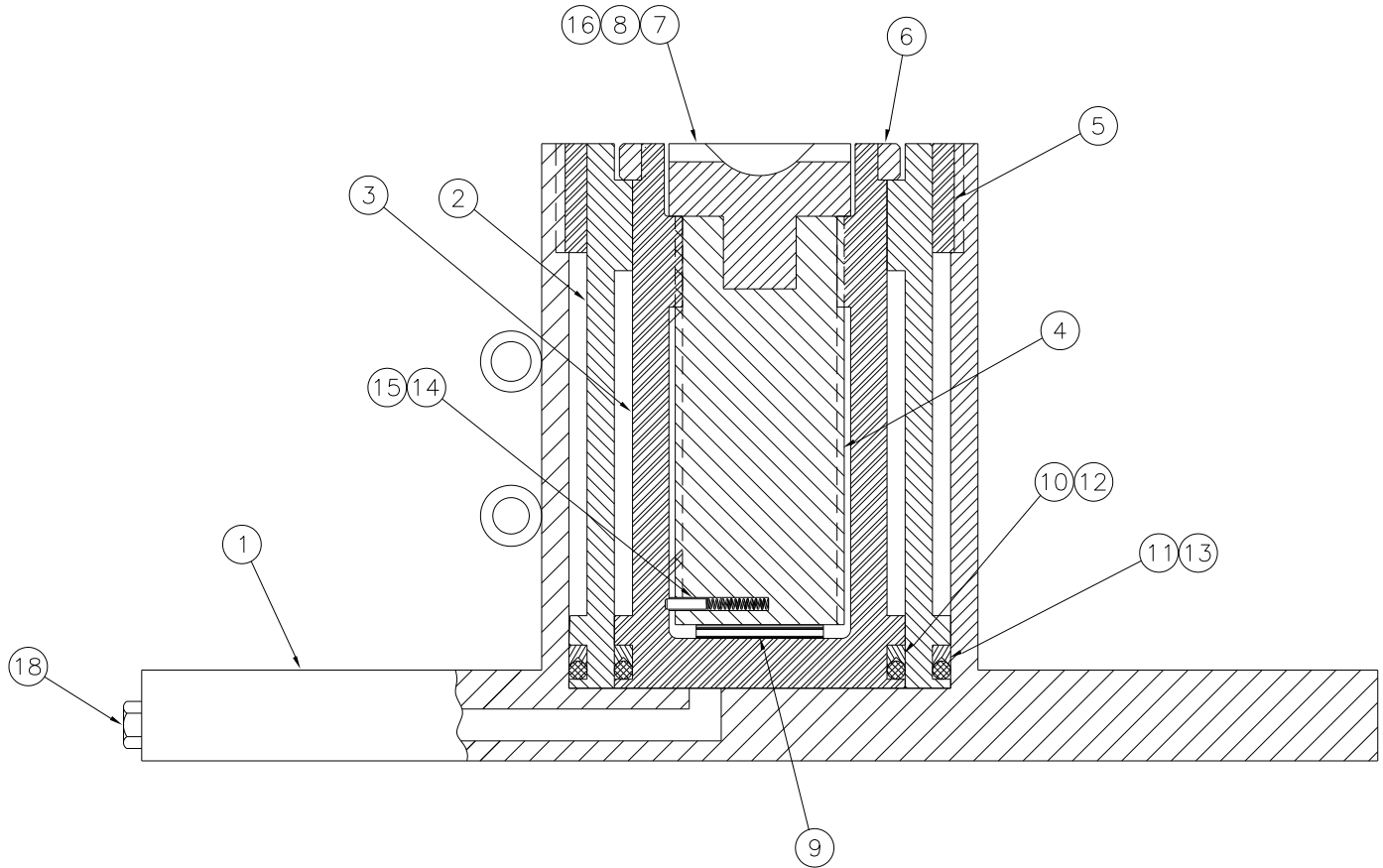

Item	Part Number	Description	Qty
	9438-C	Cylinder Assembly ; consists of:	
1	9438-1	Cylinder Weldment	1
2	9438-2	Ram, First Stage	1
3	9438-3	Ram, Second Stage	1
4	9475-4	Screw Extension	1
5	9438-5	Bushing	1
6	9438-8	Stop Nut	1
7	312-12020	Set Screw, Cup Point	1
8	916-310	Cup Adapter	1
9	9475-52	Pad	1
10	916-45-3.568	Backup Ring	1
11	916-44-4.684	Backup Ring	1
12	611-34134	O-Ring	1
13	611-42742	O-Ring	1
14	916-197	Stop Pin	1
15	1946-17	Spring	1
16	312-20041	Set Screw, Flat Point	1
18	488-00004	Pipe Plug	1

Parts List

When ordering replacement parts/kits, please specify model, serial number and color of your unit.

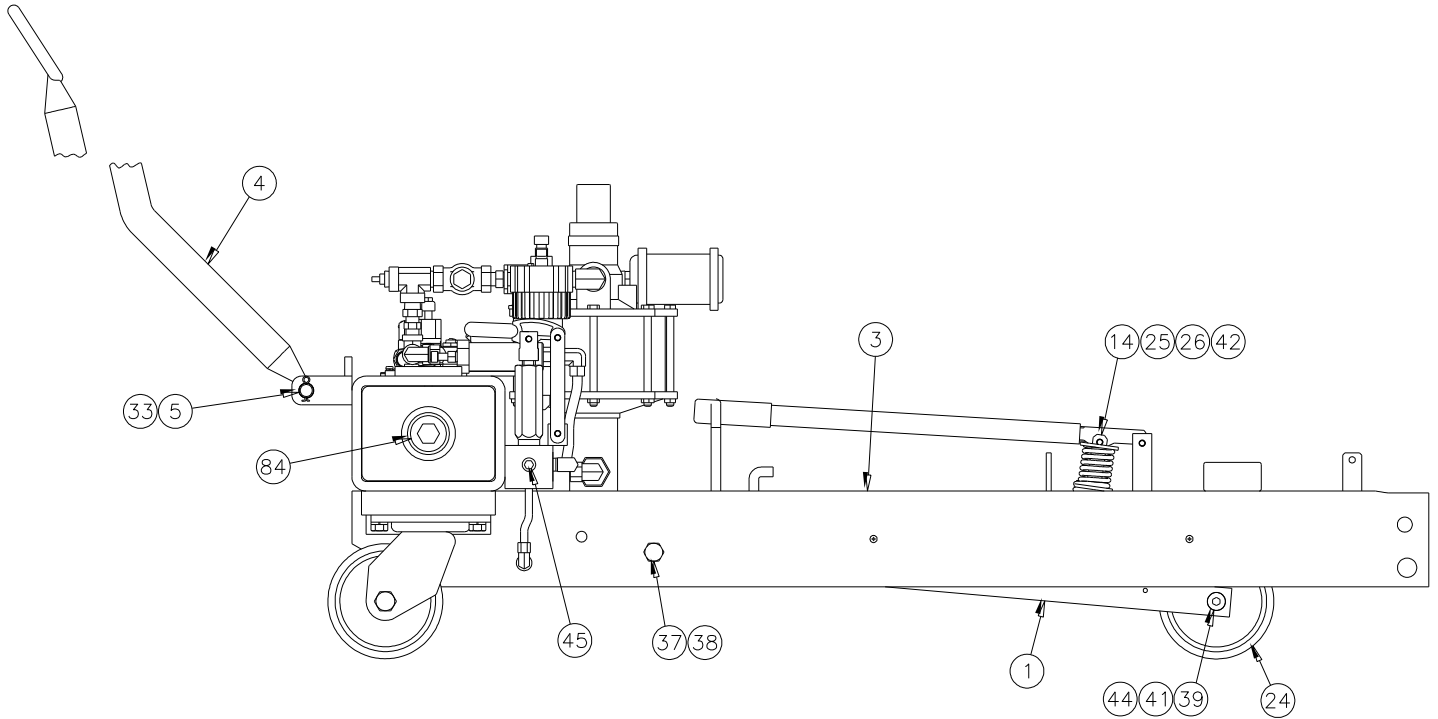

Item	Part Number	Description	Qty
	1158-1400	Frame Assembly ; consists of:	
1	9385-9	Wheel Bracket	1
3	1158-1140	Frame Weldment	1
4	1905-19	Towbar	1
5	1905-20	Pivot Pin	1
14	9385-151	Link	2
24	450A5535	Wheel	1
25	450A6036	Compression Spring	1
26	450A6195	Spring	1
33	322-04400	Cotter Pin	6
37	333-32410	Hex Jam Locknut	1
38	372-24480	Hex Head Cap Screw	1
39	333-32010	Hex Jam Locknut	1
41	9563-50	Flat Head Screw	1
42	345-10064	Flat Washer	3
44	346-10032	Lockwasher	9
45	488-00006	Pipe Plug	1
84	488-00024	Pipe Plug	1

Parts List

When ordering replacement parts/kits, please specify model, serial number and color of your unit.

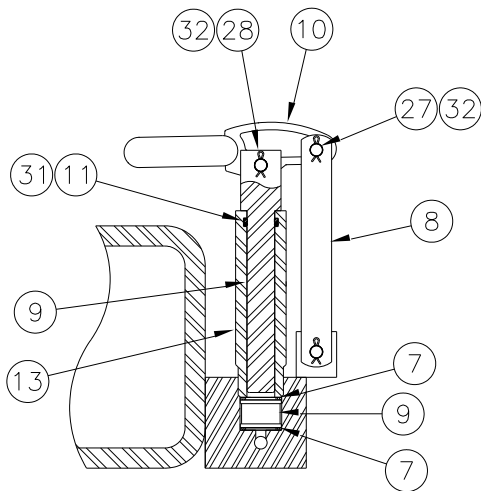
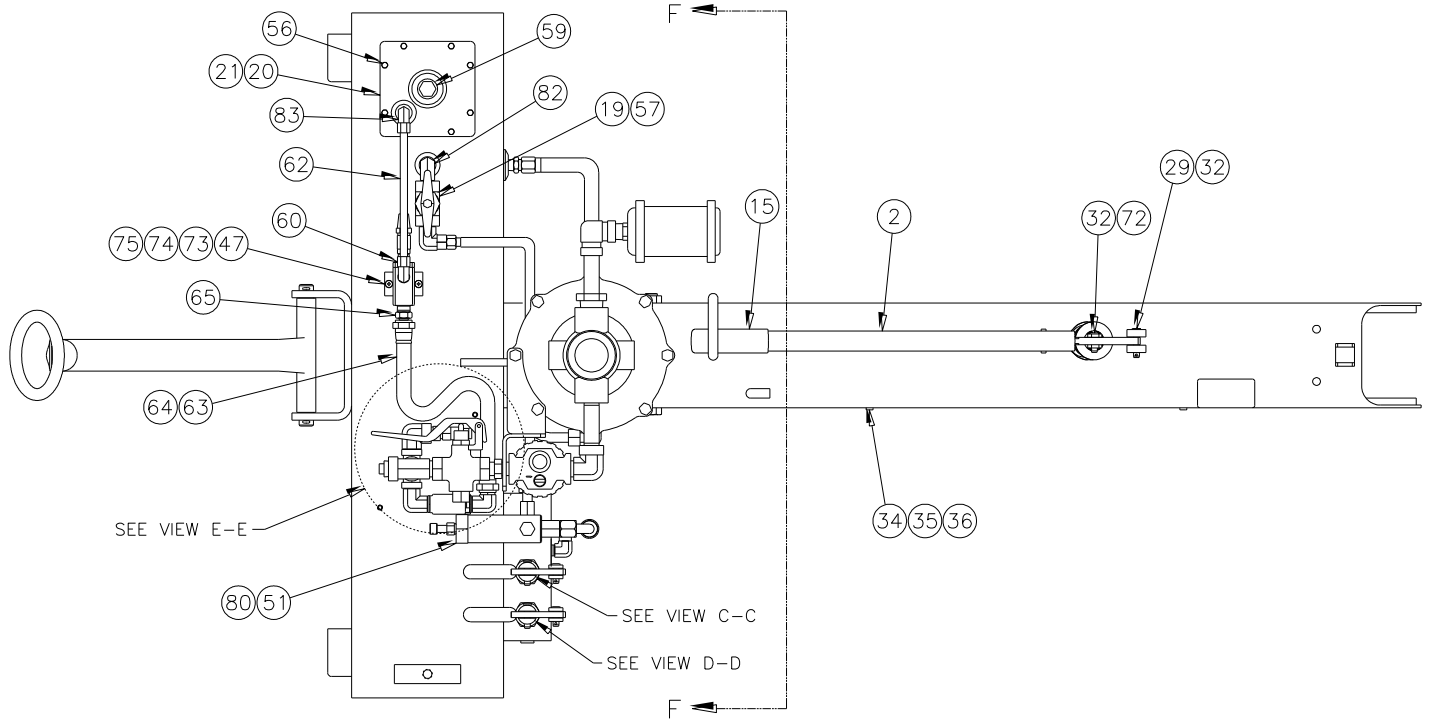

VIEW C-C
SCALE: 2/1

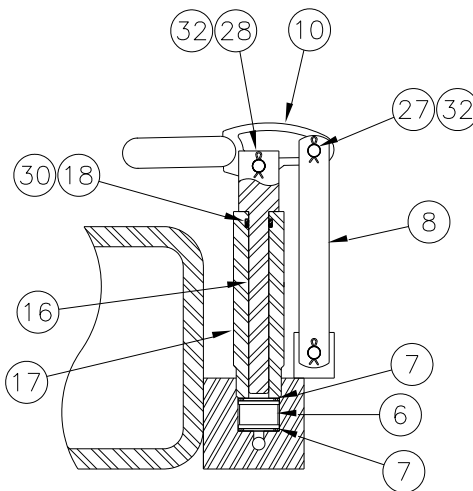

VIEW D-D
SCALE: 2/1

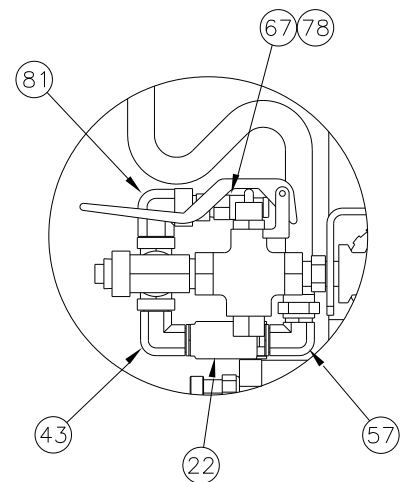

VIEW E-E
SCALE: 1.5/1

Parts List

When ordering replacement parts/kits, please specify model, serial number and color of your unit.

Item	Part Number	Description	Qty
	1158-1400	Frame Assembly ; consists of:	
2	9385-14	Lowering Handle	1
6	915-16A-S	Valve	2
7	915-17	Gasket	4
8	915-151.40	Link	2
9	915-74C	Piston	1
10	915-75	Rocker Arm	2
11	915-127.13	Backup Ring	1
13	915-179	Pump Body	1
15	915-BSB-33	Grip	1
16	915-138C	Piston	1
17	915-244	Pump Body	1
18	915-127.10	Backup Ring	1
19	450A3221	Valve	1
20	9331-33	Access Plate	1
21	9139-13	Gasket	1
22	450A3202	Hand Valve	1
29	321-14410	Clevis Pin	1
27	321-14250	Clevis Pin	4
28	321-14330	Clevis Pin	2
30	611-11211	O-Ring	1
31	611-11511	O-Ring	1
32	322-03240	Cotter Pin	10
34	333-31000	Hex Locknut	2
35	316-10050	Pan Head Screw	2
36	450A7117	Clamp Loop, (Cushioned)	2
43	483-00606	Male Pipe Elbow	1
47	SC-284	Vacuum Pump	1
51	915-HM	Relief Valve	1
56	372-10040	Hex Head Cap Screw	8
57	456-10606	Male Elbow	3
59	488-00012	Pipe Nipple	1
60	456-10602-A	Male Elbow	1
62	SST-13849	Tube, Stainless	A/R
63	450A5963	Female Connector	2
64	450A5744	Hose Assembly	1
65	457-10602	Male Connector	1
67	450A6198	Relief Valve	1
72	321-14280	Clevis Pin	2
73	372-10040	Hex Head Cap Screw	2
74	345-11010	Flat Washer	2
75	346-10010	Lockwasher	2
78	485-50604	Pipe Thread Reducer	1
80	457-10606	Male Connector	1
81	485-00606	Street Elbow	1
82	915-625	Return Line Elbow	1
83	456-10604-A	Male Elbow	1

Parts List

When ordering replacement parts/kits, please specify model, serial number and color of your unit.

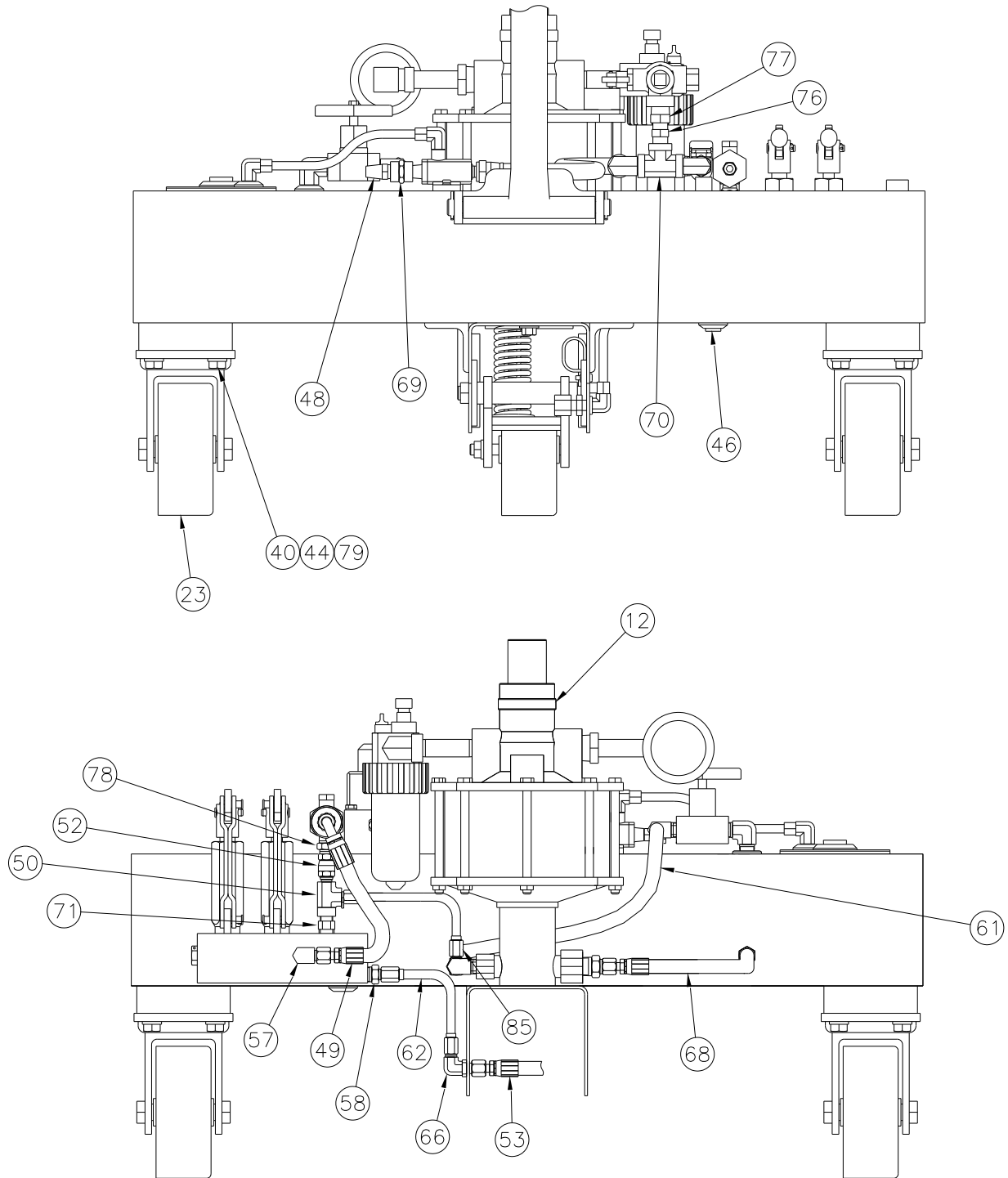

VIEW F-F
SOME ITEMS REMOVED FOR CLARITY

Parts List

When ordering replacement parts/kits, please specify model, serial number and color of your unit.

Item	Part Number	Description	Qty
	1158-1400	Frame Assembly ; consists of:	
12	1158-1800	Air Pump Assembly	1
23	450A5993	Caster, Swivel	2
40	372-20180	Hex Head Cap Screw	8
44	346-10032	Lockwasher	9
46	488-10006	Pipe Plug	1
48	450A5960	Air Muffler	1
49	1158-1604	Hose Assembly	1
50	463-10604	Female Run Tee	1
52	475-20604	Swivel Connector	1
53	1158-1601	Hose Assembly	1
57	456-10606	Male Elbow	3
58	457-10606-A	Male Connector	1
61	1158-1603	Hose Assembly	1
62	SST-13849	Tube, Stainless	A/R
66	482-00606-AL	Bulkhead Union Elbow	1
68	1158-1602	Hose Assembly	1
69	484-20404	Pipe Coupling	1
70	484-40606	Female Pipe Tee	1
71	483-10604	Pipe Nipple	1
76	483-10606	Pipe Nipple	1
77	485-50806	Pipe Thread Reducer	1
78	485-50604	Pipe Thread Reducer	1
79	9475-60	Spacer	2
85	467-10606-A	Swivel Nut Run Tee	1

Parts List

When ordering replacement parts/kits, please specify model, serial number and color of your unit.

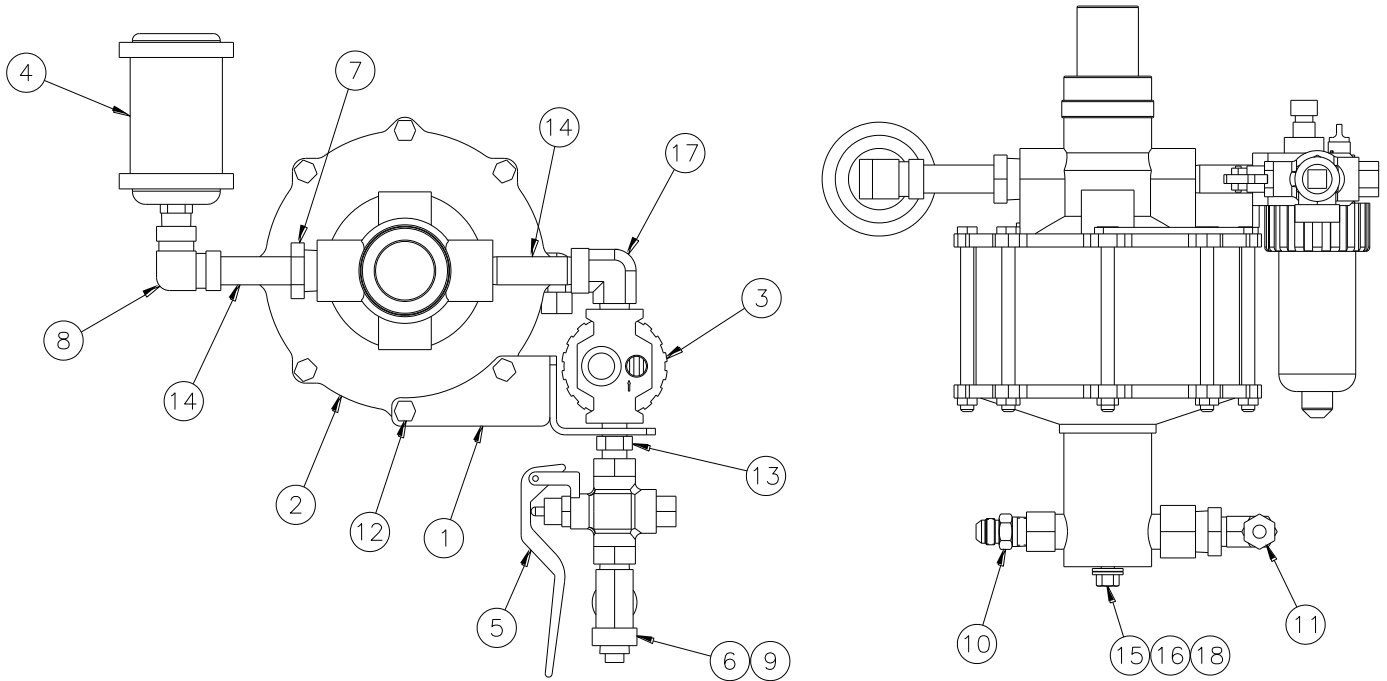

Item	Part Number	Description	Qty
	1158-1800	Air Pump Assembly; consists of:	
1	9355-29	Support Bracket	1
2	450A7262	Air Pump	1
3	450A5498	Lubricator	1
4	450A5500	Muffler	1
5	450A5529	Squeeze Valve	1
6	450A5502	Plug	1
7	485-51608	Pipe Thread Reducer	1
8	484-00808	Female Pipe Elbow	1
9	485-40808	Male Run Tee	1
10	457-10806-A	Male Connector	1
11	456-10606-A	Male Elbow	1
12	371-16204	Hex Head Cap Screw	2
13	483-10808	Pipe Nipple	1
14	483-20848	Pipe Nipple	2
15	345-11024	Flat Washer	2
16	372-16100	Hex Head Cap Screw	2
17	485-00808	Street Elbow	1
18	346-10024	Lockwasher	1



APPENDIX I

Routine Jack Maintenance Bulletins



Routine Jack Maintenance Bulletin

TO PROVIDE COMPLETE INFORMATION ON SERVICING
ColumbusJACK/REGENT QUALITY GROUND HANDLING EQUIPMENT

BULLETIN RJM 102 – PROCEDURE FOR WINTERIZATION OF HYDRAULIC AIRCRAFT JACKS

The following procedures should be utilized for optimum operational characteristics when using jacks at various temperature extremes:

1. Above 0°F (-18°C) Use MIL-PRF-5606, or equal, with no further additive required.
2. At 0° to -20°F (-18°C to 29°C) Use a mixture of 75% MIL-PRF-5606, or equal, and 25% kerosene.
3. Below -20°F (-29°C) Use a mixture of 50% MIL-PRF-5606, or equal, and 50% kerosene.

Due to most company, safety, or union regulations which restrict employees from working out-of-doors below -30°F (-34°C), there is a lack of experience beyond this point. It is permissible, however, to increase the percentage of kerosene up to 100%. As the ambient temperature increases, MIL-PRF-5606, should be added back to the system in the appropriate mixture.

The air supply should be clean and dry. At -30°F (-34°C), the air pump will start to react sluggishly and continue to operate less efficiently as the temperature decreases when a normal air supply is used. The problem can be eliminated by using a dry nitrogen source of sufficient capacity.

To ease the operation of the locknut(s) and screw extension, use "Never Freeze" by Snap-On, or equal, and apply liberally to the thread surfaces.



Routine Jack Maintenance Bulletin

TO PROVIDE COMPLETE INFORMATION ON SERVICING
ColumbusJACK/REGENT QUALITY GROUND HANDLING EQUIPMENT

BULLETIN RJM 116 – SCREW EXTENSION USAGE

When using a jack that has a screw extension, it is advisable that the screw extension be extended as far as possible, and still have the jack roll under the jacking point. If the screw extension is not properly extended, the aircraft may not be able to be raised to the desired height.

A periodic check should be made to the screw extension to ensure that the stop is operating properly to prevent over-extension. To do this, rotate the screw extension counterclockwise until it stops rotating. **DO NOT FORCE THE SCREW EXTENSION BEYOND THIS POINT.** If the screw extension does not stop rotating, remove it and repair the stop. **DO NOT USE WITHOUT THE SCREW EXTENSION STOP WORKING PROPERLY, AS THE JACK COULD FAIL WITH AN OVER-EXTENDED SCREW EXTENSION.**

BULLETIN RJM 147 – RECOMMENDED ANNUAL JACK CERTIFICATION PROCEDURE

The following Recommended Annual Jack Certification Procedure is provided as a guide to insure that hydraulic aircraft jacks are always certified for operation. An annual time interval is a general recommendation only. The actual interval used should include factors for the climatic conditions in which the equipment is stored and the frequency of equipment use. Recommendations for Suggested Preventative Maintenance can be found in RJM 170.

1. With no external load applied to the jack, fully close release valve and fully extend ram(s) to verify function and the absence of external hydraulic leakage.



WARNING!

DO NOT APPLY PRESSURE AGAINST INTERNAL RAM STOP(S).

2. Open release valve and verify ram(s) retract fully.
3. Position jack under jack tester.

NOTE: For tripod jacks, all leg extensions should be installed on the jack.

4. Close release valve, and extend ram(s) until cup adapter contacts jack tester. Make sure that the ram of a single stage jack is partially extended and that the smaller ram of a multi-stage jack is partially extended.
5. Pressurize the jack against the jack tester. Using a calibrated pressure gauge on either the jack or the jack tester, monitor the pressure until the capacity (operating pressure) of the jack is reached.
6. With the jack pressurized against the jack tester, hold in this position for 3 minutes. Verify that the jack pressure has not decreased, indicating internal leakage.
7. Open the release valve to relieve jack pressure against the jack tester.
8. Set the safety relief valve per jack operation and maintenance manual.

BULLETIN RJM 149 – TEFLON BACKUP RING INSTALLATION PROCEDURE

When installing new Teflon backup rings on a ram or piston of any jack model, the following procedure should be observed to ensure correct installation of the ring. When installing a new backup ring, the corresponding o-ring should always be replaced also.

1. Cut existing o-ring and Teflon backup ring.
2. Clean and visually inspect the groove in the ram or piston for any nicks, scratches or score marks, which could cut the o-ring and backup ring during installation.
3. Check to ensure backup ring is clean and not damaged.
4. Set backup ring on a flat metal surface.
5. Using a propane torch, heat backup ring in a circular motion until backup ring is equally softened and pliable or flexible.
6. Carefully pick-up the **HOT** Teflon backup ring off the **HOT** metal plate and stretch the ring enough to fit over the end of the ram (piston).

NOTE: Make sure the "V" cup portion of the backup ring will face the o-ring.
(See figure)

7. If backup ring does not return to size after cooling, re-heat backup ring while on the part, and cool quickly with a cold, wet towel or rag.
8. Check to ensure o-ring is clean and not damaged.
9. Carefully stretch o-ring over the end of the ram (piston). Ensure that the o-ring and the "V" cup of the backup ring are facing each other. (See figure)

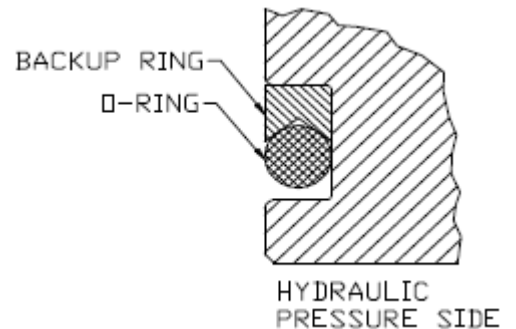



Routine Jack Maintenance Bulletin

TO PROVIDE COMPLETE INFORMATION ON SERVICING
ColumbusJACK/REGENT QUALITY GROUND HANDLING EQUIPMENT

BULLETIN RJM 170 – SUGGESTED PREVENTATIVE MAINTENANCE FOR JACKS

The following Preventative Maintenance Schedule is provided as a guide to insure that hydraulic aircraft jacks are always ready for operation. The time intervals listed are a general recommendation only. The actual interval used should include factors for the climatic conditions in which the equipment is stored and the frequency of equipment use.

Prior to Operation

1. Inspect for damaged or missing components.
2. Inspect for oil leakage and proper fluid level.
3. Inspect screw extension for mechanical stop.
4. Inspect all snap rings for engagement into grooves.
5. Inspect jack adapter for damage.

Every 6 Months

1. Inspect for worn snap ring grooves.
2. Change hydraulic filters if applicable.
3. If jack has not been used regularly, cycle jack without load.
4. Grease all lube fittings with a general purpose grease.
5. Wipe down ram(s) and screw extension with hydraulic oil.

Every 12 Months

1. Calibrate pressure gauge if applicable per RJM 173.
1. Perform "Recommended Annual Jack Certification Procedure" per RJM 147.



Routine Jack Maintenance Bulletin

TO PROVIDE COMPLETE INFORMATION ON SERVICING
ColumbusJACK/REGENT QUALITY GROUND HANDLING EQUIPMENT

BULLETIN RJM 171 – RECOMMENDED HYDRAULIC OILS

The following hydraulic oils are recommended for use in all ColumbusJACK/Regent products, though any oil compatible with Buna-N seals may be used. Proper oil level should be .5 to 1 inch below the fill port when all rams are collapsed.

Exxon/Mobil Aero HF (MIL-PRF-5606)
Exxon/Mobil DTE-11, -15
NATO Code No. H-538 (MIL-PRF-87257)
Phillips 66 X/C 5606
Royco 783 (Anderol) (MIL-PRF-6083)
Royco 782 (Anderol) (MIL-PRF-83282)
Shell Tellus 10, 15
Shell Aerofluid 31 (MIL-PRF-83282)
Shell Aerofluid 41 (MIL-PRF-5606)
Texaco Regal Oil R & O (32, 46, 100, 150, 220, 320, 460)