



OPERATION & SERVICE MANUAL

Model: 14-6886-6000 Aircraft Tire/Strut Service Gauge

09/2023 - Rev. 02

**For Spare Parts, Operations & Service Manuals or Service Needs
Scan the QR code or visit [Tronair.com/aftermarket](https://www.tronair.com/aftermarket)**



REVISION	DATE	TEXT AFFECTED
01	08/2009	Original release
02	09/2023	Added CE Mark and Declaration of Conformity

TABLE OF CONTENTS

	<u>PAGE</u>
1.0 DESCRIPTION	1
2.0 SAFETY INSTRUCTIONS	1
2.1 GENERAL	1
2.2 SAFETY	1
3.0 OPERATION OF NITROGEN STRUT SERVICE KIT	2
3.1 TRAINING	2
3.2 GENERAL SAFETY REQUIREMENTS	2
4.0 GUARANTEES/LIMITATION OF LIABILITY	2
5.0 APPENDICES	2

This product can not be modified without the written approval of Tronair, Inc. Any modifications done without written approval voids all warranties and releases Tronair, Inc., its suppliers, distributors, employees, or financial institutions from any liability from consequences that may occur. Only Tronair OEM replacement parts shall be used.

1.0 DESCRIPTION

HIGH PRESSURE REGULATOR

Type Single Stage
Gas..... Inert only NO OXYGEN
Delivery Range..... 100-4,500 psig
Maximum Inlet Pressure..... 5,500 psig
Inlet Connection CGA-680
Hose Length 15 ft
Outlet shut-off valve for controlled delivery
Outlet Connection..... Hi pressure STD strut valve (.305-32" thread size) without valve core depressor
Instrument not affected by moisture, condensation, or other corrosive environmental conditions
Unit is NOT Skydrol resistant

AIRCRAFT TIRE SERVICE GAUGE

Maximum Operating range 200 psi
Pressure Gauge
Range..... 0-200 psi
Gauge Dial Graduations 2 psi increments
Accuracy..... ± 1 ½ %full scale
Dial Size 2 ½ "
Temperature Range -40° to 150° F
Fill Fluid Glycerin
Lens Material..... Plexiglas
Sealed and filled case with rubber case protector for shock absorption
Liquid case offers increased reliability and extended calibration life
Certified gauge
Hose Length 16"
Inlet Connection Std air valve (.305-32" thread size) without valve core
Outlet Connection..... Dual foot tire valve (.305-32" thread size) without valve core depressor
Unit is designed for low pressure applications
Instrument not affected by moisture, condensation, or other corrosive environmental conditions
Unit is NOT Skydrol resistant

2.0 SAFETY INSTRUCTIONS



CAUTION!

It is MANDATORY that this instruction manual be read and understood by all persons operating this high pressure nitrogen strut service kit.

2.1 GENERAL

Information presented in this manual and on various labels, tags and plates on the unit pertains to equipment design, installation, operation, maintenance and trouble shooting which should be read, understood and followed for the safe and effective use of this equipment.

2.2 SAFETY

The operation, maintenance, and trouble shooting of this high pressure nitrogen strut service kit requires practices and procedures which ensure personal operator safety and the safety of others. Therefore, this equipment is to be operated and maintained only by qualified persons in accordance with this manual and all applicable local codes.

NOTE: Safety instructions specifically pertaining to this kit appear throughout this manual highlighted by the signal words: WARNING, CAUTION, which identify different levels of hazard.



WARNING! Denote practices which if not carefully followed, could result in serious personal injury and/or death.

CAUTION! Denote practices which if not carefully followed, could result in minor personal injury or damage to this equipment.

Nitrogen equipment must be kept clean and free from contaminants at all times. It is imperative that all inspection, maintenance, testing and servicing of nitrogen system components be done by trained and qualified personnel using approved procedures.

3.0 OPERATION OF NITROGEN STRUT SERVICE KIT



WARNING!

TO AVOID SERIOUS INJURY, LOSS OF LIMB, AND/OR DEATH:

1. **DO NOT** use high pressure nitrogen on aircraft components designed for low pressure nitrogen.
2. **DO NOT** use with oxygen or gas other than nitrogen.
3. **DO NOT** exceed 4,500 psi inlet pressure.
4. Servicing and maintenance of nitrogen systems shall be done by only trained and qualified personnel using approved procedures.

3.1 TRAINING

Read this entire manual prior to operation of the unit. All personnel using this Nitrogen Service Strut Kit should understand and follow this manual and receive training. We encourage our customers to call Tronair at 800-426-6301 to discuss any operating or testing requirements.

3.2 GENERAL SAFETY REQUIREMENTS

- A. Pressures:** Gasses under pressure are a potential hazard in the form of stored energy. Accidents can occur when this energy is improperly handled. Be sure that all equipment used is compatible and designed to control the pressures encountered.
- B. Nitrogen:** Nitrogen is chemically stable, non-flammable, and does not support combustion.
- C. Handling:** Nitrogen handling must be done with care. The rapid expansion of nitrogen gas from a high pressure source to an area of low pressure can produce cryogenic temperatures which could cause severe burns.



WARNING!

DO NOT use on low pressure nitrogen system or components.

If there are any differences between the following instructions and the aircraft maintenance manual, the aircraft maintenance manual will take precedence.

Be sure fill line is secured prior to purging the unit. This will prevent the nose end from whipping about if too much nitrogen is allowed to flow through the unit.



CAUTION!

Be sure all valves and controls are in the closed (OFF) position.

4.0 GUARANTEES/LIMITATION OF LIABILITY

Tronair products are warranted to be free of manufacturing or material defects for a period of one year after shipment to the original customer. This is solely limited to the repair or replacement of defective components. This warranty does not cover the following items:

- a) Parts required for normal maintenance
- b) Parts covered by a component manufacturers warranty
- c) Replacement parts have a 90-day warranty from date of shipment

If you have a problem that may require service, contact Tronair immediately. Do not attempt to repair or disassemble a product without first contacting Tronair, any action may affect warranty coverage. When you contact Tronair be prepared to provide the following information:

- a) Product Model Number
- b) Product Serial Number
- c) Description of the problem

If warranty coverage is approved, either replacement parts will be sent or the product will have to be returned to Tronair for repairs. If the product is to be returned, a Return Material Authorization (RMA) number will be issued for reference purposes on any shipping documents. Failure to obtain a RMA in advance of returning an item will result in a service fee. A decision on the extent of warranty coverage on returned products is reserved pending inspection at Tronair. Any shipments to Tronair must be shipped freight prepaid. Freight costs on shipments to customers will be paid by Tronair on any warranty claims only. Any unauthorized modification of the Tronair products or use of the Tronair products in violation of cautions and warnings in any manual (including updates) or safety bulletins published or delivered by Tronair will immediately void any warranty, express or implied.

The obligations of Tronair expressly stated herein are in lieu of all other warranties or conditions expressed or implied. **Any unauthorized modification of the Tronair products or use of the Tronair products in violations of cautions and warnings in any manual (including updates) or safety bulletins published or delivered by Tronair will immediately void any warranty, express or implied and Tronair disclaims any and all liability for injury (WITHOUT LIMITATION and including DEATH), loss or damage arising from or relating to such misuse.**

5.0 APPENDICES

APPENDIX I Instrument Certification Notice

Parts List - Aircraft Tire Pressure Gauge

When ordering replacement parts/kits, please specify model, serial number and color of your unit.

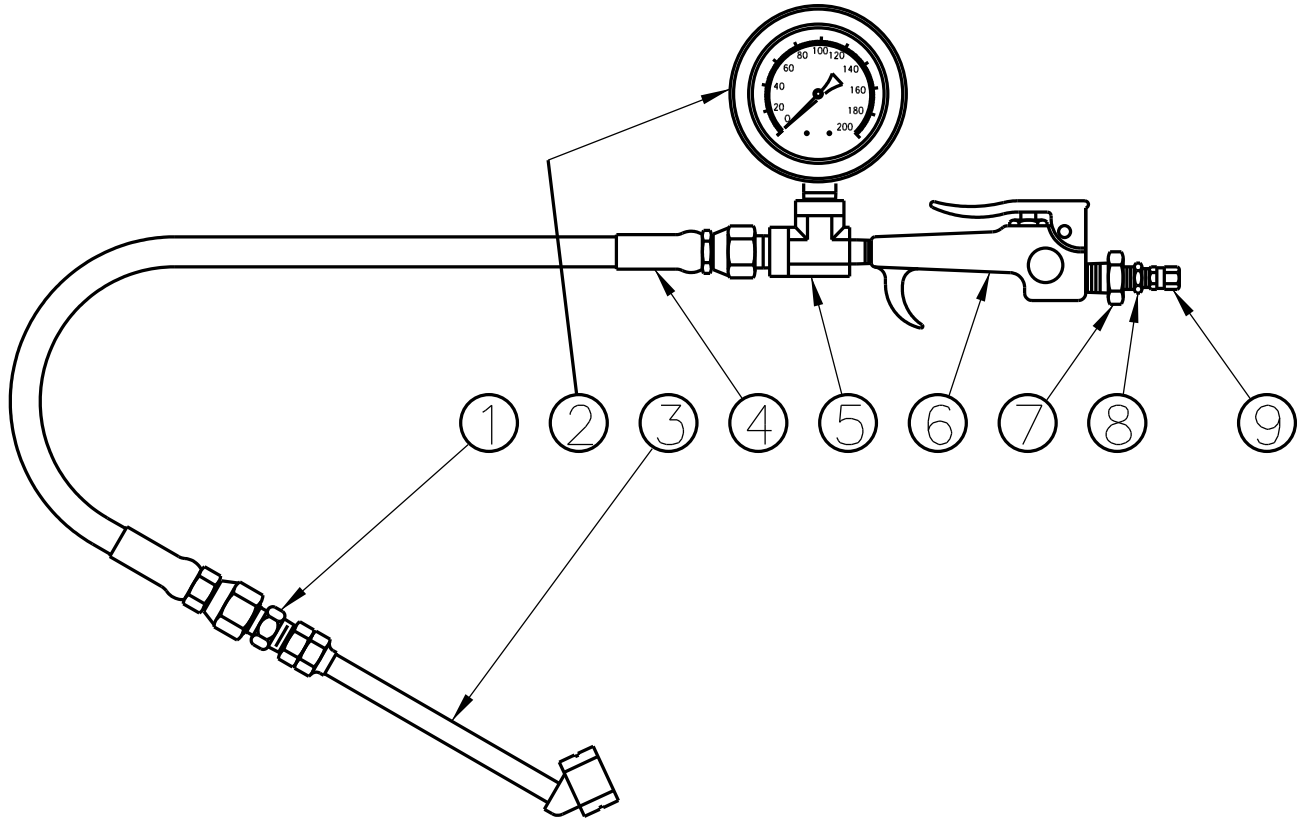

WARNING!



1. The maximum operating pressure for this gauge assembly is 200 psi (13.8 bar).
2. This gauge assembly is NOT Skydrol resistant.

GAUGE CALIBRATION: The pressure gauge is to be calibrated annually or as required. Reference Instrument Certification Notice.

Item	Part Number	Description	Qty
1	N-2009-08-S	Connector, Male	1
2	HC-1836	Gauge, Pressure 200 psi with ROP	1
3	H-2201	Chuck, Dual Foot Air Inflator	1
4	TF-1043-15*16.0	Assembly, Hose, 520N-4 x 16 Long	1
5	N-2209-27-S	Tee, Street	1
6	H-2158	Gun, Lever-Type Air Blow	1
7	N-2010-02-S	Reducer, Pipe Thread	1
8	PC-1073	Valve, High Pressure Strut	1
9	PC-1074	Cap, High Pressure Strut Valve	1

Parts List - High Pressure Regulator

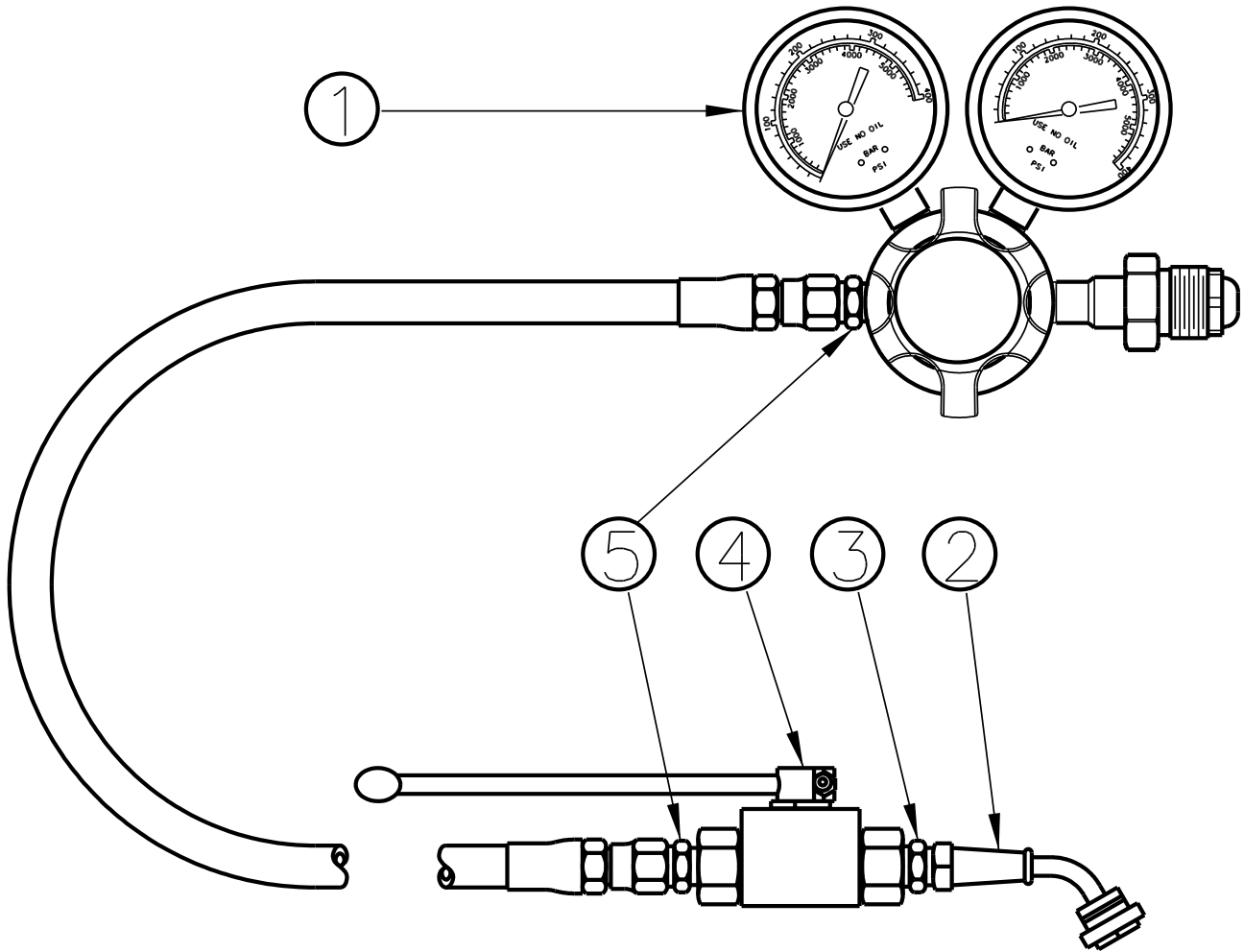

WARNING!



1. The maximum operating pressure for this assembly is 4500 psi (310 bar).
3. This gauge assembly is NOT Skydrol resistant.

GAUGE CALIBRATION: The pressure gauge is to be calibrated annually or as required. Reference Instrument Certification Notice.

Item	Part Number	Description	Qty
1	PC-1096	Regulator, High Pressure CGA-680	1
2	PC-1067	Coupling, High Pressure Hose	1
3	N-2203-03-S	Connector, Male	1
4	HC-1834-02	Valve, Ball	1
5	N-2009-04-S	Connector, Male	1
6	TF-1043-01*180	Assembly, Hose, ¼ x 180 Long	1

Note: replacement gauge only is Part Number 9006252



Instrument Certification Notice

The gauge Certificates of Calibration supplied for the gauge(s) on this unit contain the calibration data for the actual instrument calibrated, along with the calibration date of the **STANDARD** used to perform the calibration check.

The due date for re-calibration of the instrument should be based upon the date the instrument was placed in service in your facility. Re-calibration should be done on a periodic basis as dictated by the end user's quality system or other overriding requirements.

Note that Tronair, Inc. does not supply certificates of calibration on flow meters or pyrometers unless requested at the time of placed order. These instruments are considered reference indicators only and are not critical to the test(s) being performed on the aircraft.



STATEMENT OF COMPLIANCE

Tronair has assessed the equipment described below against the Requirements of the Directive listed below. Based on Article 4, Section 3 of the directive, the equipment shall not carry the CE mark.

This equipment has been designed and manufactured in accordance with Sound Engineering Practice.

This statement of compliance is issued under the sole responsibility of the manufacturer.

Model Number(s) 14-6886-6000

Product Type/Name: Aircraft Tire Pressure Gauge

Directive: Pressure Equipment Directive 2014/68/EU, Article 4: Section 3
Without prejudice to other applicable Union harmonization legislation providing for its affixing, such equipment or assemblies shall not bear the CE marking.

Identification of person empowered to sign on behalf of the Manufacturer:

A handwritten signature in cursive script that reads "Patrick Finch".