

**Model: 14-6906-0110
Strut Service Tool**



06/2015 – Rev. 02

REVISION
01
02

DATE
03/2015
06/2015

TEXT AFFECTED
Original Release
Modified Parts List

TABLE OF CONTENTS

| | <u>PAGE</u> |
|-------------|---|
| 1.0 | PRODUCT INFORMATION 1 |
| 1.1 | DESCRIPTION 1 |
| 1.2 | MODEL & SERIAL NUMBER 1 |
| 1.3 | MANUFACTURER 1 |
| 1.4 | SPECIFICATIONS 1 |
| 2.0 | SAFETY INFORMATION 2 |
| 2.1 | USAGE AND SAFETY INFORMATION 2 |
| 3.0 | TRAINING 2 |
| 3.1 | TRAINING REQUIREMENTS 2 |
| 4.0 | OPERATING INSTRUCTIONS 2 |
| 3.1 | OPERATING CONTROLS 3 |
| 4.2 | TO RAISE BOOM 3 |
| 4.3 | TO LOWER BOOM 3 |
| 5.0 | ADAPTER LISTING 4 |
| 6.0 | INSPECTION/MAINTENANCE 4 |
| 7.0 | PROVISION OF SPARES 4 |
| 7.1 | SOURCE OF SPARE PARTS 4 |
| 7.2 | RECOMMENDED SPARE PARTS LISTS 4 |
| 8.0 | IN SERVICE SUPPORT 4 |
| 9.0 | GUARANTEES/LIMITATION OF LIABILITY 5 |
| 10.0 | APPENDICES 5 |

This product can not be modified without the written approval of Tronair, Inc. Any modifications done without written approval voids all warranties and releases Tronair, Inc., its suppliers, distributors, employees, or financial institutions from any liability from consequences that may occur. Only Tronair OEM replacement parts shall be used.

1.0 PRODUCT INFORMATION

1.1 DESCRIPTION

This Tronair Strut Service Tool, Model 14-6906-0100, is designed to compress landing gear struts.

1.2 MODEL & SERIAL NUMBER

Reference nameplate on unit

1.3 MANUFACTURER

TRONAIR, Inc.
1 Air Cargo Pkwy East
Swanton, Ohio 43558 USA

Telephone: (419) 866-6301 or 800-426-6301

Fax: (419) 867-0634

E-mail: sales@tronair.com

Website: www.tronair.com

1.4 SPECIFICATIONS

- Maximum Lifting Capacity: 1,500 lbs (680.4 kg)
- Boom Height, Collapsed: 6.5 in (15.9 cm)
- Boom Height, Extended: 52 in (132.1 cm)
- Air Pressure Max: 150 psi (10.3 bar)
- Pump Pressure Relief: 950 psi (65.5 bar)

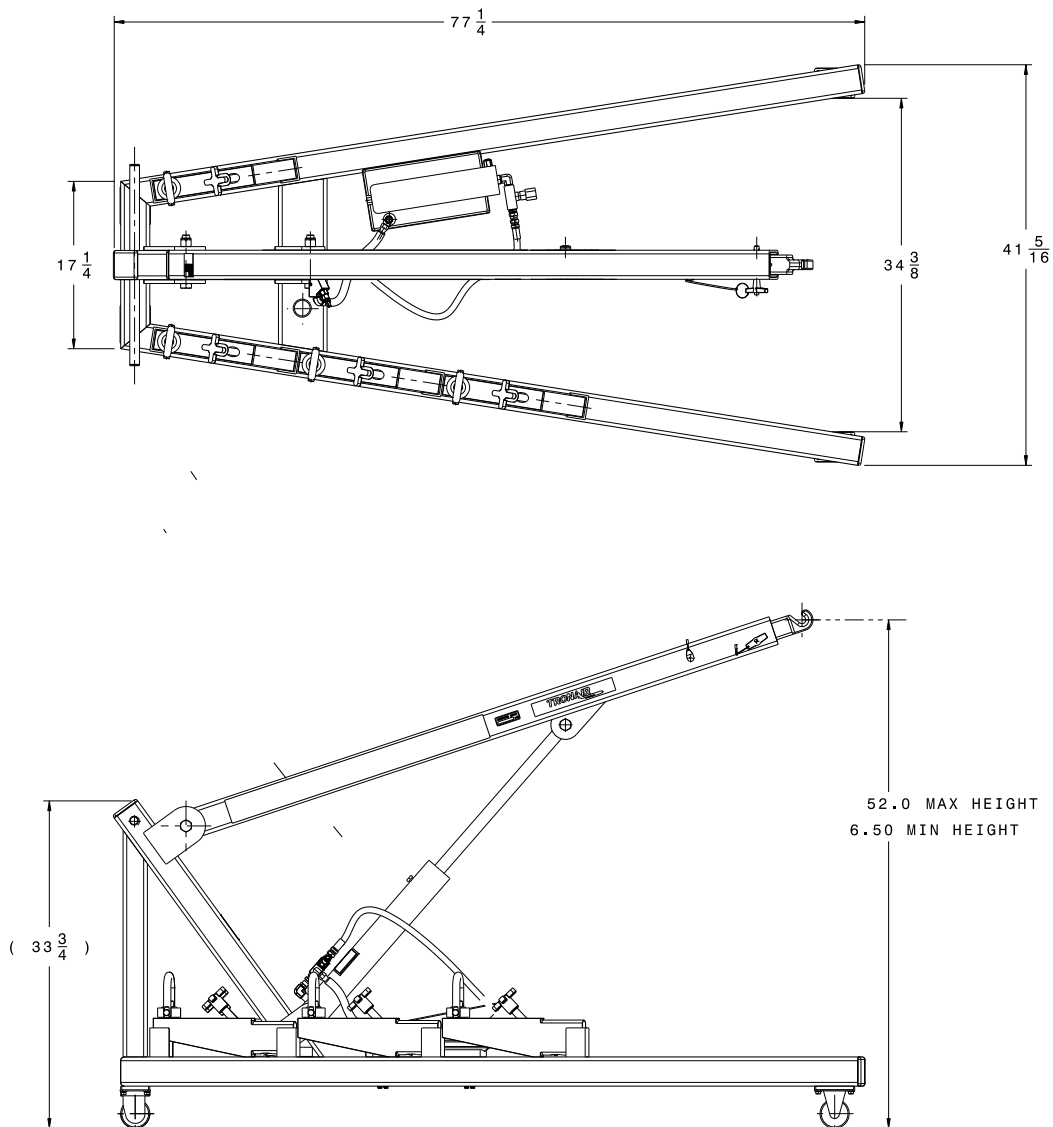

2.0 SAFETY INFORMATION

2.1 USAGE AND SAFETY INFORMATION

To insure safe operations please read the following statements and understand their meaning. Also refer to your equipment manufacturer's manual for other important safety information. This manual contains safety precautions which are explained below. Please read carefully.



WARNING! — Warning is used to indicate the presence of a hazard that **can cause severe personal injury, death, or substantial property damage** if the warning notice is ignored.

CAUTION! — Caution is used to indicate the presence of a hazard that **will or can cause minor personal injury or property damage** if the caution notice is ignored.

3.0 TRAINING

3.1 TRAINING REQUIREMENTS

The employer of the operator is responsible for providing a training program sufficient for the safe operation of the Strut Service Tool.

NOTE: *Maintenance and Trouble Shooting are to be performed by a skilled and trained technician.*

4.0 OPERATING INSTRUCTIONS



CAUTION!

Operator injury and/or component damage can result.

- Do not transport components on this lift.
- This lift is designed to only compress landing gear struts on aircraft.



Common Set Up



Universal Jack Pad



Gulfstream MLG Adapter

4.0 Operating instructions continued on following page.

4.0 OPERATING INSTRUCTIONS *(continued)*

4.1 OPERATING CONTROLS

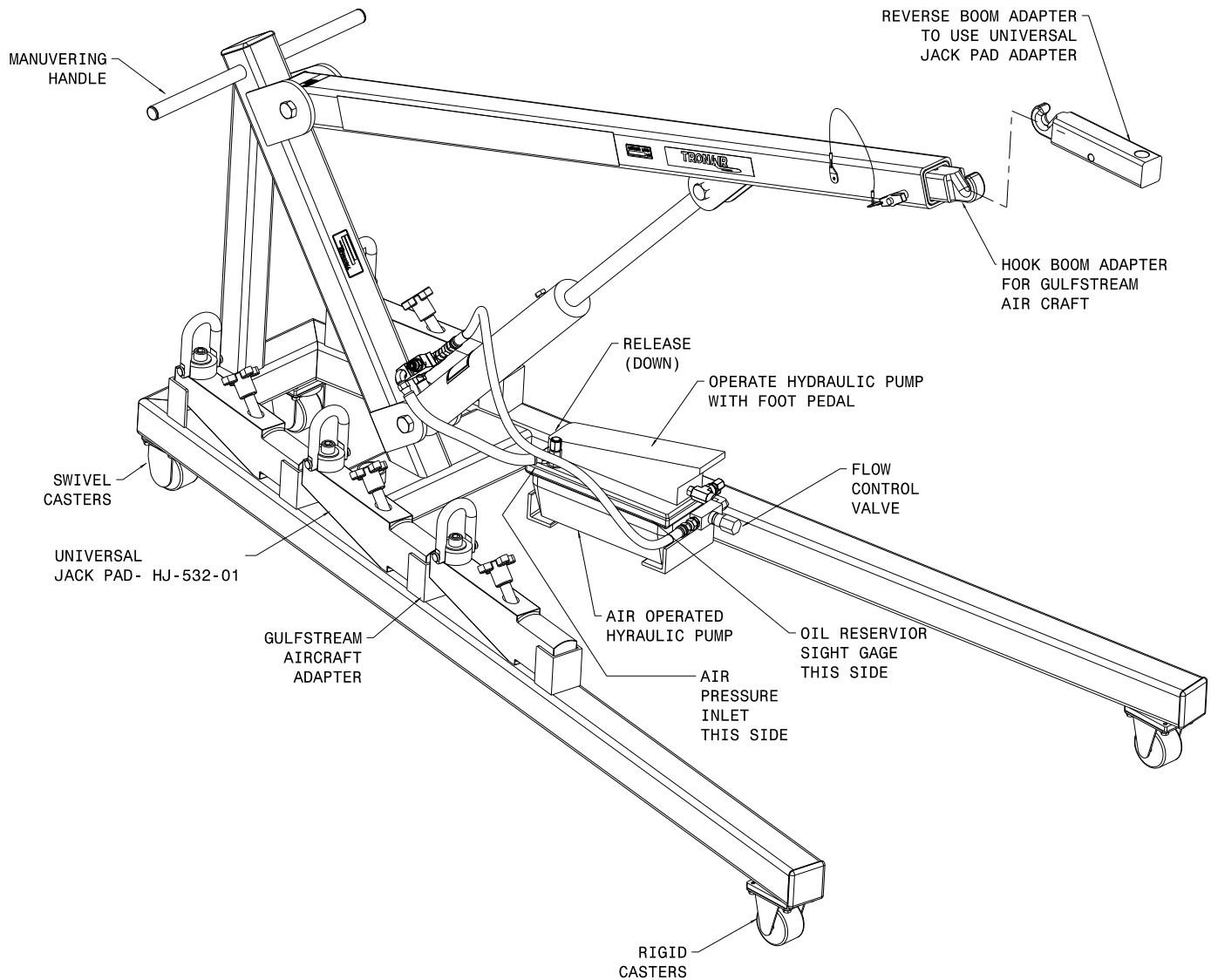

4.2 TO RAISE BOOM

1. Place Strut Service Tool on hard level surface.
2. Use appropriate adaptors.
3. Actuate foot pedal to "Pressure" side until desired boom height is reached.
4. Use flow control valve to adjust speed of boom.

4.3 TO LOWER BOOM

1. Actuate foot pedal to "release" side.
2. Use flow control valve to adjust speed of boom.



CAUTION!

Component damage and/or operator injury could result if release valve is opened too quickly.

5.0 ADAPTER LISTING

Included with unit

HJ-532-01 Universal jack adapter pad (.75 radius)

Sold Separately

K-4126..... Includes kits K-4127, K4128, K4129, K4130

K-4127..... Axle adapter assembly, 3.340 diameter, for Gulfstream GII, GIII, GIV, GIVSP, G400

K-4128..... Axle adapter assembly, 3.536 diameter, for Gulfstream GII, GIII, GIV, GIVSP, G400

K-4129..... Axle adapter assembly, 3.610 diameter, for Gulfstream GV, GVSP, G350, G450, G500, G550

K-4130..... Axle adapter assembly, 3.840 diameter, for Gulfstream GV, GVSP, G350, G450, G500, G550

NOTE: Aircraft adapters will vary depending on Gulfstream aircraft model and aircraft service change 155

6.0 INSPECTION/MAINTENANCE

To keep your Tronair equipment fully operational and last for years you should adhere to the following suggestions:

1. Before each use:
Visually inspect unit to ensure all components are present and functional
 - a. All pivot bolts & nuts are secure
 - b. Cylinder is free of leaks & relief valve is operational
 - c. All casters & locks are operational
 - d. No bent or broken components



WARNING!

Ensure lift components are free of damage and or excessive wear. Never use lift if any component is bent or broken

2. Periodically:
Check cylinder reservoir level. Replenish with MIL-5606
 - a. Check oil level with cylinder fully retracted
 - b. Ensure Fluid is at acceptable level

3. Annually:
Check pump pressure relief.



WARNING!

Pressure relief is factory set. DO NOT attempt to reset or adjust the relief valve. Send pump to an authorized Enerpac dealer.



WARNING!

Failure to remove landing gear strut servicing tool prior to inflating shock strut may cause fatal or serious injuries to personnel and damage to aircraft.

7.0 PROVISION OF SPARES

7.1 SOURCE OF SPARE PARTS

Spare parts may be obtained from the manufacturer:

TRONAIR, Inc.
1 Air Cargo Pkwy East
Swanton, Ohio 43558 USA

Telephone: (419) 866-6301 or 800-426-6301
Fax: (419) 867-0634
E-mail: sales@tronair.com
Website: www.tronair.com

7.2 RECOMMENDED SPARE PARTS LISTS

Reference the following page(s) for Replacement Parts and Kits available.

8.0 IN SERVICE SUPPORT

Contact Tronair, Inc. for technical services and information. See Section 1.3 – Manufacturer.

9.0 GUARANTEES/LIMITATION OF LIABILITY

Tronair products are warranted to be free of manufacturing or material defects for a period of one year after shipment to the original customer. This is solely limited to the repair or replacement of defective components. This warranty does not cover the following items:

- a) Parts required for normal maintenance
- b) Parts covered by a component manufacturers warranty
- c) Replacement parts have a 90-day warranty from date of shipment

If you have a problem that may require service, contact Tronair immediately. Do not attempt to repair or disassemble a product without first contacting Tronair, any action may affect warranty coverage. When you contact Tronair be prepared to provide the following information:

- a) Product Model Number
- b) Product Serial Number
- c) Description of the problem

If warranty coverage is approved, either replacement parts will be sent or the product will have to be returned to Tronair for repairs. If the product is to be returned, a Return Material Authorization (RMA) number will be issued for reference purposes on any shipping documents. Failure to obtain a RMA in advance of returning an item will result in a service fee. A decision on the extent of warranty coverage on returned products is reserved pending inspection at Tronair. Any shipments to Tronair must be shipped freight prepaid. Freight costs on shipments to customers will be paid by Tronair on any warranty claims only. Any unauthorized modification of the Tronair products or use of the Tronair products in violation of cautions and warnings in any manual (including updates) or safety bulletins published or delivered by Tronair will immediately void any warranty, express or implied.

The obligations of Tronair expressly stated herein are in lieu of all other warranties or conditions expressed or implied. **Any unauthorized modification of the Tronair products or use of the Tronair products in violations of cautions and warnings in any manual (including updates) or safety bulletins published or delivered by Tronair will immediately void any warranty, express or implied and Tronair disclaims any and all liability for injury (WITHOUT LIMITATION and including DEATH), loss or damage arising from or relating to such misuse.**

10.0 APPENDICES

APPENDIX I Declaration of Conformity

This page left blank intentionally.

Parts List

When ordering replacement parts/kits, please specify model, serial number and color of your unit.

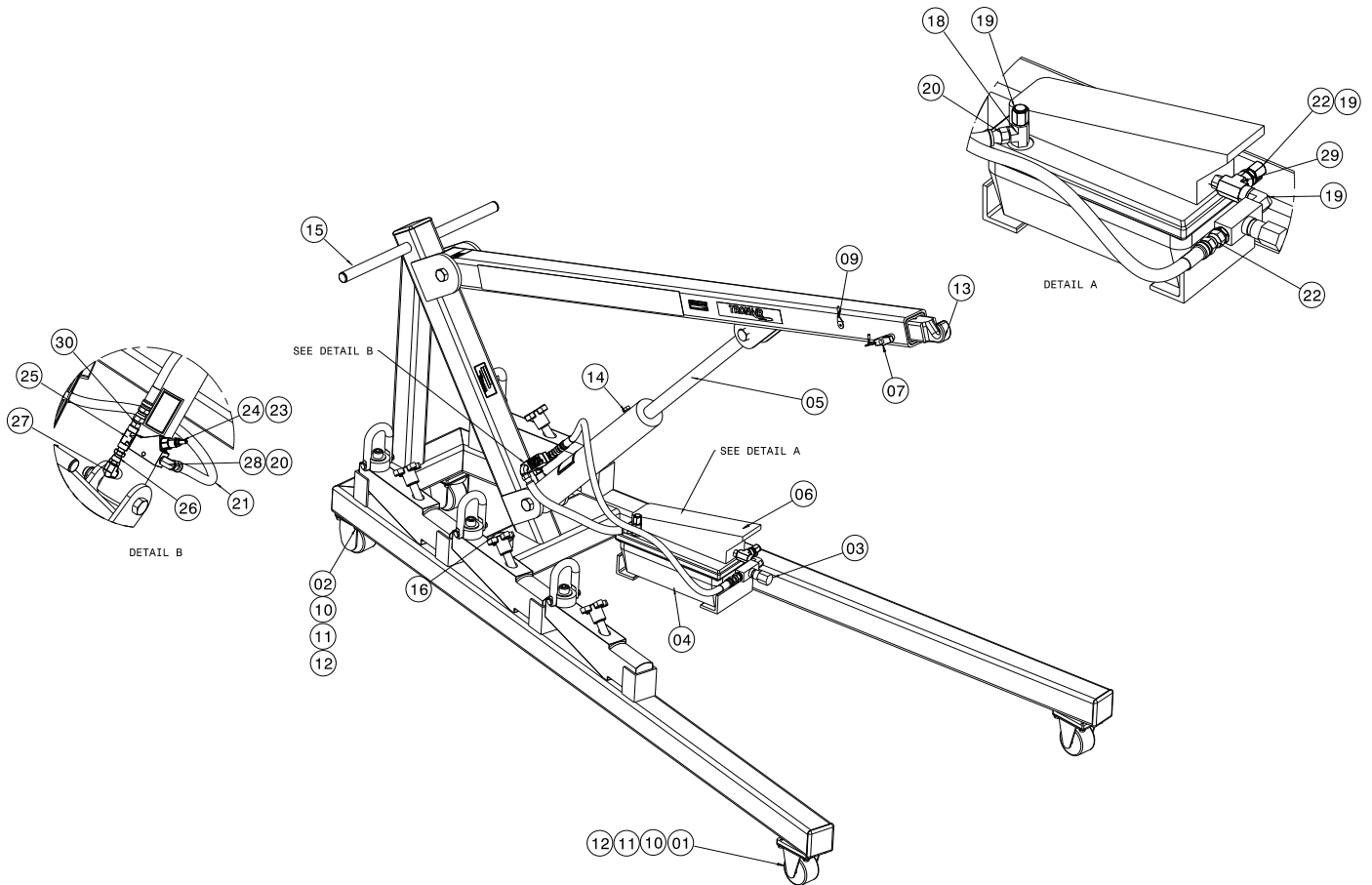

| Item | Part Number | Description | Qty |
|------|------------------|------------------------------|-----|
| 1 | U-1123 | Caster, Rigid | 2 |
| 2 | U-1124 | Caster, Swivel | 2 |
| 3 | HC-2247 | Valve, Flow Control | 1 |
| 4 | TF-1043-06*38.00 | Hose, 3/8 ID | 1 |
| 5 | HC-2346 | Cylinder, Hydraulic | 1 |
| 6 | HC-2347 | Pump, Hydraulic | 1 |
| 7 | G-1310-0831 | Pin, T-Handle Ball Lock | 1 |
| 8 | H-1026*07.0 | Lanyard | 1 |
| 9 | G-1351-02 | Rivet | 1 |
| 10 | G-1100-106504 | Bolt | 16 |
| 11 | G-1250-1060N | Flatwasher | 16 |
| 12 | G-1251-1060R | Lockwasher | 16 |
| 13 | J-4122 | Adapter, Hook | 1 |
| 14 | H-3016 | Vent, Breather | 1 |
| 15 | H-2589 | Cap, Plug | 2 |
| 16 | HJ-532-01 | Pad, Jack | 1 |
| 17 | H-2649-16 | Cap, Plug | 2 |
| 18 | N-2017-10-S | Tee, Male Run | 1 |
| 19 | N-2008-05-S | Cap | 2 |
| 20 | N-2026-03-S | Swivel, JIC 37° Hose Fitting | 2 |

Parts List

When ordering replacement parts/kits, please specify model, serial number and color of your unit.

| Item | Part Number | Description | Qty |
|------|-----------------|-------------------------------|-----|
| 21 | TF-1047-04*15.0 | Hose, 3/8 Gray | 1 |
| 22 | N-2009-10-S | Swivel, Female, 37° JIC x 3/8 | 2 |
| 23 | HC-2653 | Manifold, In-Line | 1 |
| 24 | HC-2652 | Cartridge, Relief Valve | 1 |
| 25 | N-2208-03-S | Tee, Male Branch | 1 |
| 26 | N-2030-03-S | Swivel, #6 JIC x 1/4 NPT | 1 |
| 27 | N-2005-10-S | Elbow, 3/8 Male | 1 |
| 28 | N-2005-08-S | Elbow, Male | 1 |
| 29 | N-2209-06-S | Tee, Street | 1 |
| 30 | N-2009-08-S | Connector, Male | 1 |



APPENDIX I

Declaration of Conformity



DECLARATION of CONFORMITY

The design, development and manufacture is in accordance with European Community guidelines

Strut Service Tool
14-6906-0100

Relevant provisions complied with by the machinery:
2006/42/EC

Relevant standards complied with by the machinery:
EN ISO 12100-1

Identification of person empowered to sign on behalf of the Manufacturer:

A handwritten signature in cursive script that reads "Patrick Finch". The signature is written in black ink and is positioned above a horizontal line.

Quality Assurance Representative