



**Model: 14-6911-0100
Universal Tool
Strut, Brake, Tire**



08/2021 – Rev. 03

REVISION

01
02
03

DATE

10/2008
02/2012
08/2021

TEXT AFFECTED

Original Release
Added CE Marking and Appendix I
Major revision

TABLE OF CONTENTS**PAGE**

1.0	PRODUCT INFORMATION	1
1.1	DESCRIPTION.....	1
1.2	MODEL & SERIAL NUMBER.....	1
1.3	MANUFACTURER	1
1.4	USAGE	1
1.5	SPECIFICATIONS	1
2.0	SAFETY INFORMATION	1
2.1	USAGE AND SAFETY INFORMATION	1
3.0	TRAINING	2
3.1	TRAINING REQUIREMENTS	2
3.2	TRAINING PROGRAM	2
3.3	OPERATOR TRAINING.....	2
4.0	HAND CONTROL AND OPERATION	2
4.1	OPERATING INSTRUCTIONS	3
5.0	MAINTENANCE	5
5.1	PREVENTATIVE MAINTENANCE	5
6.0	PROVISION OF SPARES	5
6.1	SOURCE OF SPARE PARTS.....	5
6.2	RECOMMENDED SPARE PARTS LISTS	5
7.0	IN SERVICE SUPPORT	5
8.0	GUARANTEES/LIMITATION OF LIABILITY	6
9.0	APPENDICES	6

This product can not be modified without the written approval of Tronair, Inc. Any modifications done without written approval voids all warranties and releases Tronair, Inc., its suppliers, distributors, employees, or financial institutions from any liability from consequences that may occur. Only Tronair OEM replacement parts shall be used.

1.0 PRODUCT INFORMATION

1.1 DESCRIPTION

The Tronair Model 14-6911-0100 incorporates the following quality features:

- Low profile
- No need to remove tire when servicing struts
- Fits 14" to 30" tire
- Long handle for ease of lifting
- Wide, heavy duty, steel saddle for both nose and main tires
- Easy clamp to lock tire in place
- Relief valve to prevent lifting aircraft
- 2 swivel casters for easy maneuverability
- No mark rubber wheels
- Powder Coat Tronair Blue

1.2 MODEL & SERIAL NUMBER

Reference nameplate on unit

1.3 MANUFACTURER

TRONAIR, Inc.
1 Air Cargo Pkwy East
Swanton, Ohio 43558 USA

Telephone: (419) 866-6301 or 800-426-6301
Fax: (419) 867-0634
E-mail: sales@tronair.com
Website: www.tronair.com

1.4 USAGE

Universal strut tool is for the service of struts, breaks and tires on aircraft.



WARNING!—Warning is used to indicate the presence of a hazard that **can cause severe personal injury, death, or substantial property damage** if the warning notice is ignored.

CAUTION!—Caution is used to indicate the presence of a hazard that will or can cause minor personal injury or property damage if the caution notice is ignored.

1.5 SPECIFICATIONS

Capacity 800 lbs (362.9)
Lift Range
 Collapsed 2.75 in (1 cm)
 Fully Extended 20 in (7.9 cm)
Weight 143 lbs (315 kg)

2.0 SAFETY INFORMATION

2.1 USAGE AND SAFETY INFORMATION

To insure safe operations please read the following statements and understand their meaning. Also refer to your equipment manufacturer's manual for other important safety information. This manual contains safety precautions which are explained below. Please read carefully.



WARNING!
Warning is used to indicate the presence of a hazard that can cause **severe personal injury, death, and/or substantial property damage** if the Warning Notice is ignored.



CAUTION!
Caution is used to indicate the presence of a hazard, which will or can cause **minor personal injury or property damage** if the Caution Notice is ignored.

3.0 TRAINING**3.1 TRAINING REQUIREMENTS**

The employer of the operator is responsible for providing a training program sufficient for the safe operation of the unit.

3.2 TRAINING PROGRAM

The employer provided operator training program should cover safety procedures concerning use of the unit in and around the intended aircraft at the intended aircraft servicing location.

3.3 OPERATOR TRAINING

The operator training should provide the required training for safe operation of the unit.

NOTE: Maintenance and Trouble Shooting are to be performed by a skilled and trained technician.

4.0 HAND CONTROL AND OPERATION**WARNING!**

Read These Instructions Before Operating!

Before using this jack, read this manual completely and thoroughly, understanding its operating procedures, safety warnings and maintenance requirements. Failure to do so could cause accidents resulting in serious or fatal personal injury and/or property damage.

**WARNING!**

- **Inspect the jack before use. Do not use the jack if it is damaged, altered, modified, in poor condition, leaking hydraulic fluid, or unstable due to loose hardware. Take corrective action before using the jack.**
- **This jack was designed for exercising struts and tire and brake removal only. The jack is not intended to suspend a load for an indefinite period of time.**
- **For lighter aircraft, great care needs to be taken not to lift aircraft off jacks when servicing struts.**
- **DO NOT move or dolly the aircraft while on the jack.**
- **Lift only dead weight.**
- **Center load on saddle. Be sure setup is stable, Off-center loads can cause jack failure and/or loss of load.**
- **Use the jack on a hard level surface. The jack must be free to roll and reposition itself while lifting or lowering the aircraft.**
- **DO NOT modify the jack or use saddle adapters or saddle extenders unless approved or supplied by Tronair.**
- **ALWAYS lower the jack slowly and carefully.**

4.0 **HAND CONTROL AND OPERATION** *(continued)*
 4.1 **OPERATING INSTRUCTIONS**

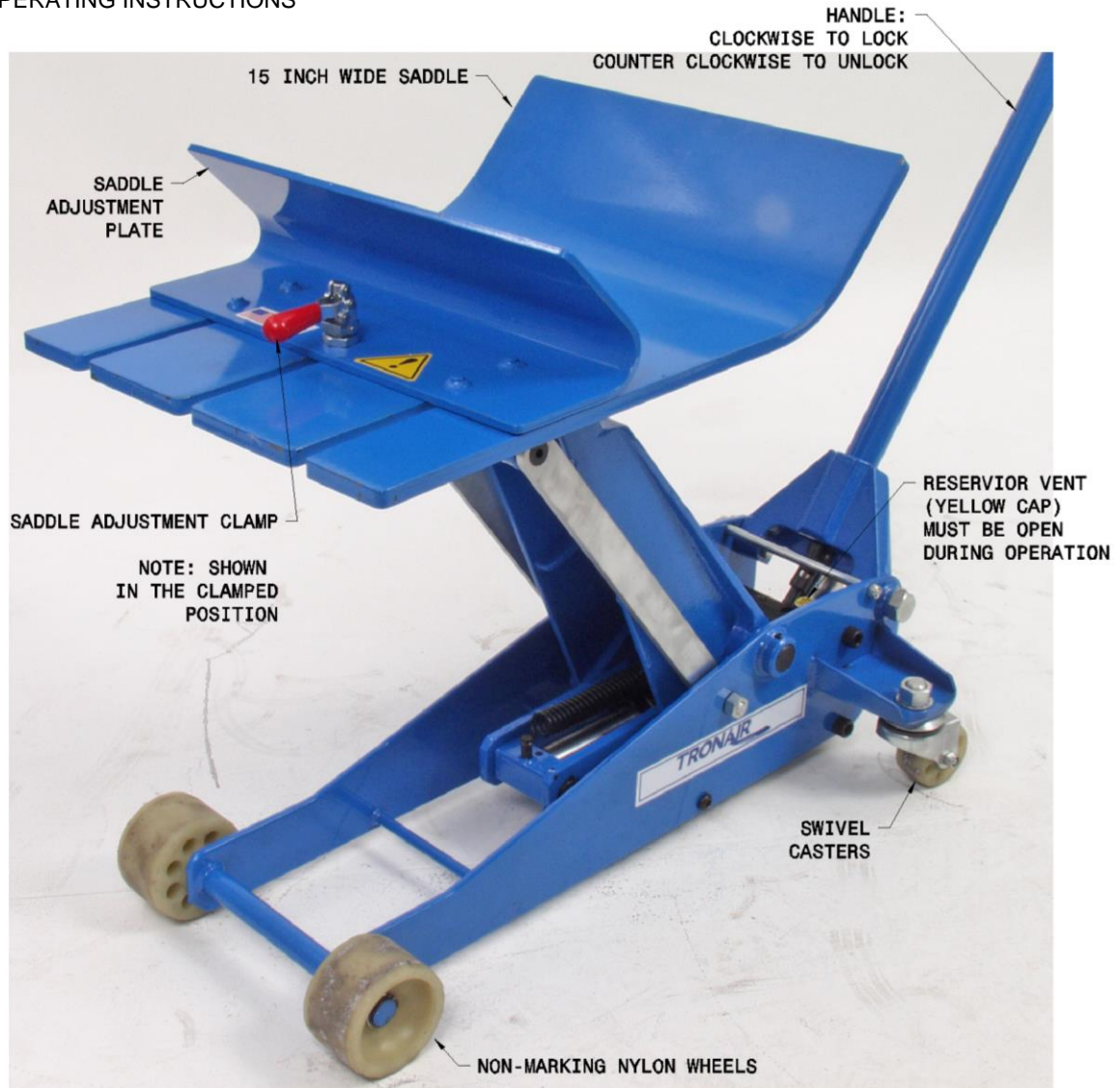

1. Become familiar with the operation of the handle. Turning the handle in a clockwise direction until tightened will enable the jack lifting arm to be raised when pumping the handle up and down. Turning the handle in a counterclockwise direction will enable the jack lifting arm to be lowered.

NOTE: *It will never be necessary to turn the handle more than two complete revolutions in the counterclockwise direction. When lowering the load, be careful to turn the handle in a counterclockwise direction very SLOWLY for controlled lowering of the load.*

2. With the jack in the lowered position remove saddle adjustment plate and push the jack under the aircraft.

4.1 OPERATING INSTRUCTIONS *(continued)*

3. Install adjustment plate and clamp. Make sure tire is wedged in cradle as shown.



4. Close the release valve in preparation for lifting the load by turning the handle in a clockwise direction until tight. Pump the jack handle to raise the lifting saddle up to the recommended lifting point. Check to see that the lifting point is centered on the lifting saddle and the majority of the weight is not supported by the peripheral edge of the lifting saddle at any single point.

NOTE: Check to see that the ground surface around the jack is free from wheel obstructions such as gravel, tools, or uneven joints or edges. The jack will have a tendency to reposition itself during the lifting process and therefore should not be hindered by wheel obstructions.

5. Proceed with pumping the jack so the load is lifted to the required work height. DO NOT ATTEMPT TO RAISE THE JACK BEYOND ITS ELEVATOR ARM STOP PINS. The maximum lift height is 21".
6. Lower the load **SLOWLY AND CAREFULLY** by turning the jack handle in a counterclockwise direction very slowly.

5.0 MAINTENANCE**5.1 PREVENTATIVE MAINTENANCE**

1. ALWAYS store the jack in a well protected area where it will not be exposed to inclement weather, corrosive vapors, abrasive dust, or any other harmful elements. The jack must be cleaned of water, snow, sand, or grit before using.
2. The jack must be lubricated periodically in order to prevent premature wearing of parts. A general purpose grease MUST be applied to caster wheels, front axle wheels, elevator arm, handle base pivot bolts, release mechanism and all other bearing surfaces. See the parts list for the location of above mentioned parts. Failure to maintain proper lubrication voids warranty.
3. It should not be necessary to refill or top off the reservoir with hydraulic fluid unless there is an external leak. An external leak requires immediate repair which must be performed in a dirt-free environment by qualified hydraulic repair personnel who are familiar with this equipment.

NOTE: *In order to prevent seal damage and jack failure, NEVER use alcohol, hydraulic brake fluid, or transmission oil in the jack.*

4. Every jack owner is responsible for keeping the jack label clean and readable. Use mild soap solution to wash external surfaces of the jack but not any moving hydraulic components.
5. Inspect the jack before each use. DO NOT use the jack if any component is cracked, broken, bent, shows signs of damage, or leaks hydraulic fluid. DO NOT use the jack if it has loose or missing hardware or components, or is modified in any way. Take corrective action before using the jack again.
6. DO NOT attempt to make any hydraulic repair unless you are a qualified hydraulic repair person that is familiar with this equipment.

6.0 PROVISION OF SPARES**6.1 SOURCE OF SPARE PARTS**

Spare parts may be obtained from the manufacturer:

TRONAIR, Inc.

1 Air Cargo Pkwy East

Swanton, Ohio 43558 USA

Telephone: (419) 866-6301 or 800-426-6301

Fax: (419) 867-0634

E-mail: sales@tronair.com

Website: www.tronair.com

6.2 RECOMMENDED SPARE PARTS LISTS

Reference the following page(s) for Replacement Parts and Kits available.

7.0 IN SERVICE SUPPORT

Contact Tronair, Inc. for technical services and information. See Section 1.3 – Manufacturer.

8.0 GUARANTEES/LIMITATION OF LIABILITY

Tronair products are warranted to be free of manufacturing or material defects for a period of one year after shipment to the original customer. This is solely limited to the repair or replacement of defective components. This warranty does not cover the following items:

- a) Parts required for normal maintenance
- b) Parts covered by a component manufacturers warranty
- c) Replacement parts have a 90-day warranty from date of shipment

If you have a problem that may require service, contact Tronair immediately. Do not attempt to repair or disassemble a product without first contacting Tronair, any action may affect warranty coverage. When you contact Tronair be prepared to provide the following information:

- a) Product Model Number
- b) Product Serial Number
- c) Description of the problem

If warranty coverage is approved, either replacement parts will be sent or the product will have to be returned to Tronair for repairs. If the product is to be returned, a Return Material Authorization (RMA) number will be issued for reference purposes on any shipping documents. Failure to obtain a RMA in advance of returning an item will result in a service fee. A decision on the extent of warranty coverage on returned products is reserved pending inspection at Tronair. Any shipments to Tronair must be shipped freight prepaid. Freight costs on shipments to customers will be paid by Tronair on any warranty claims only. Any unauthorized modification of the Tronair products or use of the Tronair products in violation of cautions and warnings in any manual (including updates) or safety bulletins published or delivered by Tronair will immediately void any warranty, express or implied.

The obligations of Tronair expressly stated herein are in lieu of all other warranties or conditions expressed or implied. **Any unauthorized modification of the Tronair products or use of the Tronair products in violations of cautions and warnings in any manual (including updates) or safety bulletins published or delivered by Tronair will immediately void any warranty, express or implied and Tronair disclaims any and all liability for injury (WITHOUT LIMITATION and including DEATH), loss or damage arising from or relating to such misuse.**

9.0 APPENDICES

- APPENDIX I Declaration Of Conformity
- APPENDIX II Norco Floor Service Jack

Parts List

When ordering replacement parts/kits, please specify model, serial number and color of your unit.



Item	Part Number	Description	Qty
1	Z-11259-00	Jack, Floor	1
2	Z-11255	Assembly, Saddle	1
3	G-1100-109506	Bolt, Hex Head GR 5, ½ - 20 x ¾ Long	1
4	H-3170	Spring, Pressure Release	1
5	V-1003	Label, Serial Number	1
6	V-1805	Label, ISO General Danger	1
7	V-1983	Label, Working Load	1
8	V-1002	Label, Tronair	2
9	V-1198	Label, Tronair	1
10	V-1001	Label, Made In USA	1
12	V-1999	Label, ISO Hand Crush	1



APPENDIX I

Declaration of Conformity



DECLARATION of CONFORMITY

The design, development and manufacture is in accordance with European Community guidelines

14-6911-0100

Relevant provisions complied with by the machinery:
2006/42/EC

Identification of person empowered to sign on behalf of the Manufacturer:

A handwritten signature in cursive script that reads "Patrick Finch". The signature is written in black ink and is positioned above a solid horizontal line.

Quality Assurance Representative



APPENDIX II

**Norco
Floor Service Jack**



PROFESSIONAL LIFTING EQUIPMENT

MODEL 71233A 2 TON DOUBLE-PUMP FLOOR JACK SETUP • OPERATING • MAINTENANCE INSTRUCTIONS

IMPORTANT: READ THESE INSTRUCTIONS BEFORE OPERATING

BEFORE USING THIS JACK, READ THIS MANUAL COMPLETELY AND THOROUGHLY, UNDERSTAND ITS OPERATING PROCEDURES, SAFETY WARNINGS AND MAINTENANCE REQUIREMENTS. FAILURE TO DO SO COULD CAUSE ACCIDENTS RESULTING IN SERIOUS OR FATAL PERSONAL INJURY AND/OR PROPERTY DAMAGE.

The use of portable automotive lifting devices is subject to certain hazards that cannot be prevented by mechanical means, but only by the exercise of intelligence, care, and common sense. It is therefore essential to have owners and personnel involved in the use and operation of equipment who are careful, competent, trained, and qualified in the safe operation of the equipment and its proper use. Examples of hazards are dropping, tipping, or slipping of motor vehicles or their components caused primarily by improperly securing loads, overloading, off-centered loads, use on

other than hard level surfaces, and using equipment for a purpose for which it was not designed.

It is the responsibility of the owner to make sure all personnel read this manual prior to using this device. It is also the responsibility of the device owner to keep this manual intact and in a convenient location for all to see and read. If the manual is lost or not legible, contact Norco Industries, Inc. for a free replacement. If the operator is not fluent in English, the product and safety instructions shall be read to and discussed with the operator in the operator's native language by the purchaser/ owner or his designee, making sure that the operator comprehends its contents.

WARRANTY

This floor service jack is covered by a Limited Lifetime Warranty. For details see the back cover of Norco's product catalog.

WARNING

- Before lifting a vehicle, refer to the vehicle's service manual or inquire from the vehicle manufacturer the recommended jack lifting points and jack stand support surfaces on the vehicle chassis.
 - Inspect the jack before each use. Do not use the jack if it is damaged, altered, modified, in poor condition, leaking hydraulic fluid, or unstable due to loose hardware. Take corrective action before using the jack.
 - This jack was designed for lifting purposes only. Do not attempt to work on the vehicle until jack stands rated equal to or greater than the rated capacity of the jack are positioned to support the load.
 - Do not move or dolly the vehicle while on the jack.
 - Do not use the jack beyond its rated capacity. Lift only dead weight.
 - Center load on saddle. Be sure setup is stable. Off-center loads can cause jack failure and/or loss of load.
 - Use the jack on a hard level surface. The jack must be free to roll and reposition itself while lifting or lowering the vehicle.
 - Do not modify the jack or use saddle adapters or saddle extenders unless approved or supplied by Norco.
 - Always lower the jack slowly and carefully.
-

SETUP

1. If your jack is equipped with a two-piece handle, fit the handle halves together and secure them by tightening the bolt and nut provided.
2. Using an open end or socket wrench, remove the hexagonal head screw located on top of the handle receiver so the handle can be inserted all the way.
3. Insert the handle in the handle receiver making sure the configuration at the end of the handle fits into the slotted position of the mechanism inside the handle receiver. The outside groove at the bottom of the handle should align with the screw hole in the handle receiver.
4. Install the hexagonal head screw in the screw hole in the bottom of the handle receiver and tighten. This will secure the handle in the handle receiver allowing you to maneuver the jack. The hexagonal head screw will not bottom out on the handle thus allowing you to rotate the handle in either direction for activation of the release valve to either raise or lower the jack.
5. Sometimes air gets trapped in the hydraulic system during shipment. An air bound hydraulic system feels spongy when pumped and sometimes the jack will not pump full incremental strokes.

PURGING AIR FROM THE HYDRAULIC SYSTEM

- a. Open the release valve by turning the handle in a counterclockwise direction two full turns.
- b. Pump the handle ten full strokes.
- c. Close the release valve by turning the handle in a clockwise direction until tight.
- d. Pump the jack until the lift arm is extended to maximum height.
- e. If the condition seems better, repeat steps "a" through "d" until all the air is purged from the system.

OPERATING INSTRUCTIONS

1. Become familiar with the operation of the handle. Turning the handle in a clockwise direction until tightened will enable the jack lift arm to be raised when pumping the handle up and down. Turning the handle in a counterclockwise direction will enable the jack lift arm to be lowered. **IMPORTANT: It will never be necessary to turn the handle more than two complete revolutions in the counterclockwise direction. When lowering a load, be careful to turn the handle in a counterclockwise direction very slowly for controlled lowering of the load.**
2. With the jack in the lowered position, push the jack under the vehicle. **IMPORTANT: Use the manufacturer's recommended lifting procedures and lifting points before lifting loads.**
3. Close the release valve in preparation for lifting the load by turning the handle in a clockwise direction until tight. Pump the jack handle to raise the lifting saddle up to the recommended lifting point. Check to see that the lifting point is centered on the lifting saddle and the majority of the weight is not supported by the peripheral edge of the lifting saddle at any single point.
4. **IMPORTANT: Check to see that the ground surface around the jack is free from wheel obstructions such as gravel, tools, or uneven joints or edges. The jack will have a tendency to reposition itself during the lifting process and therefore must not be hindered by wheel obstructions.**
5. Proceed with pumping the jack so the load is lifted to the required work height.
6. After lifting the load, always use vehicle support stands with an adequate capacity rating to support the load before making any repairs or adjustments. Position and adjust the stands under the load at points that will provide stable support. Lower the load **SLOWLY AND CAREFULLY** onto the support stands by turning the jack handle in a counterclockwise direction very slowly. Although jack stands are individually rated, they are to be used in a matched pair to support one end of a vehicle only. Stands are not to be used to simultaneously support both ends or one side of a vehicle.

PREVENTATIVE MAINTENANCE

1. Always store the jack in a well protected area where it will not be exposed to inclement weather, corrosive vapors, abrasive dust, or any other harmful elements. The jack must be cleaned of water, snow, sand, or grit before using.
 2. The jack must be lubricated periodically in order to prevent premature wearing of parts. A general purpose grease must be applied to caster wheels, front axle wheels, elevator arm, handle base pivot bolts, release mechanism and all other bearing surfaces. See the exploded view parts drawing for the location of the above mentioned parts. Failure to maintain proper lubrication voids warranty.
 3. It should not be necessary to refill or top off the reservoir with hydraulic fluid unless there is an external leak. An external leak requires immediate repair which must be performed in a dirt-free environment by qualified hydraulic repair personnel who are familiar with this equipment. Norco Authorized Service Centers are recommended.
- IMPORTANT: In order to prevent seal damage and jack failure, never use alcohol, hydraulic brake fluid, or transmission oil in the jack.**
4. Every jack owner is responsible for keeping the jack label clean and readable. Use a mild soap solution to wash external surfaces of the jack but not any moving hydraulic components. Contact Norco Industries for a replacement label if your jack's label is unreadable.
 5. Inspect the jack before each use. Do not use the jack if any component is cracked, broken, bent, shows sign of damage, or leaks hydraulic fluid. Do not use the jack if it has loose or missing hardware or components, or is modified in any way. Take corrective action before using the jack again.
 6. Do not attempt to make any hydraulic repairs unless you are a qualified hydraulic repair person that is familiar with this equipment.

REPAIR SERVICE

If your Norco product requires service or repair, contact the Norco Customer Service Department for the location of the nearest Norco Authorized Service Center.

Norco Industries, Inc.
365 West Victoria St.
Compton, CA 90220
(310) 639-4000 • Fax: (310) 639-7411
www.norcoindustries.com

It will be necessary to provide the Norco Authorized Service Center with a copy of the bill of sale if requesting warranty repair. If the authorized service center determines your product is eligible for warranty repair, the repair will be made at no charge and returned freight prepaid. The cost of non-warrantable service, repair, and return freight is the customer's responsibility.

INDEX NO.	DESCRIPTION	PART NO.	REQ'D NO.
1	Retaining Ring	214401	2
2	Washer	214402	2
3	Wheel	214403	2
4	Side Plate Assembly	N/A	4
5	Washer M12	214404	4
6	Hex Nut M12	214406	2
7	Caster Assembly	214407	2
8	Hex Bolt M12X20	214408	2
10	Bolt	214411	2
11	Spring Washer	214412	2
12	Nut M16	214413	2
13	Spring Washer 16	214414	2
14	Torsion Spring	214416	1
15	Handle Socket	214417	1
16	Bolt	214418	1
17	Upper Handle	214419	1
18	Hex Bolt M8X25	214421	1
19	Lower Handle	214422	1
20	Power Unit Assembly	214425	1

INDEX NO.	DESCRIPTION	PART NO.	REQ'D NO.
71	Bolt	214507	1
72	Split Pin 4X45	214507	1
73	Spring	214423	2
74	Hex Nut M20	214424	2
75	Shaft Arm	214488	1
76	Bolt	214489	2
77	Retaining Ring	214491	2
78	Long Linkage	214492	2
79	Block Linkage	214493	1
80	Retaining Ring 16	214494	2
81	Saddle Block	214496	1
82	Saddle	214495	1
83	Linkage Axle	214497	1
84	Washer 20	214498	2
85	Bush	214499	1
86	Pull Rod	214501	1
87	Washer 12	215402	2
88	Nut M12	215403	2
89	Lift Arm Assembly	214504	1
90	Handle Bumper	214506	1
	Repair Kit	214400	1

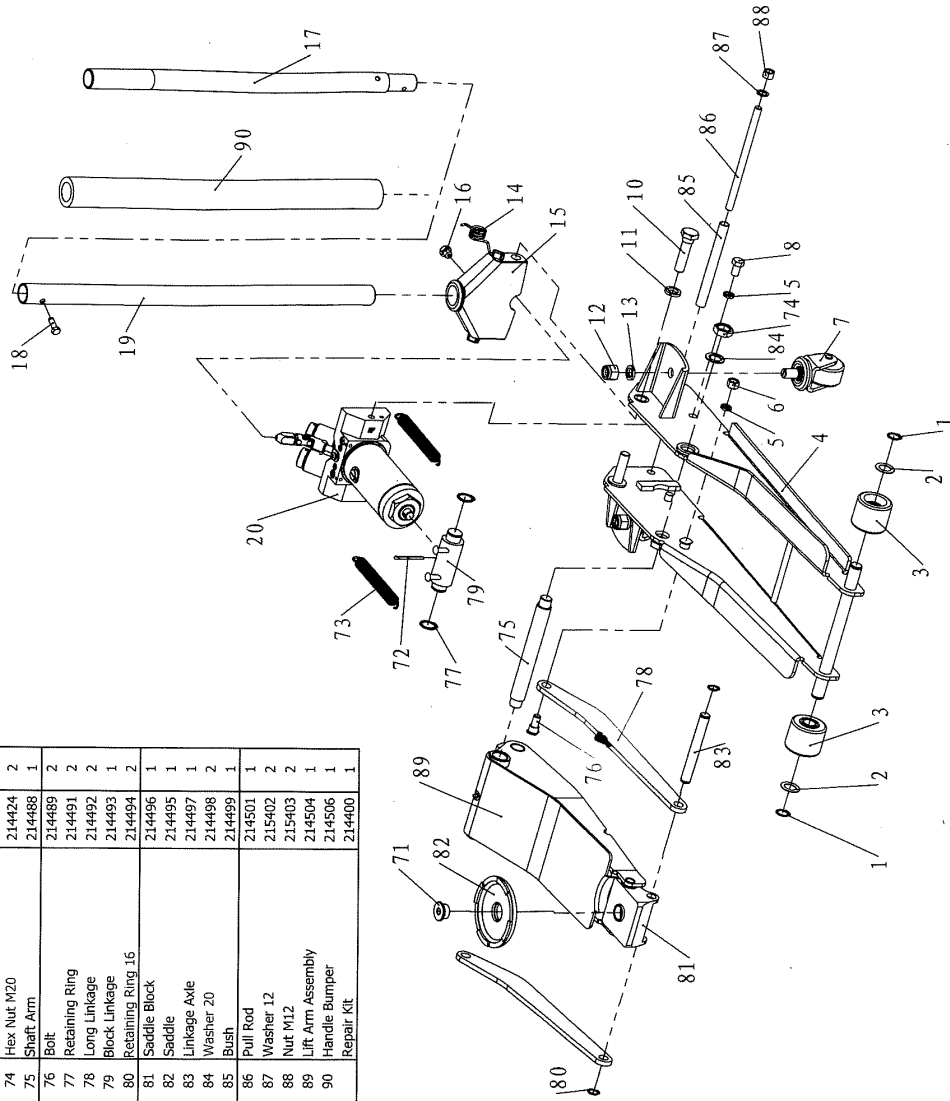

REPLACEMENT PARTS

MODEL NO.
71233A

CAPACITY
2 TON

DESCRIPTION
HYDRAULIC FLOOR JACK W/ DOUBLE PUMP PISTON