



## Operation & Service Manual



**Model: 17A7503F7000**  
**Mobile Air Conditioner (MACH IV)**  
**208 VAC – 3 Phase – 60 Hz**  
**with Heater Option**

09/2009 – Rev. 05

Includes Illustrated Parts List

**For Spare Parts, Operations & Service Manuals or Service Needs**  
**Scan the QR code or visit [Tronair.com/aftermarket](http://Tronair.com/aftermarket)**



The Tronair Group of Companies: Tronair | EBIS | Columbus Jack | Eagle | DAE | Malabar International

**Tronair, Inc.**  
1 Air Cargo Pkwy East  
Swanton, OH 43558

Phone: (419) 866-6301 | 800-426-6301  
Web: [www.tronair.com](http://www.tronair.com)  
Email: [sales@tronair.com](mailto:sales@tronair.com)



**TABLE OF CONTENTS**

**PAGE**

1.0	Description.....	1
2.0	Usage And Safety Information.....	1
2.1	Usage .....	1
2.2	Safety Considerations.....	1
2.3	Safety Precautions.....	1
3.0	Features, Benefits And Ratings.....	2
3.1	Features/Benefits.....	2
3.2	Ratings.....	2
3.3	Electrical Data.....	2
3.4	208 Volt Versus 230 Volt .....	3
3.5	Field Power Supply.....	3
3.6	Trailer.....	4
4.0	Electrical Connections.....	4
4.1	On/Off (Disconnect) Switch Location .....	4
5.0	Pre Start-Up.....	4
5.1	Prior To Operation .....	4
5.2	General Inspection.....	5
5.3	Check For Refrigerant Leaks .....	5
5.4	Check Cooling Effects.....	5
5.5	Check Heating Effects .....	5
6.0	Operation.....	6
6.1	Operating Instructions.....	6
6.2	Starting Mach-IV .....	6
6.3	Shut Off Mach-IV .....	7
7.0	Maintenance And Service.....	8
7.1	Cleaning.....	8
7.2	Lubrication .....	8
7.3	Condenser-Fan Adjustment.....	8
7.4	Condenser Coil Grille.....	9
7.5	Refrigerant Charge .....	9
8.0	Troubleshooting.....	9
9.0	Parts Lists & Illustrations .....	10

APPENDIX I      MSDS - R-410A Refrigerant

***Additional Documents:***

Carrier Manuals

**Model: 17A7503F7000**  
**Mobile Air Conditioner (MACH-IV) with Heater Option - 208 VAC – 3 Phase – 60 Hz**

REVISION	DATE	TEXT AFFECTED
01	10/2002	Major Revision
02	06/2006	Added Appendix III
03	04/2007	Modified 3.1, 6.2, and Parts Lists
04	12/2007	Removed Electrical Schematic
05	09/2009	Major revision

**Model: 17A7503F7000**  
**Mobile Air Conditioner (MACH-IV) with Heater Option - 208 VAC – 3 Phase – 60 Hz**

This product can not be modified without the written approval of Tronair, Inc. Any modifications done without written approval voids all warranties and releases Tronair, Inc., its suppliers, distributors, employees, or financial institutions from any liability from consequences that may occur. Only Tronair OEM replacement parts shall be used.

**1.0 DESCRIPTION**

The Tronair Model 17A7503F7000 MACH-IV unit (Mobile Air Conditioner/Heater) is a complete portable aircraft ground cooling and heating unit designed for corporate aviation departments, FBO's, and regional/commuter airlines.

The MACH-IV provides pre-cooling or pre-heating prior to passenger arrival, as well as during ramp maintenance work.

The 4 ton air conditioner provides cool air using Puron, environmentally "safe" refrigerant, or warm air using an electric heater, when plugged into 3 phase, 60 Hz, 208 power source.

**2.0 USAGE AND SAFETY INFORMATION**

**2.1 USAGE**

The Tronair Model 17A7503F7000 MACH-IV provides 45,000 Btu/hr of cool air and 27,000 Btu/hr of warm air at 1,200 – 2,000 cfm for aircraft cabin comfort.

**2.2 SAFETY CONSIDERATIONS**

Installation and servicing of air-conditioning equipment can be hazardous due to system pressure and electrical components. Only trained and qualified service personnel should install, repair, or service air-conditioning equipment.

Untrained personnel can perform the basic maintenance functions of cleaning coils and filters and replacing filters. All other operations should be performed by trained service personnel. When working on air-conditioning equipment, observe precautions in the literature, tags and labels attached to the unit, and other safety precautions that may apply.

Follow all safety codes. Wear safety glasses and work gloves. Use quenching cloth for unbrazing operations. Have fire extinguisher available for all brazing operations.

**WARNING!**

**Air conditioner unit must be on a level surface or it may not operate correctly.**



**Before performing service or maintenance operations on unit, turn off main power switch to unit.**

**Electrical shock could cause personal injury.**

**2.3 SAFETY PRECAUTIONS**

To insure safe operations please read the following statements and understand their meaning. Also refer to your equipment manufacturer's manual for other important safety information. This manual contains safety precautions which are explained below. Please read carefully.



**WARNING!** Warning is used to indicate the presence of a hazard that **can cause severe personal injury, death, or substantial property damage** if the warning notice is ignored.

**CAUTION!** Caution is used to indicate the presence of a hazard that **will or can cause minor personal injury or property damage** if the caution notice is ignored.



**Accidental Starts!** Before servicing the equipment, always disconnect the power cord to prevent the air conditioner from starting accidentally. Ground leads to prevent sparks that could cause fires.



**Rotating Parts!** Keep hands, feet, hair, and clothing away from all moving parts to prevent injury. Never operate the air conditioner with covers, shrouds, or guards removed.



**Hot Parts!** Components can get extremely hot from operation. To prevent severe burns, do not touch these areas while the air conditioner is running or immediately after it is turned off. Never operate the air conditioner with heat shields or guards removed.



**Electrical Shock!** Never touch electrical wires or components while the air conditioner is running. They can be sources of electrical shock.

Do not operate air conditioner with cabinet panels removed.

**TRONAIR**

09/2009 – Rev. 05

**Model: 17A7503F7000**  
**Mobile Air Conditioner (MACH-IV) with Heater Option - 208 VAC – 3 Phase – 60 Hz**

**3.0 FEATURES, BENEFITS AND RATINGS**

Every compact one-piece unit arrives fully assembled, charged, tested and ready to run.

**3.1 FEATURES/BENEFITS**

- **Durable, Dependable Construction** – Designed for durability in any climate, the weather-resistant cabinets are constructed of galvanized steel, bonderized, and all exterior panels are coated with a pre painted baked enamel finish. The paint finish is non-chalking, and is capable of withstanding ASTM B117 500-hour Salt Spray Test. All internal cabinet panels are primed, permitting longer life and a more attractive appearance for the entire unit. Totally enclosed condenser-fan motor and permanently lubricated bearings provide additional unit dependability.
- **Proven Compressor Reliability** – Design techniques feature computer-programmed balance between compressor, condenser and evaporator. Carrier-specified hermetic compressors are equipped with compressor over current and over temperature protection to ensure durability.
- **Extra Receptacles** – An external, covered 115 volt Ground Fault Interrupt (GFI) receptacle is provided as a convenient power source for drills, lights, refrigerant recovery units, or other electrical service tools. Simply connect the outlet to a field-supplied and properly fused branch circuit power supply.
- Single 16 kilowatt electric heater
- Pre-coated aluminum fin coil
- High pressure switch
- Loss of charge/low pressure switch
- Freeze protection switch
- Non-corrosive, sloped condensate drain pan, meets ASHRAE 62-89 (IAQ)
- Two inch (2") return-air filters
- Includes exclusive Acutrol™ metering device to precisely control refrigerant flow (preventing slugging and flood-back) while maintaining optimum unit performance.
- The wheels lock with the towbar in the upright and locking position.
- 12 inch diameter x 25 ft long blower hose (with storage compartment), connects quickly and easily to the air conditioning unit. The hose will not fully inflate during the cooling or heating process.
- Unit is designed to cool and/or heat an aircraft through a window or door opening.

**3.2 RATINGS**

**AIR CONDITIONING AND REFRIGERATION INSTITUTE (ARI) CAPACITY RATINGS**

Nominal Tons	Standard CFM	Net Cooling Capacity (Btuh)	Total kW	SEER	Sound Rating (dB)
4	1600	45,000	4.0	13.0	81

**LEGEND**

- Bels** – Sound Levels (1 bel = 10 decibels)                      **kW** – Kilowatt  
**Btuh** – British Thermo unit/hour                                      **SEER** – Seasonal Energy Efficiency Ratio

**NOTES:**

1. Rated in accordance with ARI Standards 270-95
2. Ratings are net values, reflecting the effects of circulating fan heat

**3.3 ELECTRICAL DATA**

**ELECTRICAL DATA**

Nominal V-Ph-Hz	Voltage Range		Compr (each)		OFM			IFM	Electric Heat		Power Supply		Disconnect Size	
	Min	Max	RLA	LRA	Qty	Hp	FLA	FLA	Nominal KW*	FLA	MCA	MOCP ††	FLA	LRA
208-3-60	187	253	13.7	83	1	1/4	1.5	4.9	12.0	33.4	48.3	50	44	117

**LEGEND**

- IFM** – Indoor (Evaporator) Fan Motor                                      **OFM** – Outdoor (Condenser) Fan Motor  
**RLA** – Rated Load Amps    **LRA** – Locked Rotor Amps  
**FLA** – Full Load Amps    **MCA** – Minimum Circuit Amps  
**MOCP** – Maximum Overcurrent Protection                                      **††** – Fuse or HACR Circuit Breaker

\* **Heater Capacity (kW) is based on heater voltage of 208 volts. If power distribution voltage to unit varies from rated heater voltage, heater kW will vary accordingly.**



3.0 FEATURES, BENEFITS AND RATINGS (continued)

3.4 208 VOLT VERSUS 230 VOLT

If the 208-V unit is to be connected to a 230-V power supply, the transformer must be rewired by moving the black wire from the red wire on the transformer and connecting it to the orange wire from the transformer. The end of the red wire must then be insulated. To change these wires, remove the low voltage access panel and the control box access panel. **See Figure 1.**



**WARNING!**

**Plugging a 230 VAC wired air conditioner into a 208 VAC receptacle is not recommended. If this procedure is used, the air conditioner will not run properly; if at all.**

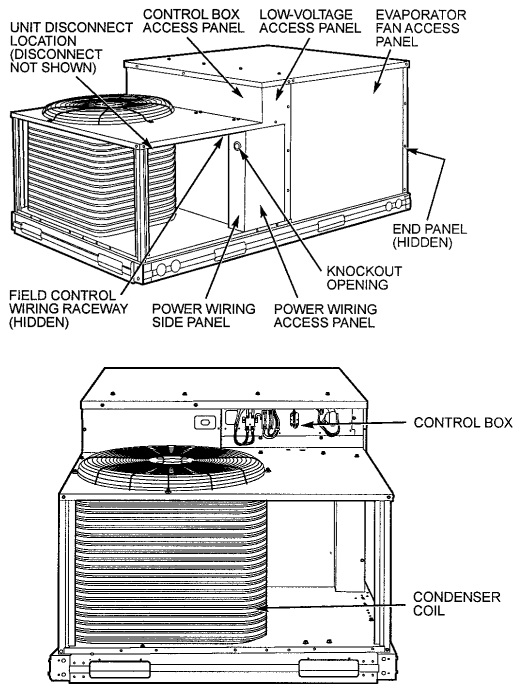

FIGURE 1 – Typical Component Locations

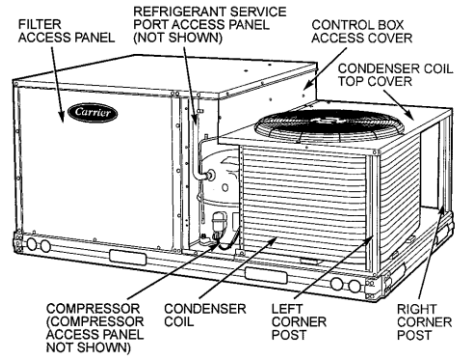

FIGURE 2 – Fan & Motor Assembly

3.5 FIELD POWER SUPPLY

1. Remove evaporator fan access panel (**See Figure 1**). Check fan and belt rotation by turning on disconnect for one to two seconds. **See Figure 2.**
2. If fan is rotating in the wrong direction, switch the power cable lines. An arrow is on the unit.
3. Replace evaporator fan access panel. **See Figure 2.**



**CAUTION!**

**Voltage to compressor terminals during operation must be within voltage range indicated on unit nameplate. On 3 phase units, voltages between phases must be balanced within 2% and the current within 10%. Use the formula shown below to determine the percent of voltage imbalance. Operation on improper line voltage or excessive phase imbalance constitutes abuse and may cause damage to electrical components. Such operation would invalidate any applicable Carrier warranty.**

- NOTES:
1. In compliance with NEC requirements for multi motor and combination load equipment (refer to NEC Articles 430 and 440), the over current protective device for the unit shall be fuse or HACR breaker.
  2. *Unbalanced 3-Phase Supply Voltage* - Never operate a motor where a phase imbalance in supply voltage is greater than 2%. Use the following formula to determine the percent of voltage imbalance:

$$\% \text{ Voltage Imbalance} = 100 \times \frac{\text{max voltage deviation from avg voltage}}{\text{average voltage}}$$

**IMPORTANT: If the supply voltage phase imbalance is more than 2%, contact your local electric utility company immediately.**

3.0 Features, benefits and ratings continued on following page.

### 3.0 FEATURES, BENEFITS AND RATINGS (continued)

#### 3.6 TRAILER

- Welded steel frame construction
- Tapered roller bearings; re-lubricable, sealed
- Wheel: 4 hole, 4 inch bolt circle
- Tires: Size – 4.80 x 8 inch diameter      Pressure – 50 psi (Rear)  
          Size – 4 x 12.6 inch diameter      Pressure – 85 psi (Front)

### 4.0 ELECTRICAL CONNECTIONS



#### CAUTION!

Voltage to compressor terminals during operation must be within voltage range indicated on unit nameplate.

NOTE: In compliance with NEC requirements for multi-motor and combination load equipment (refer to NEC Articles 430 and 440), the over current protective device for the unit shall be fuse or HACR breaker. See section 3.3 Electrical Data for size.



#### WARNING!

- Unit cabinet must have an uninterrupted, unbroken electrical ground to minimize the possibility of personal injury if an electrical fault should occur.
- This ground consists of an electrical wire connected to unit ground lug in control compartment when installed in accordance with NEC (National Electrical Code), ANSI (American National Standards Institute)/NFPA (National Fire Protection Association), latest edition (in Canada, Canadian Electrical Code CSA [Canadian Standards Association] C22. 1) and local electrical codes.
- Failure to follow this warning could result in the installer being liable for personal injury of others.

#### 4.1 ON/OFF (DISCONNECT) SWITCH LOCATION

The On/Off switch (Disconnect) is mounted on the unit under the top panel and behind the condenser coil. **Reference Figure 1 and Figure 3.**

This factory-installed, internally-mounted, NEC (National Electrical Code) and UL (Underwriters' Laboratories) approved non-fused On/Off switch (Disconnect) provides unit power shutoff.

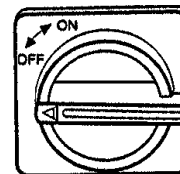

FIGURE 3  
Unit Mounted Disconnect

### 5.0 PRE START-UP

#### 5.1 PRIOR TO OPERATION

Prior to operating the MACH-IV, the user should become familiar with the owner's operating manual.



#### CAUTION!

- Do not jumper any safety devices when operating the unit.
- Do not operate the compressor when the outdoor temperature is below 40° F (4 C) unless accessory low-temperature kit is installed.
- Do not rapid-cycle the compressor. Allow five (5) minutes between "on" cycles to prevent compressor damage.



#### WARNING!

Failure to observe the following warnings could result in serious personal injury:

1. Follow recognized safety practices and wear protective goggles when checking or servicing refrigerant system.
2. Do not operate compressor or provide any electric power to unit unless compressor terminal cover is in place and secured.
3. Do not remove compressor terminal cover until all electrical sources are disconnected.
4. Relieve all pressure from both high- and low-pressure sides of the system before touching or disturbing anything inside terminal box if refrigerate leak is suspected around compressor terminals. Use accepted methods to recover refrigerant.
5. Never attempt to repair soldered connection while refrigerant system is under pressure.
6. Do not use torch to remove any component. System contains oil and refrigerant under pressure. To remove a component, wear protective goggles and proceed as follows:
  - a. Shut off electrical power to unit.
  - b. Relieve all pressure from system using both high- and low-pressure ports. Use accepted methods to recover refrigerant.
  - c. Cut component connecting tubing with tubing cutter and remove component from unit.
  - d. Carefully unsweat remaining tubing stubs when necessary. Oil can ignite when exposed to torch flame.



## 5.0 PRE START-UP *(continued)*

### 5.2 GENERAL INSPECTION

1. Remove all access panels.
2. Read and follow instructions on all WARNING, CAUTION, and INFORMATION labels attached to and/or shipped with unit.
3. Make the following inspections:
  - a. Inspect for shipping and handling damages such as broken lines, loose parts, disconnected wires, etc.
  - b. Inspect for oil at all refrigerant tubing connections and on unit base. Detecting oil generally indicates a refrigerant leak. Leak-test all refrigerant tubing connections using electronic leak detector or liquid-soap solution. If a refrigerant leak is detected, see 5.3 Check for Refrigerant Leaks section.
  - c. Inspect all field and factory wiring connections. Be sure that connections are completed and tight.
  - d. Inspect coil fins. If damaged during shipping and handling, carefully straighten fins with a fin comb.
4. Verify the following conditions:
  - a. Make sure that condenser-fan blade is correctly positioned in fan orifice. Leading edge of blade should be two inches (2 inch/51 mm) from condenser inlet grille and one-half inch (½ in/13mm) from fan deck.
  - b. Make sure that air filter(s) is in place.
  - c. Make sure that condensate drain pan and trap are filled with water to ensure proper drainage.
  - d. Make sure that all tools and miscellaneous loose parts have been removed.

### 5.3 CHECK FOR REFRIGERANT LEAKS

Locate and repair refrigerant leaks and charge the unit as follows:

1. Using both high-pressure and low-pressure ports, locate leaks and recover remaining refrigerant to relieve system pressure.
2. Repair leak following accepted practices.
3. Check system for leaks using an approved method.
4. Evacuate refrigerant system and recover refrigerant if no additional leaks are found.
5. Charge unit with R-410A refrigerant, using a volumetric-charging cylinder or accurate scale. *Refer to unit rating plate for required charge.* Be sure to add extra refrigerant to compensate for internal volume of filter drier.

### 5.4 CHECK COOLING EFFECTS

Plug in unit. Flip Heat/Cool switch to "Cool". Turn On/Off switch to "On" position. Fan should be on and blowing correctly. After approximately 30 seconds, condenser should "kick on". Observe that compressor, condenser fan, and evaporator blower motors start. Observe that cooling cycle shuts down when control setting is satisfied.

### 5.5 CHECK HEATING EFFECTS

Plug in unit. Flip Heat/Cool switch to "Heat". Turn On/Off switch to "On" position. Fan should be on and blowing warm air.

6.0 OPERATION

6.1 OPERATING INSTRUCTIONS

Operate the MACH-IV in accordance with the operating instructions provided on the instrument panel.  
**Reference Figure 5.**

A description of each step of the STARTING and SHUT OFF sequence is given, along with a brief discussion of what is to be expected.

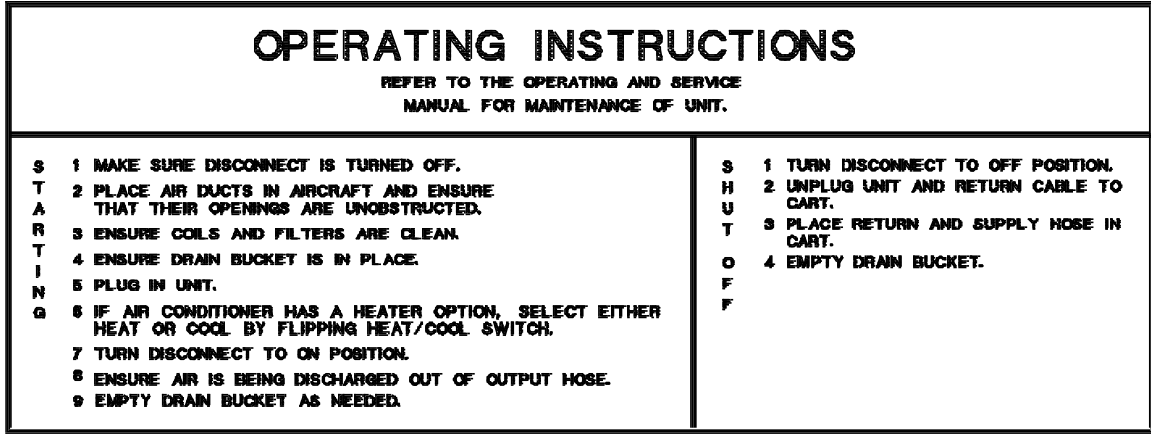

FIGURE 5 - Operating Instructions Label

6.2 STARTING MACH-IV

1. Ensure On/Off switch (Disconnect) is turned to "Off" position. The On/Off (Disconnect) switch is "Off" when turned counter-clockwise. **Reference Figure 3.**



**WARNING!**

Until ready for use, always leave this switch in the "Off" position.

2. Place air duct in aircraft and ensure that the opening is unobstructed. Remove yellow output air duct from the storage compartment located under the unit. Remove yellow dust caps from the input and output duct openings located on the back of the air conditioner and place in the storage compartments. Attach yellow output air duct to the air conditioner via the duct opening located on the back of the air conditioner. **See Figure 6.** Place other end of yellow duct into the aircraft.
3. Ensure coils and filters are clean. Refer to section 7.1 Cleaning in this manual.
4. Ensure drain bucket is in place. The MACH-IV unit does not have a factory supplied drain bucket. Depending on your usage, a drain bucket or any condensate collector device may not be needed. Below are two suggestions you may utilize if you do not want the condensation to collect on the floor/ramp:
  - a. Purchase a bucket with a lid on it and the lid has at least a 13/16 inch diameter hole. The hole in the bucket will receive the 3/4 inch diameter yellow condensate hose coming out of the MACH-IV unit.
  - b. Buy a 1/2 inch diameter male garden hose coupler and attach it to the end of the 3/4 inch diameter yellow condensate hose coming out of the MACH-IV unit. Also, purchase any length garden hose to attach to the 1/2 inch diameter garden hose coupler. By doing the above, you will be able to direct the condensate to any location.

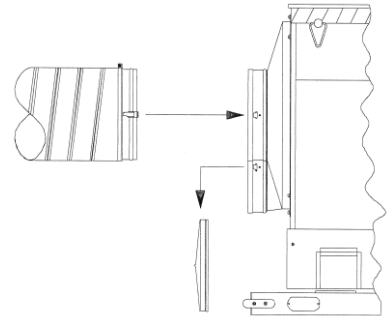

FIGURE 6



**WARNING!**

The end of the garden hose can not be higher than the condensate trap located under the air conditioning unit. Damage to equipment and/or electrical shock may occur.

5. Plug in unit. The MACH-IV unit does not come factory supplied with a plug. Purchase a plug according to the receptacle. See section 4.0 Electrical Connections for important instructions concerning electrical connections.



**WARNING!**

Plugging a 230 VAC wired air conditioner into a 208 VAC receptacle is not recommended. If this procedure is used, the air conditioner will not run properly; if at all. See section 3.4.

**Model: 17A7503F7000**  
**Mobile Air Conditioner (MACH-IV) with Heater Option - 208 VAC – 3 Phase – 60 Hz**

6.2 STARTING MACH-IV (*continued*)

6. Locate the Heat/Cool switch in front of the air conditioner unit near the power cord. See **Figure 7**. Move switch up or down to the desired function of either heating or cooling.

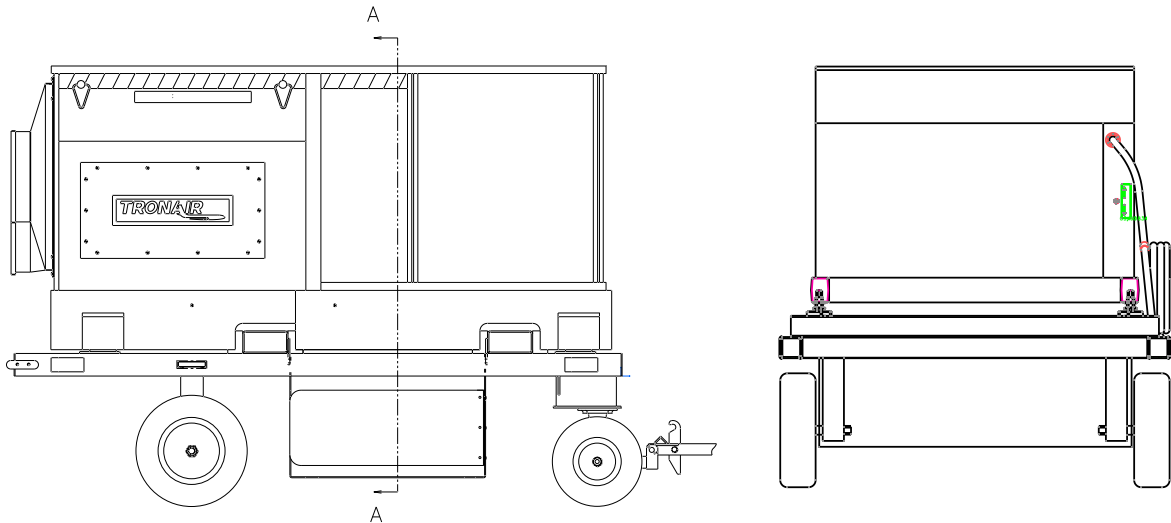

**FIGURE 7**

7. Turn On/Off switch (Disconnect) to "On" position. Turn On/Off switch (Disconnect) to "On" position by turning clockwise. See **Figure 3**.
8. **Cooling:** Check supply air duct to ensure cool air is being discharged when condenser is on. When unit is turned "On" and the Heat/Cool switch is in the "Cool" position, the evaporator blower fan located inside the fan access panel (Reference **Figure 1**) begins rotating. After approximately 30 seconds, the compressor and condenser fan "kicks on". These two items will continue to function until a temperature of 55° F is reached inside the air conditioner unit.

When a temperature of approximately 60° F is reached, the compressor and condenser fan will cycle back on. At no time will the evaporator blower fan cease to operate as long as the On/Off (Disconnect) switch is in the "On" position.

**Heating:** Check supply air duct to ensure warm air is being discharged when the heater is on.

When unit is turned on and the Heat/Cool switch is in the "Heat" position, the evaporator blower fan located inside the fan access panel (**Reference Figure 1**) begins rotating and the electric heater starts. When a temperature of 76° F is reached inside the air conditioner unit, the heater will shut off. At no time will the evaporator blower fan cease to operate as long as the On/Off (Disconnect) switch is in the "On" position.

**NOTE:** If the unit has been sitting for an extended amount of time without use and/or after considerable moving of unit (especially during shipping), the first 30 second delay may be as long as five (5) minutes due to removal of excessive pressure build-up against the head of the compressor.

If a temperature of less than 50° F is obtained, the freeze protection switch will open and the air conditioner unit will not function until the freeze protection switch is reset.

9. Empty drain bucket as needed to keep condensate from collecting on the floor/ramp.

6.3 SHUT OFF MACH-IV

1. Turn Disconnect to "Off" position. The On/Off (Disconnect) switch is "Off" when turned counter-clockwise. **Reference Figure 3**.
2. Place return and supply hose in cart.
3. Unplug unit and return cable to cart. The cable hanger is located on the side of the unit. Ensure the cable does not touch the ground.
4. Empty drain bucket.

## 7.0 MAINTENANCE AND SERVICE

### CAUTION!



When servicing unit, shut off all electrical power to unit to avoid shock hazard or injury from rotating parts.

### 7.1 CLEANING

Inspect unit interior at the beginning of each heating and cooling season or as operating conditions require.

Evaporator Coil - Inspect and clean coil prior to each heating and cooling season, and as required by location.

1. Turn unit power off.
2. Slide filters (located in the hinged access panel) out of unit.  
Replace if dirty. See Figure 8.

NOTE: This panel permits quick and simple filter access and prevents panels from being dropped.

3. Clean coil using a commercial coil cleaner or dishwasher detergent in a pressurized spray canister. Wash both sides of coil and flush with clean water. For best results, back flush toward return-air section to remove foreign material.
4. Flush condensate pan.
5. Re-install filters.
6. Re-connect wiring.
7. Close filter-hinged access panel.

**Condenser Coil** – Inspect coil monthly. Clean condenser coil annually, and as required by location and outdoor air conditions.

**One-Row Coils** – To access one-row coils, remove screws securing condenser-fan grille to condenser coil top cover. Place grille on top of condenser coil top cover as shown in Figure 9. It is not necessary to remove the top cover.

**One-Row Coils** – Use a water hose or other suitable equipment to remove dirt and debris. Clean the outer surfaces with a stiff brush in the normal manner.

Reverse the procedure outlined above to re-install the condenser-fan grille and condenser fan top cover.

**Condensate Drain** – Check and clean each year at start of cooling season. In winter, keep drain dry or protect against freeze-up. Condensate drain and tray are located on the bottom of the air conditioner.

**Filters** – Clean or replace at start of each heating and cooling season, or more often if operating conditions require it. Replacement filters must be same dimensions as original filters.

### 7.2 LUBRICATION

Compressors – Each compressor is charged with the correct amount of oil at the factory.

Fan-Motor Bearings – Fan-motor bearings are of the permanently lubricated type. No further lubrication is required. No lubrication of condenser or evaporator-fan motors is required.

### 7.3 CONDENSER-FAN ADJUSTMENT

1. Shut off unit power supply.
2. Remove condenser-fan assembly (grille, motor, and fan).
3. Loosen fan hub setscrews.
2. Adjust fan height as shown in *Figure 10*.
3. Tighten setscrews.
4. Replace condenser-fan assembly.

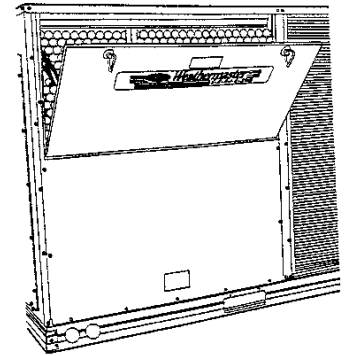

FIGURE 8  
Filter Hinged Access Panel

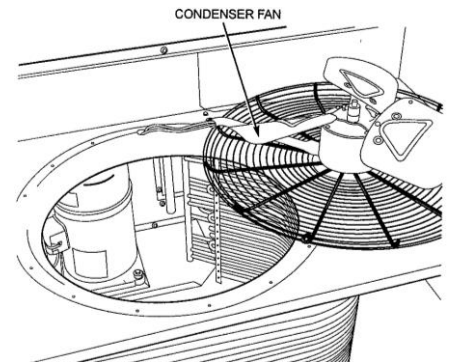

FIGURE 9  
Condenser Coil Cleaning

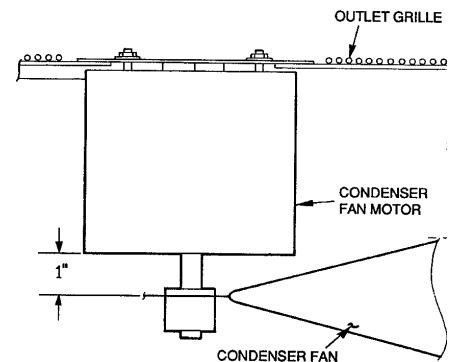

FIGURE 10  
Condenser Fan Adjustment

**7.0 MAINTENANCE AND SERVICE** *(continued)*

**7.4 CONDENSER COIL GRILLE**

Condenser coil grille is shipped factory installed. No adjustments are required.

**7.5 REFRIGERANT CHARGE**

Amount of refrigerant charge is listed on unit nameplate. Refer to Carrier Charging, Recovery, Recycling, and Reclamation training manual.

Unit panels must be in place when unit is operating during charging procedure.

No Charge – Use standard evacuating techniques. After evacuating system, weigh in the specified amount of refrigerant.

**8.0 TROUBLESHOOTING**

Refer to Troubleshooting Tables and **Figure 10** for additional information.

**TABLE – COOLING SERVICE ANALYSIS**

Problem	Cause	Remedy
Compressor and condenser fan will not start.	Power failure.	Call power company.
	Fuse blown or circuit breaker tripped.	Replace fuse or reset circuit breaker.
	Defective thermostat, contactor, transformer, or control relay.	Replace component.
	Insufficient line voltage.	Determine cause and correct.
	Incorrect or faulty wiring.	Check wiring diagram and rewire correctly.
	Thermostat setting too high.	Lower thermostat setting below room temperature.
Compressor will not start but condenser fan runs.	Faulty wiring or loose connections in compressor circuit.	Check wiring and repair or replace.
	Compressor motor burned out, seized, or internal overload open.	Determine cause. Replace compressor.
	Defective run/start capacitor, overload, start relay.	Determine cause and replace.
	One leg of three-phase power dead.	Replace fuse or reset circuit breaker.
Compressor cycles (other than normally satisfying thermostat).	Refrigerant overcharge or undercharge.	Recover refrigerant, evacuate system, and recharge to nameplate.
	Defective compressor.	Replace and determine cause.
	Insufficient line voltage.	Determine cause and correct.
	Blocked condenser.	Determine cause and correct.
	Defective run/start capacitor, overload, or start relay.	Determine cause and replace.
	Defective thermostat.	Replace thermostat.
	Faulty condenser-fan motor or capacitor.	Replace.
Restriction in refrigerant system.	Locate restriction and remove.	
Compressor operates continuously.	Dirty air filter.	Replace filter.
	Unit undersized for load.	Decrease load or increase unit size
	Thermostat set too low.	Reset thermostat.
	Low refrigerant charge.	Locate leak; repair and recharge.
	Leaking valves in compressor.	Replace compressor.
	Air in system.	Recover refrigerant, evacuate system, and recharge.
	Condenser coil dirty or restricted.	Clean coil or remove restriction

8.0 Trouble shooting continued on following page.



**8.0 TROUBLESHOOTING** *(continued)*

Refer to Troubleshooting Tables and **Figure 10** for additional information.

**TABLE – COOLING SERVICE ANALYSIS**

Problem	Cause	Remedy
Excessive head pressure	Dirty air filter.	Replace filter.
	Dirty condenser coil.	Clean coil.
	Refrigerant overcharged.	Recover excess refrigerant.
	Air in system.	Recover refrigerant, evacuate system, and recharge.
	Condenser air restricted or air short-cycling.	Determine cause and correct.
Head pressure too low.	Low refrigerant charge.	Check for leaks; repair and recharge.
	Compressor valves leaking.	Replace compressor.
	Restriction in liquid tube.	Remove restriction.
Excessive suction pressure.	High head load.	Check for source and eliminate.
	Compressor valves leaking.	Replace compressor.
	Refrigerant overcharged.	Recover excess refrigerant.
Suction pressure too low.	Dirty air filter.	Replace filter.
	Low refrigerant charge.	Check for leaks; repair and recharge.
	Metering device or low-side restricted.	Remove source of restriction.
	Insufficient evaporator airflow.	Increase air quantity. Check filter and replace if necessary.
	Temperature too low in conditioned area.	Reset thermostat.
	Outdoor ambient below 25° F.	Install low-ambient kit.

**9.0 PARTS LISTS & ILLUSTRATIONS**

Reference Parts List for available Replacement Parts and Kits.

### Parts List

When ordering replacement parts/kits, please specify model, serial number and color of your unit.

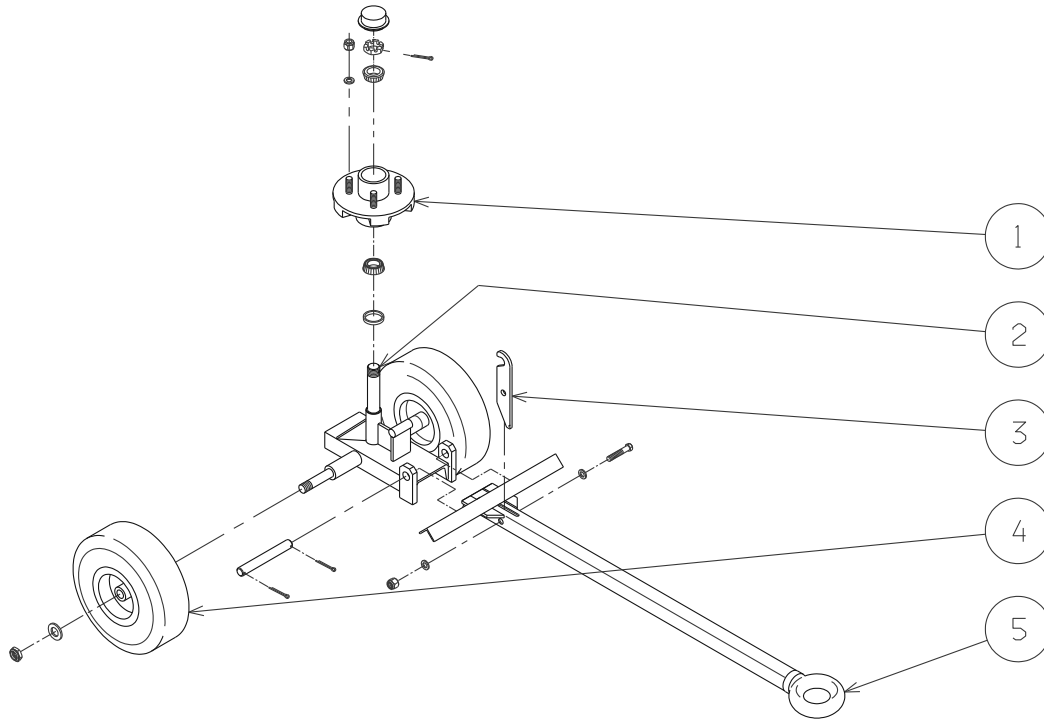

ITEM	PART NUMBER	DESCRIPTION	QTY
1	H-1335	Hub	1
2	Z-2449-01	Weldment, Steering Axle	1
3	<b>K-1320</b>	<b>Kit, Lever; consists of:</b>	
	G-1100-109522	Bolt, Hex Head, Grade 5, 1/2-20 x 2-1/4" long	1
	G-1202-1090N	Stopnut 1/2-20 Elastic	1
	G-1250-1090N	Flatwasher, 1/2 Narrow	2
	J-1626	Lever	1
4	<b>K-2084</b>	<b>Kit, Wheel (Single); consists of:</b>	
	G-1203-1115	Stopnut, 3/4-16 Elastic	1
	U-1041	Wheel, Pneumatic Tire	1
5	<b>K-3361</b>	<b>Kit, Tongue; consists of:</b>	
	G-1301-03	Pin, Cotter (1/8" diameter x 1-1/2" long)	2
	R-1122	Pin	1
	Z-4838-01	Weldment, Tongue	1

### Parts List

When ordering replacement parts/kits, please specify model, serial number and color of your unit.

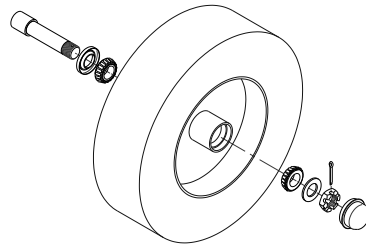
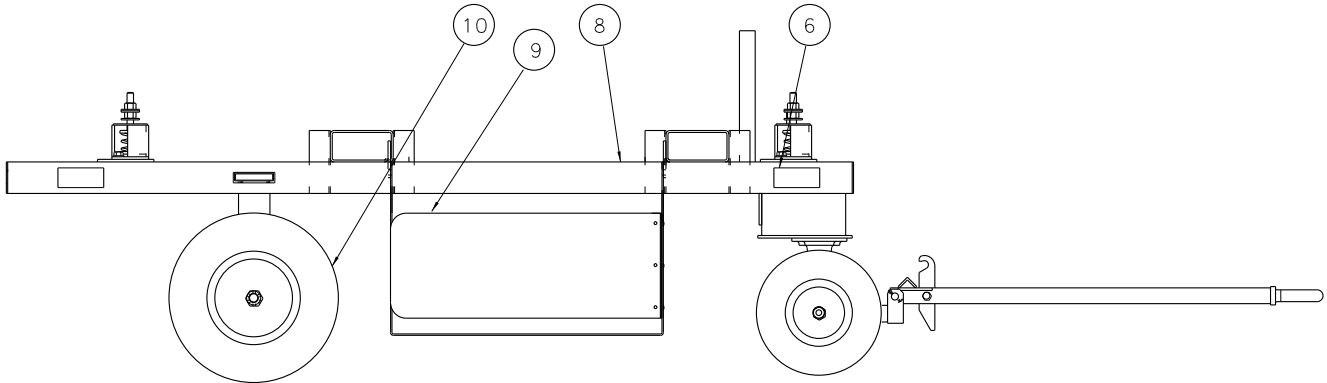

ITEM 10 DETAIL

ITEM	PART NUMBER	DESCRIPTION	QTY
8.....	Z-4734-01.....	Weldment, Frame.....	1
10.....	Z-1217.....	Assembly, Wheel, Tire & Bearing.....	1
6.....	<b>K-3344</b> .....	<b>Kit, Isolator; consists of:</b>	
	G-1100-109514.....	Bolt, Hex Head, Grade 5, 1/2-20 x 1-1/2" long.....	2
	G-1202-1090N.....	Stopnut 1/2-20 Elastic.....	4
	G-1250-1090N.....	Flatwasher, 1/2 Narrow.....	2
	H-2396.....	Isolator.....	1
9.....	<b>K-4120</b> .....	<b>Kit, Vent Hose Holder</b> .....	1



### Parts List

When ordering replacement parts/kits, please specify model, serial number and color of your unit.

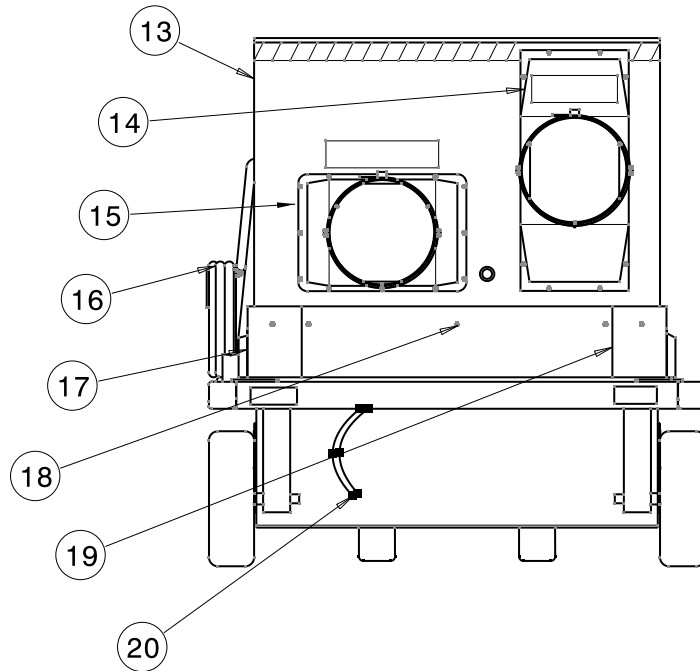

ITEM	PART NUMBER	DESCRIPTION	QTY
13.....	H-2361.....	Air Conditioner .....	1
14.....	Z-6592.....	Assembly, Clamp .....	1
15.....	Z-6591.....	Assembly, Clamp .....	1
20.....	Z-4733.....	Assembly, Drain .....	1
Not Shown.....	H-3003.....	Hose, Insulated Vent.....	1
Not Shown.....	H-2459.....	Filter, Air Conditioner (16" x 25" x 2").....	1
<b>16.....</b>	<b>K-3348.....</b>	<b>Kit, Electrical Cable; consists of:</b>	
.....	EC-1176-04.....	Locknut, Conduit .....	1
.....	EC-1433-21.....	Connector, Strain Relief .....	1
.....	EC-1507-02*0600.....	Cable, Type 50 Electrical 600 V, 50 ft long .....	1
.....	G-1159-105010.....	Screw, Round Head Cross Recess Machine 1/4-20 x 1" long .....	1
.....	G-1202-1050.....	Stopnut, 1/4-20 Elastic .....	1
.....	G-1250-1050N.....	Flatwasher, 1/4 Narrow .....	2
.....	H-1721-10.....	Clamp, Electrical .....	1
<b>17.....</b>	<b>K-3349.....</b>	<b>Kit, Right Hand Shroud; consists of:</b>	
.....	G-1189.....	Screw, Hex Washer Head, #10 x 3/4" long .....	7
.....	S-1666-01.....	Shroud.....	1
.....	S-1667-01.....	Shroud.....	1
<b>18.....</b>	<b>K-3351.....</b>	<b>Kit, Front or Back Shroud; consists of:</b>	
.....	G-1189.....	Screw, Hex Washer Head, #10 x 3/4" long .....	3
.....	S-1663-01.....	Shroud.....	1
<b>19.....</b>	<b>K-3350.....</b>	<b>Kit, Left Hand Shroud; consists of:</b>	
.....	G-1189.....	Screw, Hex Washer Head, #10 x 3/4" long .....	7
.....	S-1664-01.....	Shroud.....	1
.....	S-1665-01.....	Shroud.....	1





**APPENDIX I**

**MSDS  
(R-410A Refrigerant)**



## Material Safety Data Sheet

### Genetron® AZ-20 (R-410A)

#### 1. CHEMICAL PRODUCT AND COMPANY IDENTIFICATION

**PRODUCT NAME:** Genetron® AZ-20 (R-410A)  
**OTHER/GENERIC NAMES:** R-410A  
**PRODUCT USE:** Refrigerant  
**MANUFACTURER:** Honeywell  
101 Columbia Road  
Box 1053  
Morristown, New Jersey 07962-1053

**FOR MORE INFORMATION CALL:**  
(Monday-Friday, 9:00am-5:00pm)  
1-800-522-8001

**IN CASE OF EMERGENCY CALL:**  
(24 Hours/Day, 7 Days/Week)  
1-800-707-4555 or  
Chemtrec- 1-800-424-9300

#### 2. COMPOSITION/INFORMATION ON INGREDIENTS

<u>INGREDIENT NAME</u>	<u>CAS NUMBER</u>	<u>WEIGHT %</u>
Difluoromethane	75-10-5	50
Pentafluoroethane	354-33-6	50

Trace impurities and additional material names not listed above may also appear in Section 15 toward the end of the MSDS. These materials may be listed for local "Right-To-Know" compliance and for other reasons.

#### 3. HAZARDS IDENTIFICATION

**EMERGENCY OVERVIEW:** Colorless, volatile liquid with ethereal and faint sweetish odor. Non-flammable material. Overexposure may cause dizziness and loss of concentration. At higher levels, CNS depression and cardiac arrhythmia may result from exposure. Vapors displace air and can cause asphyxiation in confined spaces. At higher temperatures, (>250° C), decomposition products may include Hydrofluoric Acid (HF) and carbonyl halides

#### POTENTIAL HEALTH HAZARDS

**SKIN:** Irritation would result from a defatting action on tissue. Liquid contact could cause frostbite.

**EYES:** Liquid contact can cause severe irritation and frostbite. Mist may irritate.

**INHALATION:** Genetron AZ-20 (R-410A) is low in acute toxicity in animals. When oxygen levels in air are reduced to 12–14% by displacement, symptoms of asphyxiation, loss of coordination, increased pulse rate and deeper respiration will occur. At high levels, cardiac arrhythmia may occur.

---

## MATERIAL SAFETY DATA SHEET Genetron® AZ-20 (R-410A)

---

**INGESTION:** Ingestion is unlikely because of the low boiling point of the material. Should it occur, discomfort in the gastrointestinal tract from rapid evaporation of the material and consequent evolution of gas would result. Some effects of inhalation and skin exposure would be expected.

**DELAYED EFFECTS:** None known

**Ingredients found on one of the OSHA designated carcinogen lists are listed below.**

<u>INGREDIENT NAME</u>	<u>NTP STATUS</u>	<u>IARC STATUS</u>	<u>OSHA LIST</u>
No ingredients listed in this section			

---

### **4. FIRST AID MEASURES**

---

**SKIN:** Promptly flush skin with water until all chemical is removed. If there is evidence of frostbite, bathe (do not rub) with lukewarm (not hot) water. If water is not available, cover with a clean, soft cloth or similar covering. Get medical attention if symptoms persist.

**EYES:** Immediately flush eyes with large amounts of water for at least 15 minutes (in case of frostbite water should be lukewarm, not hot) lifting eyelids occasionally to facilitate irrigation. Get medical attention if symptoms persist.

**INHALATION:** Immediately remove to fresh air. If breathing has stopped, give artificial respiration. Use oxygen as required, provided a qualified operator is available. Get medical attention. Do not give epinephrine (adrenaline).

**INGESTION:** Ingestion is unlikely because of the physical properties and is not expected to be hazardous. Do not induce vomiting unless instructed to do so by a physician.

**ADVICE TO PHYSICIAN:** Because of the possible disturbances of cardiac rhythm, catecholamine drugs, such as epinephrine, should be used with special caution and only in situations of emergency life support. Treatment of overexposure should be directed at the control of symptoms and the clinical conditions.

---

### **5. FIRE FIGHTING MEASURES**

---

#### FLAMMABLE PROPERTIES

**FLASH POINT:** Gas, not applicable per DOT regulations  
**FLASH POINT METHOD:** Not applicable  
**AUTOIGNITION TEMPERATURE:** >750° C  
**UPPER FLAME LIMIT (volume % in air):** None by ASTM D-56-82  
**LOWER FLAME LIMIT (volume % in air):** None by ASTM E-681  
**FLAME PROPAGATION RATE (solids):** Not applicable  
**OSHA FLAMMABILITY CLASS:** Not applicable

#### **EXTINGUISHING MEDIA:**

Use any standard agent – choose the one most appropriate for type of surrounding fire (material itself is not flammable)

---

## MATERIAL SAFETY DATA SHEET Genetron® AZ-20 (R-410A)

---

### **UNUSUAL FIRE AND EXPLOSION HAZARDS:**

Genetron AZ-20 (R-410A) is not flammable at ambient temperatures and atmospheric pressure. However, this material will become combustible when mixed with air under pressure and exposed to strong ignition sources. Contact with certain reactive metals may result in formation of explosive or exothermic reactions under specific conditions (e.g. very high temperatures and/or appropriate pressures).

### **SPECIAL FIRE FIGHTING PRECAUTIONS/INSTRUCTIONS:**

Firefighters should wear self-contained, NIOSH-approved breathing apparatus for protection against possible toxic decomposition products. Proper eye and skin protection should be provided. Use water spray to keep fire-exposed containers cool.

---

## **6. ACCIDENTAL RELEASE MEASURES**

---

### **IN CASE OF SPILL OR OTHER RELEASE:**

(Always wear recommended personal protective equipment.)

Evacuate unprotected personnel. Protected personnel should remove ignition sources and shut off leak, if without risk, and provide ventilation. Unprotected personnel should not return until air has been tested and determined safe, including low-lying areas.

**Spills and releases may have to be reported to Federal and/or local authorities. See Section 15 regarding reporting requirements.**

---

## **7. HANDLING AND STORAGE**

---

### **NORMAL HANDLING:**

(Always wear recommended personal protective equipment.)

Avoid breathing vapors and liquid contact with eyes, skin or clothing. Do not puncture or drop cylinders, expose them to open flame or excessive heat. Use authorized cylinders only. Follow standard safety precautions for handling and use of compressed gas cylinders.

Genetron AZ-20 (R-410A) should not be mixed with air above atmospheric pressure for leak testing or any other purpose.

### **STORAGE RECOMMENDATIONS:**

Store in a cool, well-ventilated area of low fire risk and out of direct sunlight. Protect cylinder and its fittings from physical damage. Storage in subsurface locations should be avoided. Close valve tightly after use and when empty.

---

## **8. EXPOSURE CONTROLS/PERSONAL PROTECTION**

---

### **ENGINEERING CONTROLS:**

Provide local ventilation at filling zones and areas where leakage is probable. Mechanical (general) ventilation may be adequate for other operating and storage areas.

### **PERSONAL PROTECTIVE EQUIPMENT**

#### **SKIN PROTECTION:**

Skin contact with refrigerant may cause frostbite. General work clothing and gloves (leather) should provide adequate protection. If prolonged contact with the liquid or gas is anticipated, insulated gloves constructed of PVA, neoprene or butyl rubber should be used. Any contaminated clothing should be promptly removed and washed before reuse.

## MATERIAL SAFETY DATA SHEET Genetron® AZ-20 (R-410A)

### EYE PROTECTION:

For normal conditions, wear safety glasses. Where there is reasonable probability of liquid contact, wear chemical safety goggles.

### RESPIRATORY PROTECTION:

None generally required for adequately ventilated work situations. For accidental release or non-ventilated situations, or release into confined space, where the concentration may be above the PEL of 1,000 ppm, use a self-contained, NIOSH - approved breathing apparatus or supplied air respirator. For escape: use the former or a NIOSH-approved gas mask with organic vapor canister.

### ADDITIONAL RECOMMENDATIONS:

Where contact with liquid is likely, such as in a spill or leak, impervious boots and clothing should be worn. High dose-level warning signs are recommended for areas of principle exposure. Provide eyewash stations and quick-drench shower facilities at convenient locations. For tank cleaning operations, see OSHA regulations, 29 CFR 1910.132 and 29 CFR 1910.133.

### EXPOSURE GUIDELINES

<u>INGREDIENT NAME</u>	<u>ACGIH TLV</u>	<u>OSHA PEL</u>	<u>OTHER LIMIT</u>
Difluoromethane	None	None	*1000 ppm TWA (8hr)
Pentafluoroethane	None	None	**1000 ppm TWA (8hr)

\* = Limit established by Honeywell.

\*\* = Workplace Environmental Exposure Level (AIHA).

\*\*\* = Biological Exposure Index (ACGIH).

### OTHER EXPOSURE LIMITS FOR POTENTIAL DECOMPOSITION PRODUCTS:

Hydrogen Fluoride: ACGIH TLV: 3 ppm ceiling

### 9. PHYSICAL AND CHEMICAL PROPERTIES

**APPEARANCE:** Clear, colorless liquid and vapor

**PHYSICAL STATE:** Gas at ambient temperatures

**MOLECULAR WEIGHT:** 72.6

**CHEMICAL FORMULA:** CH<sub>2</sub>F<sub>2</sub>

CHF<sub>2</sub>CF<sub>3</sub>

**ODOR:** Faint ethereal odor

**SPECIFIC GRAVITY (water = 1.0):** 1.08 @ 21.1° C (70° F)

**SOLUBILITY IN WATER (weight %):** Unknown

**pH:** Neutral

**BOILING POINT:** -48.5° C (-55.4° F)

**FREEZING POINT:** Not Determined

**VAPOR PRESSURE:** 215.3 psia @ 70° F

490.2 psia @ 130° F

**VAPOR DENSITY (air = 1.0):** 3.0



## MATERIAL SAFETY DATA SHEET Genetron<sup>®</sup> AZ-20 (R-410A)

**EVAPORATION RATE:** >1 **COMPARED TO:** CCl<sub>4</sub> = 1  
**% VOLATILES:** 100  
**FLASH POINT:** Not applicable  
(Flash point method and additional flammability data are found in Section 5.)

### 10. STABILITY AND REACTIVITY

#### **NORMALLY STABLE? (CONDITIONS TO AVOID):**

The product is stable.  
Do not mix with oxygen or air above atmospheric pressure. Any source of high temperature, such as lighted cigarettes, flames, hot spots or welding may yield toxic and/or corrosive decomposition products.

#### **INCOMPATIBILITIES:**

(Under specific conditions: e.g. very high temperatures and/or appropriate pressures) – Freshly abraded aluminum surfaces (may cause strong exothermic reaction). Chemically active metals: potassium, calcium, powdered aluminum, magnesium and zinc.

#### **HAZARDOUS DECOMPOSITION PRODUCTS:**

Halogens, halogen acids and possibly carbonyl halides.

#### **HAZARDOUS POLYMERIZATION:**

Will not occur.

### 11. TOXICOLOGICAL INFORMATION

#### **IMMEDIATE (ACUTE) EFFECTS:**

LC<sub>50</sub> : 4 hr. (rat) - ≥ 520,000 ppm (difluoromethane)  
Cardiac Sensitization threshold (dog) ≥ 100,000 ppm (pentafluoroethane)

#### **DELAYED (SUBCHRONIC AND CHRONIC) EFFECTS:**

Teratology - negative  
Subchronic inhalation (rat) NOEL - 50,000 ppm

#### **OTHER DATA:**

Not active in four genetic studies

### 12. ECOLOGICAL INFORMATION

**Degradability (BOD):** Genetron AZ-20 (R-410A) is a gas at room temperature; therefore, it is unlikely to remain in water.

**Octanol Water Partition Coefficient:** Log P<sub>ow</sub> = 1.48 (pentafluoroethane), 0.21 (difluoromethane)

### 13. DISPOSAL CONSIDERATIONS

#### **RCRA**

**Is the unused product a RCRA hazardous waste if discarded?** Not a hazardous waste  
**If yes, the RCRA ID number is:** Not applicable

---

**MATERIAL SAFETY DATA SHEET**  
**Genetron® AZ-20 (R-410A)**

---

**OTHER DISPOSAL CONSIDERATIONS:**

Disposal must comply with federal, state, and local disposal or discharge laws. Genetron AZ-20 (R-410A) is subject to U.S. Environmental Protection Agency Clean Air Act Regulations Section 608 in 40 CFR Part 82 regarding refrigerant recycling.

The information offered here is for the product as shipped. Use and/or alterations to the product such as mixing with other materials may significantly change the characteristics of the material and alter the RCRA classification and the proper disposal method.

---

**14. TRANSPORT INFORMATION**

---

**US DOT HAZARD CLASS:** US DOT PROPER SHIPPING NAME: Liquefied gas, n.o.s. (Pentafluoroethane, Difluoromethane)  
US DOT HAZARD CLASS: 2.2  
US DOT PACKING GROUP: Not applicable

**US DOT ID NUMBER:** UN3163

For additional information on shipping regulations affecting this material, contact the information number found in Section 1.

---

**15. REGULATORY INFORMATION**

---

**TOXIC SUBSTANCES CONTROL ACT (TSCA)**

**TSCA INVENTORY STATUS:** Components listed on the TSCA inventory

**OTHER TSCA ISSUES:** None

**SARA TITLE III/CERCLA**

"Reportable Quantities" (RQs) and/or "Threshold Planning Quantities" (TPQs) exist for the following ingredients.

<u>INGREDIENT NAME</u>	<u>SARA/CERCLA RQ (lb.)</u>	<u>SARA EHS TPQ (lb.)</u>
No ingredients listed in this section		

**Spills or releases resulting in the loss of any ingredient at or above its RQ requires immediate notification to the National Response Center [(800) 424-8802] and to your Local Emergency Planning Committee.**

**SECTION 311 HAZARD CLASS:** IMMEDIATE  
PRESSURE

**SARA 313 TOXIC CHEMICALS:**

The following ingredients are SARA 313 "Toxic Chemicals". CAS numbers and weight percents are found in Section 2.

<u>INGREDIENT NAME</u>	<u>COMMENT</u>
No ingredients listed in this section	

---

**MATERIAL SAFETY DATA SHEET**  
**Genetron® AZ-20 (R-410A)**

---

**STATE RIGHT-TO-KNOW**

In addition to the ingredients found in Section 2, the following are listed for state right-to-know purposes.

<u>INGREDIENT NAME</u>	<u>WEIGHT %</u>	<u>COMMENT</u>
No ingredients listed in this section		

**ADDITIONAL REGULATORY INFORMATION:**

Genetron AZ-20 (R-410A) is subject to U.S. Environmental Protection Agency Clean Air Act Regulations at 40 CFR Part 82.

**WARNING:** Contains pentafluoroethane (HFC-125) and difluoromethane (HFC-32), greenhouse gases which may contribute to global warming

**Do Not vent** to the atmosphere. To comply with provisions of the U.S. Clean Air Act, any residual must be recovered.

**WHMIS CLASSIFICATION (CANADA):**

This product has been evaluated in accordance with the hazard criteria of the CPR and the MSDS contains all the information required by the CPR.

**FOREIGN INVENTORY STATUS:**

EU – EINECS # 2065578 (HFC-125)

---

**16. OTHER INFORMATION**

---

**CURRENT ISSUE DATE:** February, 2003

**PREVIOUS ISSUE DATE:** January, 2000

**CHANGES TO MSDS FROM PREVIOUS ISSUE DATE ARE DUE TO THE FOLLOWING:**

Section 1: Updated contact information

**OTHER INFORMATION:** HMIS Classification: Health – 1, Flammability – 1, Reactivity – 0  
NFPA Classification: Health – 2, Flammability – 1, Reactivity – 0  
ANSI/ASHRAE 34 Safety Group – A1

Regulatory Standards:

1. OSHA regulations for compressed gases: 29 CFR 1910.101
2. DOT classification per 49 CFR 172.101

Toxicity information per PAFT Testing