

Model: 18-4314-9800
Four Bottle Nitrogen Cart
Manifold/Regulator and
Nitrogen Blow Out System



06/2012 - Rev. 01



****CAUTION****

It is **MANDATORY** that this instruction manual be read and understood by all persons operating this nitrogen cart.

REVISION
01

DATE
06/2012

TEXT AFFECTED
Original release

TABLE OF CONTENTS

	<u>PAGE</u>
1.0 GENERAL DESCRIPTION	1
2.0 SPECIFICATIONS/FEATURES.....	1
3.0 SAFETY INSTRUCTIONS	2
3.1 GENERAL	2
3.2 SAFETY	2
4.0 PREPARATION FOR USE/ASSEMBLY INSTRUCTION.....	2
5.0 OPERATION OF NITROGEN CART	3
5.1 GENERAL SAFETY REQUIREMENTS	3
5.2 BOTTLE CONNECTION INSTRUCTIONS	3
5.3 TO READ INDIVIDUAL BOTTLE PRESSURE.....	3
5.4 EFFICIENT USE OF SYSTEM.....	4
5.5 NITROGEN SYSTEM CONNECTION.....	5
5.6 AIRCRAFT NITROGEN SYSTEM (Low Pressure).....	5
5.7 DISCONNECT LOW PRESSURE.....	5
6.0 MAINTENANCE	5
6.1 STORAGE.....	5
7.0 GUARANTEES/LIMITATION OF LIABILITY	6

APPENDIX I	Smith Installation & Operator's Guide
APPENDIX II	Instrument Certification Notice
APPENDIX III	Declaration of Conformity

This product can not be modified without the written approval of Tronair, Inc. Any modifications done without written approval voids all warranties and releases Tronair, Inc., its suppliers, distributors, employees, or financial institutions from any liability from consequences that may occur. Only Tronair OEM replacement parts shall be used.

**CAUTION!**

It is **MANDATORY** that this instruction manual be read and understood by all persons operating this nitrogen cart.

1.0 GENERAL DESCRIPTION

The Tronair Four Bottle Cart is designed to transport Nitrogen bottles which are used in the aviation industry. The system contains two regulators. The low pressure regulator is for operating and servicing needs of 0 – 500 psi (34.5 bar).

The second low pressure regulator regulates the pressure to the aircraft and checks the hydraulic system for leaks prior to filling with hydraulic fluid.

**WARNING!**

To Avoid Serious Injury, Loss of Limb, or Death **DO NOT** use with Oxygen or gases other than Nitrogen.

2.0 SPECIFICATIONS/FEATURES**Dimensions:**

- Height: 46 11/16 in (118.6 cm)
- Length: 81 3/8 in (206.7 cm)
- Width: 38 1/2 in (97.8 cm)
- Weight: 370 lbs (169 kg)

Cart:

- Easy loading
- Use with all standard nine inch (9 in/22.9 cm) diameter Nitrogen bottles; CGA 580 connection
- Adjustable bottle stop
- Bottles fully captured
- Pneumatic tires
- Parking brake
- Hose compartment and storage hooks
- Instrument Panel
- 4 gallon plastic collection tank with hose connection
- Low pressure nitrogen hose for hydraulic system input
- Low pressure nitrogen hose for hydraulic system return

Low Pressure Regulator:

- 0-500 psi (0-34.5 bar) output
- 0-150 psi (0-10.3 bar) output to hydraulic system
- 15 foot (4.6 m) service hose

Temperature Range:

- 0° to 200°F (17.7° to 93.3° C)

3.0 SAFETY INSTRUCTIONS



CAUTION!

It is mandatory that this instruction manual be read and understood by all persons operating this nitrogen cart.

3.1 GENERAL

Information presented in this manual and on various labels, tags, and plates on the unit pertains to equipment design, installation, operation, maintenance and trouble shooting which should be read, understood, and followed for the safe and effective use of this equipment.

3.2 SAFETY

The operation, maintenance, and trouble shooting of this nitrogen cart requires practices and procedures which ensure personal operator safety and the safety of others. Therefore, this equipment is to be operated and maintained only by qualified persons in accordance with this manual and all applicable local codes.

NOTE: Safety instructions specifically pertaining to this unit appear throughout this manual highlighted by the signal words **WARNING, CAUTION, DANGER** which identify different levels of hazard.

WARNING: Denote practices which, if not carefully followed, could result in serious personal injury and/or death.

CAUTION: Denote practices which, if not carefully followed, could result in minor personal injury or damage to this equipment.

Nitrogen equipment must be kept clean and free from contaminants at all times. It is imperative that all inspection, maintenance, testing and servicing of Nitrogen system components be done by trained and qualified personnel using approved procedures.

4.0 PREPARATION FOR USE/ASSEMBLY INSTRUCTION



CAUTION!

Only use bottles for which this unit was designed: **Nine (9) inch (22.9 cm) diameter, 3000 psig (207 bars) maximum pressure with CGA 580 connection.**

1. Install bottles by removing bottle stop pin and sliding bottle stop toward rear.
2. Place bottles in cart, slide bottles forward against front stop. If using only one or two bottles load the lower bottle compartment, this will prevent the cart from becoming too top heavy.
3. Slide bottle stop securely against the back of the bottles and install bottle stop pin.



CAUTION!

Maximum towing speed is 10 mph (16 km/h).

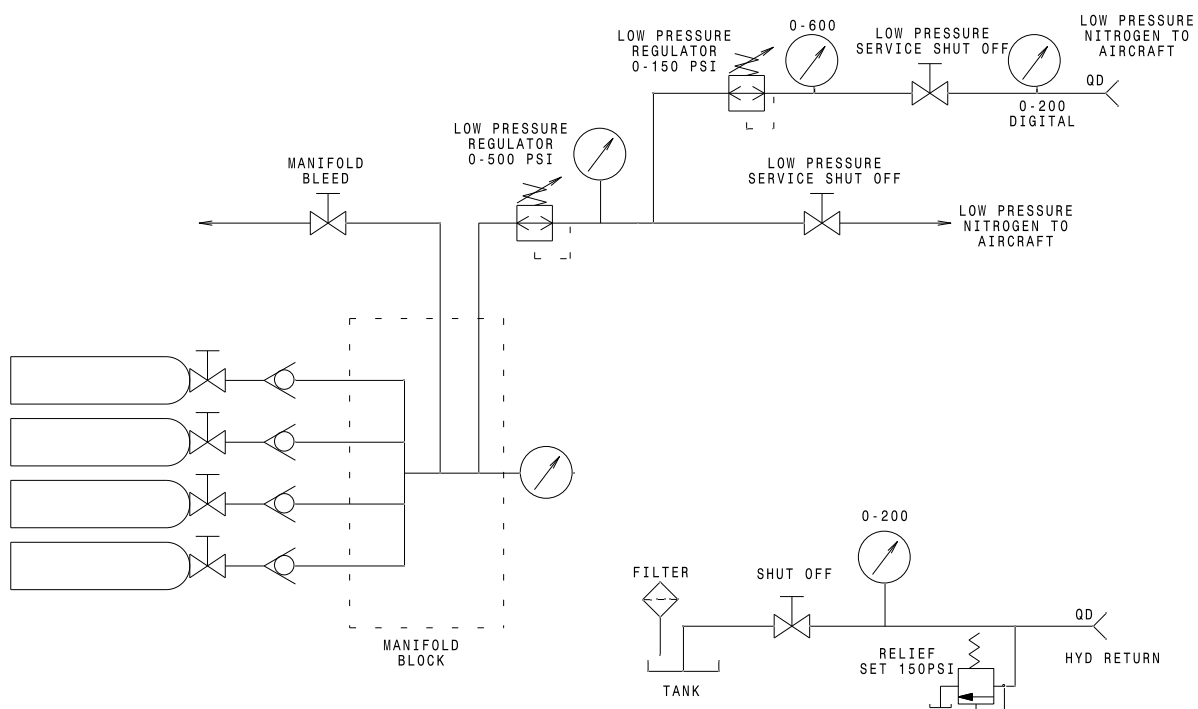

Figure 1 - Schematic

5.0 OPERATION OF NITROGEN CART



WARNING!

To Avoid Serious Injury, Loss of Limb, or Death:

1. **DO NOT** use with oxygen or gas other than Nitrogen.
2. **DO NOT** exceed 3000 psi (207 bar) inlet pressure.
3. **Servicing and maintenance of Nitrogen systems shall be done by only trained and qualified personnel using approved procedures.**

General: Information presented in this manual and on various labels on this unit pertains to equipment Specifications, Installation, Operation, Maintenance and Trouble Shooting which should be read, understood and followed for the safe and effective use of this equipment.

Training: Read this entire manual prior to operation of the unit. All personnel using this Nitrogen Cart should understand and follow this manual and receive training. We encourage our customers to call Tronair to discuss any operating or testing requirements. Telephone 419-866-6301 or 800-426-6301.

5.1 GENERAL SAFETY REQUIREMENTS

Pressures: Gasses under pressure are a potential hazard in the form of stored energy. Accidents can occur when this energy is improperly handled. Be sure that all equipment used is compatible and designed to control the pressures encountered.

Nitrogen: Nitrogen is chemically stable, nonflammable, and does not support combustion.

Handling: Nitrogen handling must be done with care. The rapid expansion of Nitrogen gas from a high pressure source to an area of low pressure, can produce cryogenic temperatures which cause severe burns.

5.2 BOTTLE CONNECTION INSTRUCTIONS

1. Rotate the Nitrogen supply bottles so that the manifold inlet hoses may be easily connected to the bottles. Make sure the hoses are not kinked or damaged.
2. Check that Nitrogen supply bottle shut off valve is closed. Recheck all fittings for tightness.
3. Clean out Nitrogen supply gas bottle valve outlet on one bottle and install Nitrogen inlet brass fitting and hose. Stop and inspect any indication of cross-threading or galling. Repeat for the remaining three (3) bottles.
4. If less than four (4) bottles are used, plug or cover unused inlet hoses to ensure Nitrogen system cleanliness.

5.3 TO READ INDIVIDUAL BOTTLE PRESSURE

1. Open a bottle shutoff valve.
2. Read pressure on bottle pressure gauge.
3. Close bottle shutoff valve.
4. Open manifold bleed valve to relieve pressure.
5. Close manifold to bleed valve.
6. Repeat procedure for other bottles.

5.0 OPERATION OF NITROGEN CART (continued)

5.4 EFFICIENT USE OF SYSTEM

Maximum pressure may be removed from supply bottles if aircraft are serviced from the lowest pressure bottle first. In this manner, the most Nitrogen may be removed from each bottle. Even bottles with relatively low pressures may be used to service aircraft if the aircraft has a depleted system.

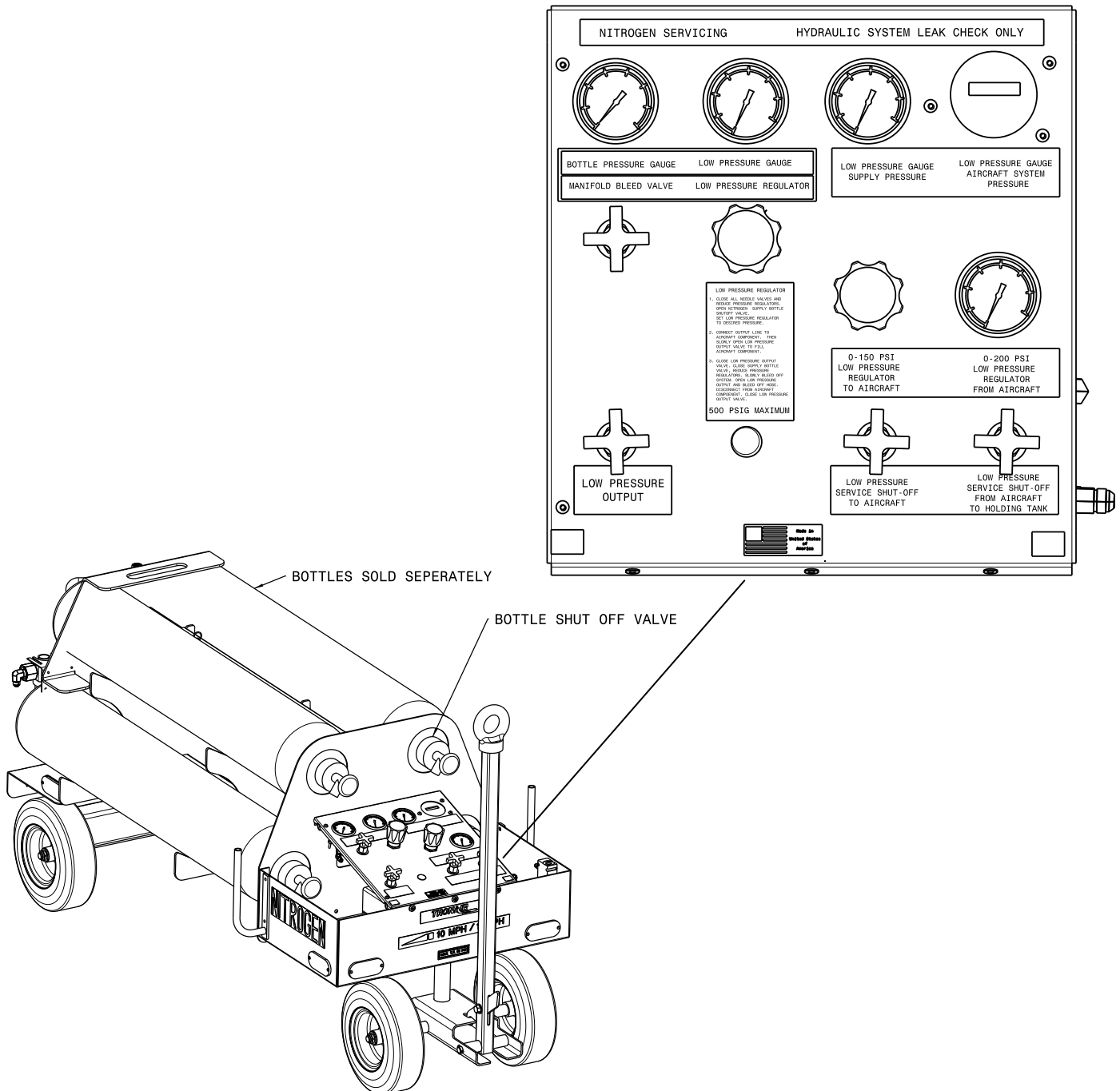

FIGURE 2 - Efficient Bottle Usage

5.0 Operation of nitrogen cart continued on following page

5.0 OPERATION OF NITROGEN CART (continued)

5.5 NITROGEN SYSTEM CONNECTION

WARNING!



If there are any differences between the following instructions and the aircraft maintenance manual, the aircraft maintenance manual will take precedence.

Reference Illustrated Parts Lists for replacement components.

1. Be sure all needle valves are in the closed (clockwise) position.
2. Decrease all pressure regulators to the minimum pressure setting. The regulator adjustment knobs are the rotating type. Clockwise rotation of the knob increases pressure and counter-clockwise rotation reduces pressure.
3. Connect Nitrogen fill line loosely to aircraft and purge line by slowly cracking open Nitrogen supply bottle shutoff valve.
4. Tighten Nitrogen fill line connection at aircraft.
5. Generally check unit and assure the tightness of all fittings, nuts and bolts.

WARNING!



Be sure fill line is secured prior to purging the unit. This will prevent the hose end from “whipping” if too much Nitrogen is allowed to flow through the unit.

5.6 AIRCRAFT NITROGEN SYSTEM (Low Pressure)

1. Ensure that all needle valves are in the closed (clockwise) position.
2. Ensure that all pressure regulators are decreased to minimum pressure settings (counterclockwise).
3. Connect the “BLUE” low pressure output hose to the low pressure application.
4. **Fully** open the Nitrogen supply bottle valve.
5. Slowly increase the low pressure regulator to obtain desired low pressure output. (Clockwise rotation increases pressure).
6. Open Low pressure output valve.

5.7 DISCONNECT LOW PRESSURE

1. **Slowly** close Nitrogen supply bottle shut-off valve.
2. Decrease low pressure regulator to minimum pressure setting after completing low pressure charge. (Counterclockwise rotation decreases pressure).
3. **Slowly** open, manifold bleed valve, and disconnect aircraft Nitrogen fill line from aircraft.
4. Cap aircraft Nitrogen fill line to prevent contamination.
5. Close all needle valves and decrease pressure regulators.

6.0 MAINTENANCE

- Maintain 45 to 50 psi (3.1 to 3.4 bar) tire pressure.
- Grease wheel bearings quarterly.
- All maintenance performed on this nitrogen cart shall be conducted in accordance with all applicable codes governing the handling, operation, installation and trouble shooting for high pressure Nitrogen operation. Maintenance is to only be done by qualified persons.
- The gauges on this unit should be inspected and calibrated annually to maintain and ensure accuracy.
- Manifold inlet hoses should be inspected weekly for signs of cracking or kinking, replace as necessary.
- Inspect Nitrogen output hoses prior to each use for signs of cracking or kinking, replace as necessary.
- Generally keep the entire unit clean and free from any contaminants. Visually inspect for any system leaks or damage. Correction of any problems prior to unit operation is imperative for safe operation.

6.1 STORAGE

Store the unit in a clean, dry area when not in use.

Ensure that all hoses are capped. The unit should be covered for the duration of unit storage to ensure Nitrogen system cleanliness for future aircraft system recharging.

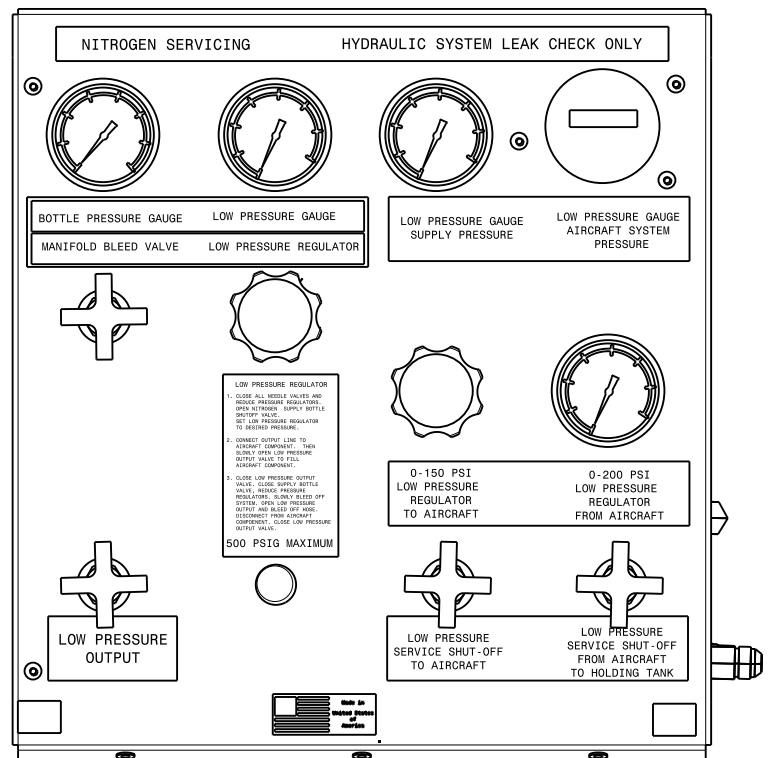

FIGURE 8 - Instrument Panel

7.0 GUARANTEES/LIMITATION OF LIABILITY

Tronair products are warranted to be free of manufacturing or material defects for a period of one year after shipment to the original customer. This is solely limited to the repair or replacement of defective components. This warranty does not cover the following items:

- a) Parts required for normal maintenance
- b) Parts covered by a component manufacturers warranty
- c) Replacement parts have a 90-day warranty from date of shipment

If you have a problem that may require service, contact Tronair immediately. Do not attempt to repair or disassemble a product without first contacting Tronair, any action may affect warranty coverage. When you contact Tronair be prepared to provide the following information:

- a) Product Model Number
- b) Product Serial Number
- c) Description of the problem

If warranty coverage is approved, either replacement parts will be sent or the product will have to be returned to Tronair for repairs. If the product is to be returned, a Return Material Authorization (RMA) number will be issued for reference purposes on any shipping documents. Failure to obtain a RMA in advance of returning an item will result in a service fee. A decision on the extent of warranty coverage on returned products is reserved pending inspection at Tronair. Any shipments to Tronair must be shipped freight prepaid. Freight costs on shipments to customers will be paid by Tronair on any warranty claims only. Any unauthorized modification of the Tronair products or use of the Tronair products in violation of cautions and warnings in any manual (including updates) or safety bulletins published or delivered by Tronair will immediately void any warranty, express or implied.

The obligations of Tronair expressly stated herein are in lieu of all other warranties or conditions expressed or implied. **Any unauthorized modification of the Tronair products or use of the Tronair products in violations of cautions and warnings in any manual (including updates) or safety bulletins published or delivered by Tronair will immediately void any warranty, express or implied and Tronair disclaims any and all liability for injury (WITHOUT LIMITATION and including DEATH), loss or damage arising from or relating to such misuse.**

Parts List

When ordering replacement parts/kits, please specify model, serial number and color of your unit.

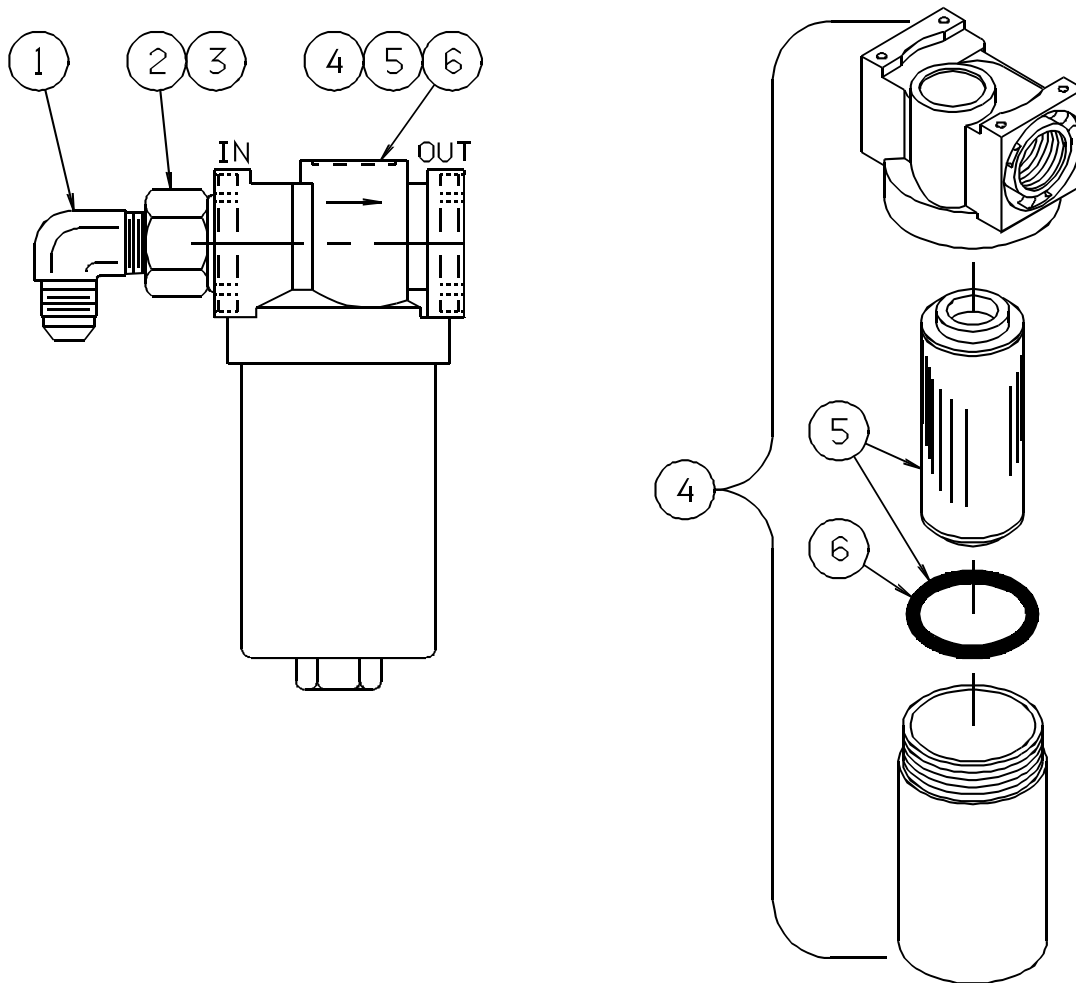

Item	Part Number	Description	Qty
1	N-2005-14-S	Elbow, Male	1
2	N-2202-09-S-E	Adaptor, Female Pipe	2
3	HC-2014-912	O-ring, Series 3	2
4	HC-1480	Assembly, Filter	1
5	HC-1483	Element, Filter	1
6	HC-2006-143	O-ring, Series 2	1

Parts List

When ordering replacement parts/kits, please specify model, serial number and color of your unit.

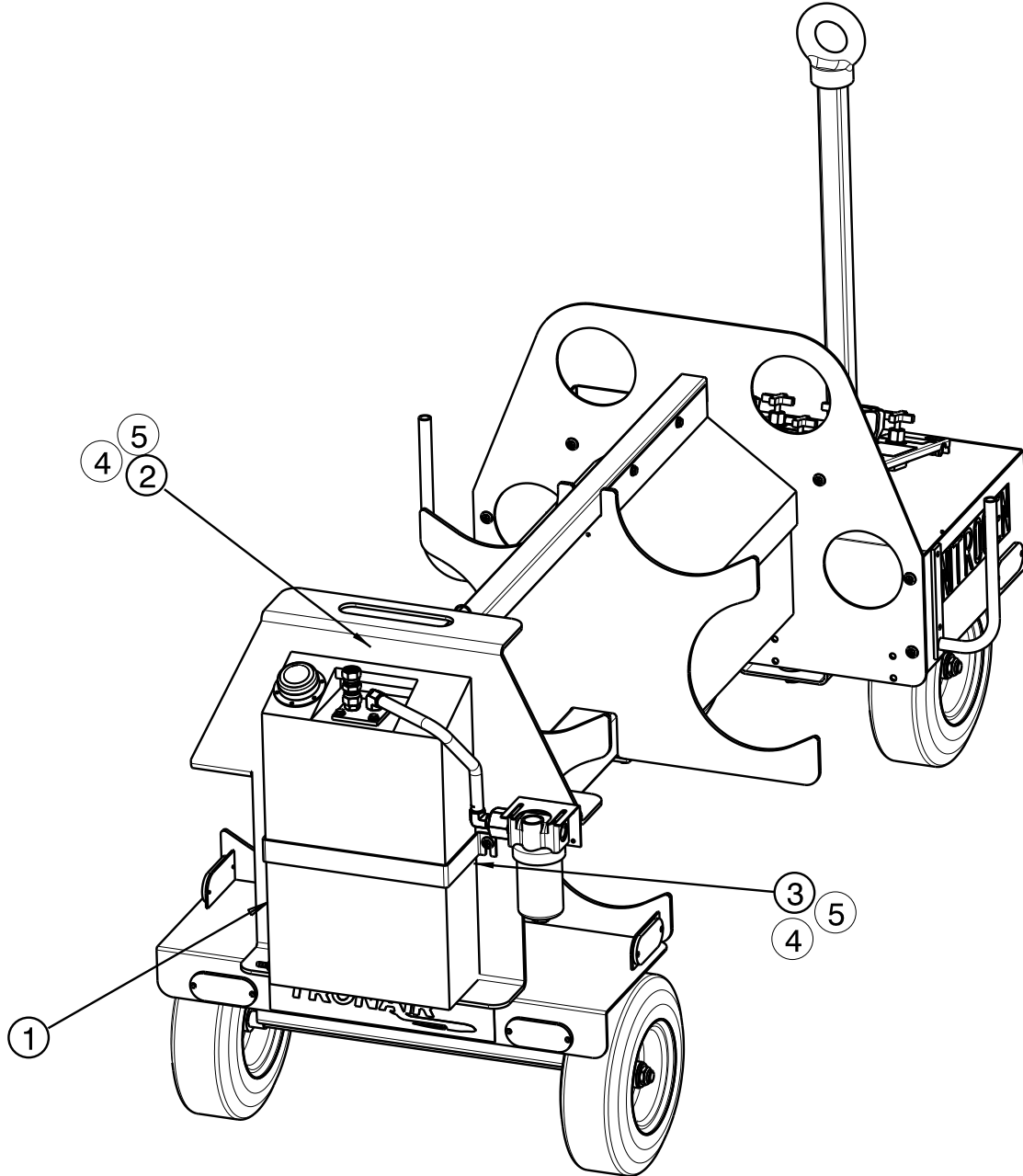

Item	Part Number	Description	Qty
1	Z-7588	Assembly, Waste Tank	1
2	S-2372	Clamp, Reservoir	1
3	S-2465	Strap, Waste Tank	1
4	G-1158-106110	Screw, ¼ - 20 Oval HD CRS RC	3
5	G-1489	Washer, Countersunk Finish	3

Parts List

When ordering replacement parts/kits, please specify model, serial number and color of your unit.

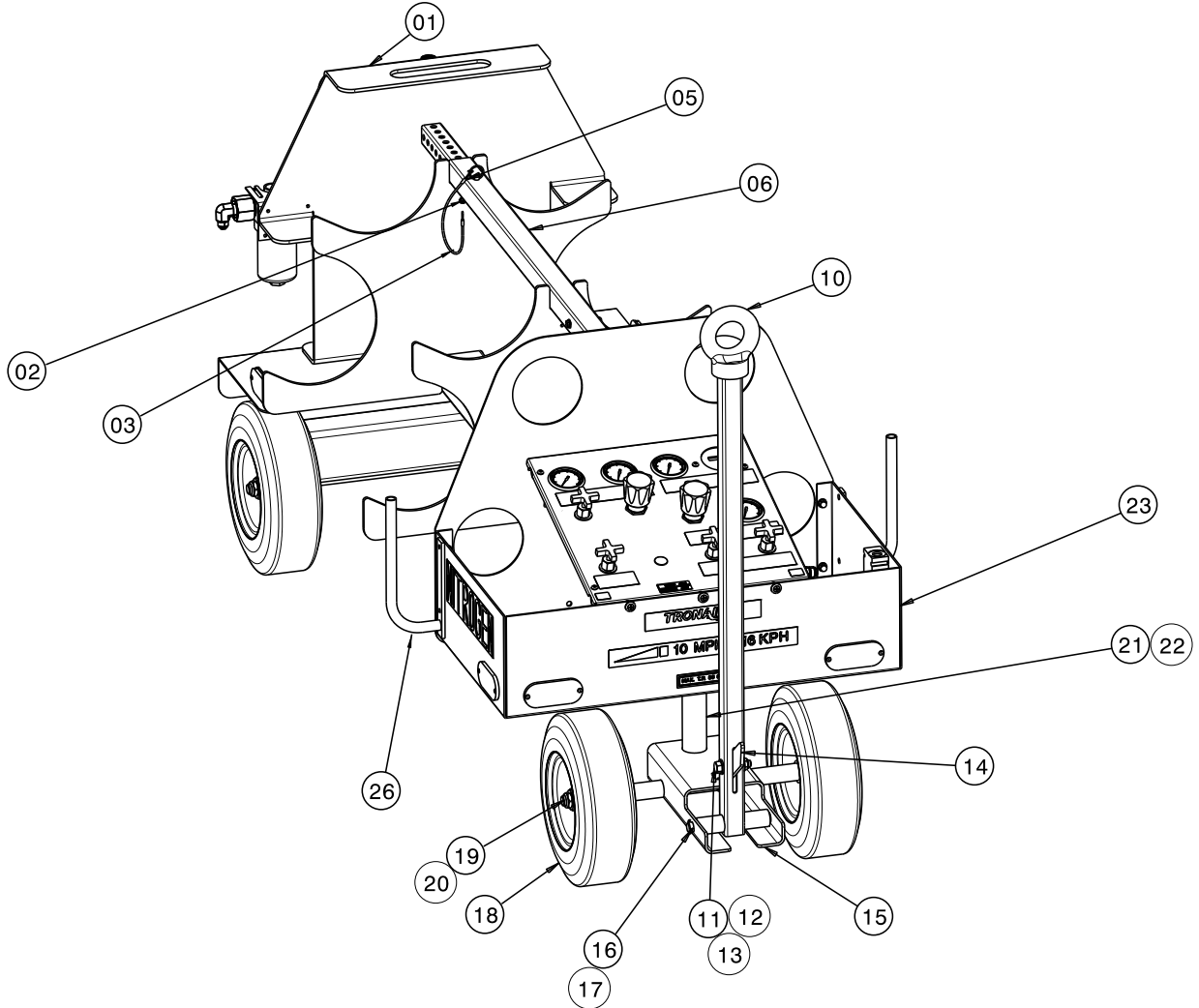

Item	Part Number	Description	Qty
1	Z-7586-01	Weldment, Back Stop	1
2	G-1150-103506	Screw, Hex Head Machine, #10-32 x 3/4" long	1
3	H-1026*12.0	Assembly, Lanyard	1
5	G-1307-0618	Pin, Aerofast	1
6	Z-7891-01	Weldment, Bottle Cart	1
10	Z-5584-01	Weldment, Towbar	1
11	G-1250-1090N	Flatwasher, 1/2 narrow	2
12	G-1203-1095	Elastic Jamnut, 1/2 - 20	1
13	G-1100-109522	Bolt, Hex Head Grade 5, 1/2 - 20 x 2-1/4" long	1
14	J-3427	Lever	1
15	Z-5580-01	Weldment, Front Truck	1
16	G-1301-02	Pin, Cotter	2
17	R-2096	Pin, Towbar	1
18	U-1041	Wheel, Pneumatic	4
	K-3107	Kit, Wheel Bearing	4

Parts List

When ordering replacement parts/kits, please specify model, serial number and color of your unit.

Item	Part Number	Description	Qty
19	G-1203-1115	Elastic, Jamnut ¾ - 16	4
20	G-1250-1110N	Flatwasher, ¾ narrow	4
21	H-2019-76	Bearing, Flange	2
22	G-1301-03	Pin, Cotter	1
23	S-2529-01	Shelf, 4-bottle cart	1
26	Z-7013-SP	Cable, Hanger	2

Parts List

When ordering replacement parts/kits, please specify model, serial number and color of your unit.

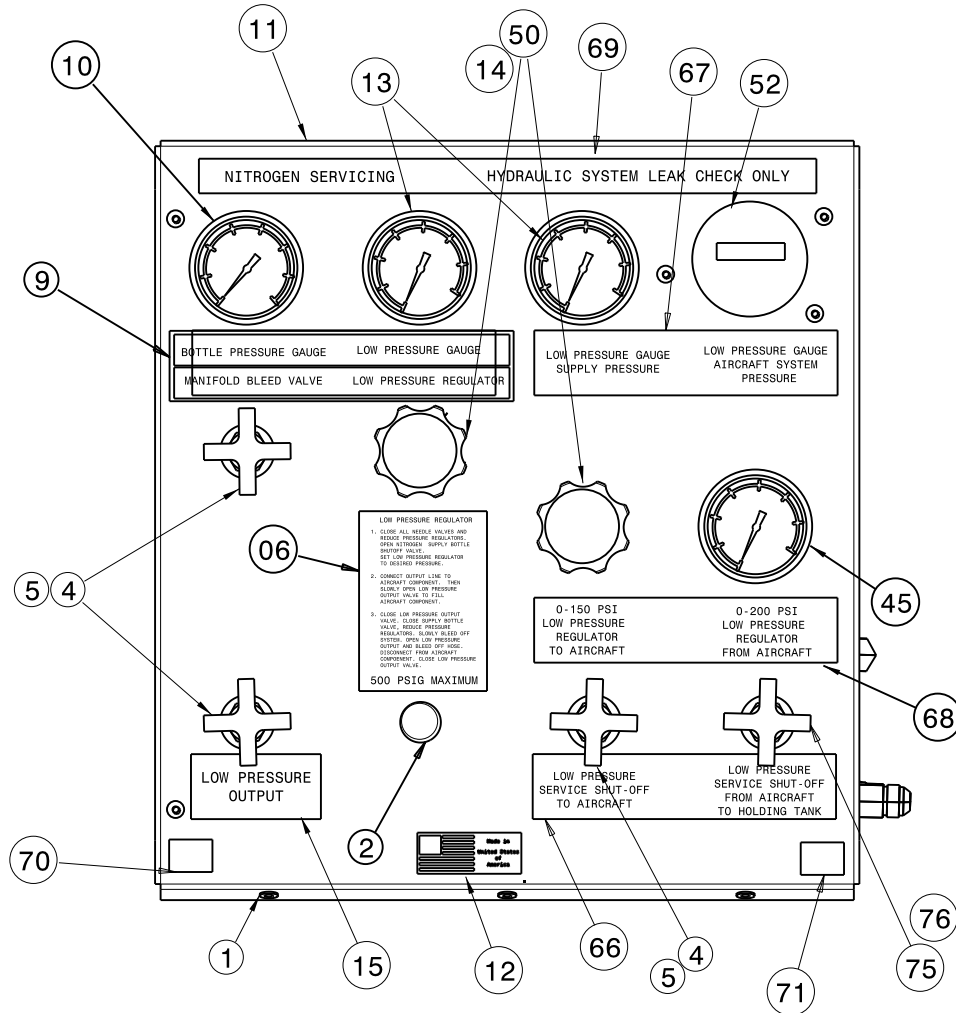

Item	Part Number	Description	Qty
1	G-1439-1050-S	Nutsert, ¼ - 20	7
2	H-2432-05	Plug, Sheetmetal	1
4	HC-1081-01	Valve, Needle ¼ NPT	3
5	HC-1122	Kit, Panel Mounting	3
6	V-2550	Label, Nitrogen Operation	1
9	V-2549	Label, Operator	1
10	HC-2279	Gauge, Pressure 0-5000 psi	1
11	S-2528-SP	Panel, Instrument	1
12	V-1001	Label, Made In USA	1
13	HC-2239	Gauge, Pressure 0-600 psi	2
14	H-2259	Locknut, Panel	2
15	V-2034	Label, Low Pressure	1
45	HC-1787	Gauge, Pressure 0-200 psi	1
50	PC-1089-01	Regulator, Low Pressure	2
52	H-3407	Gauge, Pressure 0-200 psi Digital	1
66	V-2359	Label, Low Pressure	1

Parts List

When ordering replacement parts/kits, please specify model, serial number and color of your unit.

Item	Part Number	Description	Qty
67	V-2368	Label, Pressure Gauge	1
68	V-2369	Label, Regulator/Gauge	1
69	V-2370	Label, Title	1
70	V-2371	Label, Low Output	1
71	V-2372	Label, Return	1
75	HC-1182-02	Valve, Needle	1
76	HC-1109	Kit, Valve Mounting	1

Parts List

When ordering replacement parts/kits, please specify model, serial number and color of your unit.

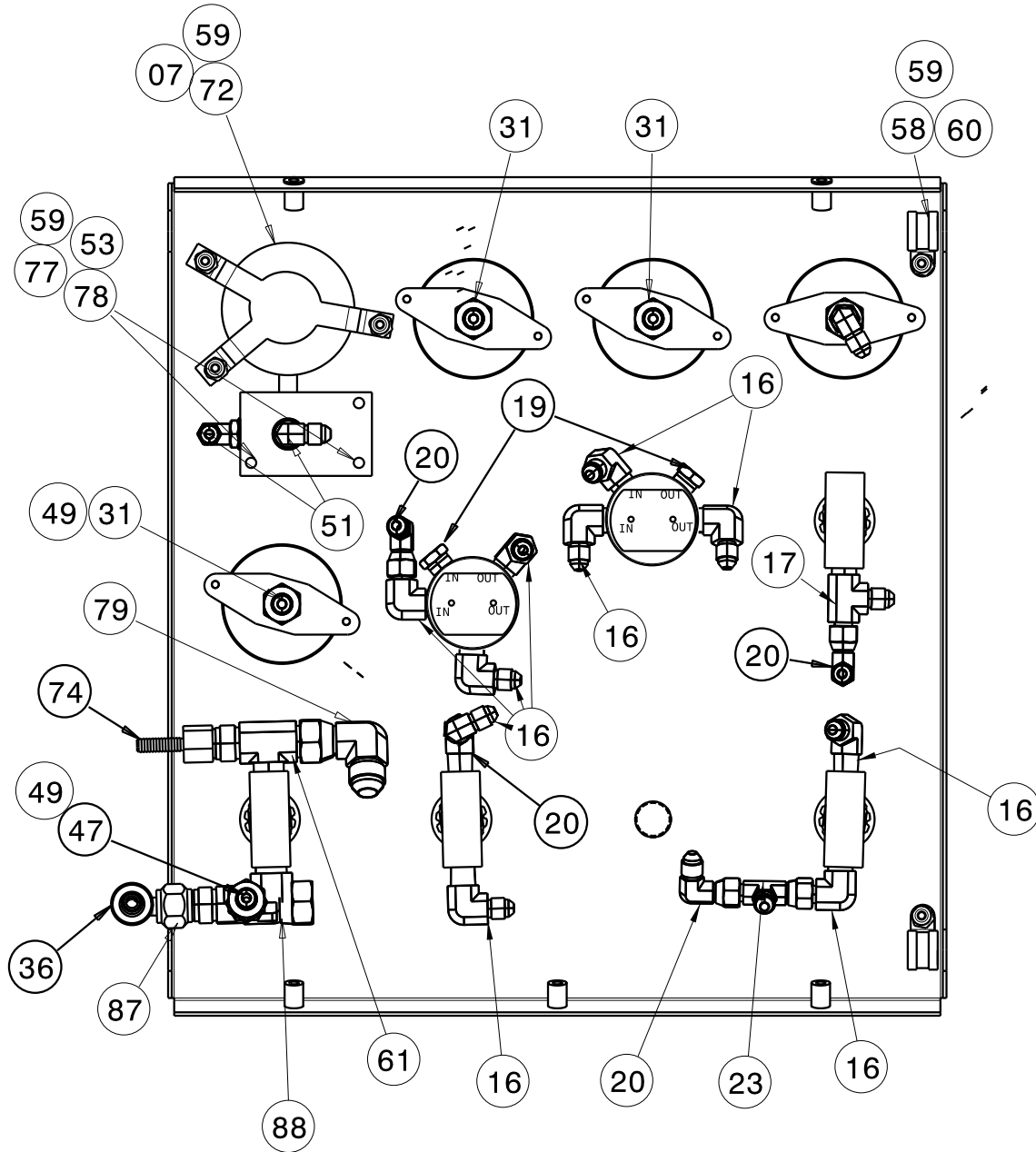

Item	Part Number	Description	Qty
7	G-1154-105204	Screw, BHCS ¼ - 20 x ½ LG	3
16	N-2005-04-S	Elbow, ¼ NPT x ¼ JIC	10
17	N-2017-04-S	Tee, Male Run, ¼ NPT x #4 JIC	1
19	N-2206-03-S	Plug, Hex Head	2
20	N-2002-03-S	Elbow, 90° Swivel, #4 JIC	4
21	N-2006-04-S	Elbow, Female	5
23	N-2016-03-S	Tee, Swivel Nut Run, #4 JIC	1
31	N-2010-04-S	Connector, Female	3
36	N-2500-03	Elbow, Swivel Hose JIC	1
47	N-2055-03	Reducer, Tube	1

Parts List

When ordering replacement parts/kits, please specify model, serial number and color of your unit.

Item	Part Number	Description	Qty
49	N-2026-01-B	Swivel, JIC Hose Fitting	2
51	N-2001-03-S-E	Elbow, Straight Thread	2
53	G-1100-105022	Screw, ¼ - 20 SOC BUT HD CAP	2
58	H-1721-02	Clamp, Electrical	2
59	G-1202-1050	ESN, ¼ - 20	8
60	G-1154-105206	Screw, ¼ - 20 SOC BUT HD CAP	2
61	N-2018-14-S	Tee, Branch	1
72	S-2466	Strap, Gauge	1
74	N-2026-05-B	Swivel, JIC 37°	1
77	J-4968	Manifold, Nitrogen	1
79	N-2002-06-S	Elbow, Swivel Nut	2
87	N-2016-06-S	Tee, Swivel Nut Run	1
88	N-2005-14-S	Elbow, Male	1

Parts List

When ordering replacement parts/kits, please specify model, serial number and color of your unit.

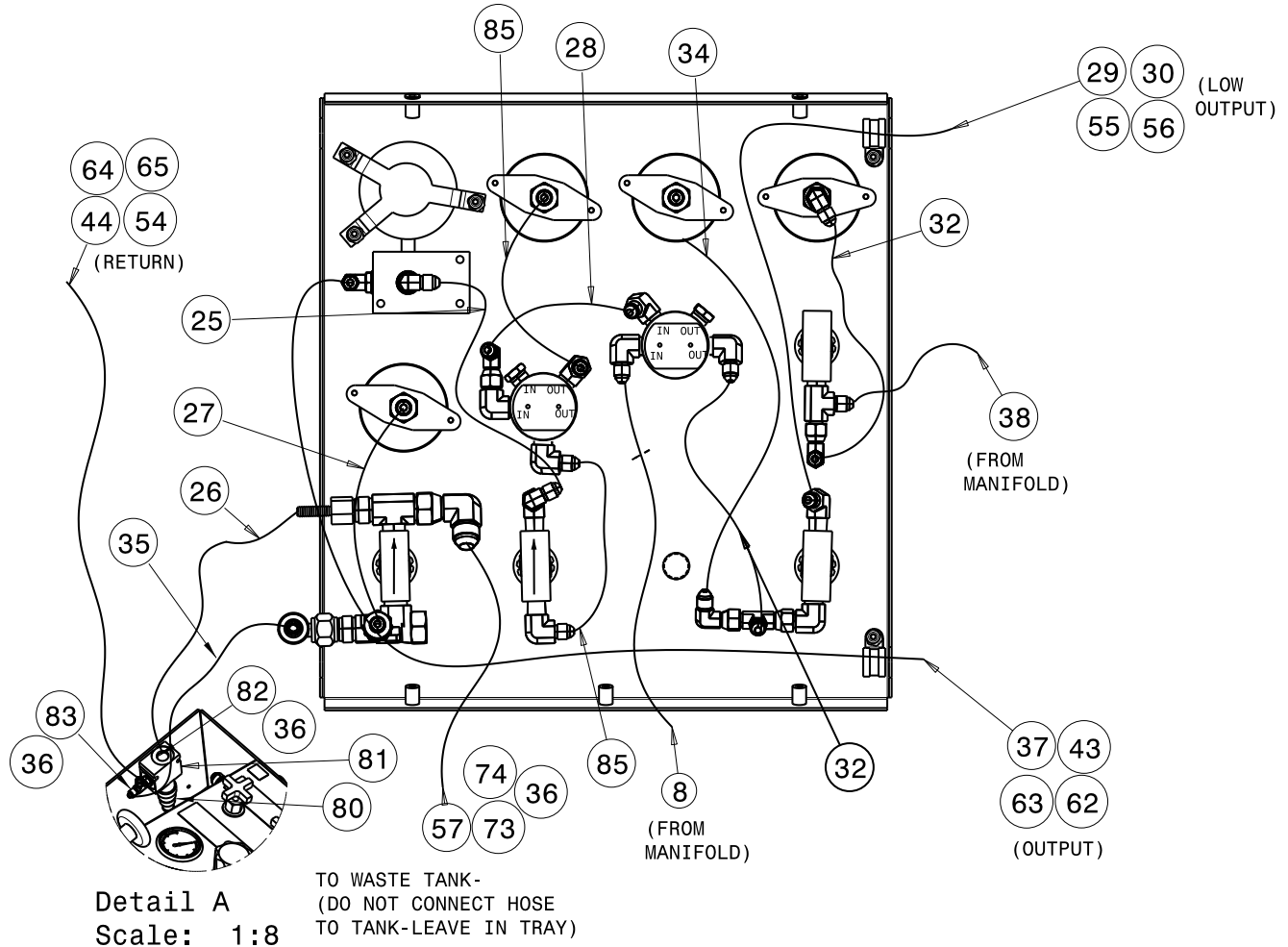

Detail A
 Scale: 1:8

TO WASTE TANK-
 (DO NOT CONNECT HOSE
 TO TANK-LEAVE IN TRAY)

Item	Part Number	Description	Qty
8	TF-1043-01*21.0	Assembly, Hose (#4 MB) x 21" LG	Ref
25	TF-1041-05*09.0	Assembly, Hose (#4 PE)	1
26	TF-1030-03-09.5	Assembly, Hose (#4 MB)	1
27	TF-1030-01*12.0	Assembly, Hose (#8 PE)	2
28	TF-1043-11*09.5	Assembly, Hose (#4 MB) x 9 1/2" LG	1
29	TF-1043-01*300	Assembly, Hose (#4 MB) x 300" LG	1
30	EC-1057-05*12.0	Tubing, Heat Shrink (Blue) x 12" LG	2
32	TF-1043-11*07.8	Assembly, Hose (#4 MB) x 7.8" LG	2
34	TF-1043-11*11.8	Assembly, Hose (#4 MB) x 11.8" LG	1
35	TF-1030-03*12.0	Hose	1
36	N-2500-03	Elbow, Swivel Hose JIC	3
37	TF-1043-01*180	Assembly, Hose (#4 MB) x 180" LG	1
38	TF-1043-11*20.0	Assembly, Hose (#4 MB) x 20" LG	1
43	N-2055-08-S	Reducer, Tube (12-4)	1
44	TF-1041-09*180	Assembly, Hose (#8 PR) x 180" LG	1
54	N-2055-18-S	Reducer, Tube (16-8)	1
55	PC-1067	Coupling, High Pressure Hose	1

Parts List

When ordering replacement parts/kits, please specify model, serial number and color of your unit.

Item	Part Number	Description	Qty
56	N-2009-03-S	Connector, Male	1
57	TF-1030-03-75.0	Assembly, Hose	1
62	N-2419-06	Coupling, Quick Disconnect	1
63	N-2418-06	Plug, Dust	1
64	N-2419-08	Coupling, Quick Disconnect	1
65	N-2418-07	Plug, Dust	1
73	N-2430-0808	Coupling, Quick Disconnect	1
74	N-2026-05-B	Swivel, JIC 37°	1
80	HC-1930-02	Valve, Pressure Relief Set, 150 psi (PE)	1
81	HC-1757	Block, Valve	1
82	N-2007-11-S-B	Connector, Run Straight Thread	1
83	N-2015-11-S-E	Tee, Run Straight Thread	1
85	TR375-04-010.00	TBG, SST .38 OD .035 W	2

Parts List

****When ordering replacement parts/kits, please specify model, serial number and color of your unit.****

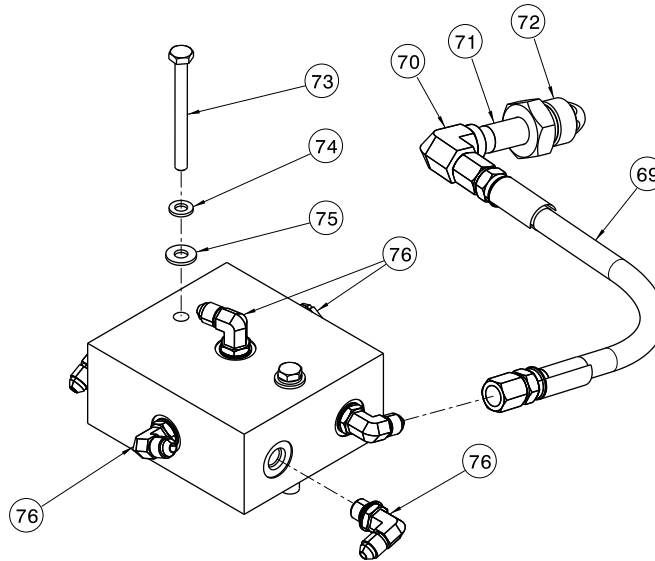

MANIFOLD AND BOTTLE HOSE ASSEMBLY

Item	Part Number	Description	Qty
69	TF-1043-07*21.0	Assembly Hose	4
70	N-2006-04-S	Elbow, 90°, ¼ NPT x #4 JIC	4
71	PC-1131	Nipple, Inlet w/check	4
72	PC-1001	Nut	4
73	G-1100-105026	Bolt, Hex Head Grade 5, ¼ - 20 x 2 ¾" long	2
74	G-1251-1050R	Lockwasher, ¼ regular	2
75	G-1250-1050N	Lockwasher, ¼ narrow	2
76	N-2001-03-S-B`	Elbow, 90°, #4 SAE x #4 JIC	6
	K-3262	Kit, Low Pressure Regulator Standard Repair, for:	
8	PC-1089-01	(Non-Metallic and Metallic Parts)	
	K-3263	Kit, Low Pressure Regulator Soft Goods Repair, for:	
8	PC-1089-01	(Non-Metallic Parts)	

VENDOR COMPONENT PARTS

Part Number	Description	Qty
PC-1133	Valve, High Pressure Relief	1



APPENDIX I

Smith's Installation & Operation Guide Pressure Regulators



INSTALLATION & OPERATION GUIDE FOR SMITH PRESSURE REGULATORS

Important safety and operational information contained in this booklet are emphasized by a system of classification using the words: **DANGER, WARNING, CAUTION, NOTICE.**

DANGER! Danger is used to indicate the presence of a hazard which will cause severe personal injury, death or substantial property damage, if the warning is ignored.

WARNING! Warning is used to indicate the presence of a hazard which can cause severe personal injury, death or substantial property damage, if the warning is ignored.

CAUTION! Caution is used to indicate the presence of a hazard which will or can cause minor personal injury, death or substantial property damage, if the warning is ignored.

NOTICE! Notice is used to notify people of installation, operation or maintenance information which is important but not hazard related.

SPECIALTY GASES ~ SAFETY AND TECHNICAL INFORMATION

Gaseous and liquefied compressed gases may be categorized in the following classifications: flammable, oxidant, corrosive, inert or toxic. Because these products may also be gases or liquids under pressure, the hazards accompanying high pressure and low temperature may also be present. The properties of a gas place it in one or a number of categories. Certain basic rules must be followed in order to handle specialty gases safely.

- A. Know the hazards associated with the gas.
- B. Know and understand the physical and chemical properties of the gas.
- C. Observe the necessary general precautions to be taken in the use of specialty gases and the precautions specific to the gas.

In addition to the safe handling and storage procedures presented in this section, the Compressed Gas Association and the Department of Transportation provide detailed gas safety information and regulations.

A. FLAMMABLE
Flammable gases when mixed with air, oxygen or other oxidants burn or explode upon ignition, depending upon the degree of confinement. Each flammable gas has a gas-in-oxidant concentration range within the limits of which the gas may be ignited. Flammable ranges are expressed in terms of air at ambient temperature and atmospheric pressure. A change in temperature, pressure or oxidant concentration may vary the flammable range considerably. Mixtures above and below the flammable range do not ignite. As a precaution in handling flammables, care must be taken to eliminate all possible sources of

ignition through the proper design of facilities, the installation of approved electrical systems, and the restriction of smoking and use of open flames. An explosimeter should be used to determine the existence of a flammable mixture in areas of suspected leakage.

B. OXIDANT

A number of gases, although nonflammable, may initiate and support combustion. Materials that burn in air burn more vigorously or even explosively in oxygen and certain other oxidants. All possible sources of ignition must be eliminated when handling oxidants. Oxidants must not be stored with combustible materials. Oil, grease, or other readily combustible substances must not come in contact with cylinders or equipment used in oxidant service.

C. CORROSIVE

Corrosives are those products that erode and deteriorate materials with which they come in contact; such as metals, fabrics, and human tissue. Some gases, although not corrosive in their anhydrous form, become corrosive in the presence of water. Special Care must be taken when selecting the proper construction materials for equipment in which corrosives are handled. Gases that do not cause deterioration but induce inflammation of human tissue are irritants. Inflammation of the tissue may occur after immediate, prolonged or repeated contact with the irritant. Protective clothing and equipment must be used to minimize exposure to corrosive or irritating materials.

D. INERT

Gases that at ordinary temperatures and pressure do not react with other materials are classified as inert. If released in a confined area, inert gases may displace the oxygen content of the air below the level necessary to sustain life. Asphyxiation, therefore, is the hazard associated with inert products. Adequate ventilation and monitoring of the oxygen content of confined areas minimizes the possibility of asphyxiation.

E. TOXIC

Toxic materials are those substances that may chemically produce injurious or lethal effects. The degree of toxicity and the effects vary with the compound. Some gases are especially noxious because they do not provide adequate warning of their presence (by color, odor, etc.) at low levels of concentration. Also, some products that are non-toxic in themselves may react with certain chemicals or decompose at elevated temperatures to produce toxic materials. Adequate ventilation, protective clothing, and suitable breathing equipment must be used to minimize exposure.

F. HIGH PRESSURE

Specialty gases are compressed to pressures up to 6000 psig. A sudden release of pressure may cause serious damage to personnel and equipment by propelling a cylinder or whipping a line. Factors that must be considered when choosing construction materials and designing gas-handling systems are the temperature, the pressure of the gas and the possibility of pressure buildup in the system.

NOTICE!

If you have a requirement or concern not covered in the booklet, contact your equipment supplier for assistance.

WARNING!

Read and observe all warnings and instructions before installing or operating any pressure regulating equipment. Improper application and operation of equipment with high pressure media (inerts, flammables, oxidizers or toxics) can result in damage to equipment or severe personal injury.

INTRODUCTION

Prior to installing or operating any pressure regulation equipment, read and follow the information in this booklet. Improper application and operation of regulators can result in damage to equipment or severe personal injury. All possible hazards and precautionary measures are not covered in this booklet. It is recommended that prior to using gas regulation equipment, you fully understand and comply with all established safety regulations.

SECTION I PRE-INSTALLATION PROCEDURES: COMPRESSED GAS CYLINDERS

WARNING!

Serious accidents can result from improper use and handling of high pressure compressed gas cylinders. Always follow instructions and safety precautions provided by your gas supplier.

WARNING!

Read and observe all warnings and instructions before installing or operating any pressure regulating equipment. Improper application and operation of equipment with high pressure media (inerts, flammables, oxidizers or toxics) can result in damage to equipment or severe personal injury.

Refer to CGA pamphlet page 1 for all regulations which apply to the safe handling and storage of combined gas cylinders.

1. Cylinders should always be kept in the vertical position and secured from falling.
2. Never use compressed gas cylinders without an approved gas pressure reducing regulator attached to the outlet of the cylinders.
3. Do not lubricate compressed gas fittings, gauges, regulators or regulator components.
4. Do not apply sealing tape to cylinder connections.
5. Do not use cylinders with damaged threads. Return the cylinder to your supplier indicating the problem.
6. Do not use cylinder connection adaptors. Use a regulator with the proper compressed gas fitting.

SECTION II PRE-INSTALLATION PROCEDURES: REGULATORS

WARNING

Regulators must be used only with the gases and pressures for which they are designed. Consult a material safety data sheet (MSDS) for media used to determine compatibility of gases and regulator components (available from your gas supplier). Failure to do this can result in an explosion, damage to equipment or severe personal injury.

1. Check the designed pressure rating of the regulator (stamped on the regulator body) and the scale range of the pressure gauges. They must be adequate for the cylinder pressure and the operating pressure.
2. Check that the materials used in the construction of the regulator are compatible with the intended media service.
3. Check that the regulator inlet connection is compatible with the cylinder outlet valve connections.
4. Fit the operating system with a check valve purge assembly and pressure relief devices as required.
5. Do not interchange pressure regulators or other equipment with different gases unless there is knowledge of the compatibility properties of the gases.
6. Do not use regulator equipment for oxygen service that has been in other gas service.

SECTION III INSTALLATION & OPERATION TEST FOR LEAKAGE

WARNING

Check cylinder valve connections and regulator inlet connections for foreign material before connecting. Use a clean dry lint-free cloth to remove contamination. When using oxygen or other oxidizers, it is extremely important that connections are clean and maintained. Failure to do this can result in an explosion, damage to equipment or severe personal injury.

1. Inspect the cylinder valve threads for damage and be sure the cylinder valve is free of oil, grease, dirt or any foreign material.
2. Attach the regulator to the cylinder valve and secure tightly using a wrench.
3. Connect the operation system to the regulator outlet.
4. Turn the regulator adjusting screw counterclockwise until the adjusting screw turns freely (no spring load) or until the adjusting screw is against the mechanical stop. (This allows the regulator valve to close).
5. Close the regulator outlet valve if one is used.

WARNING

Do not place yourself in front of or behind the regulator when opening the cylinder. Place yourself with the cylinder between you and the regulator.

6. Slowly open the cylinder valve until the full cylinder pressure is indicated on the high pressure regulator gauge. Then, open the cylinder valve all the way. This high pressure gauge should read the cylinder pressure. The delivery gauge should read zero.
7. With the valve at the outlet of the regulator closed and the

adjusting screw tension released, leave pressure on the inlet for 5 to 10 minutes. Delivery pressure gauge should not indicate any pressure increase. A pressure increase indicates leakage past the regulator valve seat.

WARNING

If leakage occurs, do not use the regulator.

8. Turn the adjusting screw clockwise to set a normal delivery pressure. If you are unable to attain a desired pressure or the pressure continues to rise above the setpoint, the regulator should not be used.
9. If the unit functioned properly in the previous step, close the cylinder valve and note the readings of both the inlet and delivery pressure gauges. After 5 to 10 minutes, a drop in the reading of either gauge indicates a leak in the system.

NOTICE!

Use an approved oil-free leak detection fluid to locate possible leaks at the inlet, threaded parts, through the regulator diaphragm or through the outlet valve.

10. If a leak is indicated at the inlet or at a threaded port, relieve all pressures from the regulator and retighten the connections. If a leak continues or is found at the diaphragm or outlet valve, do not use the regulator.
11. If the system is determined to be leak free, turn the adjusting screw clockwise until the desired pressure setting is indicated on the delivery pressure gauge.
12. Open the outlet valve to purge the system. Adjust the regulator adjusting screw to obtain the desired pressure setting at the flow conditions.

← CAUTION →

A regulator is not intended to be used as a shut-off device. When not in use, the cylinder valve should be closed. A pressure relief device should be installed downstream of the regulator or outlet valve to protect the process equipment in the case of a rise in operating pressures.

SECTION IV SYSTEM SHUTDOWN

1. Close the cylinder valve.
2. Release all media from the regulator and/or system so that both gauges read zero. If the gas is flammable, an oxidant, corrosive, or toxic, take appropriate measures to render it innocuous by employing suitable disposable system before venting the gas to the atmosphere.
3. Turn the adjusting screw counterclockwise until all spring load is released or the adjusting screw reaches the mechanical stop.
4. Close the outlet valve.
5. Disconnect the regulator.
6. If the regulator is to remain out of service, protect the inlet and outlet fittings from dirt, contamination or mechanical damage.
7. Replace the cylinder valve cap.

SECTION V PERFORMANCE CHARACTERISTICS

The following information is intended to assist you in identifying whether or not your regulator is performing properly.

A. Proper Performance

1. The delivery pressure will drop when flow is started and/or increased.
2. The delivery pressure will rise when flow is stopped. This difference in delivery pressure between flow and no flow condition is called lockup.
3. The delivery pressure of a single stage regulator will increase as the supply/cylinder pressure decays (as the cylinder is emptied). This will not happen with a 2-stage regulator until the supply pressure drops below the first stage set pressure of 250 psig (except 250 psig delivery range regulators, which are set at 400 psig).

B. Improper Performance

1. The delivery pressure continues to rise when flow is stopped (lock-up) without a change in adjusting screw position. This indicates valve seat wear or contamination with foreign materials allowing media to leak to the delivery side. This condition is referred to as "creep". Regulators that creep leakage must not be used until repaired.
2. A significant drop in delivery pressure during normal flow conditions, indicates internal blockage. Check inlet connection filters for contamination. If condition persists, regulator must be repaired.

SECTION VI CARE AND MAINTENANCE

WARNING

Periodic inspection and maintenance of your pressure regulator is essential for continued safe and satisfactory operation. The frequency of servicing will depend on duty cycle and type of media.

Equipment should have monthly inspection and annual maintenance (removing any deposits left by media and replacing any worn or damaged parts) under normal non-corrosive use and conditions. It is also recommended that when the system has high duty cycle or is used in corrosive service, more frequent inspection and maintenance may be necessary. Regulators requiring service repair should be sent to your equipment supplier.

A. Inspection

Use the following steps for regulator inspection:

1. Inspect gauges to assure they read zero when all pressure is released from the system.
2. With adjusting screw turned counterclockwise, to release all spring tension, slowly open cylinder valve. The high pressure gauge should read cylinder pressure and the delivery gauge should read zero.
3. With valve at outlet of regulator closed and adjusting screw tension released, leave pressure on inlet for 5 to 10 minutes. The delivery pressure gauge should not indicate any pressure

increase. A pressure increase indicates leakage past the regulator valve seat.

WARNING

If leakage is indicated, the regulator must be repaired and must not be used.

4. Then, turn adjusting screw clockwise to set a nominal delivery pressure. If unable to attain desired pressure setting or if delivery pressure continues to rise above setpoint, regulator should be repaired.
5. If unit functions properly in the previous step, close cylinder valve and note the readings of both the inlet and delivery pressure gauges. After 5 to 10 minutes a drop in reading of either gauge indicates a leak in the system.

NOTICE

Use an approved oil-free leak detection fluid to locate possible leaks at the inlet, any threaded port, through the regulator diaphragm or through the outlet valve.

6. If leak is at the inlet or at a threaded port, relieve all pressure from the regulator and then tighten. If leak continues or is found at the diaphragm and outlet valve, the regulator must be repaired and must not be used.

B. Storage

1. Regulators taken out of service for extended periods should receive proper care to extend their service life.
2. Regulators used in a non-corrosive media service should be wiped clean with a clean, dry, lint-free cloth and sealed in a plastic bag for storage in a dry area at room temperature.
3. Regulators used in a corrosive media service should be well flushed with dry nitrogen and sealed in a plastic bag. Regulators used for corrosive service may continue to corrode in storage after exposed to atmospheric oxygen and moisture.

C. Repair Service

Any regulator in need of service should be returned to your equipment supplier for evaluation.



APPENDIX II

Instrument Certification Notice



Instrument Certification Notice

The gauge Certificates of Calibration supplied for the gauge(s) on this unit contain the calibration data for the actual instrument calibrated, along with the calibration date of the **STANDARD** used to perform the calibration check.

The due date for re-calibration of the instrument should be based upon the date the instrument was placed in service in your facility. Re-calibration should be done on a periodic basis as dictated by the end user's quality system or other overriding requirements.

Note that Tronair, Inc. does not supply certificates of calibration on flow meters or pyrometers unless requested at the time of placed order. These instruments are considered reference indicators only and are not critical to the test(s) being performed on the aircraft.



APPENDIX III

Declaration of Conformity



DECLARATION of CONFORMITY

The design, development and manufacture is in accordance with European Community guidelines

18-4314-9800

Relevant provisions complied with by the machinery:
2006/42/EC

Relevant standards complied with by the machinery:
EN ISO 12100-1

Identification of person empowered to sign on behalf of the Manufacturer:

A handwritten signature in cursive script that reads "Patrick Finch". The signature is written in black ink and is positioned above a horizontal line.

Quality Assurance Representative