

**Model: 18-4317-0000
Tilttable One Cylinder
Transport Cart**

11/2018 – Rev. 02

REVISION

01
02

DATE

09/2013
11/2018

TEXT AFFECTED

Original release
Major revision

TABLE OF CONTENTS

PAGE

1.0	PRODUCT INFORMATION	1
1.1	DESCRIPTION.....	1
1.2	MODEL & SERIAL NUMBER.....	1
1.3	MANUFACTURER.....	1
1.4	SPECIFICATIONS	1
1.5	FEATURES.....	1
2.0	SAFETY INFORMATION.....	1
2.1	USAGE AND SAFETY INFORMATION.....	1
3.0	PREPARATION FOR USE	1
4.0	TRAINING	2
4.1	TRAINING REQUIREMENTS	2
4.2	TRAINING PROGRAM	2
4.3	OPERATOR TRAINING.....	2
5.0	MAINTENANCE.....	2
6.0	PROVISION OF SPARES.....	2
6.1	SOURCE OF SPARE PARTS.....	2
6.2	RECOMMENDED SPARE PARTS LISTS	2
7.0	GUARANTEES/LIMITATION OF LIABILITY	2
8.0	APPENDICES	2

This product can not be modified without the written approval of Tronair, Inc. Any modifications done without written approval voids all warranties and releases Tronair, Inc., its suppliers, distributors, employees, or financial institutions from any liability from consequences that may occur. Only Tronair OEM replacement parts shall be used.

1.0 PRODUCT INFORMATION

1.1 DESCRIPTION

Tiltable One Cylinder Transport Cart.

1.2 MODEL & SERIAL NUMBER

Reference nameplate on unit

1.3 MANUFACTURER

TRONAIR, Inc.
1 Air Cargo Pkwy East
Swanton, Ohio 43558 USA

Telephone: (419) 866-6301 or 800-426-6301
Fax: (419) 867-0634
E-mail: sales@tronair.com
Website: www.tronair.com

1.4 SPECIFICATIONS

Cart:

Height: 46 ¾ in (118.7 cm) Towbar in upright position
Length: 80 11/16 in (204.9 cm) Towbar in upright position
Width: 28 ½ in (72.4 cm)
Weight: 170 lbs (77 kg)
Finish: Powder Coat Tronair Blue

1.5 FEATURES

- Easy loading
- Use with all standard 9" diameter bottles

2.0 SAFETY INFORMATION

2.1 USAGE AND SAFETY INFORMATION

To insure safe operations please read the following statements and understand their meaning. Also refer to your equipment manufacturer's manual for other important safety information. This manual contains safety precautions which are explained below. Please read carefully.



WARNING!

Warning is used to indicate the presence of a hazard that can cause **severe personal injury, death, and/or substantial property damage** if the Warning Notice is ignored.



CAUTION!

Caution is used to indicate the presence of a hazard, which will or can cause **minor personal injury or property damage** if the Caution Notice is ignored.

3.0 PREPARATION FOR USE

This cart is shipped fully assembled and is ready for supply bottle installation.



CAUTION!

Only use 9 in (22.9 cm) diameter bottles for which this unit was designed.

The equipment should be kept clean, dry, and free from contaminants. It is imperative that all installation, inspection, maintenance, testing, and servicing of system components be done by trained and qualified personnel using approved procedures.

4.0 TRAINING

4.1 TRAINING REQUIREMENTS

The employer of the operator is responsible for providing a training program sufficient for the safe operation of the unit.

4.2 TRAINING PROGRAM

The employer provided operator training program should cover safety procedures concerning use of the unit in and around the intended aircraft at the intended aircraft servicing location.

4.3 OPERATOR TRAINING

The operator training should provide the required training for safe operation of the unit.

NOTE: Maintenance and Trouble Shooting are to be performed by a skilled and trained technician.

5.0 MAINTENANCE

- Maintain pressure listed on tires
- Grease wheel bearings quarterly

6.0 PROVISION OF SPARES

6.1 SOURCE OF SPARE PARTS

Spare parts may be obtained from the manufacturer:

TRONAIR, Inc.
1 Air Cargo Pkwy East
Swanton, Ohio 43558 USA

Telephone: (419) 866-6301 or 800-426-6301
Fax: (419) 867-0634
E-mail: sales@tronair.com
Website: www.tronair.com

6.2 RECOMMENDED SPARE PARTS LISTS

Reference the following page(s) for Replacement Parts and Kits available.

7.0 GUARANTEES/LIMITATION OF LIABILITY

Tronair products are warranted to be free of manufacturing or material defects for a period of one year after shipment to the original customer. This is solely limited to the repair or replacement of defective components. This warranty does not cover the following items:

- a) Parts required for normal maintenance
- b) Parts covered by a component manufacturers warranty
- c) Replacement parts have a 90-day warranty from date of shipment

If you have a problem that may require service, contact Tronair immediately. Do not attempt to repair or disassemble a product without first contacting Tronair, any action may affect warranty coverage. When you contact Tronair be prepared to provide the following information:

- a) Product Model Number
- b) Product Serial Number
- c) Description of the problem

If warranty coverage is approved, either replacement parts will be sent or the product will have to be returned to Tronair for repairs. If the product is to be returned, a Return Material Authorization (RMA) number will be issued for reference purposes on any shipping documents. Failure to obtain a RMA in advance of returning an item will result in a service fee. A decision on the extent of warranty coverage on returned products is reserved pending inspection at Tronair. Any shipments to Tronair must be shipped freight prepaid. Freight costs on shipments to customers will be paid by Tronair on any warranty claims only. Any unauthorized modification of the Tronair products or use of the Tronair products in violation of cautions and warnings in any manual (including updates) or safety bulletins published or delivered by Tronair will immediately void any warranty, express or implied.

The obligations of Tronair expressly stated herein are in lieu of all other warranties or conditions expressed or implied. **Any unauthorized modification of the Tronair products or use of the Tronair products in violations of cautions and warnings in any manual (including updates) or safety bulletins published or delivered by Tronair will immediately void any warranty, express or implied and Tronair disclaims any and all liability for injury (WITHOUT LIMITATION and including DEATH), loss or damage arising from or relating to such misuse.**

8.0 APPENDICES

APPENDIX I Declaration of Conformity

Parts List

When ordering replacement parts/kits, please specify model, serial number and color of your unit.

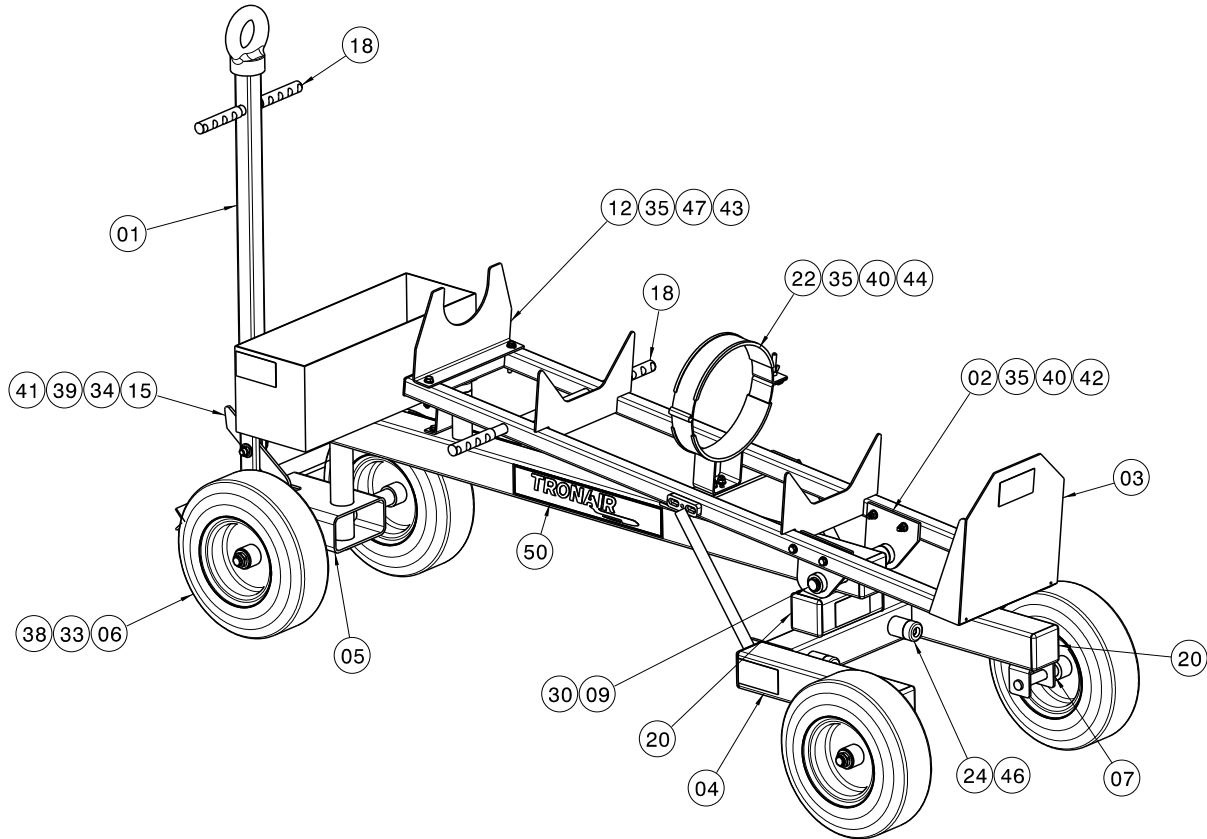

Item	Part Number	Description	Qty
1	Z-8020-01	Weldment, Towbar	1
2	Z-8003-01	Weldment, Bracket	2
3	Z-7999-01	Weldment, Lift	1
4	Z-7996-01	Weldment, Bottle Cart	1
5	Z-5580-SP	Weldment, Front Truck	1
6	U-1041	Assy, Tire/Wheel	4
7	TR-1813	Spacer	2
9	R-2698	Pin, Pivot	1
12	J-5292-01	Bracket, Bottle Stop	1
15	J-3427	Lever	1
18	H-3592	Grip, Handle	4
20	H-2649-18	Cap, End (Square)	8
22	H-2359	Clamp, Bottle	1
24	H-1547-12	Bumper, Rubber 1.5 x .75	3
30	G-1301-03	Pin, 1/8 x 1 1/2 Long Cotter	2
33	G-1250-1110N	Flatwasher, 3/4 Narrow	4
34	G-1250-1090N	Flatwasher, 1/2 Narrow	2
35	G-1250-1060N	Flatwasher, 5/16 Narrow	16
38	G-1203-1115	EJN, 3/4 - 16	4
39	G-1203-1095	EJN, 1/2 - 20	1
40	G-1202-1060	EJN, 5/16 - 18	8

Parts List

When ordering replacement parts/kits, please specify model, serial number and color of your unit.

Item	Part Number	Description	Qty
41	G-1100-109522	Bolt, Hex Head Grade 5, ½ - 20 x 2 ¼ LG	1
42	G-1100-106024	Bolt, Hex Head Grade 5, 5/16 – 18 x 2 ½ LG	4
43	G-1100-106522	Bolt, Hex Head Grade 5, 5/16 – 24 x 2 ¼ LG	2
44	G-1100-106010	Bolt, Hex Head Grade 5, 5/16 – 18 x 1 LG	2
46	G-1100-105006	Bolt, Hex Head Grade 5, 5/16 – 18 x ¾ LG	2
47	G-1203-1065	EJN, 5/16 – 24	2
50	V-1033	Label, Tronair	3
	K-2084	Kit, Replacement Wheel (single); consists of:	
6	U-1041	Assy, Tire/Wheel	1
33	G-1250-1110N	Flatwasher, ¾ Narrow	1
38	G-1203-1115	EJN, ¾ - 16	1
	K-3971	Kit, Replacement Lever; consists of:	
15	J-3427	Lever	1
34	G-1250-1090N	Flatwasher, ½ Narrow	2
39	G-1203-1095	EJN, ½ - 20	1
41	G-1100-109522	Bolt, Hex Head Grade 5, ½ - 20 x 2 ¼ LG	1

Parts List

When ordering replacement parts/kits, please specify model, serial number and color of your unit.

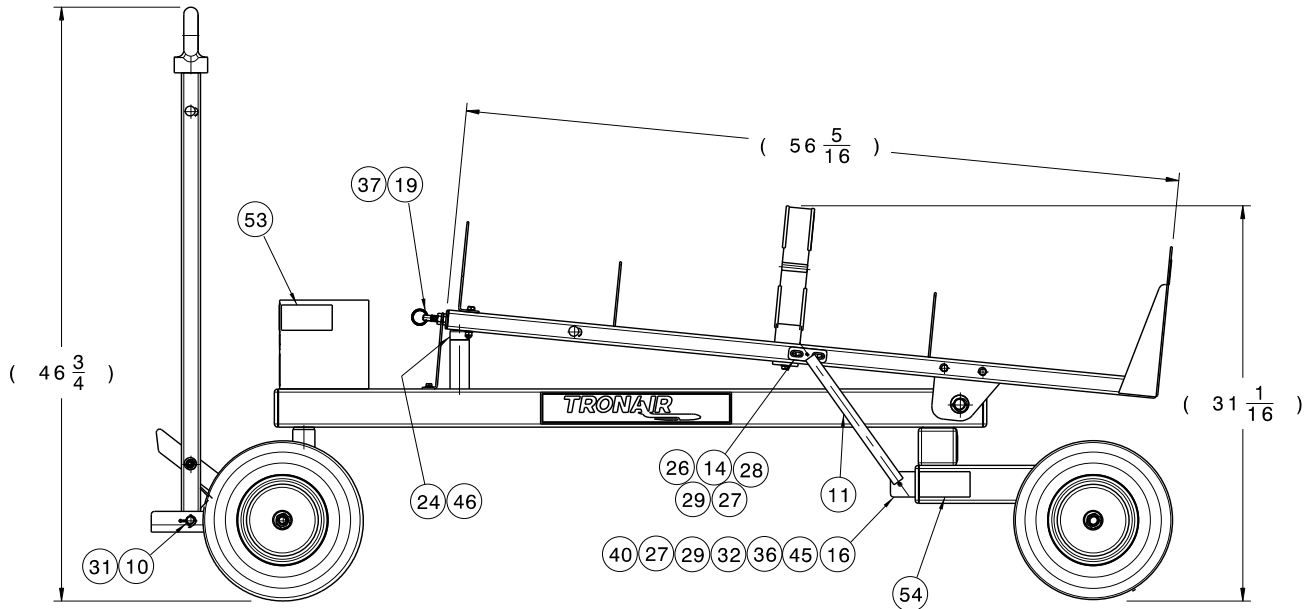

Item	Part Number	Description	Qty
10	R-2096	Pin, Towbar	1
14	J-5452-01	Pin, Anchor	2
16	Z-8122-01	Weldment, Bracket	2
19	H-3421	Plunger, Spring	1
24	H-1547-12	Bumper, Rubber 1.5 x .75	1
26	G-1152-105210	Screw, SOC FT HS 82° CAP	4
27	H-3666	Stud, Ball 5/16 x 18 x 15	4
28	H-3668	Cup, Retaining	4
29	G-1440-1050-S	Nutsert, ¼ - 20 Open Ended	8
31	G-1301-02	Pin, Cotter, ⅛ x 1 LG	4
32	G-1251-1050R	Lockwasher, ¼ Regular	4
36	G-1250-1050N	Flatwasher, ¼ Narrow	4
37	G-1207-1090	Nut, Jam, ½ - 13	2
40	G-1202-1060	EJN, 5/16 – 18	2
45	G-1100-105010	Bolt, Hex Head Grade 5, ¼ - 20 x 1 LG	8
46	G-1100-105006	Bolt, Hex Head Grade 5, 5/16 – 18 x ¾ LG	1
53	H-2806	Tape, Reflective Yellow	16.0
54	H-2807	Tape, Reflective Red	16.0
	K-3970	Kit, Replacement Pin; consists of:	
10	R-2096	Pin, Towbar	1
31	G-1301-02	Pin, Cotter, ⅛ x 1 LG	2

Parts List

When ordering replacement parts/kits, please specify model, serial number and color of your unit.

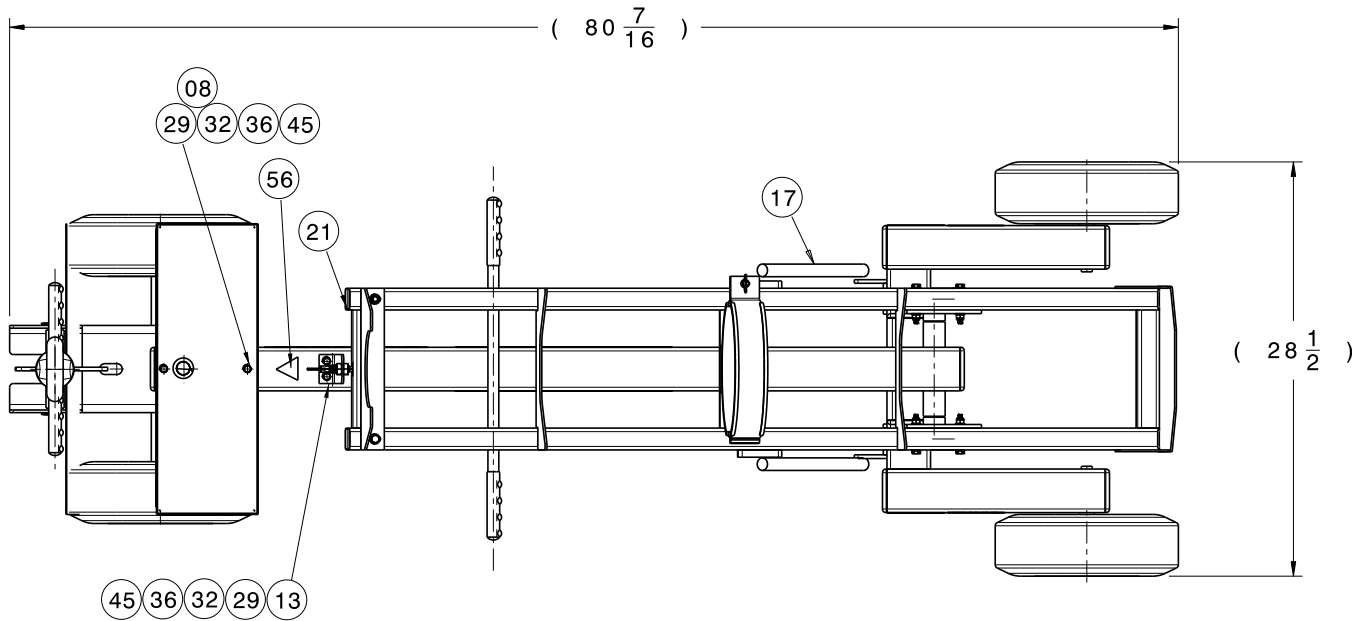

Item	Part Number	Description	Qty
8	S-2586-01	Sheetmetal, Box	1
11	PC-1156	Spring, Gas	1
13	J-5290-01	Bracket, Pin	1
17	PC-1159	Dampner	1
21	H-2649-09	Cap, End (Square)	2
29	G-1440-1050-S	Nutsert, Opend Ended, ¼ - 20	4
32	G-1251-1050R	Lockwasher, ¼ Regular	4
36	G-1250-1050N	Flatwasher, ¼ Narrow	4
45	G-1100-105010	Bolt, Hex Head Grade 5, ¼ - 20 x 1 LG	4
49	V-1850	Label, Max Tow	1
51	V-1779	Label, Serial Number CE	1
55	V-1001	Label, Made in the USA	1
56	V-1999	Label, ISO Crush	1

Parts List

When ordering replacement parts/kits, please specify model, serial number and color of your unit.

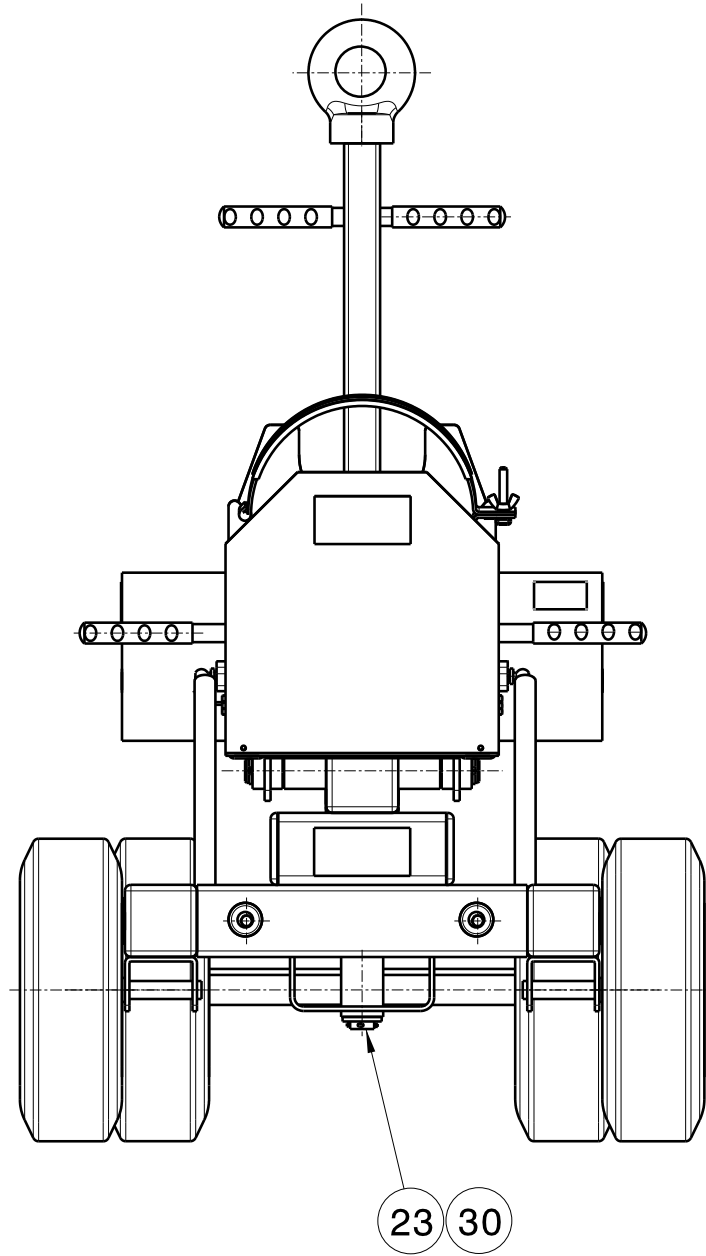

Item	Part Number	Description	Qty
23	H-2019-76	Bearing, Flange	2
30	G-1301-03	Pin, Cotter, 1/8 x 1 1/2 LG	1



APPENDIX II

Declaration of Conformity



DECLARATION of CONFORMITY

The design, development and manufacture is in accordance with European Community guidelines

18-4317-0000

Relevant provisions complied with by the machinery:
2006/42/EC

Relevant standards complied with by the machinery:
EN ISO 12100-1
CGA G-4.1 - 2004
SAE ARP 1176
SAE ARP 1532

Identification of person empowered to sign on behalf of the Manufacturer:

A handwritten signature in black ink that reads "Patrick Finch". The signature is written in a cursive style and is positioned above a solid horizontal line.

Quality Assurance Representative