

**Models: 19-4305-0000  
19-4305-0000  
Electric Potable Water Cart**



03/2023 – Rev. 08

**For Spare Parts, Operations & Service Manuals or Service Needs  
Scan the QR code or visit [Tronair.com/aftermarket](http://Tronair.com/aftermarket)**



REVISION	DATE	TEXT AFFECTED
03	01/2005	pg 6 Modified part number for item 13
04	03/2006	Modified all illustrations
05	05/2006	Modified illustrations
06	06/2009	Revised pump
07	08/2009	Modified 2.0 Specifications, 5.3 Charging Battery Instructions and Parts List
08	03/2023	Major revision

**TABLE OF CONTENTS**

	<b><u>PAGE</u></b>
<b>1.0 PRODUCT INFORMATION .....</b>	<b>1</b>
1.1 DESCRIPTION.....	1
1.2 MODEL & SERIAL NUMBER.....	1
1.3 MANUFACTURER .....	1
1.4 SPECIFICATIONS .....	1
<b>2.0 SAFETY INFORMATION .....</b>	<b>1</b>
2.1 USAGE AND SAFETY INFORMATION .....	1
2.2 GENERAL SAFETY REQUIREMENTS .....	1
<b>3.0 PREPARATION PRIOR TO FIRST USE .....</b>	<b>2</b>
3.1 ASSEMBLY.....	2
<b>4.0 TRAINING .....</b>	<b>2</b>
4.1 TRAINING REQUIREMENTS .....	2
4.2 TRAINING PROGRAM .....	2
4.3 OPERATOR TRAINING .....	2
<b>5.0 OPERATION .....</b>	<b>3</b>
5.1 TANK FILLING INSTRUCTIONS .....	3
5.2 AIRCRAFT FILLING INSTRUCTIONS .....	3
<b>6.0 STORAGE.....</b>	<b>3</b>
<b>7.0 MAINTENANCE .....</b>	<b>4</b>
7.1 BATTERY .....	5
7.2 FILTER.....	5
<b>8.0 PROVISION OF SPARES.....</b>	<b>5</b>
8.1 SOURCE OF SPARE PARTS.....	5
8.2 RECOMMENDED SPARE PARTS LISTS .....	5
<b>9.0 IN-SERVICE SUPPORT.....</b>	<b>5</b>
<b>10.0 GUARANTEES/LIMITATION OF LIABILITY .....</b>	<b>6</b>
<b>11.0 APPENDICES .....</b>	<b>6</b>



### 3.0 PREPARATION PRIOR TO FIRST USE

#### 3.1 ASSEMBLY

This Potable Water Cart has been thoroughly inspected and tested prior to packaging and shipment. After opening the shipping container and removing the cart, inspect it thoroughly for shipping damage.

Install towbar in position shown in **Figure 1**.

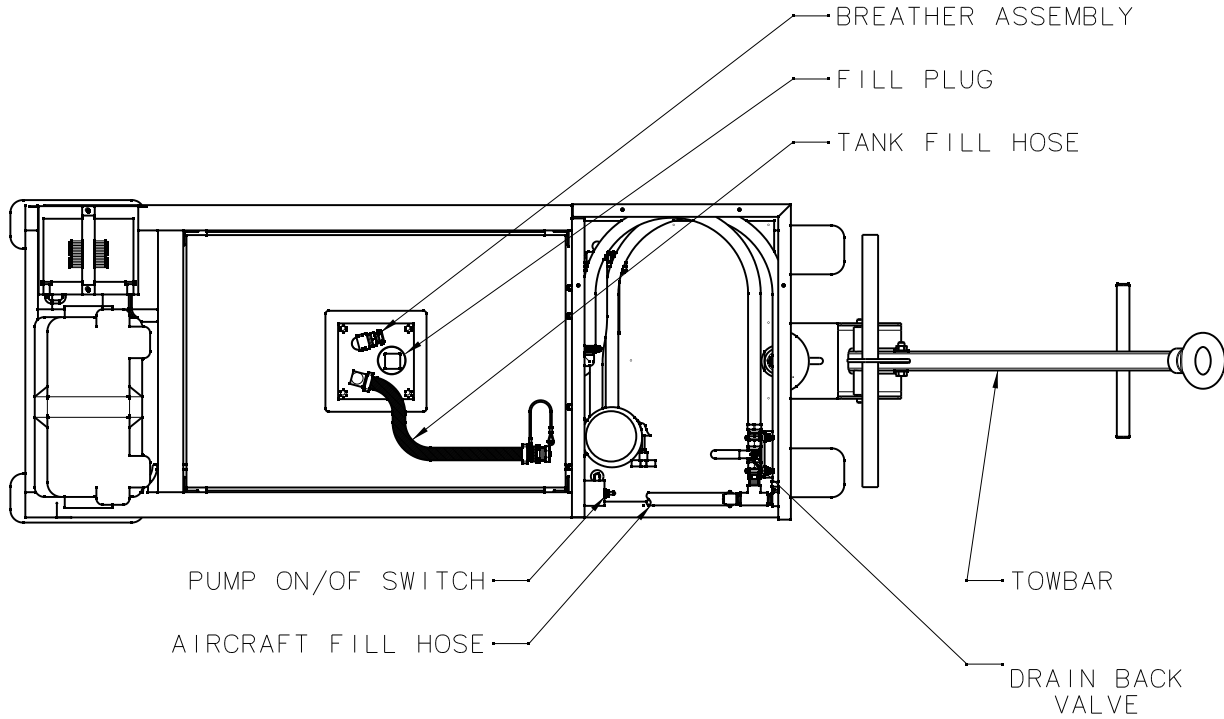

SHEET METAL REMOVED FOR CLARITY

**FIGURE 1 – General Layout**

### 4.0 TRAINING

#### 4.1 TRAINING REQUIREMENTS

The employer of the operator is responsible for providing a training program sufficient for the safe operation of the unit.

#### 4.2 TRAINING PROGRAM

The employer provided operator training program should cover safety procedures concerning use of the unit in and around the intended aircraft at the intended aircraft servicing location.

#### 4.3 OPERATOR TRAINING

The operator training should provide the required training for safe operation of the unit.

**NOTE: Maintenance and Trouble Shooting are to be performed by a skilled and trained technician.**

**5.0 OPERATION****WARNING!**

Before using this unit for the first time, thoroughly clean the unit in accordance with the World Health Organization applicable standard for a potable water transportation device.

For aircraft potable water use only. **DO NOT** put anything in this unit other than potable water.

**5.1 TANK FILLING INSTRUCTIONS**

1. Attach approved water source to fill hose (located on top of tank), or through tank access on top of unit, remove fill plug from tank, fill with water from bottles.
2. Monitor water level, fill to approximately one (1) inch from top of tank.
3. Remove water source and place plug back in tank fill hose, or reinstall fill plug.

**5.2 AIRCRAFT FILLING INSTRUCTIONS**

1. Check water level in aircraft.
2. Remove fill hose from hose compartment.
3. Connect hose to potable water connection on the aircraft.
4. Close drain back valve.
5. Switch on pump (located in the hose compartment) to fill the aircraft in accordance with the aircraft maintenance manual.
6. After filling aircraft, switch off pump & open drain back valve; disconnect hose from aircraft.

**6.0 STORAGE**

- The tank must be drained before storage.
- Disconnect all battery connections.
- Store the unit in a clean, dry place when not in use.
- Be sure that all hoses are capped and the unit is covered with a lint free covering.
- After storage, clean the tank as outlined in the maintenance section of this manual.

## 7.0 MAINTENANCE

Keep unit free of dirt and other contaminants. Store the unit in a cool, dry, and well ventilated area to help reduce the growth of bacteria in the unit.

Clean the unit in accordance with the World Health Organizations Standard or applicable code.

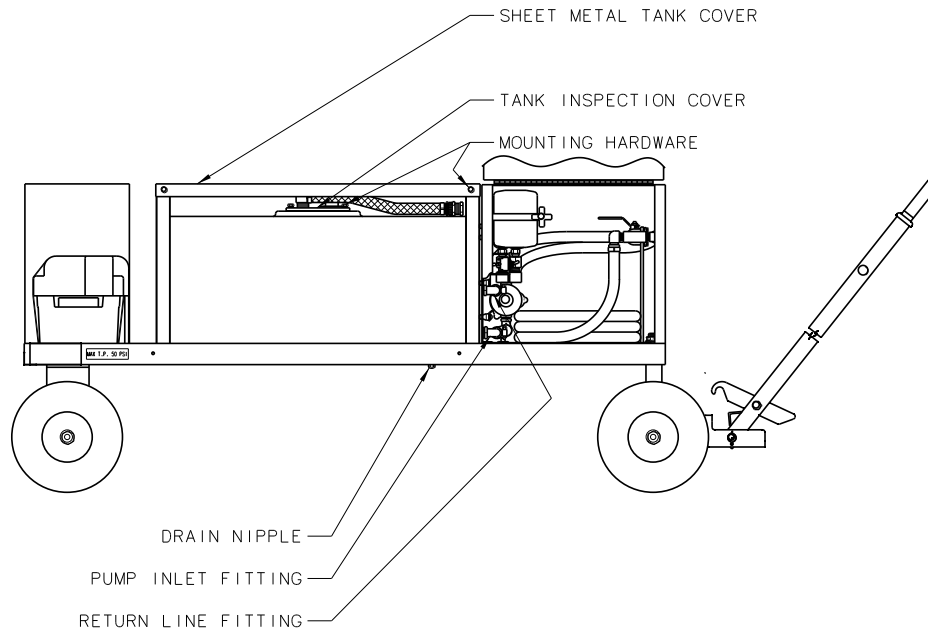

**FIGURE 2 – Maintenance Layout (Shown with access cover open)**

### TANK REMOVAL

(Reference Figure 2)

1. Drain tank by removing cap from drain nipple located on the bottom of the tank.
2. Remove sheet metal tank cover.
3. Disconnect return line and pump inlet hoses from the tank.
4. Remove return line and pump inlet fitting.
5. Remove tank from unit by lifting the tank straight up.

### INSPECTION COVER REMOVAL

1. Remove access cover mounting hardware.
2. Lift off access cover.

### INSPECTION COVER INSTALLATION

1. Clean inspection cover and tank mounting surfaces with a cleanser which is safe for potable water use.
2. Inspect inspection cover gasket for signs of wear, repair as necessary.
3. Install inspection cover on the tank, torque to 75 in-lbs.

### TANK INSTALLATION

1. Inspect tank for signs of wear; repair or replace as necessary.
2. Clean outside of tank with a cleanser which is compatible with potable water use.
3. Place tank in frame.
4. Use thread sealant on male threads of the return line and pump inlet fittings (Permatex Industrial - no more leaks #80724, or equivalent.)
5. Install fittings into tank.
6. Connect return line hose to return line fitting. Connect pump inlet hose pump inlet fitting, tighten clamps.
7. Install sheet metal tank cover.

## 7.1 BATTERY

### WARNING!



Battery posts, terminals and related accessories contain lead and lead compounds; chemicals known to the State of California to cause cancer and reproductive harm.

Wash hand after handling.



**EXPLOSIVE GAS!** Batteries produce explosive hydrogen gas while being charged. To prevent a fire or explosion, charge batteries only in well ventilated areas. Keep sparks, open flames, and other sources of ignition away from the battery at all times. Keep batteries out of the reach of children. Remove all jewelry when servicing batteries.

Before disconnecting the negative (-) ground cable, make sure all switches are OFF. If ON, a spark will occur at the ground cable terminal, which could cause an explosion if hydrogen gas or gasoline vapors are present.



**ELECTRICAL SHOCK!** Never touch electrical wires or components. They can be sources of electrical shock.

1. Remove battery box cover.
2. Inspect battery connections for tightness and cleanliness.
3. Inspect condition of battery by sight glass located on top, should be green in color. If not, ensure battery is charged. If still not green, replace battery.
4. Re-install battery box cover and secure with strap.

## 7.2 FILTER

**NOTE: filters need to be replaced after 1,000 gallons of service.**

1. Unscrew wing nut, remove vee-clamp and cover; unthread the expended cartridge.
2. Insert new cartridge; hand tighten only.
3. Replace cover and vee-clamp and hand tighten wing nut.
4. Run approximately one (1) gallon (4 liters) of water through unit to expel trapped air.

## 8.0 PROVISION OF SPARES

### 8.1 SOURCE OF SPARE PARTS

Spare parts may be obtained from the manufacturer:

<b>TRONAIR</b> , Inc.	Telephone: (419) 866-6301 or 800-426-6301
1 Air Cargo Pkwy East	Fax: (419) 867-0634
Swanton, Ohio 43558 USA	E-mail: sales@tronair.com
	Website: www.tronair.com

For Spare Parts, Operations & Service Manuals or Service Needs:  
Scan the QR code or visit [Tronair.com/aftermarket](http://Tronair.com/aftermarket)



### 8.2 RECOMMENDED SPARE PARTS LISTS

Reference the following page(s) for Replacement Parts and Kits available.

Recommended Spares to be kept on hand:  
WC-1051 ..... Filter, Water Purifier  
WC-1052 ..... Filter Replacement – Filter Only  
EC-1656 ..... 12 Volt Battery

## 9.0 IN-SERVICE SUPPORT

Contact Tronair, Inc. for technical services and information. See Section 1.3 – Manufacturer.



**10.0 GUARANTEES/LIMITATION OF LIABILITY**

Tronair products are warranted to be free of manufacturing or material defects for a period of one year after shipment to the original customer. This is solely limited to the repair or replacement of defective components. This warranty does not cover the following items:

- a) Parts required for normal maintenance
- b) Parts covered by a component manufacturers warranty
- c) Replacement parts have a 90-day warranty from date of shipment

If you have a problem that may require service, contact Tronair immediately. Do not attempt to repair or disassemble a product without first contacting Tronair, any action may affect warranty coverage. When you contact Tronair be prepared to provide the following information:

- a) Product Model Number
- b) Product Serial Number
- c) Description of the problem

If warranty coverage is approved, either replacement parts will be sent or the product will have to be returned to Tronair for repairs. If the product is to be returned, a Return Material Authorization (RMA) number will be issued for reference purposes on any shipping documents. Failure to obtain a RMA in advance of returning an item will result in a service fee. A decision on the extent of warranty coverage on returned products is reserved pending inspection at Tronair. Any shipments to Tronair must be shipped freight prepaid. Freight costs on shipments to customers will be paid by Tronair on any warranty claims only. Any unauthorized modification of the Tronair products or use of the Tronair products in violation of cautions and warnings in any manual (including updates) or safety bulletins published or delivered by Tronair will immediately void any warranty, express or implied.

The obligations of Tronair expressly stated herein are in lieu of all other warranties or conditions expressed or implied. **Any unauthorized modification of the Tronair products or use of the Tronair products in violations of cautions and warnings in any manual (including updates) or safety bulletins published or delivered by Tronair will immediately void any warranty, express or implied and Tronair disclaims any and all liability for injury (WITHOUT LIMITATION and including DEATH), loss or damage arising from or relating to such misuse.**

**11.0 APPENDICES**

- APPENDIX I Versa-Pure Microfiltration Systems for Aircraft Replacement Parts Lists
- APPENDIX II Safety Data Sheet Lead Acid Battery

## Parts List

When ordering replacement parts/kits, please specify model, serial number and color of your unit.

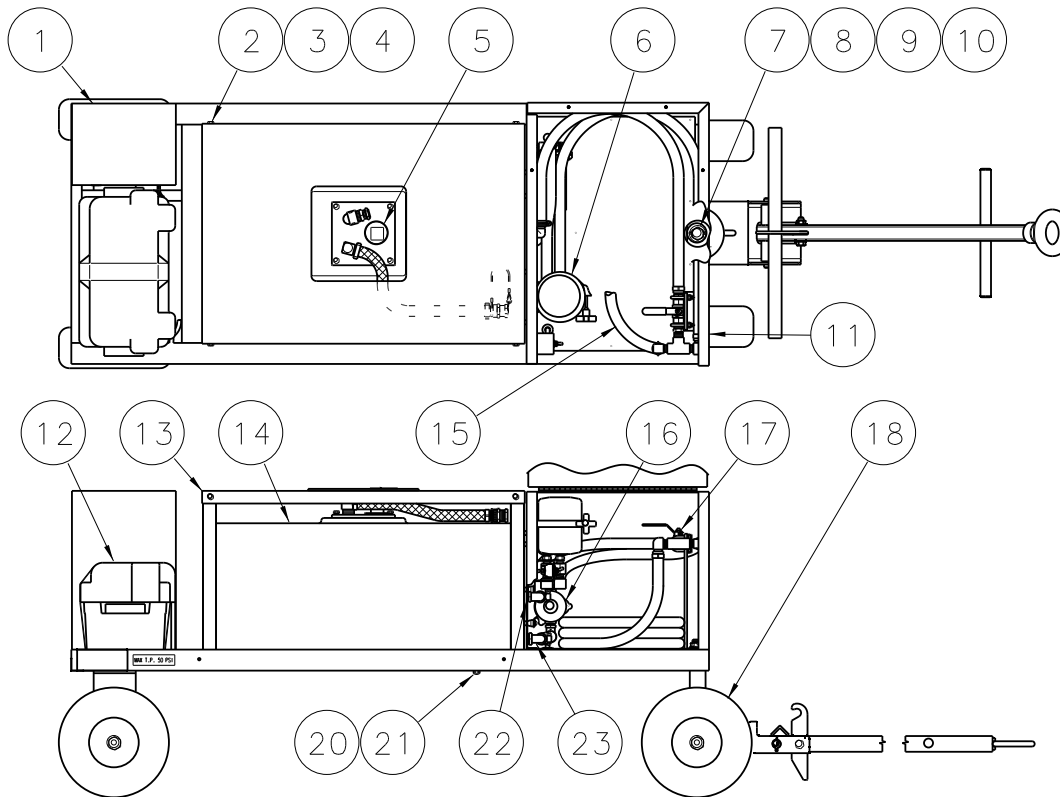

Item	Part Number	Description	Qty
1	EC-2215	CHARGER, BATTERY – 19-4305-0000 ONLY	1
	EC-1595	CHARGER, BATTERY – 19-4305-0000-A1 ONLY	
2	G-1100-105006	BOLT, 1/4-20 X 3/4	4
3	G-1250-1050N	FLATWASHER, 1/4 NARROW	8
4	G-1202-1050	STOPNUT, 1/4-20, ELASTIC	4
5	N-1507	PLUG, 2 INCH	1
6	WC-1051	FILTER, WATER PURIFIER	1
N/S	WC-1052	FILTER REPLACEMENT – FILTER ONLY	REF
N/S	710540	FILTER HOUSING GASKET	REF
7	G-1230-01	NUT, 1-14 UNS THREAD SPINDLE	1
8	G-1283	WASHER, SPINDLE	2
9	G-1301-03	PIN, COTTER	1
10	H-1841-13	BEARING, NYLON	2
11	K-2087	KIT, REPLACEMENT REFLECTOR (AMBER)	1
12	EC-1656	BATTERY, 12 VOLT	1
13	S-1389	COVER, TANK	1
14	H-1829	TANK	1
15	TF-1081-06*180	HOSE, AIRCRAFT FILL	1
16	Z-7120	PUMP	1
17	HC-1137	VALVE, 1/2" BALL	1
18	K-1550	KIT, REPLACEMENT WHEEL (SINGLE)	4
20	N-1503-01	CAP, THREADED PVC	1
21	N-1526	NIPPLE, 3" PVC	1
22	N-1509-01	FITTING, MALE BARB	1
23	N-1040-13	FITTING, MALE ELBOW	1

**Electrical Schematic**

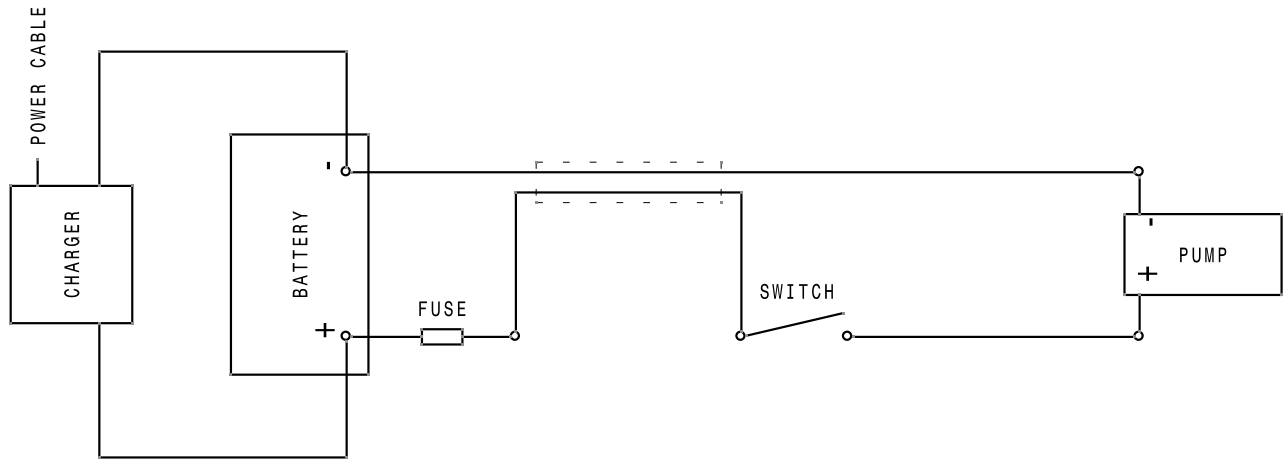

**Hydraulic Pump Performance**

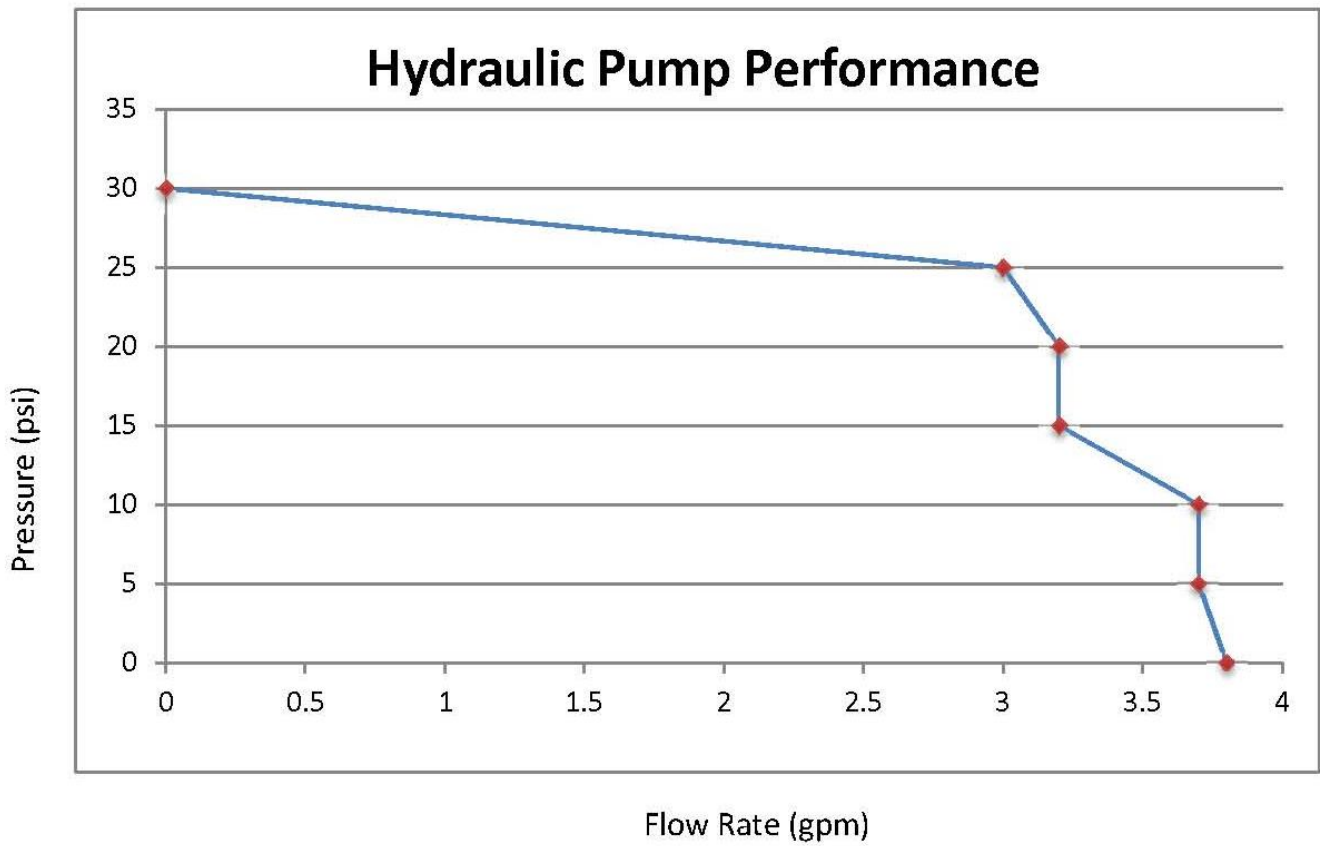





## **APPENDIX I**

### **Versa-Pure Microfiltration Systems for Aircraft Replacement Parts List**





General Ecology's

Supersedes 200809 and 200810

# VERSA-PURE®

## AC-2 Drinking Water Microfiltration Systems For AIRCRAFT

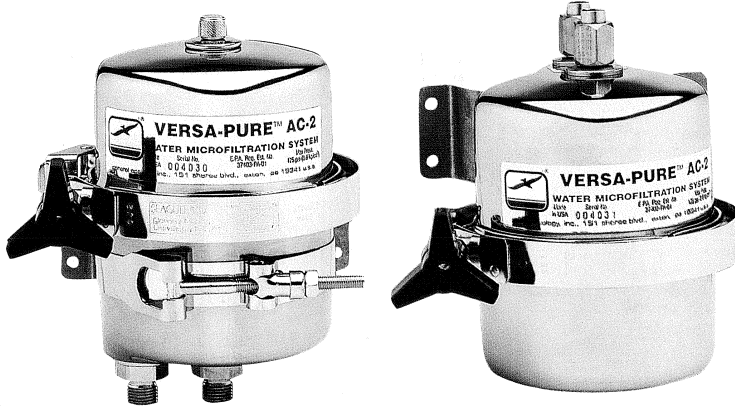

AC-2 shown with MS 33514 E6 flareless tube connections and vent port and with SAE 37° JIC flare ports and nuts.

Specified into McDonnell Douglas, Deutsche Aerospace Airbus, Boeing, Gulfstream and other leading aircraft, General Ecology's compact, advanced design VERSA-PURE® microfiltration systems lead the industry. Configurations are available to meet virtually any installation requirement. We offer both **SAE 37° JIC Flare** and **MIL SPEC 33514 E6 flareless tube connections**. Inlet, outlet and vent/drain ports can be mounted in virtually any orientation and we offer two different types of mounting...or no brackets at all if you want to use your own custom mount. Additionally, our latest configuration offers a mounting bracket especially drilled for retrofit upgrades.

Many earlier aircraft galleys and lavatories included GAC (granular activated carbon) taste and odor filters that do not offer the effectiveness and versatility of General Ecology's VERSA-PURE systems, especially when furnished with our **RS-1SG bacteria removal cartridge**. With little or no modification to the aircraft piping and no drilling required for mounting, VERSA-PURE units can be retrofitted in minutes. Bracket hole patterns exactly match those of older systems and the same type of inlet and outlet ports can be specified. Please consult with our aircraft systems engineers for assistance.

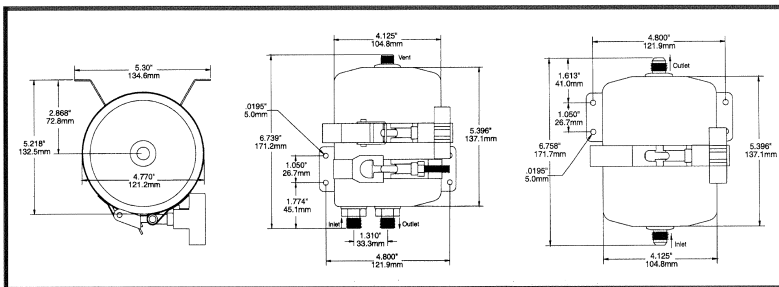

To place an order or to receive more information call: **800-441-8166** EST. USA  
Fax: 610-363-0412 or Email: [gecology@ix.netcom.com](mailto:gecology@ix.netcom.com)

### MATERIALS

- Manifold Cover, Bowl, Vee-clamp and Mounting Bracket—Lifetime, heavy-gauge non-corrosive 300 series stainless steel with sanitary finish.
- Wing Nut—High temperature thermoset with brass insert.
- Gaskets and Seals—FDA accepted elastomers.

### TO SERVICE UNIT (NO TOOLS REQUIRED)

- Unscrew wing nut, remove Vee-clamp and unthread the expended cartridge.
- Insert new cartridge—hand tighten only.
- Replace cover and Vee-clamp and hand-tighten wing nut.
- Run about one gallon (4 liters) of water through unit to expel trapped air.
- Maximum pressure 125 psi (8.75 kg/cm<sup>2</sup> - 8.6 Bars).

### TWO CARTRIDGES TO CHOOSE FROM: AL-21SG CARTRIDGE

- No asbestos; safely removes or reduces chlorine and other foul tastes and odors including thousands of chlorinated and organic pollutants, amoebic cysts, algae and some colloids.
- Vibration resistant, heat resistant per U.S. CFR 121.2536.
- U.S. Public Health Service/F.D.A. accepted.
- Rated capacity: 3800 gal. (14,000 liters)

### RS-1SG CARTRIDGE

- The same features as the AL-21SG plus 0.4 micron retention to remove enteric waterborne disease bacteria, Giardia, amoebic cysts, liver flukes, and Cryptosporidia; and to provide even more effective chemical, taste and odor reduction. Approximately 4000 liters nominal capacity at 25 psi inlet pressure.

For pressure, flow, and other characteristics of the AL-21SG and the RS-1SG see General Ecology specification sheets P/N 200600 and 200601.

## AC-2 Parts

(Both flareless and 37° flare fittings are shown.)

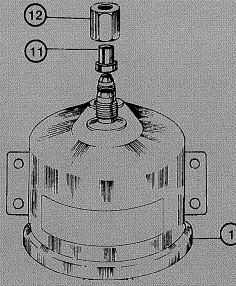
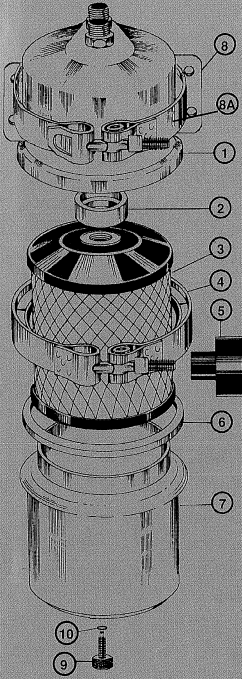

### PARTS LIST

#### VERSA-PURE™ AC-2 Microfiltration Systems

Index No.	Part No.	Nomenclature	Qty.
1	**	Cover	1
2	710541	Cart. Gasket	1
3	770006	AL-215G Cartridge	1
	778000	RS-15G Cartridge	1
4	710536	Vee Clamp	1
5	710032	Wing Nut	1
6	710540	Housing Gasket	1
7	**	Bowl	1
8	710061	Wall Bracket	1
8A	710535	Quick Release Bracket Clamp	1
9	770045	Vent / Drain Knob	1
10	342006	Vent / Drain O-ring	1
11	710071	37° Flare Sleeve	2
12	710072	37° Flare Nut	2

\*\*Part No. for Cover and Bowl is determined from configuration of unit as shown in drawings below.

AC-2 pressure vessels can be provided with either MS flareless fittings or with SAE 37° flare fittings (*Connecting fittings are not included with the MS Flareless units*). Mounting is accomplished with an adjustable bracket secured by a band clamp or with a rigid welded bracket. The long life 2 to 5 micron AL-21-5G cartridge is standard but the 0.4 micron **bacteria removing** RS-15G cartridge can also be ordered and used without modification or adapters.

## How To Order

Call: 800-441-8166 EST. USA

Fax: 610-363-0412

Email: [gecology@ix.netcom.com](mailto:gecology@ix.netcom.com)

To specify configuration order as follows:

## AC-2

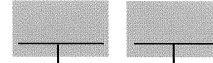

### Configuration

(Select a configuration from the drawings below. For example the 2G comes with a band clamp bracket on top and has two ports on top and a drain on the bottom.)

### Cartridge Type

(Select a cartridge type)  
**AL** - 2 to 5 micron, dechlorinating, taste and odor removal.  
**RS** - 0.4 micron **bacteria removal**, dechlorinating, taste and odor removal

## Shipping Information

Unit Weight (less cartridge) ..... 1.9 lbs. (.9 kg)

Cartridge Weight ..... 1.1 lbs. (.5 kg)

10 Microfiltration Units with Cartridges

Master Case ..... 34 lbs. (15 kg), 2.546 cu. ft.

25 Cartridges

Master Case ..... 30 lbs. (13.6 kg), 1.34 cu. ft.

## STANDARD CONFIGURATIONS for the AC-2 with MS Flareless fittings and adjustable bracket

Alternate configurations quoted upon request.

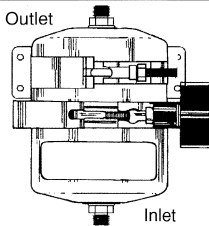

**2E** Outlet on top  
Inlet on bottom

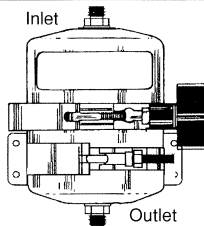

**2F** Inlet on top  
Outlet on bottom

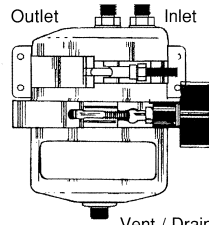

**2G** Inlet and Outlet on top  
Drain on bottom

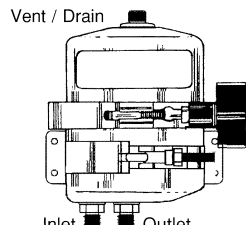

**2H** Outlet and Inlet on bottom  
Vent on top

## STANDARD CONFIGURATIONS for the AC-2 with 37° Flare fittings and rigid welded bracket

Alternate configurations quoted upon request.

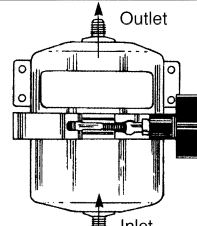

**1A** Outlet on top  
Inlet on bottom

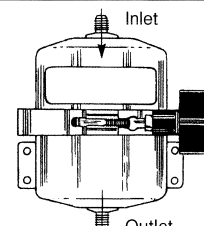

**1B** Inlet on top  
Outlet on bottom

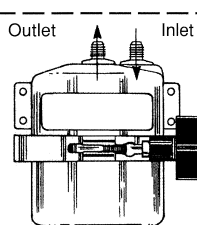

**1C** Inlet and Outlet on top

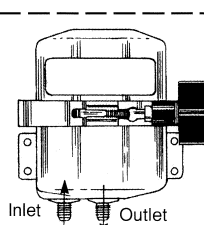

**1D** Outlet and Inlet on bottom

**Made In USA**

All health claims not in compliance with local or state laws are hereby withdrawn.

©1998, General Ecology, Inc.

®. TM Trademarks of General Ecology, Inc.

EPA Est. No 37403-PA01

200811-Rev.A

General Ecology, Inc.

the pure science of safe water™



151 Sheree Blvd., Exton, Pennsylvania 19341 USA

(610) 363-7900 • fax (610) 363-0412 • [www.general-ecology.com](http://www.general-ecology.com)





General Ecology's

# "Superior™" Series Microfiltration Cartridges for Aircraft "On Board" Drinking Water Systems

available for direct installation into the following housings:



General Ecology's  
Versa-Pure™ AC-2 and  
Seagull™ IV,  
Ogden AC-1, AT-1  
Ogden AC-2, BT  
S1B S1D XS1B  
S1E XS1 S1H

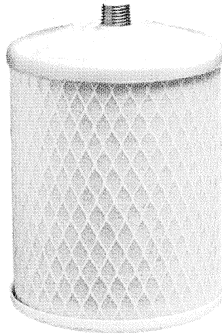

AL-15G REPLACEMENT CARTRIDGE  
(shown with brass threads)

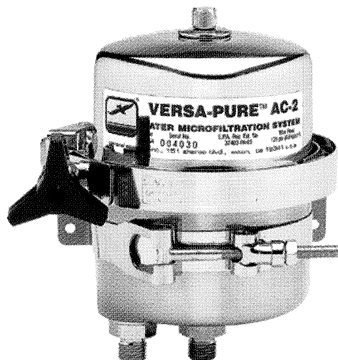

**GENERAL ECOLOGY Versa-Pure™ AC-2**  
Drinking Water Microfiltration System for  
Aircraft - Designed for utmost reliability,  
maximum capacity per unit space and low-  
est pressure drop. Polished stainless  
steel, available with mounting bracket for  
coffeemaker and direct galley installa-  
tions. Both SAE 37° JIC flare, and Mil Spec  
33514 E6 flareless fittings (shown above)  
are available.

(610) 363-7900 fax (610) 363-0412

General Ecology's microfiltration units and replacement cartridges employ ultrafine filtration to remove foul tastes and odors, organic pollutants, rust, dirt, some colloidal solids, amoebic and other cysts, algae and invisible particles down to the two to five micrometers range. General Ecology's microfiltered drinking water is fresh-tasting and delicious; ideal for beverage preparation. Formally accepted by the U.S. Public Health Service, Food and Drug Administration in November 1975, these products were rapidly established as industry leaders. Our "SUPERIOR" series cartridges feature the following enhancements:

- Higher reliability with more reserve capacity.
- Lower pressure drop—probably the lowest in the industry with only 0.2 psi at 1.2 gpm on the AL-15G cartridge.
- Greater chlorine and organic contaminant removal capacity with significantly more adsorption surface in each cartridge.
- Lower overall operating costs and economically priced.

## All of these outstanding advantages of our original airline cartridges have been retained:

- No carbon granule bleed-through experienced ordinarily with GAC cartridges.
- No asbestos, fiberglass nor vinyl ingredients.
- Monolithic, "Structured Matrix™" avoids channelling and loose granules. Clogged valves and fittings can cause expensive maintenance and even flight delays.
- Vibration resistant.
- Heat resistant, easily passing former F.D.A. heat soak standards for filters (CFR 121.2436).
- Many chemical pollutants in water combine with chlorine used to treat water, and form foul smelling, foul tasting, sometimes dangerous contaminant reaction products. General Ecology's Superior replacement cartridges remove significant quantities of these pollutants and reduce chlorine levels to fractional parts per million making the water fresh tasting and delicious. Just enough anti-microbial agent is left in the water to prevent recontamination of drinking water from internal bacteria growth common to ordinary charcoal filters. This is essential to continued problem-free operation. All components and ingredients have been F.D.A.-U.S.P.H.S. accepted.

### IMPORTANT:

For the very best quality drinking water use General Ecology's RS-15G "purification" cartridges in Versa Pure™ AC-2 pressure vessels. These remove everything the Superior Series removes, even more effectively AND protect against pathogenic cysts, bacteria and even specific viruses.

General Ecology, Inc. the pure science of safe water™

151 Sheree Boulevard, Exton, PA 19341



www.general-ecology.com e-mail: gecology@ix.netcom.com

## GENERAL ECOLOGY AIRLINE REPLACEMENT CARTRIDGES

-Description, operating characteristics and specifications.

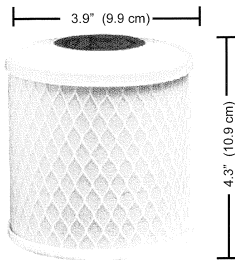

### AL-21SG - fits all General Ecology Versa-Pure® AC-2 Housings.\*

Pressure drop: 0.3 psi (.02 kg/cm<sup>2</sup>)  
 Rated service flow: 1 gpm (4 liters/m)  
 Rated capacity: 3800 gal. (14,000 liters)  
 Max. continuous operating temperature: 170°F (77°C)  
 Net weight: 1 lb (.45 kg)  
 Part Number: 770006  
 \*Order RS-1SG (P/N 778000) for cysts and bacteria protection in addition to taste and odor removal.

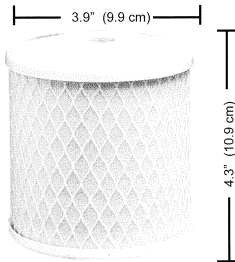

### AL-21OG-fits all Ogden AC-2 and BT Housings

Pressure drop: 0.3 psi (.02 kg/cm<sup>2</sup>)  
 Rated service flow: 1 gpm (4 liters/m)  
 Rated capacity: 3800 gal. (14,000 liters)  
 Max. continuous operating temperature: 170°F (77°C)  
 Net weight: 1 lb (.45 kg.)  
 Part Number: 770005

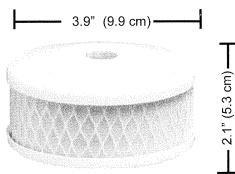

### AL-11OG - fits all Ogden AC-1 and AT-1 Housings

Pressure drop: 0.7 psi (0.5 kg/cm<sup>2</sup>)  
 Rated service flow: 0.5 gpm (2 liters/m)  
 Rated capacity: 1600 gal. (6000 liters)  
 Max. continuous operating temperature: 170°F (77°C)  
 Net weight: 0.5 lb (.22 kg)  
 Part Number: 770003

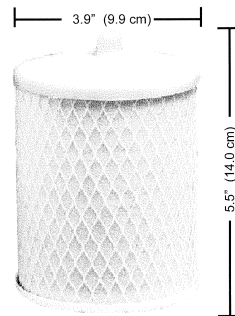

### AL-15G\*-fits all S1B, S1D, S1E, S1H, XS1 and XS1B Housings (shown with inert plastic threads)

\*Available with either inert plastic threads or with super durable brass threads.  
 Pressure drop: 0.2 psi (.02 kg/cm<sup>2</sup>)  
 Rated service flow: 1.3 gpm (5 liters/m)  
 Rated capacity: 5000 gal. (19,000 liters)  
 Max. continuous operating temperature: 170°F (77°C)  
 Net weight: 1.3 lb (.6 kg)  
 Part Number:(inert plastic threads) 770020  
 Part Number:(brass threads) 770021

## TYPICAL PRESSURE DROP VS. FLOW For Various General Ecology Airline Cartridges

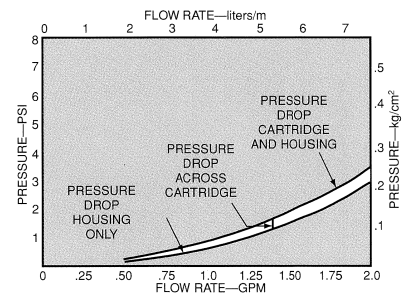
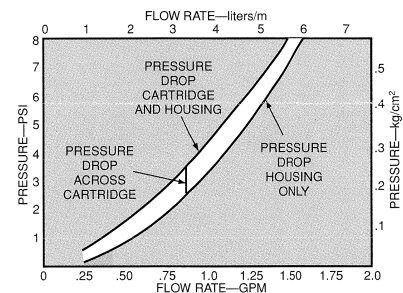
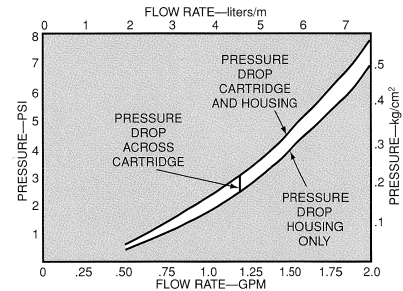
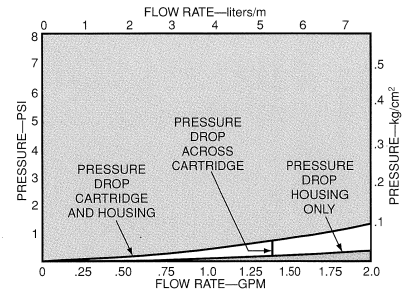

General Ecology has been privileged over the past several years to supply potable water purification and treatment equipment to dozens of major airlines and other customers in over 50 countries, and offers a complete line of products for both on-board and on-site service. Please let us know your water problems. For immediate service our technical, sales and customer service groups can be reached worldwide via fax, phone, or e-mail. Most products can be shipped in 24 hours or less. See current price lists for standard packaging, prices and other ordering information. Cartridge samples available upon request.

Printed and manufactured in U.S.A. ©1998 General Ecology, Inc. ®TM Reg. trademarks of General Ecology, Inc. All health claims not in accordance with local or state laws are hereby withdrawn. EPA Reg. No. 37403-PA-01

Please inquire about our **Trav-L®-Pure flight crew portable purifiers - certified to EPA "Purification" Standards.**



General Ecology, Inc.  
 151 Sheree Blvd.  
 Exton, PA 19341  
 (610) 363-7900 fax (610) 363-0412  
 Customer Service 1-800-441-8166

200600

**Our purifiers are world class - our customer service is even better!**



## **APPENDIX II**

### **Safety Data Sheet Lead Acid Battery**





# Safety Data Sheet

## 1. IDENTIFICATION

<b>Product Name:</b> Lead Acid Battery <b>Synonyms:</b> SLI Battery	<b>Product Use:</b> Vehicle Electrical System <b>Manufacturer/Supplier:</b> Johnson Controls Battery Group <b>Address:</b> P.O. Box 590 Milwaukee, WI 53201 US
<b>General Information Number:</b> (800)-333-2222 ext. 3138 <b>Contact Person:</b> Industrial Hygiene & Safety Department	<b>Emergency number:</b> CHEMTREC: 800-424-9300

**NOTE:** The Johnson Controls sealed cell/battery is considered an article as defined by 29 CFR 1910.1200 (OSHA Hazard Communication Standard). The information contained in this SDS is supplied at the customer's request for information only.

## 2. HAZARD(S) IDENTIFICATION

Health		Environmental	Physical
Acute Toxicity (Oral, dermal, inhalation)	Category 4	Aquatic Chronic 1 Aquatic Acute 1	Explosive Chemical, Division 1.3
Skin corrosion/irritation	Category 1A		
Eye Damage	Category 1		
Reproductive	Category 1A		
Carcinogenicity (lead)	Category 1B		
Carcinogenicity (acid mist)	Category 1A		
Specific target organ toxicity (repeated exposure)	Category 2		

### Label Elements:

Health	Environmental	Physical
<b>Hazard Statements</b> <b>DANGER!</b> Causes severe skin burns and eye damage. Causes serious eye damage. May damage fertility or the unborn child if ingested or inhaled. May cause cancer if ingested or inhaled. Causes damage to central nervous system, blood and kidneys through prolonged or repeated exposure.	<b>Precautionary Statements</b> Wash thoroughly after handling. Do not eat, drink or smoke when using this product. Wear protective gloves/protective clothing, eye protection/face protection. Avoid breathing dust/fume/gas/mist/vapors/spray. Use only outdoors or in a well-ventilated area. Causes skin irritation, serious eye damage. Contact with internal components may cause irritation or severe burns. Avoid contact with internal acid. Irritating to eyes, respiratory system, and skin.	

May form explosive air/gas mixture during charging. Extremely flammable gas (hydrogen). Explosive, fire, blast or projection hazard.	
--	--

### 3. COMPOSITION / INFORMATION ON INGREDIENTS

INGREDIENTS (Chemical/Common Names):	CAS No.:	% by Wt:
Lead	7439-92-1	34
Lead Oxide	1309-60-0	31
Sulfuric Acid	7664-93-9	34
Lead Sulfate	7446-14-2	<1

Composition Comments

All concentrations are in percent by weight.

### 4. FIRST AID MEASURES

**Note: Under normal conditions of battery use, internal components will not present a health hazard. The following information is provided for battery electrolyte (acid) and lead for exposures that may occur during battery production or container breakage or under extreme heat conditions such as fire.**

<b>Inhalation</b>	Sulfuric Acid: Remove to fresh air immediately. If not breathing, give artificial respiration. If breathing is difficult, give oxygen. Consult a physician. Lead: Remove from exposure, gargle, wash nose and lips; consult physician.
<b>Skin contact</b>	Sulfuric Acid: Flush with large amounts of water for at least 15 minutes; remove contaminated clothing completely, including shoes. If symptoms persist, seek medical attention. Wash contaminated clothing before reuse. Discard contaminated shoes. Lead: Wash immediately with soap and water.
<b>Eye contact</b>	Sulfuric Acid and Lead: Flush immediately with large amounts of water for at least 15 minutes while lifting lids; Seek immediate medical attention if eyes have been exposed directly to acid.
<b>Ingestion</b>	Sulfuric Acid: Give large quantities of water; Do NOT induce vomiting or aspiration into the lungs may occur and can cause permanent injury or death; consult physician. Lead: Consult physician immediately.

### 5. FIRE FIGHTING MEASURES

<b>Flash Point</b>	Not applicable unless individual components exposed.
<b>Auto ignition Temperature</b>	No data available.
<b>Flammable Limits</b>	LEL = 4.1% (Hydrogen Gas in air) ; UEL = 74.2%
<b>Extinguishing Media</b>	CO2; foam; dry chemical. Do not use carbon dioxide directly on cells. Avoid breathing vapors. Use appropriate media for surrounding fire.
<b>Special Fire Fighting Procedures</b>	Use positive pressure, self-contained breathing apparatus. Beware of acid splatter during water application and wear acid-resistant clothing, gloves, face and eye protection. If batteries are on charge, shut off power to the charging equipment, but note that strings of series connected batteries may still pose risk of electric shock even when charging equipment is shut down.
<b>Unusual Fire and Explosion Hazard</b>	Highly flammable hydrogen gas is generated during charging and operation of batteries. If ignited by burning cigarette, naked flame or spark, may cause battery explosion with dispersion of casing fragments and corrosive liquid electrolyte. Carefully follow manufacturer's instructions for installation and service. Keep away all sources of gas ignition and do not allow metallic articles to simultaneously contact the negative and positive terminals of a battery. Follow manufacturer's instructions for installation and service.

## 6: ACCIDENTAL RELEASE MEASURES

<b>Protective Measures to be Taken if Material is Released or Spilled</b>	Stop flow of material, contain/absorb small spills with dry sand, earth, and vermiculite. Do not use combustible materials. If possible, carefully neutralize spilled electrolyte with soda ash, sodium bicarbonate, lime, etc. Wear acid-resistant clothing, boots, gloves, and face shield. Do not allow discharge of un-neutralized acid to sewer. Acid must be managed in accordance with approved local, state, and federal requirements. Consult state environmental agency and/or federal EPA.
<b>Waste Disposal Method</b>	Dispose of as a hazardous waste. Dispose of in accordance with applicable local, state and federal regulations.

## 7. HANDLING AND STORAGE

<b>Handling</b>	Unless involved in recycling operations, do not breach the casing or empty the contents of the battery. Handle carefully and avoid tipping, which may allow electrolyte leakage. There may be increasing risk of electric shock from strings of connected batteries. Keep containers tightly closed when not in use. If battery case is broken, avoid contact with internal components. Keep vent caps on and cover terminals to prevent short circuits. Place cardboard between layers of stacked automotive batteries to avoid damage and short circuits. Keep away from combustible materials, organic chemicals, reducing substances, metals, strong oxidizers and water. Use banding or stretch wrap to secure items for shipping.
<b>Storage</b>	Store batteries under roof in cool, dry, well-ventilated areas separated from incompatible materials and from activities that may create flames, spark, or heat. Store on smooth, impervious surfaces provided with measures for liquid containment in the event of electrolyte spills. Keep away from metallic objects that could bridge the terminals on a battery and create a dangerous short-circuit. Room ventilation is required for batteries utilized for standby power generation. Never recharge batteries in an unventilated, enclosed space.
<b>Charging:</b>	There is a possible risk of electric shock from charging equipment and from strings of series connected batteries, whether or not being charged. Shut-off power to chargers whenever not in use and before detachment of any circuit connections. Batteries being charged will generate and release flammable hydrogen gas. Charging space should be ventilated. Keep battery vent caps in position. Prohibit smoking and avoid creation of flames and sparks nearby. Wear face and eye protection when near batteries being charged.
<b>Other</b>	Follow Manufacturers Recommendations regarding maximum recommended currents and operating temperature range. Do not overcharge beyond the recommended upper charging voltage limit. Applying pressure or deforming the battery may lead to disassembly followed by eye, skin and throat irritation.

## 8. EXPOSURE CONTROLS / PERSONAL PROTECTION

### Occupational exposure limits

#### US OSHA Specifically Regulated Substances (29 CFR 1910.1001 – 1050)

Ingredient	CAS Number	Type	Value
Lead	7439-92-1	TWA	0.05 mg/m <sup>3</sup>
Lead Oxide	1309-60-0	TWA	0.05 mg/m <sup>3</sup>
Lead Sulfate	7446-14-2	TWA	0.05 mg/m <sup>3</sup>

#### US OSHA Table Z-1 Limits for Air Contaminants (29CFR 1910.1000)

Ingredient	CAS Number	Type	Value
Sulfuric Acid	7664-93-9	PEL	1 mg/m <sup>3</sup>

#### US ACGIH Threshold Limit Values

Ingredient	CAS Number	Type	Value	Form
Lead	7439-92-1	TWA	0.05 mg/m <sup>3</sup>	
Lead Oxide	1309-60-0	TWA	0.05 mg/m <sup>3</sup>	
Lead Sulfate	7446-14-2	TWA	0.05 mg/m <sup>3</sup>	
Sulfuric Acid	7664-93-9	TWA	0.2 mg/m <sup>3</sup>	Thoracic Fractions

**US NIOSH: Pocket Guide to Chemical Hazards**

Ingredient	CAS Number	Type	Value
Lead	7439-92-1	TWA	0.05 mg/m <sup>3</sup>
Lead Oxide	1309-60-0	TWA	0.05 mg/m <sup>3</sup>
Sulfuric Acid	7664-93-9	TWA	1 mg/m <sup>3</sup>

**International Exposure Limits (mg/m<sup>3</sup>)**

*Chemical & Common Name	Quebec PEV	Ontario OEL	EU OEL
Lead and Lead Compounds (inorganic)	0.05	0.05	0.15 (a)
Electrolyte (H <sub>2</sub> SO <sub>4</sub> /H <sub>2</sub> O)	1	0.2	0.05 (b)

(a) As inhalable aerosol (b) Thoracic fraction

**Biological limit values****ACGIH Biological Exposure Indices**

Ingredient	Value	Determinant	Specimen	Sampling Time
Lead	300 µg/l	Lead	Blood	*
Lead Oxide	300 µg/l	Lead	Blood	*
Lead Sulfate	300 µg/l	Lead	Blood	*

\* - For Sampling details please see the source document.

**Engineering Controls (Ventilation):**

Store and handle in well-ventilated area. If mechanical ventilation is used, components must be acid-resistant. Handle batteries cautiously, do not tip to avoid spills. Make certain vent caps are on securely. If battery case is damaged, avoid bodily contact with internal components. Wear protective clothing, eye and face protection, when filling, charging, or handling batteries. Do not allow metallic materials to simultaneously contact both the positive and negative terminals of the batteries. Charge batteries in areas with adequate ventilation. General dilution ventilation is acceptable.

**Respiratory Protection (NIOSH/MSHA approved):**

NONE REQUIRED FOR NORMAL HANDLING OF THE FINISHED PRODUCT.

When concentrations of sulfuric acid mist are known to exceed PEL, use NIOSH or MSHA-approved respiratory protection.

**Skin Protection:**

NONE REQUIRED FOR NORMAL HANDLING OF THE FINISHED PRODUCT.

If battery case is damaged, use rubber or plastic acid-resistant gloves with elbow-length gauntlet, acid-resistant apron, clothing and boots.

**Eye Protection:**

NONE REQUIRED FOR NORMAL HANDLING OF THE FINISHED PRODUCT.

If necessary to handle damaged product where exposure to the organic electrolyte is a possibility, chemical splash goggles and a face shield are recommended.

**Other Protection:**

In areas where water and sulfuric acid solutions are handled in concentrations greater than 1%, emergency eyewash stations and showers should be provided, with unlimited water supply. Chemically impervious apron and face shield recommended when adding water or electrolyte to batteries. Wash Hands after handling.

**9. PHYSICAL AND CHEMICAL PROPERTIES**

<b>Appearance and Odor</b>	Manufactured article; no apparent odor. Electrolyte is a clear liquid with a sharp, penetrating, pungent odor.
<b>Odor Threshold</b>	Not applicable.
<b>pH</b>	Not applicable
<b>Boiling Point</b>	Not applicable unless individual components exposed.



	Battery Electrolyte (Acid) - 230 - 233.6 °F (110 - 112 °C)
	Lead - 3191 °F (1755 °C)
<b>Melting Point</b>	Lead - 621.32 °F (327.4 °C)
<b>Specific Gravity (H<sub>2</sub>O = 1)</b>	1.215 to 1.350
<b>Flash Point</b>	498.2 °F (259.0 °C) Hydrogen
<b>Evaporation Rate (Butyl Acetate = 1)</b>	< 1
<b>Vapor Pressure (mm Hg @ 20 ° C)</b>	Battery Electrolyte (Acid) 11.7
<b>Flammability</b>	
<b>Upper/lower flammability or explosive limits</b>	Hydrogen      Flammability Limit Lower- 4.1 % Flammability Limit Upper – 74.2 %
<b>Vapor Pressure</b>	Not applicable.
<b>Vapor Density</b>	3.4 (Air = 1) Battery Electrolyte (Acid)
<b>Relative Density</b>	1.21 - 1.3 Battery Electrolyte (Acid)
<b>Solubility</b>	Lead and Lead dioxide are not soluble. 100 % Battery Electrolyte (Acid).
<b>% Volatile by Weight</b>	Not applicable unless individual components exposed.
<b>Partition coefficient (n-octanol/water)</b>	Not applicable
<b>Auto-ignition temperature</b>	1076 °F (580 °C) Hydrogen.
<b>Decomposition temperature</b>	Not applicable
<b>Viscosity</b>	Not applicable

## 10. STABILITY AND REACTIVITY

<b>Stability</b>	The sealed battery is considered stable.
<b>Conditions to Avoid</b>	Sparks and other sources of ignition; high temperature; over charging.
<b>Incompatibility (materials to avoid)</b>	Electrolyte: Contact with combustibles and organic materials may cause fire and explosion. Also reacts violently with strong reducing agents, metals, sulfur trioxide gas, strong oxidizers, and water. Contact with metals may produce toxic sulfur dioxide fumes and may release flammable hydrogen gas.  Lead compounds: Avoid contact with strong acids, bases, halides, halogenates, potassium nitrate, permanganate, peroxides, nascent hydrogen, and reducing agents.  Arsenic compounds: strong oxidizers; bromine azide. NOTE: hydrogen gas can react with inorganic arsenic to form the highly toxic gas – arsine
<b>Hazardous Decomposition Products</b>	Electrolyte: Sulfur trioxide, carbon monoxide, sulfuric acid mist, sulfur dioxide, hydrogen sulfide.  Lead compounds: Temperatures above the melting point are likely to produce toxic metal fume, vapor, or dust; contact with strong acid or base or presence of nascent hydrogen may generate highly toxic arsine gas.
<b>Hazardous Polymerization</b>	Will not occur.

## 11. TOXICOLOGICAL INFORMATION

**NOTE: Under normal conditions of use, this product does not present a health hazard. The following information is provided for organic electrolyte and lead exposure that may occur due to container breakage or under extreme conditions such as fire. Organic electrolyte – reacts with moisture/water to produce hydrofluoric acid in trace quantities. Hydrofluoric acid is extremely corrosive and toxic. In severe exposures it acts as a systemic poison and causes severe burns. The reaction may be delayed. Any contact with this material, even minor, requires immediate medical attention.**

#### ROUTES AND METHODS OF ENTRY

<b>Inhalation</b>	<b>EXPOSURE IS NOT EXPECTED FOR PRODUCT UNDER NORMAL CONDITIONS OF USE.</b>  Sulfuric Acid: Breathing of sulfuric acid vapors or mists may cause severe respiratory irritation. Lead Compounds: Inhalation of lead dust or fumes may cause irritation of upper respiratory tract and lungs.
<b>Skin Contact</b>	<b>EXPOSURE IS NOT EXPECTED FOR PRODUCT UNDER NORMAL CONDITIONS OF USE.</b>  Sulfuric Acid: Severe irritation, burns and ulceration. Lead Compounds: Not absorbed through the skin.
<b>Skin Absorption</b>	<b>EXPOSURE IS NOT EXPECTED FOR PRODUCT UNDER NORMAL CONDITIONS OF USE.</b>  In the event of overcharging or damage to the unit, exposure to organic electrolyte solution/mist is possible. Extreme exposures to the organic electrolyte can be absorbed through the skin.
<b>Eye Contact</b>	<b>EXPOSURE IS NOT EXPECTED FOR PRODUCT UNDER NORMAL CONDITIONS OF USE.</b>  Sulfuric Acid: Severe irritation, burns, cornea damage, and blindness. Lead Compounds: May cause eye irritation.
<b>Ingestion</b>	<b>EXPOSURE IS NOT EXPECTED FOR PRODUCT UNDER NORMAL CONDITIONS OF USE.</b>  Sulfuric Acid: May cause severe irritation of mouth, throat, esophagus and stomach. Lead Compounds: Acute ingestion may cause abdominal pain, nausea, vomiting, diarrhea and severe cramping. This may lead rapidly to systemic toxicity and must be treated by a physician.

#### SIGNS AND SYMPTOMS OF OVEREXPOSURE

<b>Acute Effects</b>	<b>EXPOSURE IS NOT EXPECTED FOR PRODUCT UNDER NORMAL CONDITIONS OF USE.</b>  Sulfuric Acid: Severe skin irritation, damage to cornea, upper respiratory irritation. Lead Compounds: Symptoms of toxicity include headache, fatigue, abdominal pain, loss of appetite, muscular aches and weakness, sleep disturbances and irritability
<b>Chronic Effects</b>	<b>EXPOSURE IS NOT EXPECTED FOR PRODUCT UNDER NORMAL CONDITIONS OF USE.</b>  Sulfuric Acid: Possible erosion of tooth enamel, inflammation of nose, throat & bronchial tubes. Lead Compounds: Anemia; neuropathy, particularly of the motor nerves, with wrist drop; kidney damage; reproductive changes in males and females. Repeated exposure to lead and lead compounds in the workplace may result in nervous system toxicity. Some toxicologists report abnormal conduction velocities in persons with blood lead levels of 50 µg/100 ml or higher. Heavy lead exposure may result in central nervous system damage, encephalopathy and damage to the blood-forming (hematopoietic) tissues.

#### MEDICAL CONDITIONS AGGRAVATED BY EXPOSURE

Overexposure to sulfuric acid mist may cause lung damage and aggravate pulmonary conditions. Contact of sulfuric acid with skin may aggravate diseases such as eczema and contact dermatitis. Lead and its compounds can aggravate some forms of kidney, liver and neurologic diseases.

#### ADDITIONAL HEALTH DATA

All heavy metals, including the hazardous ingredients in this product, are taken into the body primarily by inhalation and ingestion. Most inhalation problems can be avoided by adequate precautions such as ventilation and respiratory protection covered in Section 8. Follow good personal hygiene to avoid inhalation and ingestion: wash hands, face, neck and arms thoroughly before eating, smoking or leaving the work site. Keep contaminated clothing out of non-contaminated areas, or wear cover clothing when in such areas. Restrict the use and presence of food, tobacco and cosmetics to non-contaminated areas. Work clothes and work equipment used in contaminated areas must remain in designated areas and never taken home or laundered with personal non-contaminated clothing. This product is intended for industrial use only and should be isolated from children and their environment.

The 19th Amendment to EC Directive 67/548/EEC classified lead compounds, but not lead in metal form, as possibly toxic to reproduction. Risk phrase 61: May cause harm to the unborn child, applies to lead compounds, especially soluble forms.

#### Toxicological Data

Constituents	Species	Test Results
PS-HTR-ST-43-E_Lead Acid Battery		SDS US
Version #: 05 Issue Date: 04/01/2015 Revision Date: 03/16/2017		6 of 11

Sulfuric Acid (CAS 7664-93-9)

**Acute**

*Oral*

LD50

Rat

2140 mg/kg

**CARCINOGENICITY**

Sulfuric Acid: The International Agency for Research on Cancer (IARC) has classified "strong inorganic acid mist containing sulfuric acid" as a Category I carcinogen, a substance that is carcinogenic to humans. This classification does not apply to liquid forms of sulfuric acid or sulfuric acid solutions contained within a battery. Inorganic acid mist (sulfuric acid mist) is not generated under normal use of this product. Misuse of the product, such as overcharging, may result in the generation of sulfuric acid mist.

Lead Compounds: Lead is listed as a Group 2A- carcinogen, likely in animals at extreme doses. Per the guidance found in OSHA 29 CFR 1910.1200 Appendix F, this is approximately equivalent to GHS Category 1A. Proof of carcinogenicity in humans is lacking at present.

**IARC Monographs. Overall Evaluation of Carcinogenicity**

Lead (CAS 7439-92-1)

2A Probably carcinogenic to humans.

Lead oxide (CAS 1309-60-0)

2A Probably carcinogenic to humans.

Lead sulfate (CAS 7446-14-2)

2A Probably carcinogenic to humans.

**NTP Report on Carcinogens**

Lead oxide (CAS 1309-60-0)

Reasonably Anticipated to be a Human Carcinogen.

Lead sulfate (CAS 7446-14-2)

Reasonably Anticipated to be a Human Carcinogen.

**OSHA Specifically Regulated Substances (29 CFR 1910.1001-1050)**

Not listed.

**Reproductive toxicity**

May damage fertility or the unborn child.

**Specific target organ**

No data available.

**toxicity -**

**single exposure**

**Specific target organ**

Lead: May cause damage to organs (blood, central nervous system) through prolonged or repeated exposure.

**toxicity -**

**repeated exposure**

**Aspiration hazard**

Not classified.

**12. ECOLOGICAL INFORMATION**

**Environmental Fate**

Lead is very persistent in soil and sediments. No data on environmental degradation. Mobility of metallic lead between ecological compartments is slow. Bioaccumulation of lead occurs in aquatic and terrestrial animals and plants but little bioaccumulation occurs through the food chain. Most studies include lead compounds and not elemental lead

**Environmental toxicity**

Aquatic Toxicity:

Sulfuric Acid

24-hr LC50, freshwater fish (Brachydanio rerio): 82 mg/L

96 hr- LOEC, freshwater fish (Cyprinus carpio): 22 mg/L

Lead

48 hr LC50 (modeled for aquatic invertebrates): <1 mg/L, based on lead bullion

**Additional Information**

No known effects on stratospheric ozone depletion

Volatile organic compounds: 0% (by Volume)

Water Endangering Class (WGK): NA

**13. DISPOSAL CONSIDERATIONS**

**Waste disposal method**

Material should be recycled if possible. Lead-acid batteries are completely recyclable. Dispose waste and residues in accordance with applicable federal, state, and local regulations.

**Hazardous waste code**

D008: Lead

**Waste from residues /  
unused products**

Dispose of in accordance with local regulations. Empty containers or packaging may retain some product residues. This material and its container must be disposed of in a safe manner (see: Disposal instructions).

**Contaminated packaging** Empty containers should be taken to an approved waste handling site for recycling or disposal.

## 14. TRANSPORT INFORMATION

**Note: Transportation requirements do not apply once the battery pack has been installed in a vehicle as part of the vehicle's functional components.**

### United States DOT:

DOT rules specified in 49 CFR 173.159 regulate the transport of wet spillable batteries.

49 CFR 173.159 (e) specifies that when transported by highway or rail, electric storage batteries containing electrolyte or corrosive battery fluid are not subject to any other requirements of this subchapter, if all of the following are met:

- (1) No other hazardous materials may be transported in the same vehicle;
- (2) The batteries must be loaded or braced so as to prevent damage and short circuits in transit;
- (3) Any other material loaded in the same vehicle must be blocked, braced, or otherwise secured to prevent contact with or damage to the batteries; and
- (4) The transport vehicle may not carry material shipped by any person other than the shipper of the batteries.

If any of these requirements are not met, the batteries must be shipped as hazardous materials

### GROUND – US-DOT/CAN-TDG/EU-ADR/APEC-ADR:

<b>Proper Shipping name</b>	Batteries, Wet, Filled with Acid
<b>UN number</b>	UN2794
<b>Hazard classification</b>	8
<b>Packing group</b>	N/A
<b>Labels</b>	Corrosive

### AIRCRAFT – ICAO-IATA:

<b>Proper Shipping name</b>	Batteries, Wet, Filled with Acid
<b>Packing group</b>	None
<b>Hazardous class</b>	8
<b>Label/Placard Required</b>	Corrosive
<b>UN Identification</b>	UN2794
<b>Environmental Hazards</b>	No
<b>ERG Code</b>	8L
<b>Reference</b>	IATA packing instructions 870 (IATA DRG Edition 54)

### VESSEL – IMO-IMDG:

<b>Proper Shipping name</b>	Batteries, Wet, Filled with Acid
<b>Packing group</b>	N/A
<b>Hazardous class</b>	8
<b>Label/Placard Required</b>	Corrosive
<b>UN Identification</b>	UN2794
<b>Environmental Hazards</b>	No
<b>EmS</b>	F-A, S-B
<b>Reference</b>	IMDG packing instructions P801

## 15. REGULATORY INFORMATION

This product is an article pursuant to 29 CFR 1910.1200 and as such is not subjected to the OSHA Hazard Communication Standard.

### TSCA

#### TSCA Section 8b – Inventory Status:

Inventory Status: All chemicals comprising this product are either exempt or listed on the TSCA Inventory.

#### TSCA Section 12b (40 CFR Part 707.60(b))

No notice of export will be required for articles, except PCB articles, unless the Agency so requires in the context of individual section 5, 6, or 7 actions.

**TSCA Section 13 (40 CFR Part 707.20)**

No import certification required (EPA 305-B-99-001, June 1999, Introduction to the Chemical Import Requirements of the Toxic Substances Control Act, Section IV.A)

**OSHA Specifically Regulated Substances (29 CFR 1910.1001-1050)**

Lead (CAS 7439-92-1)	Reproductive toxicity Central nervous system Kidney Blood
Lead Oxide (CAS 1309-60-0)	Acute toxicity Reproductive toxicity Central nervous system Kidney Blood
Lead Sulfate (CAS 7446-14-2)	Acute toxicity Reproductive toxicity Central nervous system Kidney Blood Acute toxicity

**EPA SARA Title III****Section 302 EPCRA Extremely Hazardous Substances (EHS):**

Sulfuric acid is a listed "Extremely Hazardous Substance" under EPCRA, with a Threshold Planning Quantity (TPQ) of 1,000 lbs. EPCRA Section 302 notification is required if 500 lbs. or more of sulfuric acid is present at one site (40 CFR 370.10). For more information consult 40 CFR Part 355.

**Section 304 CERCLA Hazardous Substances:**

Reportable Quantity (RQ) for spilled 100% sulfuric acid under CERCLA (Superfund) and EPCRA (Emergency Planning and Community Right to Know Act) is 1,000 lbs. State and local reportable quantities for spilled sulfuric acid may vary.

**Section 311/312 Hazard Categorization:**

EPCRA Section 312 Tier Two reporting is required for non-automotive batteries if sulfuric acid is present in quantities of 500 lbs. or more and/or if lead is present in quantities of 10,000 lbs. or more. For more information consult 40 CFR 370.10 and 40 CFR 370.40

**Section 313 EPCRA Toxic Substances:**

40 cfr section 372.38 (b) states: If a toxic chemical is present in an article at a covered facility, a person is not required to consider the quantity of the toxic chemical present in such article when determining whether an applicable threshold has been met under § 372.25, § 372.27, or § 372.28 or determining the amount of release to be reported under § 372.30. This exemption applies whether the person received the article from another person or the person produced the article. However, this exemption applies only to the quantity of the toxic chemical present in the article.

**Supplier Notification:**

This product contains toxic chemicals that may be reportable under EPCRA Section 313 Toxic Chemical Release Inventory (Form R) requirements. For a manufacturing facility under SIC codes 20 through 39, the following information is provided to enable you to complete the required reports:

**RCRA**

Spent Lead Acid Batteries are subject to streamlined handling requirements when managed in compliance with 40 CFR section 266.80 or 40 CFR part 273. Waste sulfuric acid is a characteristic hazardous waste; EPA hazardous waste number D002 (corrosivity) and D008 (lead).

**Other federal regulations****Clean Air Act (CAA) Section 112 Hazardous Air Pollutants (HAPs) List**

Lead (CAS 7439-92-1)  
Lead Oxide (CAS 1309-60-0)  
Lead Sulfate (CAS 7446-14-2)

**Clean Air Act (CAA) Section 112(r) Accidental Release Prevention (40 CFR 68.130)**

Lead Sulfate (CAS 7446-14-2)

**Safe Drinking Water Act (SDWA)**

Not regulated

**Drug Enforcement Administration (DEA). List 2, Essential Chemicals (21 CFR 1310.02(b) and 1310.04(f)(2) and Chemical Code Number**

Sulfuric acid (CAS 7664-93-9) 6552

**Drug Enforcement Administration (DEA). List 1 & 2 Exempt Chemical Mixtures (21 CFR 1310.12(c))**

Sulfuric acid (CAS 7664-93-9) 20 % WV

**DEA Exempt Chemical Mixtures Code Number**

Sulfuric acid (CAS 7664-93-9) 6552

**US State Regulations**

**US. Massachusetts RTK – Substance List**

Lead ( CAS 7439-92-1)

Lead Oxide (CAS 1309-60-0)

Lead Sulfate (CAS 7446-14-2)

**US New Jersey Worker and Community Right-to-know Act**

Lead ( CAS 7439-92-1)

Lead Oxide (CAS 1309-60-0)

Lead Sulfate (CAS 7446-14-2)

Sulfuric acid (CAS 7664-93-9)

**US Pennsylvania Worker and Community Right-to-know Law**

Lead ( CAS 7439-92-1)

Sulfuric acid (CAS 7664-93-9)

**US Rhode Island RTK**

Lead ( CAS 7439-92-1)

Lead Oxide (CAS 1309-60-0)

Lead Sulfate (CAS 7446-14-2)

Sulfuric acid (CAS 7664-93-9)

**US. California Proposition 65**

WARNING: This product contains chemicals known to the State of California to cause cancer.

Battery posts, terminals and related accessories contain lead and lead compounds, chemicals known to the state of California to cause cancer and reproductive harm. Wash hands after handling.

\*Battery companies not party to the 1999 consent judgment with Mateel Environmental Justice Foundation should include a Proposition 65 Warning that complies with the current version of Proposition 65.

**US - California Proposition 65 - Carcinogens & Reproductive Toxicity (CRT): Listed substance**

Lead ( CAS 7439-92-1)

Lead Oxide (CAS 1309-60-0)

Lead Sulfate (CAS 7446-14-2)

Sulfuric acid (CAS 7664-93-9)

**International Inventories**

Country(s) or Region	Inventory Name	On inventory (yes/no)*
United States & Puerto Rico	Toxic Substances Control Act (TSCA) Inventory	Yes

\* A "Yes" indicates this product complies with the inventory requirements administered by the governing country(s).

A "No" indicates that one or more components of the product are not listed or exempt from listing on the inventory administered by the governing country(s).

**CANADIAN ENVIRONMENTAL PROTECTION ACT:** These products are manufactured articles and are exempt from regulation.

**CANADIAN WHMIS CLASSIFICATION:** This product has been classified according to the hazard criteria of the CPR and the MSDS contains all the information required by the CPR.

## 16. OTHER INFORMATION

**Issue Date:** 04/01/2015

**Further information:** NFPA Hazard Scale: 0 = Minimal 1 = Slight 2 = Moderate 3=Serious 4 = Severe

**NFPA ratings**

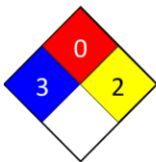

**Disclaimer**

Johnson Controls Battery Group, Inc. cannot anticipate all conditions under which this information and its product, or the products of other manufacturers in combination with its product, may be used. It is the user's responsibility to ensure safe conditions for handling, storage and disposal of the product, and to assume liability for loss, injury, damage or expense due to improper use. The information in the sheet was written based on the best knowledge and experience currently available.