

Model: 20-4525-0000
Four Cylinder Tiltable Oxygen Cart
with Manifold/Regulator



12/2018 - Rev. 03



CAUTION

It is **MANDATORY** that this instruction manual be read and understood by all persons operating this High Pressure Oxygen Cart.

REVISION	DATE	TEXT AFFECTED
01	11/2013	Original release
02	11/2018	Major revision
03	12/2018	Modified Parts List

TABLE OF CONTENTS**PAGE**

1.0	PRODUCT INFORMATION	1
1.1	DESCRIPTION.....	1
1.2	MODEL & SERIAL NUMBER.....	1
1.3	MANUFACTURER.....	1
1.4	SPECIFICATIONS/FEATURES	1
2.0	SAFETY INFORMATION.....	3
2.1	USAGE AND SAFETY INFORMATION.....	3
2.2	SAFETY INSTRUCTIONS	3
2.3	GENERAL.....	3
2.4	SAFETY.....	3
3.0	PREPARATION FOR USE	4
3.1	LOADING/UNLOADING CYLINDERS	4
3.1.1	Loading Cylinders	4
3.1.2	Unloading Cylinders	4
3.2	SCHEMATIC	4
4.0	TRAINING.....	5
4.1	TRAINING REQUIREMENTS	5
4.2	TRAINING PROGRAM	5
4.3	OPERATOR TRAINING	5
5.0	OPERATION.....	5
6.0	PACKAGING AND STORAGE	5
6.1	STORAGE	5
7.0	TROUBLESHOOTING	5
8.0	MAINTENANCE.....	6
8.1	TRAILER:.....	6
8.2	OXYGEN COMPONENTS:	6
9.0	PROVISION OF SPARES.....	6
9.1	SOURCE OF SPARE PARTS.....	6
9.2	RECOMMENDED SPARE PARTS LISTS	6
10.0	IN SERVICE SUPPORT.....	6
11.0	GUARANTEES/LIMITATION OF LIABILITY	7
12.0	APPENDICES	7

This product can not be modified without the written approval of Tronair, Inc. Any modifications done without written approval voids all warranties and releases Tronair, Inc., its suppliers, distributors, employees, or financial institutions from any liability from consequences that may occur. Only Tronair OEM replacement parts shall be used.

**CAUTION!**

It is **MANDATORY** that this instruction manual be read and understood by all persons operating this Oxygen Cart.

1.0 PRODUCT INFORMATION**1.1 DESCRIPTION**

The Tronair Four Cylinder Cart is designed to minimize the handling of oxygen cylinders in loading, transporting and servicing process and to provide boosted compressed gas for an aircraft.

The high pressure regulator is for regulating output pressure from 15 - 2250 psi (115 bar).

The transport cart allows a single operator to load full oxygen cylinders and transport them to service the aircraft, without ever having to lift the cylinders. The unique quality of this cart is the operator never has to lift a cylinder, which can weigh between 120 and 175 lbs., onto the cart. The cart has a very narrow footprint and a tight turning radius allowing for easy maneuverability.

Cart may be used to supply either internal aircraft systems or portable aircraft bottles.

**DANGER!**

TO AVOID SERIOUS INJURY, LOSS OF LIMB OR DEATH:

- 1. DO NOT use on LOW PRESSURE aircraft systems.**
- 2. DO NOT use with ANY GAS OTHER THAN OXYGEN.**
- 3. DO NOT exceed 2250 PSIG inlet oxygen bottle pressure.**
- 4. All components used in the oxygen system shall be clean, dry and free of all contamination per SAE SPEC. AIR 1176.**
- 5. Servicing and/or maintenance of oxygen systems shall be done by trained and qualified personnel using approved procedures per SAE SPEC. ARP 1532.**

1.2 MODEL & SERIAL NUMBER

Reference nameplate on unit

1.3 MANUFACTURER

TRONAIR, Inc.
1 Air Cargo Pkwy East
Swanton, Ohio 43558 USA

Telephone: (419) 866-6301 or 800-426-6301
Fax: (419) 867-0634
E-mail: sales@tronair.com
Website: www.tronair.com

1.4 SPECIFICATIONS/FEATURES**Dimensions:**

- Height: 46 11/16 in (118.58 cm)
- Length: 92 13/16 in (235.74 cm)
- Width: 35 13/16 in (90.96 cm)
- Weight: 564 lbs (256 kg)

Rotating Cylinder Loader/Un-Loader:

- Stable and efficient rotational motion guidance under variable weights, speeds and high load conditions keeping the cylinders in the correct location
- Struts control the rotating of the cylinders from the vertical and horizontal positions
- Accommodates cylinders 9 - 3/4", 56" tall and weighing less than 150 lbs
- Manufactured of high strength materials to ensure the cylinders are secure
- Locks into horizontal or vertical position by a spring loaded plunger
- M

1.4 SPECIFICATIONS/FEATURES *(continued)***Cart:**

- CE Marked
- Easy, one person loading/unloading
- Use with 9 - 3/4" , 56" tall and weighing less than 150 lbs oxygen cylinders; CGA 540 connection with check valves, 3000 psi max
- Cylinders fully captured
- Pneumatic tires/tapered wheel bearings
- Narrow width
- Very low profile, fits under most aircraft wings
- Parking brake
- Hose compartment storage tray
- Instrument Panel
- Powder coated heavy duty steel construction
- Compact frame allows for a tight turning radius

High Pressure Regulator:

- 25-4000 psi (1.7-275.8 bar) rated output
- 15 ft (4.6 m) service hose

Temperature Range:

- 0° to 200°F (17.7° to 93.3° C)

2.0 SAFETY INFORMATION

2.1 USAGE AND SAFETY INFORMATION

To insure safe operations please read the following statements and understand their meaning. Also refer to your equipment manufacturer's manual for other important safety information. This manual contains safety precautions which are explained below. Please read carefully.



WARNING!

Warning is used to indicate the presence of a hazard that can cause **severe personal injury, death, and/or substantial property damage** if the Warning Notice is ignored.

CAUTION!

Caution is used to indicate the presence of a hazard, which will or can cause **minor personal injury or property damage** if the Caution Notice is ignored.

2.2 SAFETY INSTRUCTIONS



CAUTION!

It is mandatory that this instruction manual be read and understood by all persons operating this Oxygen Cart.

2.3 GENERAL

Information presented in this manual and on various labels, tags, and plates on the unit pertains to equipment design, installation, operation, maintenance and trouble shooting which should be read, understood, and followed for the safe and effective use of this equipment.

2.4 SAFETY

The operation, maintenance, and trouble shooting of this high pressure oxygen booster requires practices and procedures which ensure personal operator safety and the safety of others. Therefore, this equipment is to be operated and maintained only by qualified persons in accordance with this manual and all applicable local codes.

NOTE: Safety instructions specifically pertaining to this unit appear throughout this manual highlighted by the signal words *WARNING, CAUTION, DANGER* which identify different levels of hazard.



WARNING!

TO AVOID SERIOUS INJURY OR DEATH OBSERVE THE FOLLOWING:

1. All components used in the oxygen system must be clean, dry, and free of all contamination per SAE SPEC AIR 1176.
2. DO NOT use this equipment with nitrogen or gas other than oxygen.
3. DO NOT exceed 2250 psig bottle inlet pressure.
4. Servicing and maintenance of the system should only be done by trained and qualified personnel using approved procedures.
5. It is mandatory that this instruction manual be read and understood by all persons operating this oxygen manifold.

Pressures: Gases under pressure are a potential hazard in the form of stored energy. Accidents can occur when this energy is improperly handled. Be sure that all equipment used is compatible and designed to control the pressures encountered.

Oxygen: Oxygen is an oxidizing gas and is chemically stable and nonflammable. However, oxygen does support combustion. High concentrations can accelerate the combustion of flammable materials up to and including an explosion. It is important to understand that spontaneous combustion of organic materials can occur in oxygen rich atmospheres.

Handling: Oxygen handling must be done with care to avoid any association with hydro-carbons, especially where fuels and lubricants are present in aircraft service areas. It is imperative that oxygen systems be handled properly. Be sure to keep all protective caps in position on equipment as long as possible, and replace them as soon as possible.

Velocity: Oxygen flowing at a high velocity in a piping system can propel any foreign material particles with such force that the impact friction can raise the particles temperature to a possible ignition point. It is, therefore, imperative that a high degree of cleanliness be maintained in the oxygen system at all times.

Oxygen Servicing: The following list contains additional general safety precautions that should be adhered to during the servicing process. However, always refer to the manufacturer's procedure for the airplane being serviced.

1. Always ground the system to be serviced and the servicing equipment before connecting the filler adapter.
2. Close the oxygen bottle manual shutoff valve.
3. Ensure that all aircraft electrical power is off. Do not operate electrical switches, or connect or disconnect ground power generators during the oxygen charging operation.
4. Do not service the oxygen system if fueling or other flammable fluid servicing is in process.
5. Do not charge the system too fast. Rapid charging can create a dangerous overheating condition.

SAE AIRCRAFT OXYGEN SPECIFICATION INFORMATION

For more information concerning specific SAE aircraft oxygen equipment specifications, contact: Society of Automotive Engineers, 400 Commonwealth Drive, Warrendale, PA 15096-0001

3.0 PREPARATION FOR USE



CAUTION!
Only use cylinders for which this unit was designed: 9 – 9 ¾ inch diameter, 2250 psig (155 bar) maximum pressure with CGA 540 connection.



CAUTION!
Maximum towing speed is 10 mph (16 km/h).

3.1 LOADING/UNLOADING CYLINDERS

3.1.1 Loading Cylinders



WARNING!
This cart is designed to carry 4 cylinders simultaneously. Failure to install all 4 cylinders will create an unstable condition. Cart must be fully loaded/unloaded before transporting.



CAUTION!
Do NOT transport cart with cradles in upright position. Always store cradles in horizontal position.

1. Place cart on flat, level surface
2. Ensure Towbar is in upright position
3. Rotate both cylinder cradles to upright position (empty cradles will require assistance to move into position), ensure locking mechanism is engaged
4. Lower bottom ramp
5. Remove bottom clamping handle assembly
6. Loosen only one top clamping knob and rotate strap away from cradle
7. Walk cylinder up ramp and into cradle, position cylinder valve outlet port to face directly forward, toward towbar
8. Rotate strap against cylinder and tighten top clamping knob
9. Repeat steps 6-8 for second cylinder
10. Install bottom clamping handle assembly and tighten
11. Raise bottom ramp into upright position and click into place
12. Repeat steps 6-11 for cylinders on opposite side
13. all fours are rotate cradles to horizontal position. Ensure locking mechanism is engaged
14. Attach 4 input hoses to cylinders

3.1.2 Unloading Cylinders



WARNING!
This cart is designed to carry 4 cylinders simultaneously. Failure to install all 4 cylinders will create an unstable condition. Cart must be fully loaded/unloaded before transporting.



CAUTION!
Do NOT transport cart with cradles in upright position. Always store cradles in horizontal position.

1. Place cart on flat, level surface
2. Ensure Towbar is in upright position
3. Close cylinder valves and disconnect input hoses
4. Rotate both cylinder cradles to upright position, ensure locking mechanism is engaged
5. Lower bottom ramp
6. Remove bottom clamping handle assembly
7. Loosen only one top clamping knob and rotate strap away from cradle
8. Walk cylinder down ramp
9. Repeat steps 7 & 8 for second cylinder
10. Repeat steps 5-8 for cylinders on opposite side

3.2 SCHEMATIC

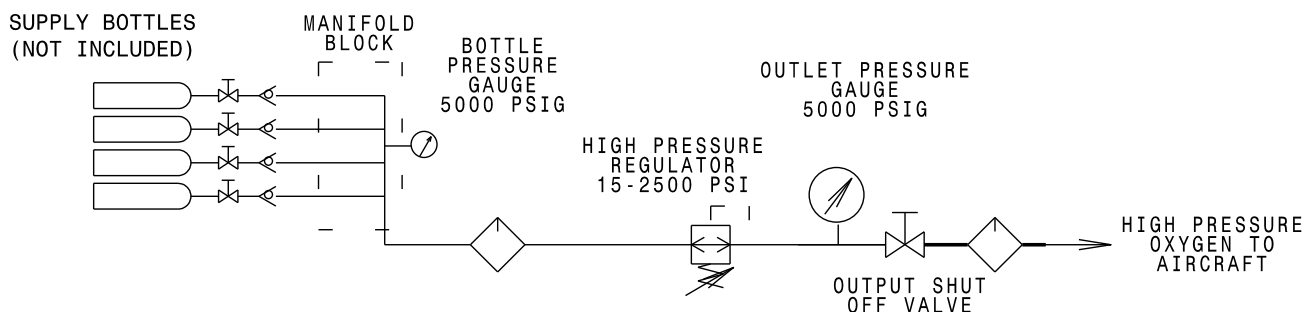

4.0 TRAINING

4.1 TRAINING REQUIREMENTS

The employer of the operator is responsible for providing a training program sufficient for the safe operation of the unit.

4.2 TRAINING PROGRAM

The employer provided operator training program should cover safety procedures concerning use of the unit in and around the intended aircraft at the intended aircraft servicing location.

4.3 OPERATOR TRAINING

The operator training should provide the required training for safe operation of the unit.

NOTE: Maintenance and Trouble Shooting are to be performed by a skilled and trained technician.

5.0 OPERATION

WARNING!



If there are any differences between the following instructions and the aircraft maintenance manual, the aircraft maintenance manual will take precedence.

1. Close outlet shutoff valve (clockwise) and reduce pressure regulator (counterclockwise).
2. Connect outlet hose **loosely** to aircraft oxygen service fitting.

WARNING!



Be sure outlet hose is engaged sufficiently prior to purging in order to prevent disengagement and whipping of hose end.

3. Slowly open the bottle shutoff valve and adjust the pressure regulator to approximately 75 psi.
4. Slowly open outlet shutoff valve sufficiently to purge hose. Close outlet shutoff valve.
5. Securely tighten outlet hose fitting at aircraft.
6. Adjust pressure regulator to desired pressure.
7. Open outlet shutoff valve to service aircraft in accordance with aircraft maintenance recommendations.
8. After aircraft service completion, close oxygen bottle shutoff valve.
9. Close outlet shutoff valve and back off pressure regulator.
10. Bleed down outlet hose by slowly loosening outlet hose fitting at aircraft. Disconnect and properly store outlet hose.

To Read Individual Bottle Pressure:

1. Close outlet shut off valve.
2. Open a bottle shutoff valve.
3. Read pressure on manifold pressure gauge.
4. Close bottle shutoff valve.
5. Open outlet shutoff valve and slightly adjust pressure regulator to bleed off manifold pressure.
6. Repeat procedure for other bottles.

Efficient Use of System:

Maximum oxygen may be removed from supply bottles if aircraft are serviced from the lowest pressure bottle first. In this manner, the most oxygen may be removed from each bottle. Even bottles with relatively low pressures may be used to service aircraft if the aircraft has a depleted system (250 psi minimum).

6.0 PACKAGING AND STORAGE

6.1 STORAGE

- Store the unit in a clean, dry area when not in use.
- Be sure that all hoses are capped and the unit is covered with lint free covering for the duration of unit storage to ensure complete oxygen system cleanliness for future aircraft system recharging.

7.0 TROUBLESHOOTING

Refer to Appendix I and Appendix II

8.0 MAINTENANCE

The operation, maintenance, and trouble shooting of this unit require practices and procedures, which ensure personal operator safety and the safety of others. Therefore, this equipment is to be operated and maintained only by qualified persons in accordance with this manual and all applicable local codes. Maintenance is only to be done by qualified persons.

All maintenance personnel must be familiar with the cautions and warnings associated with high pressure oxygen and high pressure oxygen systems as outlined in *Section 3 - Safety* of this manual prior to performing any maintenance on the unit.

8.1 TRAILER:

- Maintain pressure listed on tires.
- Grease wheel bearings quarterly.
- Generally, keep the entire unit clean and free from contaminants. Visually inspect for any system leaks or damage. Correction of any problems prior to unit operation is imperative for safe operation.

8.2 OXYGEN COMPONENTS:

WARNING!



OXYGEN EQUIPMENT IS NOT FIELD OR CUSTOMER SERVICEABLE!
OEM repair or replacement is recommended.

- The gauges on this unit should be inspected and calibrated annually to ANSI grade A accuracy, to maintain and ensure accuracy.
- Manifold inlet hoses should be inspected weekly for signs of cracking or kinking, replace as necessary.
- Inspect oxygen manifold output hose prior to each use for signs of cracking or kinking, replace as necessary.
- Replace inlet and output filters after 2000 hours of use (Z-7011).

9.0 PROVISION OF SPARES

9.1 SOURCE OF SPARE PARTS

Spare parts may be obtained from the manufacturer:

TRONAIR, Inc.

1 Air Cargo Pkwy East

Swanton, Ohio 43558 USA

Telephone: (419) 866-6301 or 800-426-6301

Fax: (419) 867-0634

E-mail: sales@tronair.com

Website: www.tronair.com

9.2 RECOMMENDED SPARE PARTS LISTS

Reference the following page(s) for Replacement Parts and Kits available.

10.0 IN SERVICE SUPPORT

Contact Tronair, Inc. for technical services and information. See Section 1.3 – Manufacturer.

11.0 GUARANTEES/LIMITATION OF LIABILITY

Tronair products are warranted to be free of manufacturing or material defects for a period of one year after shipment to the original customer. This is solely limited to the repair or replacement of defective components. This warranty does not cover the following items:

- a) Parts required for normal maintenance
- b) Parts covered by a component manufacturers warranty
- c) Replacement parts have a 90-day warranty from date of shipment

If you have a problem that may require service, contact Tronair immediately. Do not attempt to repair or disassemble a product without first contacting Tronair, any action may affect warranty coverage. When you contact Tronair be prepared to provide the following information:

- a) Product Model Number
- b) Product Serial Number
- c) Description of the problem

If warranty coverage is approved, either replacement parts will be sent or the product will have to be returned to Tronair for repairs. If the product is to be returned, a Return Material Authorization (RMA) number will be issued for reference purposes on any shipping documents. Failure to obtain a RMA in advance of returning an item will result in a service fee. A decision on the extent of warranty coverage on returned products is reserved pending inspection at Tronair. Any shipments to Tronair must be shipped freight prepaid. Freight costs on shipments to customers will be paid by Tronair on any warranty claims only. Any unauthorized modification of the Tronair products or use of the Tronair products in violation of cautions and warnings in any manual (including updates) or safety bulletins published or delivered by Tronair will immediately void any warranty, express or implied.

The obligations of Tronair expressly stated herein are in lieu of all other warranties or conditions expressed or implied. **Any unauthorized modification of the Tronair products or use of the Tronair products in violations of cautions and warnings in any manual (including updates) or safety bulletins published or delivered by Tronair will immediately void any warranty, express or implied and Tronair disclaims any and all liability for injury (WITHOUT LIMITATION and including DEATH), loss or damage arising from or relating to such misuse.**

12.0 APPENDICES

- APPENDIX I Smith Installation & Operator's Guide
- APPENDIX II Instrument Certification Notice
- APPENDIX III Declaration of Conformity

This page left blank intentionally.

Parts List

When ordering replacement parts/kits, please specify model, serial number and color of your unit.

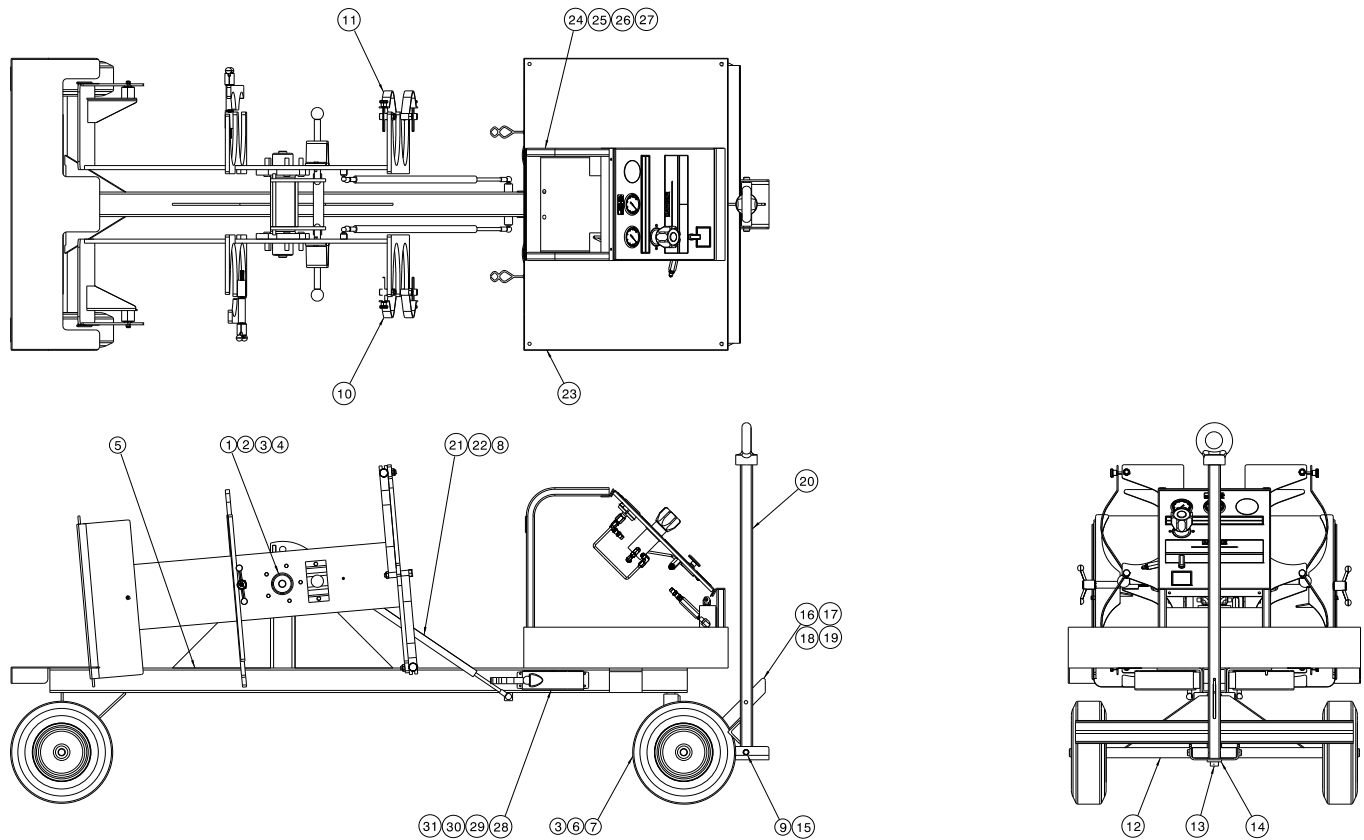

Item	Part Number	Description	Qty
1	H-3424	Hub, Bearing	2
2	G-1230-01	Nut, Axle 1 ¼	2
3	G-1283	Washer, Spindle 1"	6
4	G-1301-11	Pin, Cotter 3/16 x 1 ½	2
5	Z-8233-01	Weldment, 4-Cylinder Cart	1
6	U-1144	Assembly, Wheel w/Seal	4
7	G-1203-1120	Elastic Jamnut, 1 ¼	4
8	H-3668	Clips, Retaining	4
9	G-1301-02	Pin, Cotter 3/16 x 1 ½	2
10	Z-8186	Assembly, Left Cylinder Support	1
11	Z-8187	Assembly, Right Cylinder Support	1
12	Z-8099-01	Weldment, Front Truck	1
13	G-1301-03	Pin, Cotter ½ x 1 ½	1
14	H-2019-76	Bearing, Flange	2
15	R-2096	Pin, Towbar	1
16	J-5501	Lever	1
17	G-1503-1090N	Flatwasher, ½ Narrow, SST	2
18	G-1112-109500	Bolt, HH SST, ½ - 20 X 2 ½ Long	1
19	G-1203-1095	Elastic Jamnut, ½ - 20	1
20	Z-8173-01	Weldment, Towbar	1
21	H-3687	Dampener	2

Parts List

Item	Part Number	Description	Qty
22	H-3666	Stud, Ball 5/16 – 18	2
23	S-2625-01	Hose Tray	1
24	Z-8323	Assembly, Oxygen Panel	1
25	G-1112-105022	Bolt, HH SST, ¼ - 20 x 2 ¼ Long	2
26	G-1501-1050	ESN, SST, ¼ - 20	2

Parts List

When ordering replacement parts/kits, please specify model, serial number and color of your unit.

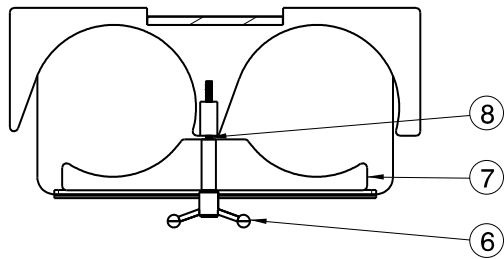

Section view A-A

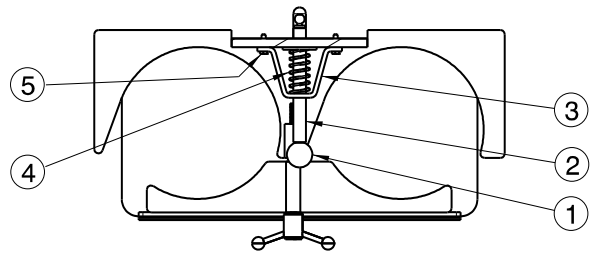

Section view B-B

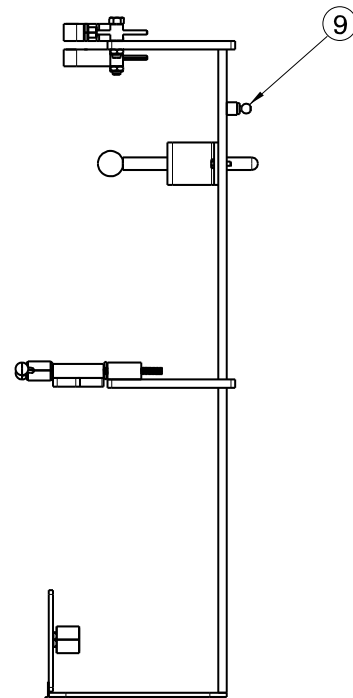
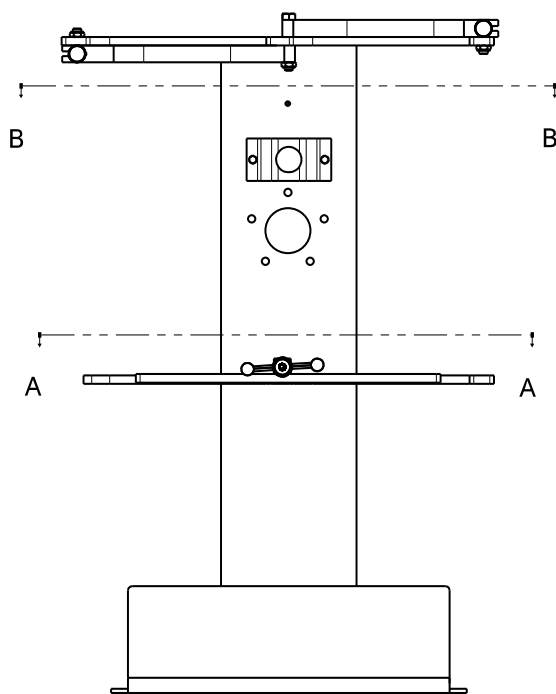
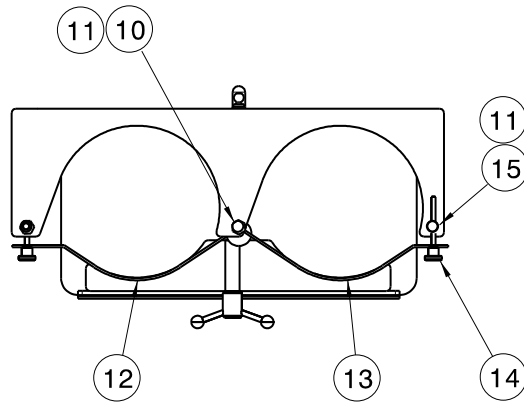

Parts List

Item	Part Number	Description	Qty
1	H-3673	Knob, Ball	1
2	Z-8171-01	Weldment, Pin	1
3	S-2626-01	Bracket, Cradle Stop	1
4	H-3674	Spring	1
5	G-1112-105010	Bolt, HH SST, ¼ - 20 x 1 Long	2
6	Z-8188-01	Machining, Clamping Handle	1
7	Z-8103-01	Weldment, Cylinder Support Handle	1
8	G-1303-13100	Pin, Roll SST, ⅛ x 1 Long	1
9	H-3666	Stud, Ball 5/16 – 18	2
10	G-1112-109030	Bolt, HH SST, ½ - 13 X 3 Long	1
11	G-1203-1090	Elastic Jamnut, ½ - 13	3
12	S-2629-01	Strap	1
13	S-2628-01	Strap	1
14	H-2677-08	Assembly, Knurled Knob, SST	2
15	R-2800	Threaded Pivot	2

Parts List

When ordering replacement parts/kits, please specify model, serial number and color of your unit.

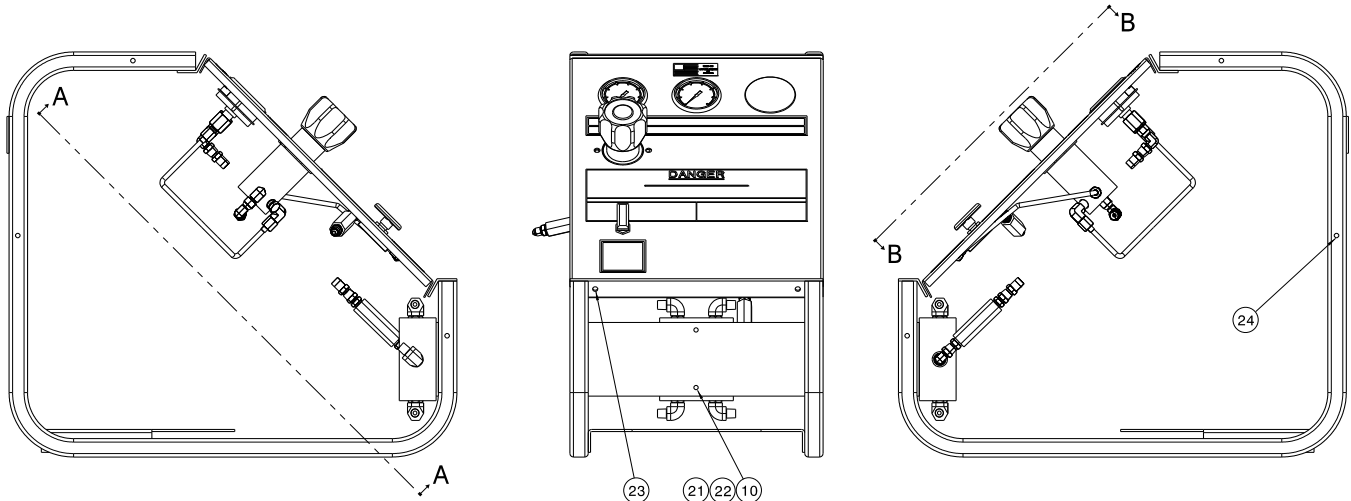
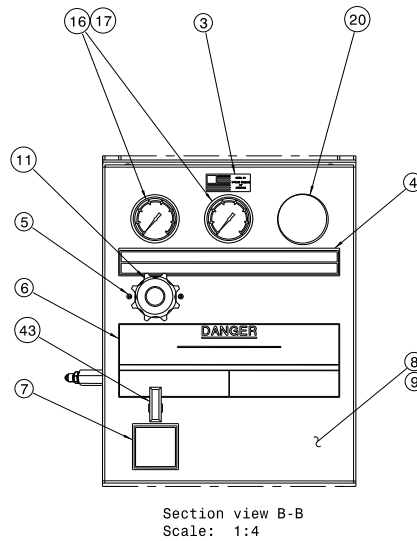
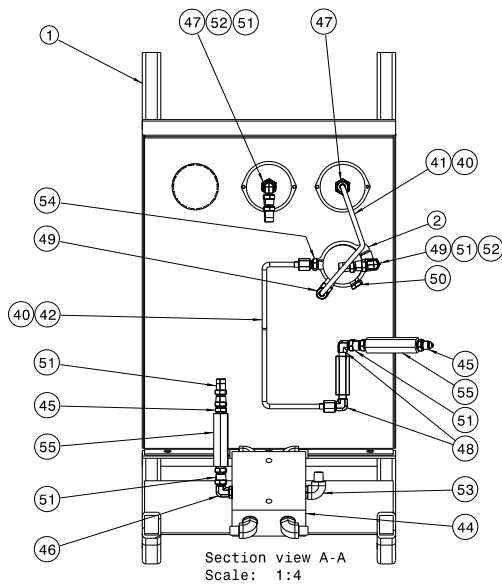

Item	Part Number	Description	Qty
1	Z-7654-01	Weldment, Frame	1
2	PC-1103	Clamp, Regulator Mounting	1
3	V-1001	Label, Made in the USA	1
4	V-2045	Label, Operator	1
5	G-1154-105204	Screw, BHCS ¼ - 20 x ½ Long	2
6	V-2044	Label, Oxygen	1
7	V-2064	Label, Output Valve	1
8	S-1908-01	Panel, Instrument	1
9	G-1439-1050-S	Nutsert, ¼ - 20	5
10	G-1100-105026	Bolt, ¼ - 20 x 2 ¾ Long	2
11	PC-1062-02	Regulator, High Pressure (Cleaned)	1
12	TF-1079-06	Pigtail, 12" Long (Cleaned) (Manifold Filter – Input Regulator)	1
13	TF-1079-01	Pigtail, 18" Long (Cleaned) (Supply Pressure Gauge – Side/Manifold)	1
14	Z-8272	Assembly, Inlet Hose (Cleaned) (Top/Bottom of Manifold)	4
15	Z-5997	Assembly, Output Hose (Cleaned) (Output Filter)	1
16	V-1556	Label, Use No Oil	2

Parts List

Item	Part Number	Description	Qty
17	HC-2289	Gauge, Pressure 5000 psi (Cleaned)	2
18	Z-8243	Cleaned Parts	1
20	H-3044-21	Plug, Finishing	1
21	G-1250-1050N	Flatwasher, ¼ narrow	4
22	G-1202-1050	ESN, ¼ - 20	4
23	G-1157-105006	Screw, PAN HD CRS REC, ¼ - 20 x ¾ Long	6
24	G-1440-1035-S	Nutsert, Open End, 10-32	6
40	HC-2285-04	Seal, Conical	4
41	TF-1249	Assembly, Hose	1
42	TF-1250	Assembly, Hose	1
43	HC-2397	Valve, Ball	1
44	J-3717	Manifold, Oxygen	1
45	N-2009-04-SS	Connector, Male	2
46	N-2755-03-SS-B	Elbow, Straight Thread	1
47	N-2098-04-SS	Connector, Female	2
48	N-2518-03-SS	Elbow, Male	2
49	N-2518-04-SS	Elbow, Male	2
50	N-2522-03-SS	Plug, Hex Head	1
51	N-2752-01-SS	Swivel, 37°	7
52	N-2753-03-SS	Elbow, Swivel Nut	4
53	N-2754-02-SS-B	Elbow, Male Pipe	5
54	N-2756-04-SS	Connector, Male	1
55	PC-1136	Filter, In-Line	2



APPENDIX I

Smith's Pressure Regulators Installation & Operation Guide



INSTALLATION & OPERATION GUIDE FOR SMITH PRESSURE REGULATORS

Important safety and operational information contained in this booklet are emphasized by a system of classification using the words: **DANGER, WARNING, CAUTION, NOTICE.**

DANGER! Danger is used to indicate the presence of a hazard which will cause severe personal injury, death or substantial property damage, if the warning is ignored.

WARNING! Warning is used to indicate the presence of a hazard which can cause severe personal injury, death or substantial property damage, if the warning is ignored.

CAUTION! Caution is used to indicate the presence of a hazard which will or can cause minor personal injury, death or substantial property damage, if the warning is ignored.

NOTICE! Notice is used to notify people of installation, operation or maintenance information which is important but not hazard related.

SPECIALTY GASES ~ SAFETY AND TECHNICAL INFORMATION

Gaseous and liquefied compressed gases may be categorized in the following classifications: flammable, oxidant, corrosive, inert or toxic. Because these products may also be gases or liquids under pressure, the hazards accompanying high pressure and low temperature may also be present. The properties of a gas place it in one or a number of categories. Certain basic rules must be followed in order to handle specialty gases safely.

- A. Know the hazards associated with the gas.
- B. Know and understand the physical and chemical properties of the gas.
- C. Observe the necessary general precautions to be taken in the use of specialty gases and the precautions specific to the gas.

In addition to the safe handling and storage procedures presented in this section, the Compressed Gas Association and the Department of Transportation provide detailed gas safety information and regulations.

A. FLAMMABLE
Flammable gases when mixed with air, oxygen or other oxidants burn or explode upon ignition, depending upon the degree of confinement. Each flammable gas has a gas-in-oxidant concentration range within the limits of which the gas may be ignited. Flammable ranges are expressed in terms of air at ambient temperature and atmospheric pressure. A change in temperature, pressure or oxidant concentration may vary the flammable range considerably. Mixtures above and below the flammable range do not ignite. As a precaution in handling flammables, care must be taken to eliminate all possible sources of

ignition through the proper design of facilities, the installation of approved electrical systems, and the restriction of smoking and use of open flames. An explosimeter should be used to determine the existence of a flammable mixture in areas of suspected leakage.

B. OXIDANT

A number of gases, although nonflammable, may initiate and support combustion. Materials that burn in air burn more vigorously or even explosively in oxygen and certain other oxidants. All possible sources of ignition must be eliminated when handling oxidants. Oxidants must not be stored with combustible materials. Oil, grease, or other readily combustible substances must not come in contact with cylinders or equipment used in oxidant service.

C. CORROSIVE

Corrosives are those products that erode and deteriorate materials with which they come in contact; such as metals, fabrics, and human tissue. Some gases, although not corrosive in their anhydrous form, become corrosive in the presence of water. Special Care must be taken when selecting the proper construction materials for equipment in which corrosives are handled. Gases that do not cause deterioration but induce inflammation of human tissue are irritants. Inflammation of the tissue may occur after immediate, prolonged or repeated contact with the irritant. Protective clothing and equipment must be used to minimize exposure to corrosive or irritating materials.

D. INERT

Gases that at ordinary temperatures and pressure do not react with other materials are classified as inert. If released in a confined area, inert gases may displace the oxygen content of the air below the level necessary to sustain life. Asphyxiation, therefore, is the hazard associated with inert products. Adequate ventilation and monitoring of the oxygen content of confined areas minimizes the possibility of asphyxiation.

E. TOXIC

Toxic materials are those substances that may chemically produce injurious or lethal effects. The degree of toxicity and the effects vary with the compound. Some gases are especially noxious because they do not provide adequate warning of their presence (by color, odor, etc.) at low levels of concentration. Also, some products that are non-toxic in themselves may react with certain chemicals or decompose at elevated temperatures to produce toxic materials. Adequate ventilation, protective clothing, and suitable breathing equipment must be used to minimize exposure.

F. HIGH PRESSURE

Specialty gases are compressed to pressures up to 6000 psig. A sudden release of pressure may cause serious damage to personnel and equipment by propelling a cylinder or whipping a line. Factors that must be considered when choosing construction materials and designing gas-handling systems are the temperature, the pressure of the gas and the possibility of pressure buildup in the system.

NOTICE!

If you have a requirement or concern not covered in the booklet, contact your equipment supplier for assistance.

WARNING!

Read and observe all warnings and instructions before installing or operating any pressure regulating equipment. Improper application and operation of equipment with high pressure media (inerts, flammables, oxidizers or toxics) can result in damage to equipment or severe personal injury.

INTRODUCTION

Prior to installing or operating any pressure regulation equipment, read and follow the information in this booklet. Improper application and operation of regulators can result in damage to equipment or severe personal injury. All possible hazards and precautionary measures are not covered in this booklet. It is recommended that prior to using gas regulation equipment, you fully understand and comply with all established safety regulations.

SECTION I PRE-INSTALLATION PROCEDURES: COMPRESSED GAS CYLINDERS

WARNING!

Serious accidents can result from improper use and handling of high pressure compressed gas cylinders. Always follow instructions and safety precautions provided by your gas supplier.

WARNING!

Read and observe all warnings and instructions before installing or operating any pressure regulating equipment. Improper application and operation of equipment with high pressure media (inerts, flammables, oxidizers or toxics) can result in damage to equipment or severe personal injury.

Refer to CGA pamphlet page 1 for all regulations which apply to the safe handling and storage of combined gas cylinders.

1. Cylinders should always be kept in the vertical position and secured from falling.
2. Never use compressed gas cylinders without an approved gas pressure reducing regulator attached to the outlet of the cylinders.
3. Do not lubricate compressed gas fittings, gauges, regulators or regulator components.
4. Do not apply sealing tape to cylinder connections.
5. Do not use cylinders with damaged threads. Return the cylinder to your supplier indicating the problem.
6. Do not use cylinder connection adaptors. Use a regulator with the proper compressed gas fitting.

SECTION II PRE-INSTALLATION PROCEDURES: REGULATORS

WARNING

Regulators must be used only with the gases and pressures for which they are designed. Consult a material safety data sheet (MSDS) for media used to determine compatibility of gases and regulator components (available from your gas supplier). Failure to do this can result in an explosion, damage to equipment or severe personal injury.

1. Check the designed pressure rating of the regulator (stamped on the regulator body) and the scale range of the pressure gauges. They must be adequate for the cylinder pressure and the operating pressure.
2. Check that the materials used in the construction of the regulator are compatible with the intended media service.
3. Check that the regulator inlet connection is compatible with the cylinder outlet valve connections.
4. Fit the operating system with a check valve purge assembly and pressure relief devices as required.
5. Do not interchange pressure regulators or other equipment with different gases unless there is knowledge of the compatibility properties of the gases.
6. Do not use regulator equipment for oxygen service that has been in other gas service.

SECTION III INSTALLATION & OPERATION TEST FOR LEAKAGE

WARNING

Check cylinder valve connections and regulator inlet connections for foreign material before connecting. Use a clean dry lint-free cloth to remove contamination. When using oxygen or other oxidizers, it is extremely important that connections are clean and maintained. Failure to do this can result in an explosion, damage to equipment or severe personal injury.

1. Inspect the cylinder valve threads for damage and be sure the cylinder valve is free of oil, grease, dirt or any foreign material.
2. Attach the regulator to the cylinder valve and secure tightly using a wrench.
3. Connect the operation system to the regulator outlet.
4. Turn the regulator adjusting screw counterclockwise until the adjusting screw turns freely (no spring load) or until the adjusting screw is against the mechanical stop. (This allows the regulator valve to close).
5. Close the regulator outlet valve if one is used.

WARNING

Do not place yourself in front of or behind the regulator when opening the cylinder. Place yourself with the cylinder between you and the regulator.

6. Slowly open the cylinder valve until the full cylinder pressure is indicated on the high pressure regulator gauge. Then, open the cylinder valve all the way. This high pressure gauge should read the cylinder pressure. The delivery gauge should read zero.
7. With the valve at the outlet of the regulator closed and the

adjusting screw tension released, leave pressure on the inlet for 5 to 10 minutes. Delivery pressure gauge should not indicate any pressure increase. A pressure increase indicates leakage past the regulator valve seat.

WARNING

If leakage occurs, do not use the regulator.

8. Turn the adjusting screw clockwise to set a normal delivery pressure. If you are unable to attain a desired pressure or the pressure continues to rise above the setpoint, the regulator should not be used.
9. If the unit functioned properly in the previous step, close the cylinder valve and note the readings of both the inlet and delivery pressure gauges. After 5 to 10 minutes, a drop in the reading of either gauge indicates a leak in the system.

NOTICE!

Use an approved oil-free leak detection fluid to locate possible leaks at the inlet, threaded parts, through the regulator diaphragm or through the outlet valve.

10. If a leak is indicated at the inlet or at a threaded port, relieve all pressures from the regulator and retighten the connections. If a leak continues or is found at the diaphragm or outlet valve, do not use the regulator.
11. If the system is determined to be leak free, turn the adjusting screw clockwise until the desired pressure setting is indicated on the delivery pressure gauge.
12. Open the outlet valve to purge the system. Adjust the regulator adjusting screw to obtain the desired pressure setting at the flow conditions.

← CAUTION →

A regulator is not intended to be used as a shut-off device. When not in use, the cylinder valve should be closed. A pressure relief device should be installed downstream of the regulator or outlet valve to protect the process equipment in the case of a rise in operating pressures.

SECTION IV SYSTEM SHUTDOWN

1. Close the cylinder valve.
2. Release all media from the regulator and/or system so that both gauges read zero. If the gas is flammable, an oxidant, corrosive, or toxic, take appropriate measures to render it innocuous by employing suitable disposable system before venting the gas to the atmosphere.
3. Turn the adjusting screw counterclockwise until all spring load is released or the adjusting screw reaches the mechanical stop.
4. Close the outlet valve.
5. Disconnect the regulator.
6. If the regulator is to remain out of service, protect the inlet and outlet fittings from dirt, contamination or mechanical damage.
7. Replace the cylinder valve cap.

SECTION V PERFORMANCE CHARACTERISTICS

The following information is intended to assist you in identifying whether or not your regulator is performing properly.

A. Proper Performance

1. The delivery pressure will drop when flow is started and/or increased.
2. The delivery pressure will rise when flow is stopped. This difference in delivery pressure between flow and no flow condition is called lockup.
3. The delivery pressure of a single stage regulator will increase as the supply/cylinder pressure decays (as the cylinder is emptied). This will not happen with a 2-stage regulator until the supply pressure drops below the first stage set pressure of 250 psig (except 250 psig delivery range regulators, which are set at 400 psig).

B. Improper Performance

1. The delivery pressure continues to rise when flow is stopped (lock-up) without a change in adjusting screw position. This indicates valve seat wear or contamination with foreign materials allowing media to leak to the delivery side. This condition is referred to as "creep". Regulators that creep leakage must not be used until repaired.
2. A significant drop in delivery pressure during normal flow conditions, indicates internal blockage. Check inlet connection filters for contamination. If condition persists, regulator must be repaired.

SECTION VI CARE AND MAINTENANCE

WARNING

Periodic inspection and maintenance of your pressure regulator is essential for continued safe and satisfactory operation. The frequency of servicing will depend on duty cycle and type of media.

Equipment should have monthly inspection and annual maintenance (removing any deposits left by media and replacing any worn or damaged parts) under normal non-corrosive use and conditions. It is also recommended that when the system has high duty cycle or is used in corrosive service, more frequent inspection and maintenance may be necessary. Regulators requiring service repair should be sent to your equipment supplier.

A. Inspection

Use the following steps for regulator inspection:

1. Inspect gauges to assure they read zero when all pressure is released from the system.
2. With adjusting screw turned counterclockwise, to release all spring tension, slowly open cylinder valve. The high pressure gauge should read cylinder pressure and the delivery gauge should read zero.
3. With valve at outlet of regulator closed and adjusting screw tension released, leave pressure on inlet for 5 to 10 minutes. The delivery pressure gauge should not indicate any pressure

increase. A pressure increase indicates leakage past the regulator valve seat.

WARNING

If leakage is indicated, the regulator must be repaired and must not be used.

4. Then, turn adjusting screw clockwise to set a nominal delivery pressure. If unable to attain desired pressure setting or if delivery pressure continues to rise above setpoint, regulator should be repaired.
5. If unit functions properly in the previous step, close cylinder valve and note the readings of both the inlet and delivery pressure gauges. After 5 to 10 minutes a drop in reading of either gauge indicates a leak in the system.

NOTICE

Use an approved oil-free leak detection fluid to locate possible leaks at the inlet, any threaded port, through the regulator diaphragm or through the outlet valve.

6. If leak is at the inlet or at a threaded port, relieve all pressure from the regulator and then tighten. If leak continues or is found at the diaphragm and outlet valve, the regulator must be repaired and must not be used.

B. Storage

1. Regulators taken out of service for extended periods should receive proper care to extend their service life.
2. Regulators used in a non-corrosive media service should be wiped clean with a clean, dry, lint-free cloth and sealed in a plastic bag for storage in a dry area at room temperature.
3. Regulators used in a corrosive media service should be well flushed with dry nitrogen and sealed in a plastic bag. Regulators used for corrosive service may continue to corrode in storage after exposed to atmospheric oxygen and moisture.

C. Repair Service

Any regulator in need of service should be returned to your equipment supplier for evaluation.



APPENDIX II

Instrument Certification Notice



Instrument Certification Notice

The gauge Certificates of Calibration supplied for the gauge(s) on this unit contain the calibration data for the actual instrument calibrated, along with the calibration date of the **STANDARD** used to perform the calibration check.

The due date for re-calibration of the instrument should be based upon the date the instrument was placed in service in your facility. Re-calibration should be done on a periodic basis as dictated by the end user's quality system or other overriding requirements.

Note that Tronair, Inc. does not supply certificates of calibration on flow meters or pyrometers unless requested at the time of placed order. These instruments are considered reference indicators only and are not critical to the test(s) being performed on the aircraft.



APPENDIX III

Declaration of Conformity



DECLARATION of CONFORMITY

The design, development and manufacture is in accordance with European Community guidelines

20-4525-0000

Relevant provisions complied with by the machinery:
2006/42/EC

Relevant standards complied with by the machinery:
EN ISO 12100-1

Identification of person empowered to sign on behalf of the Manufacturer:

A handwritten signature in black ink that reads "Patrick Funch". The signature is written in a cursive style and is positioned above a horizontal line.

Quality Assurance Representative