



SANDIA aerospace

SAE5-35 Altitude Data System

Installation Manual



This document and the information contained herein is the proprietary data of SANDIA aerospace, Inc. No part of this document may be transmitted, reproduced, or copied in any form or by any means without the prior written consent of SANDIA aerospace, Inc. Due to SANDIA aerospace's continued product and quality improvement programs, information contained in this document is subject to change without prior notice.
Copyright 2000 SANDIA aerospace, Inc., All rights reserved. Printed in USA

Record of Revisions

Revision	Date	Description	Approval
1	000908	IR	J. Fiala
2	030722	ECN3379	J. Fiala
3	20040716	ECN3429	J. Fiala
4	20080822	ECN3633	L. Harrison
5	20160203	ECN4153	L. Harrison
6	20170207	ECN4242	L. Harrison

Table Of Contents

Record of Revisions	1
Table of Contents	2
List of Illustrations	2
Section 1 - General Description	3
1.1 Introduction	3
1.1.1 Product Description	3
1.2 Technical Characteristics	3
1.2.1 Physical Characteristics	3
1.2.2 Operational Characteristics	3
1.2.3 Gillham Grey Code Output	4
1.2.4 AIM Outputs	4
1.2.5 Discrete Inputs	4
1.2.6 RS-232 Outputs	4
1.2.6.1 Standard Mode	4
1.2.6.2 Extended Mode	5
1.2.7 Certification	5
Environmental Qualification Form	6
Section 2 - Installation Considerations	7
2.1 Introduction	7
2.2 Mounting Considerations	7
2.3 Cooling	7
Section 3 - Installation Procedures	8
3.1 General	8
3.2 Equipment Required	8
3.2.1 Equipment Supplied	8
3.2.2 Equipment Not Supplied	8
3.2.3 AIM Annunciator	8
3.3 Mounting Tray Installation	8
3.4 Static Port Connection	9
3.5 Electrical Installation	9
3.6 Calibration	14
3.6.1 Equipment Required	14
3.6.2 Calibration Procedures	15
3.6.3 Placarding	16
3.7 Continued Airworthiness	16

List Of Illustrations

Figure 3-1	SAE5-35 Outline Dimensions (with tray)	9
Figure 3-2	J4/J5 Connector Wiring	11
Figure 3-3	J4/J5 Connector Hood Assembly	11
Figure 3-4	J4 Pinout	12
Figure 3-5	J5 Pinout	12
Figure 3-6	Interconnect To Popular Transponders	13
Figure 3-7	Interconnect to Garmin & UPSAT GPS and MX20	14
Figure 3-8	SAE5-35 Adjustment	16
Figure 3-9	Gillham Grey Code Chart	17-19

Section 1 General Description

1.1 INTRODUCTION

This manual describes the installation of the SANDIA aerospace SAE5-35 Altitude Data System. It is intended for use by FAA certified repair stations to install the SAE5-35 Altitude Data System and includes both the mechanical and electrical installation information for the SAE5-35. Calibration and checkout procedures are included. The installer should insure that all functions are operating according to their intended purpose in their particular installation.

1.1.1 Product Description

The SAE5-35 is a solid state -1000 to 35,000 foot altitude data system that converts pressure altitude into a digital output as set forth in the International Standard for SSR Pressure Altitude Transmission. The data output of the SAE5-35 is referenced to 29.92 inch HG (1013 Millibars). The SAE5-35 has been designed to provide altitude data to GPS and Terrain Awareness Systems in addition to Mode C Transponders. The SAE5-35 outputs Gillham Grey Code to the transponder and two independent RS232 digital outputs that can be used by GPS or other systems requiring this format. Additionally, the SAE5-35 includes SANDIA aerospace's exclusive Altitude In-flight Monitoring (AIM) feature. With the addition of an optional panel mounted switch and annunciator the AIM mode will monitor and advise the pilot if the aircraft deviates from a selected altitude.

1.2 TECHNICAL CHARACTERISTICS

1.2.1 Physical Characteristics

Width:	4.87" (5.11" with mounting tray)
Height:	1.06" (1.57" with mounting tray)
Depth:	4.74" (4.80" with mounting tray)
Weight:	0.7 lbs. (.86 lbs. with mounting tray)

1.2.2 Operational Characteristics

Operating Temp.	-20o C to + 55o C
Altitude:	35,000 feet
Voltage:	11 - 32 Vdc
Current	1.0 amps maximum with heater on <100 mA quiescent
Accuracy:	+/- 50 feet Typical
Resolution:	Grey Code 100' RS232 10'
Burst Pressure	90 in Hg
Maximum Rate of Altitude Change:	12,000 Feet/Minute

1.2.3 Gillham Grey Code Outputs

- a. 10 Bits available: D4, A4, A2, A1, B4, B2, B1, C4, C2, C1
- b. Bit On Impedance: Less than 5 ohms
- c. Bit Off Leakage: Less than 10uA
- d. Maximum Current per bit: 20 mA
- e. Minimum working current: 10 uA
- f. Maximum voltage per bit: 50V
- g. Minimum working voltage: 5V
- h. Bit update rate: Less than 250 mS
- i. Minimum strobe switching bandwidth: Greater than 10kHz

1.2.4 AIM Outputs

Maximum Lamp Current: 80 mA
Maximum off Voltage: 50V

1.2.5 Discrete Inputs

AIM SET, Strobe and RS232 Mode Select Inputs
Asserted: < 0.4 Vdc
Not Asserted: > 1.7 Vdc
Pull-up current: 150 uA

1.2.6 RS-232 Outputs

There are two modes of operation for the RS232 outputs. The Data Mode pin, J5 pin 4 selects the data formats.

1.2.6.1 Standard Mode

When the Mode pin (J5 pin 4) is open:

- a. Baud: 9600
- b. Data bits: 8
- c. Stop bit: 1
- d. Parity: None
- e. Output rate: 1 +/- .2 seconds
- f. Message length: 11 bytes
- g. Altitude resolution: 10 foot
- h. Works with Garmin and Trimble GPS

1.2.6.2 Extended Mode

When the Mode pin (J5 pin 4) is grounded:

- a. Baud: 1200
- b. Data bits: 8
- c. Stop bit: 1
- d. Parity: None
- e. Output rate: 1 +/- .2 seconds
- f. Message length: 17 bytes
- g. Altitude resolution: 10 foot
- h. Temperature resolution: 1 degree C
- i. For use with UPSAT MX20 and GPS receivers

1.2.7 Certification

TSO:	C88a
ETSO:	C88a
Software:	DO-178B Level C
Environmental:	DO-160D(C1)CAA[(SM)(UF)]XXXXXXXXZBBBBTBXXXX

Environmental Qualification Form for the SAE5-35 Altitude Data System

NOMENCLATURE: SAE5-35, Altitude Data System

TYPE/MODEL/PART NO: SAE5 – 35 / 305154-00

TSO NUMBER: C88a

MANUFACTURER’S SPECIFICATION AN/OR OTHER APPLICABLE SPECIFICATION:

SAE5-35 INSTALLATION MANUAL P/N 305186-00

QUALIFICATION TEST PLAN, SAE5-35 ALTITUDE ENCODER. P/N AENC0051

MANUFACTURER: SANDIA AEROSPACE

ADDRESS: 5445 EDITH BLVD. NE, SUITE I ALBUQUERQUE, NM 87107

REVISION & CHANGE NUMBER OF DO-160: REV D, DATED JULY 27 1997

DATE OF TEST: July 2000

CONDITIONS	SECTION	DESCRIPTION OF TESTS CONDUCTED
Temperature and Altitude	4.0	Equipment Tested to Category C1
Low Temperature	4.5.1	Tested to -20°C Operating Low Temp
High Temperature	4.5.2 & 4.5.3	Tested to +55°C Operating High Temp
In-Flight Loss of Cooling	4.5.4	Test not Applicable
Altitude	4.6.1	35,000 feet
Decompression	4.6.2	Test not Applicable
Overpressure	4.6.3	Test not Applicable
Temperature Variation	5.0	Tested to Category C
Humidity	6.0	Tested to Category A
Operational Shock and Crash Safety	7.0	Tested to Category A
Vibration	8.0	Tested to Category S, Aircraft Zone 2 using vibration curve M. Tested to Category U, Helicopter Zone 2 using vibration curves F and F1.
Explosion	9.0	Equipment identified as Category X, no test performed
Waterproofness	10.0	Equipment identified as Category X, no test performed
Fluids Susceptibility	11.0	Equipment identified as Category X, no test performed
Sand and Dust	12.0	Equipment identified as Category X, no test performed
Fungus	13.0	Equipment identified as Category X, no test performed
Salt Spray	14.0	Equipment identified as Category X, no test performed
Magnetic Effect	15.0	Equipment is category Z
Power Input	16.0	Tested to Category B
Voltage Spike	17.0	Tested to Category B
Audio Frequency Susceptibility	18.0	Tested to Category B
Induced Signal Susceptibility	19.0	Tested to Category B
Radio Frequency Susceptibility	20.0	Tested to Category T
Radio Frequency Emission	21.0	Tested to Category B
Lightning Induced Transient Susceptibility	22.0	Equipment identified as Category X, no test performed
Lightning Direct Effects	23.0	Equipment identified as Category X, no test performed
Icing	24.0	Equipment identified as Category X, no test performed
Electrostatic Discharge	25.0	Equipment identified as Category X, no test performed

Section 2 Installation Considerations

2.1 INTRODUCTION

The SAE5-35 Altitude Data System simplifies installations that include GPS, Terrain Awareness Systems and other avionics that require RS232 altitude input information. The SAE5-35 provides standard Gillham Grey Code output on its 15 pin connector. Grey code is required for interface to Mode C ATRCBS and Mode S transponders. Two independent RS232 outputs are provided on the nine pin connector. The SAE5-35 also incorporates SANDIA aerospace's exclusive Altitude In-flight Monitoring (AIM) feature that advises pilots if they deviate from their selected altitude by more than one hundred feet. The AIM feature can be installed with an installer supplied switch and annunciator assembly(s). The main 15 pin connector follows the standard encoder interconnect used by many manufacturers. By following this convention, upgrading to the SAE5-35 is made easier. If another manufacturers encoder is being replaced, it is important to check the wiring information before plugging the existing connector into the SAE5-35. Both the Grey Code output and each of the RS232 outputs have separate drivers. This ensures that a load on one line does not load the other. Additionally, the RS232 output is available even if the enable line on the Grey Code has not been enabled by the transponder.

The SAE5-35 does not require warm up unless the outside temperature is below 20 degrees C. When warm up time is required, the internal heater is capable of warming the SAE5-35 from -20 degrees C to operating temperature in less than two minutes.

2.2 MOUNTING CONSIDERATIONS

The SAE5-35 can be mounted in any axis and either inside or outside the pressure vessel. Mounting should allow for as short a pressure line as possible from the encoder to the altimeter. Be sure to allow an ample service loop on the cable to allow for calibration of the SAE5-35.

CAUTION: DO NOT mount the SAE5-35 in the direct airstream or near either the hot or cold air ducts.

CAUTION: When mounting in critical areas that could cause a potential flight hazard should the SAE 5-35 comes loose from the mounting tray, the optional mounting tray and Knurled Nut with accommodation for safety wire must be used. The Installation kit number for this tray and nut is 305216-02.

2.3 COOLING

The SAE5-35 does not require external cooling.

Section 3 Installation Procedures

3.1 GENERAL

The SAE5-35 is supplied with a mounting tray and solder type mating connectors. It is important that proper solder techniques be observed in attaching wires to the mating connectors. Failure to do so could result in a failure in the connection and cause intermittent or non operation of the SAE5-35.

3.2 EQUIPMENT REQUIRED

3.2.1 Supplied

SAE5-35 System 705154-XX*

*705154-00 is supplied with the standard mechanical installation kit

*705154-02 is supplied with the safety wireable mechanical installation kit

Includes:	SAE5-35 Encoder	305154-00
	SAE5-35 Installation Manual	305186-00
	SAE5-35 Installation Kit - Electrical	305216-10
	15 Pin Mating Connector	305215
	15 Pin Connector Hood	305208
	9 Pin Mating Connector	305214
	9 Pin Connector Hood	305207
	SAE5-35 Installation Kit - Mechanical	305216-00
	Mounting Tray	305145
	Knurled Holdown Nut	305189

3.2.2 Required but not supplied

Number 6-32 mounting screws

Static port fitting

3.2.3 Optional Equipment

3.2.3.1 AIM Annunciator, Installer supplied

3.2.3.2 Optional Mounting Tray

An Optional mounting tray and hold down nut with provisions for safety wire is available.

Kit, Mechanical Installation, Safety Wire 305216-02

Tray, Close Mounting 306352

Nut, Knurled, Safety 306353

Use System P/N 705154-02 to order SAE 5-35 with this option.

3.3 MOUNTING TRAY INSTALLATION

The mounting tray is mounted to the airframe using either three or four number 6-32 screws. The mounting hole pattern for the SAE5-35 mounting tray contains five holes. For new installations, it is recommended that the four corner holes be used to mount the SAE5-35 tray. The fifth hole has been added to facilitate upgrades from other manufactures encoders. Refer to the SAE5-35 tray dimensions in Figure 3-1 to determine if the hole pattern of the removed system match the hole pattern of the SAE5-35 mounting tray.

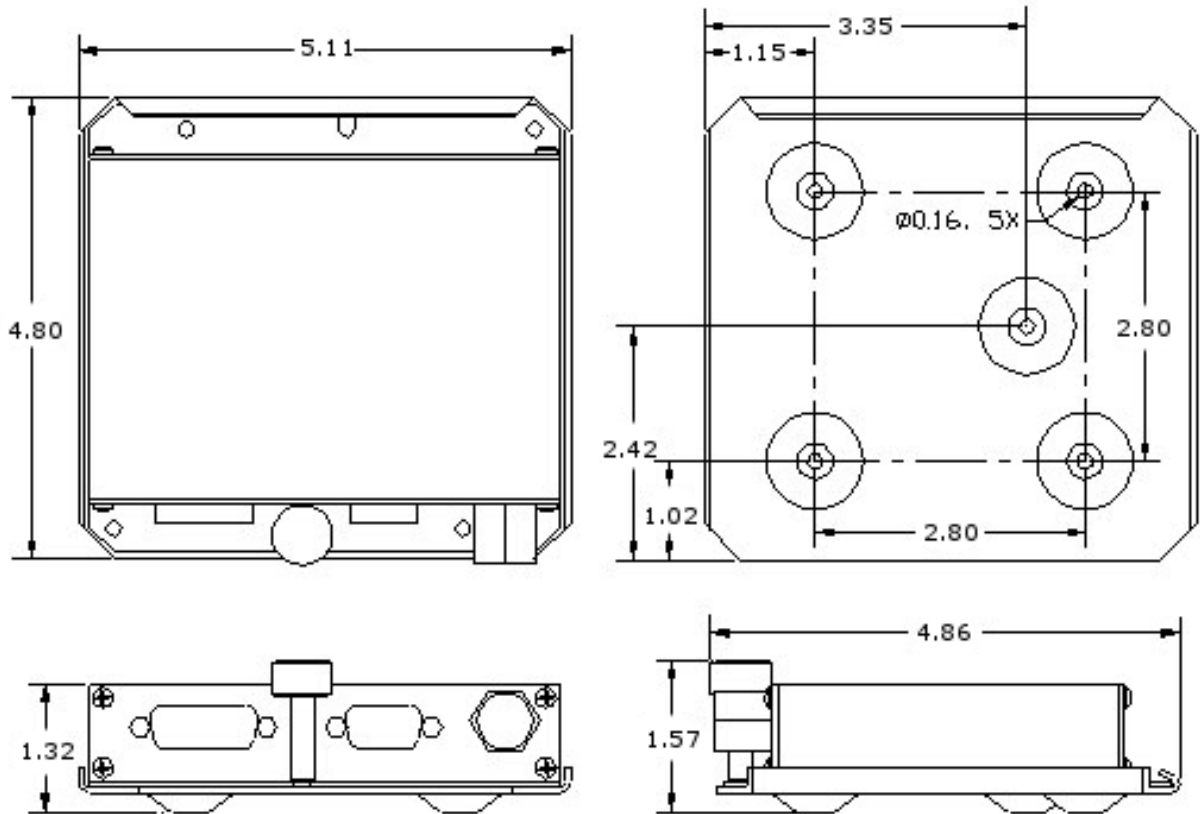

Figure 3-1
SAE5-35 Outline Dimensions (with tray)

3.4 STATIC PORT CONNECTION

A standard 1/8 - 27 NPT brass fitting is provided on the front plate of the encoder for attaching to the aircraft static air system. An adapter may be used to convert this to match the aircraft static plumbing. When attaching the mating fitting, make sure that it is secure and free from leaks that can induce errors in the static system. In installations where an existing encoder is being replaced, the existing tubing and fittings should be examined for any damage or deterioration and replaced if necessary. To reduce the likelihood of the brass fitting rotating while installing the static lines, a “D” shaped hole is used to mount the brass fitting into the front panel. Upon completion of installation of the SAE5-35, a Case Leak test is to be performed per FAR Part 43 Appendix E

NOTE: Since significant force can be applied to the encoder during static fitting installation, dual wrench techniques are always recommended to avoid damage to the encoder.

3.5 ELECTRICAL INSTALLATION

The SAE5-35 is designed to operate from 11-32Vdc without any special wiring considerations. Power can be supplied from the transponder’s switched A+ output, the transponder circuit breaker or from the aircraft buss. If supplied from the aircraft buss, the line must be protected with a 2 amp fuse or circuit breaker. SAE document

AS8003 Minimum Performance Standard for Automatic Pressure Altitude Reporting Code Generating Equipment states that “a means shall be incorporated in the equipment to indicate the loss of electrical power or the effect thereof, unless the electrical power to operate the code generating equipment is supplied by an ATC Transponder which also supplies an indication of this power loss.” This is typically accomplished by using the switched A+ output from the transponder or by connecting the SAE5-35 power input to the transponder circuit breaker. Alternatively, the two power pins, 8 and 14, are internally connected in the SAE5-35. Only one of these connections is necessary to supply power to the unit. The unused connection can be used to drive a panel-mounted indicator if desired.

All transponder functions including the Grey code output are on the 15 pin connector J4. The RS232 digital outputs for GPS and other avionics requiring this format as well as the AIM function are on the 9 pin connector J5. The Grey code output on the transponder is disabled whenever Mode C on the transponder is not selected.

Note: The RS232 serial data output is always present whenever there is power to the SAE5-35 and the warm up time is completed, even when the Strobe/Enable line is not grounded.

Note: If power is supplied from the transponder, the RS232 and AIM functions will be inoperative when the transponder is turned off or removed from the aircraft.

Grounding the Strobe/Enable line on J4 pin 6 will enable the transponder Grey code data. There are three methods used to do this.

1. Permanently grounding this line.
2. The transponder provides a switched ground enable signal.
3. The transponder provides a strobe-ground enable signal.

The SAE5-35 is compatible with all three systems, refer to the appropriate transponder installation manual for detail. Interconnect information for the most popular transponders can be found in Figure 3-6. For other makes of transponders, refer to the manufacturers installation manual.

Note: If the transponder being interfaced has a strobe output, the AIM function will not operate properly and should not be connected.

While several manufacturers use RS232 digital altitude data, their formats and baud rates may vary. The SAE5-35 can accommodate most data formats by either grounding or leaving pin 4 on J5 open. If pin 4 is left open, the output baud rate is 9600. If pin 4 is grounded, the output baud rate is 1200. The RS232 interconnect information can be found in Figure 3-7.

Interconnect information for the most popular transponders can be found in Figures 3-6. The RS232 interconnect information can be found in Figure 3-7.

The SAE5-35 uses Sub-D solder cup connectors with screw lock assemblies. Proper wire attachment and assembly of the screw locks and connector hood are shown in Figure 3-2 and 3-3. It is recommended that each wire and solder cup be covered with a piece of shrink tubing or other insulator.

The SAE5-35 uses Sub-D solder cup connectors with screw lock assemblies. Proper wire attachment and assembly of the screw locks and connector hood are shown in Figure 3-2 and 3-3. It is recommended that each wire and solder cup be covered with a piece of shrink tubing or other insulator.

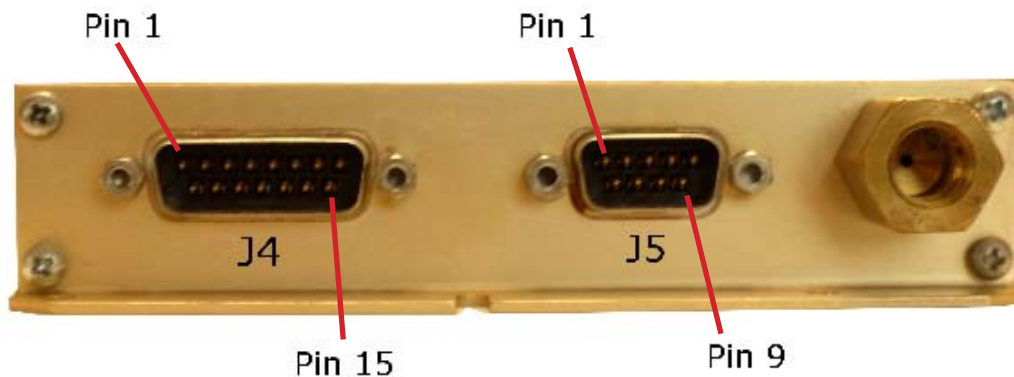

Figure 3-2
J4/J5 Connector Pins



Figure 3-3
J4/J5 Connector Hood Assembly

J4

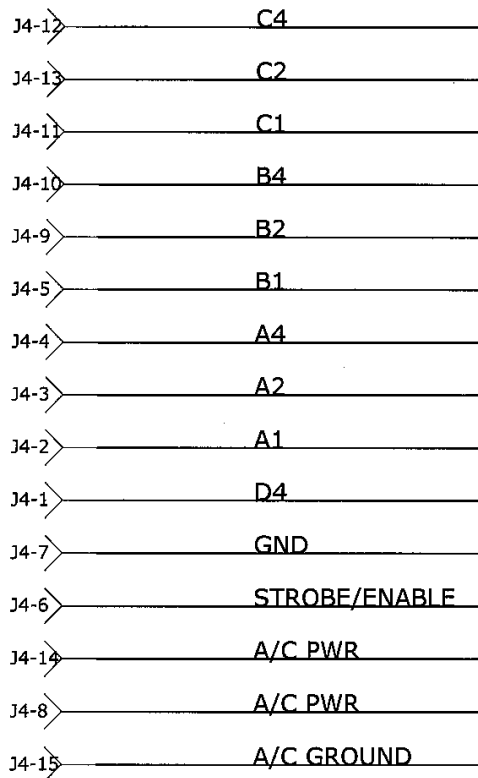

Figure 3-4
J4 Pinout

J4 Notes:

1. J4 is 15 Pin receptacle
2. Pin 6 may be strobed or permanently grounded.
Pin 6 must be grounded for AIM function to be operational.
3. Power and ground wires (pins 8, 14 & 15) are 20 AWG. All other wires are 22AWG unless otherwise noted.
4. Pin 8 and 14 are internally connected in the SAE5-35. Only one line is necessary to supply power to the unit. The unused power pin may be used as a power loss indicator if desired.
5. The Garmin 430/530 must be set to Icarus RS232 format.

J5

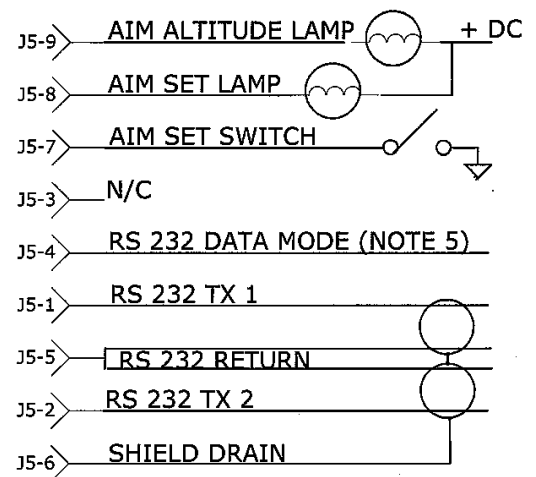

Figure 3-5
J5 Pinout

J5 Notes:

1. J5 is 9 Pin receptacle
2. Maximum lamp current 80mA
3. All wires are 22AWG unless otherwise noted.
4. AIM switch is a momentary contact
5. Ground pin 4 for 1200 baud
Leave pin 4 open for 9600 baud (see Paragraph 1.2.6.1 & 1.2.6.2 for details).
6. If the AIM function uses annunciator lamps provided by the installer, they should be appropriately labeled. The lamp connected to pin 9 should be labeled 'ALT' and the lamp connected to pin 8 should be labeled 'SET'.

SAE5-35 J4	Function	Bendix TPR2060	Bendix TR641A/B	Cessna RT359T, RT459A, RT859A	Garmin GTX22X Series	Garmin GTX330, GTX33 (J3301)	Honeywell KT70/71 (Connector JKT701)	Honeywell KT76A/78A	Honeywell KXP	Narco AT50/A, AT150	Narco AT5, AT6/A	UPSAT SL70	Wilcox 1014A
1	D4	No Connection	N	10	18	11	8	No Connection	V	No Connection	No Connection	35	C
2	A1	4	A	14	3	2	M	M	G	7	2	13	k
3	A2	6	B	13	5	4	K	K	H	6	4	31	c
4	A4	8	C	15	6	5	J	J	J	8	8	12	W
5	B1	9	D	19	9	7	E	E	K	12	9	33	T
6	Strobe/Enable	Aircraft Ground	Aircraft Ground	11	Aircraft Ground	Aircraft Ground	Aircraft Ground	Aircraft Ground	Aircraft Ground	5	12	Aircraft Ground	Aircraft Ground
7	Ground	Aircraft Ground	Aircraft Ground	Aircraft Ground	Aircraft Ground	Aircraft Ground	Aircraft Ground	Aircraft Ground	Aircraft Ground	Aircraft Ground	Aircraft Ground	Aircraft Ground	Aircraft Ground
8	Aircraft Power	Note 1	Note 1	9 or per Note 1	Note 1	Note 1	Note 1	Note 1	Note 1	18 or per Note 1	13 or per Note 1	Note 1	Note 1
9	B2	10	E	17	11	9	C	C	L	10	10	14	L
10	B4	11	F	16	12	10	B	B	M	9	11	32	D
11	C1	3	H	21	10	8	D	D	P	14	1	16	P
12	C4	7	K	20	7	6	H	H	S	13	5	15	Z
13	C2	5	J	18	4	3	L	L	R	11	3	34	f
14	Aircraft Power	Note 1	Note 1	Note 1	Note 1	Note 1	Note 1	Note 1	Note 1	Note 1	Note 1	Note 1	Note 1
15	Aircraft Ground	Aircraft Ground	Aircraft Ground	Aircraft Ground	Aircraft Ground	Aircraft Ground	Aircraft Ground	Aircraft Ground	Aircraft Ground	Aircraft Ground	Aircraft Ground	Aircraft Ground	Aircraft Ground

Figure 3-6
Interconnect for popular transponders

Notes:

1. The two power pins, 8 and 14, are internally connected in the SAE5-35. Only one of these connections is necessary to supply power to the unit. The unused connection can be used to drive a panel-mounted indicator if desired.

SAE5-35 J5	Function	Garmin 430 P4001	Garmin 530 P5001	UPSAT GX60/65 37 Pin Connector	UPSAT MX20 P2
1	RS232 TX1	57	57	4 or 21	21
2	RS232 TX2	Note 1	Note 1	Note 1	Note 1
3	N/C	No Connection	No Connection	No Connection	No Connection
4	RS232 Mode Select	No Connection	No Connection	Aircraft Ground	Aircraft Ground
5	RS232 Return	77 or 78	77 or 78	25	3
6	RS232 Shield	Open Note 3	Open Note 3	Open Note 3	Open Note 3
7	AIM 'SET' Switch	Note 4	Note 4	Note 4	Note 4
8	AIM 'SET' Lamp	Note 4	Note 4	Note 4	Note 4
9	AIM 'ALT' Lamp	Note 4	Note 4	Note 4	Note 4

Figure 3-7
J5 interconnect With Garmin and UPSAT Systems

Notes:

1. The SAE5-35 has two independent RS232 outputs. RS232 TX2 can be connected to a second system in the same manner as RS232 TX1
2. The RS232 wires are 22 AWG twisted pair.
3. Shield grounds are ground at the SAE5-35 and open at the unit being interfaced.
4. See Figure 3-5 for AIM function interconnect wiring.

3.6 CALIBRATION

The SAE5-35 is calibrated at the factory to a pressure datum traceable to the National Bureau of Standards. However, when the encoder is installed in the aircraft it must be recalibrated to correspondence to the primary flight altimeter, refer to FAR 91.217 and FAR 91.413 for details. This calibration ensures that the altitude code generated from the SAE5-35 is within 125 feet of the altitude displayed to the pilot.

3.6.1 Equipment Required

1. A calibrated pitot-static test set capable of pumping the system from -1000 feet up the maximum test altitude.
2. A calibrated transponder ramp tester capable of displaying the encoder altitude information.

3.6.2 Calibration Procedures

Note: The Primary Flight Altimeter must be calibrated per part 43 section E. Verify compliance with AC-43.13 as applicable.

1. Connect the pitot-static test set to the aircraft static system. The SAE5-35 must be connected to the aircraft static line near the flight altimeter and the two altitude adjustments buttons must be accessible. Apply power to the altitude encoder and the ATC transponder and allow the encoder to stabilize. Set primary flight altimeter to 29.92 inches of mercury.
2. Apply vacuum from the pitot-static test set to obtain an altimeter reading of 34,800 feet (or 100 feet below the maximum test altitude specified in Part 43, appendix F.)
3. Slowly increase altitude and note the flight altimeter at the encoder transition point. If the transition point is not 34,850 +/- 30 feet (or between -80 feet and -20 feet below the maximum test altitude), press the increase button (behind slot A) or decrease button (behind slot B) until the encoder transition point is within tolerance.
4. Increase altitude to obtain an altimeter reading of 35,000 feet (or 100 feet above the maximum altitude specified in Part 43, appendix F.)
5. Slowly decrease altitude and read the flight altimeter at the encoder transition point. Verify the transition point is 34,950 +/- 30 feet (or between 20 feet and 80 feet above the maximum test altitude.) If necessary, press the increase button (behind slot A) or decrease button (behind slot B) until the encoder transition point is within tolerance.
6. Apply pressure from the pitot-static test set to obtain an altimeter reading of -800feet
7. Slowly decrease altitude and read the flight altimeter at the encoder -800 foot to -900-transition point. If the transition point is higher than -880 feet, hold the increase altitude button (behind slot A) while pressing and releasing the decrease altitude button (behind slot B) until the transition point is -850 +/- 30feet. If the transition point is lower than -820 feet, hold the decrease altitude button (behind slot B) while pressing and releasing the increase altitude button (behind slot A) until the transition point is -850 +/- 30feet.
8. Apply pressure from the pitot-static test set to obtain an altimeter reading of -1000feet
9. Slowly increase altitude and read the flight altimeter at the encoder -1000 foot to -900-transition point. If the transition point is higher than -920 feet, hold the increase altitude button (behind slot A) while pressing and releasing the decrease altitude button (behind slot B) until the transition point is -950 +/- 30 feet. If the transition point is lower than -980 feet, hold the decrease altitude button (behind slot B) while pressing and releasing the increase altitude button (behind slot A) until the transition point is -950 +/- 30 feet.

10. Repeat steps 2 through 10 until the transition points and the flight altimeter are within tolerance for both low and high altitudes. Verify several test points throughout the range to assure correspondence between the SAE5-35 and the flight altimeter.

OOPS !
The SAE5-35 can be reset to factory settings by applying power to the unit while simultaneously pressing both adjustments A & B

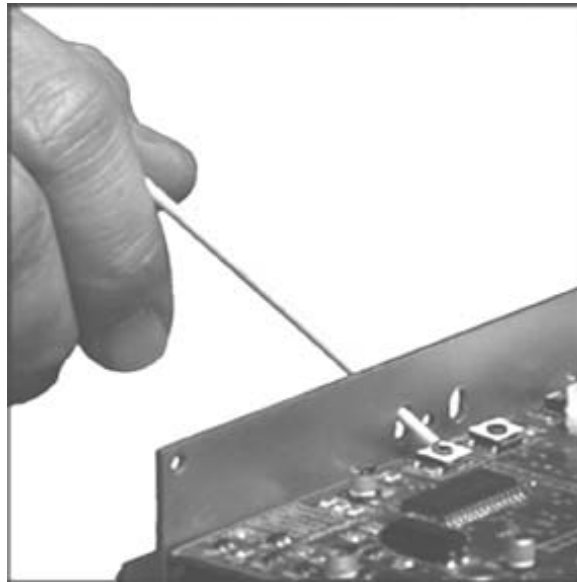

Figure 3-8
SAE 5-35 Adjustment

3.6.3 Placarding

We recommend that the altimeter used for flight reference and the SAE5-35 be placarded with the following information:

Replacement or re-calibration of the altimeter used for flight reference requires re-calibration of SAE5-35 Altitude Encoder. Altitude encoded to feet.

3.7 Continued Airworthiness

The SAE5-35 requires calibration every 24 months per FAR 91.411. All other maintenance of the SAE5-35 is on condition only.

Altitude	D4	A1	A2	A4	B1	B2	B4	C1	C2	C4	Altitude	D4	A1	A2	A4	B1	B2	B4	C1	C2	C4
-1000	0	0	0	0	0	0	0	0	1	0	4800	0	0	0	1	0	1	0	0	0	1
-900	0	0	0	0	0	0	0	0	1	1	0	0	0	1	0	1	0	0	0	1	1
-800	0	0	0	0	0	0	0	0	1	0	5000	0	0	0	1	0	1	0	0	1	0
-700	0	0	0	0	0	0	1	1	0	0	5100	0	0	0	1	0	1	0	1	1	0
-600	0	0	0	0	0	0	1	1	1	0	5200	0	0	0	1	0	1	0	1	0	0
-500	0	0	0	0	0	0	1	0	1	0	5300	0	0	0	1	0	1	1	1	0	0
-400	0	0	0	0	0	0	1	0	1	1	5400	0	0	0	1	0	1	1	1	1	1
-300	0	0	0	0	0	0	1	0	0	1	5500	0	0	0	1	0	1	1	0	1	0
-200	0	0	0	0	0	1	1	0	0	1	5600	0	0	0	1	0	1	1	0	1	1
-100	0	0	0	0	0	1	1	0	1	1	5700	0	0	0	1	0	1	1	0	0	1
0	0	0	0	0	0	1	1	0	1	0	5800	0	0	0	1	0	0	1	0	0	1
100	0	0	0	0	0	1	1	1	1	0	5900	0	0	0	1	0	0	1	0	1	1
200	0	0	0	0	0	1	1	1	0	0	6000	0	0	0	1	0	0	1	0	1	0
300	0	0	0	0	0	1	0	1	0	0	6100	0	0	0	1	0	0	1	1	1	0
400	0	0	0	0	0	1	0	1	1	0	6200	0	0	0	1	0	0	1	1	0	0
500	0	0	0	0	0	1	0	0	1	0	6300	0	0	0	1	0	0	0	1	0	0
600	0	0	0	0	0	1	0	0	1	1	6400	0	0	0	1	0	0	0	1	1	0
700	0	0	0	0	0	1	0	0	0	1	6500	0	0	0	1	0	0	0	0	1	0
800	0	0	0	0	1	1	0	0	0	1	6600	0	0	0	1	0	0	0	0	1	1
900	0	0	0	0	1	1	0	0	1	1	6700	0	0	0	1	0	0	0	0	0	1
1000	0	0	0	0	1	1	0	0	1	0	6800	0	0	1	1	0	0	0	0	0	1
1100	0	0	0	0	1	1	0	1	1	0	6900	0	0	1	1	0	0	0	0	1	1
1200	0	0	0	0	1	1	0	1	0	0	7000	0	0	1	1	0	0	0	0	1	0
1300	0	0	0	0	1	1	1	1	0	0	7100	0	0	1	1	0	0	0	1	1	0
1400	0	0	0	0	1	1	1	1	1	0	7200	0	0	1	1	0	0	0	1	0	0
1500	0	0	0	0	1	1	1	0	1	0	7300	0	0	1	1	0	0	1	1	0	0
1600	0	0	0	0	1	1	1	0	1	1	7400	0	0	1	1	0	0	1	1	1	0
1700	0	0	0	0	1	1	1	0	0	1	7500	0	0	1	1	0	0	1	0	1	0
1800	0	0	0	0	1	0	1	0	0	1	7600	0	0	1	1	0	0	1	0	1	1
1900	0	0	0	0	1	0	1	0	1	1	7700	0	0	1	1	0	0	1	0	0	1
2000	0	0	0	0	1	0	1	0	1	0	7800	0	0	1	1	0	1	1	0	0	1
2100	0	0	0	0	1	0	1	1	1	0	7900	0	0	1	1	0	1	1	0	1	1
2200	0	0	0	0	1	0	1	1	0	0	8000	0	0	1	1	0	1	1	0	1	0
2300	0	0	0	0	1	0	0	1	0	0	8100	0	0	1	1	0	1	1	1	1	0
2400	0	0	0	0	1	0	0	1	1	0	8200	0	0	1	1	0	1	1	1	0	0
2500	0	0	0	0	1	0	0	0	1	0	8300	0	0	1	1	0	1	0	1	0	0
2600	0	0	0	0	1	0	0	0	1	1	8400	0	0	1	1	0	1	0	1	1	0
2700	0	0	0	0	1	0	0	0	0	1	8500	0	0	1	1	0	1	0	0	1	0
2800	0	0	0	1	1	0	0	0	0	1	8600	0	0	1	1	0	1	0	0	1	1
2900	0	0	0	1	1	0	0	0	1	1	8700	0	0	1	1	0	1	0	0	0	1
3000	0	0	0	1	1	0	0	0	1	0	8800	0	0	1	1	1	1	0	0	0	1
3100	0	0	0	1	1	0	0	1	1	0	8900	0	0	1	1	1	1	0	0	1	1
3200	0	0	0	1	1	0	0	1	0	0	9000	0	0	1	1	1	1	0	0	1	0
3300	0	0	0	1	1	0	1	1	0	0	9100	0	0	1	1	1	1	0	1	1	0
3400	0	0	0	1	1	0	1	1	1	0	9200	0	0	1	1	1	1	0	1	0	0
3500	0	0	0	1	1	0	1	0	1	0	9300	0	0	1	1	1	1	1	1	0	0
3600	0	0	0	1	1	0	1	0	1	1	9400	0	0	1	1	1	1	1	1	1	0
3700	0	0	0	1	1	0	1	0	0	1	9500	0	0	1	1	1	1	1	0	1	0
3800	0	0	0	1	1	1	1	0	0	1	9600	0	0	1	1	1	1	1	0	1	1
3900	0	0	0	1	1	1	1	0	1	1	9700	0	0	1	1	1	1	1	0	0	1
4000	0	0	0	1	1	1	1	0	1	0	9800	0	0	1	1	1	0	1	0	0	1
4100	0	0	0	1	1	1	1	1	1	0	9900	0	0	1	1	1	0	1	0	1	1
4200	0	0	0	1	1	1	1	1	0	0	10000	0	0	1	1	1	0	1	0	1	0
4300	0	0	0	1	1	1	0	1	0	0	10100	0	0	1	1	1	0	1	1	1	0
4400	0	0	0	1	1	1	0	1	1	0	10200	0	0	1	1	1	0	1	1	0	0
4500	0	0	0	1	1	1	0	0	1	0	10300	0	0	1	1	1	0	0	1	0	0
4600	0	0	0	1	1	1	0	0	1	1	10400	0	0	1	1	1	0	0	1	1	0
4700	0	0	0	1	1	1	0	0	0	1	10500	0	0	1	1	1	0	0	0	1	0

Figure 3-9
Gillham Grey Code Chart

Altitude	D4	A1	A2	A4	B1	B2	B4	C1	C2	C4
10600	0	0	1	1	1	0	0	0	1	1
10700	0	0	1	1	1	0	0	0	0	1
10800	0	0	1	0	1	0	0	0	0	1
10900	0	0	1	0	1	0	0	0	1	1
11000	0	0	1	0	1	0	0	0	1	0
11100	0	0	1	0	1	0	0	1	1	0
11200	0	0	1	0	1	0	0	1	0	0
11300	0	0	1	0	1	0	1	1	0	0
11400	0	0	1	0	1	0	1	1	1	0
11500	0	0	1	0	1	0	1	0	1	0
11600	0	0	1	0	1	0	1	0	1	1
11700	0	0	1	0	1	0	1	0	0	1
11800	0	0	1	0	1	1	1	0	0	1
11900	0	0	1	0	1	1	1	0	1	1
12000	0	0	1	0	1	1	1	0	1	0
12100	0	0	1	0	1	1	1	1	1	0
12200	0	0	1	0	1	1	1	1	0	0
12300	0	0	1	0	1	1	0	1	0	0
12400	0	0	1	0	1	1	0	1	1	0
12500	0	0	1	0	1	1	0	0	1	0
12600	0	0	1	0	1	1	0	0	1	1
12700	0	0	1	0	1	1	0	0	0	1
12800	0	0	1	0	0	1	0	0	0	1
12900	0	0	1	0	0	1	0	0	1	1
13000	0	0	1	0	0	1	0	0	1	0
13100	0	0	1	0	0	1	0	1	1	0
13200	0	0	1	0	0	1	0	1	0	0
13300	0	0	1	0	0	1	1	1	0	0
13400	0	0	1	0	0	1	1	1	1	0
13500	0	0	1	0	0	1	1	0	1	0
13600	0	0	1	0	0	1	1	0	1	1
13700	0	0	1	0	0	1	1	0	0	1
13800	0	0	1	0	0	0	1	0	0	1
13900	0	0	1	0	0	0	1	0	1	1
14000	0	0	1	0	0	0	1	0	1	0
14100	0	0	1	0	0	0	1	1	1	0
14200	0	0	1	0	0	0	1	1	0	0
14300	0	0	1	0	0	0	0	1	0	0
14400	0	0	1	0	0	0	0	1	1	0
14500	0	0	1	0	0	0	0	0	1	0
14600	0	0	1	0	0	0	0	0	1	1
14700	0	0	1	0	0	0	0	0	0	1
14800	0	1	1	0	0	0	0	0	0	1
14900	0	1	1	0	0	0	0	0	1	1
15000	0	1	1	0	0	0	0	0	1	0
15100	0	1	1	0	0	0	0	1	1	0
15200	0	1	1	0	0	0	0	1	0	0
15300	0	1	1	0	0	0	1	1	0	0
15400	0	1	1	0	0	0	1	1	1	0
15500	0	1	1	0	0	0	1	0	1	0
15600	0	1	1	0	0	0	1	0	1	1
15700	0	1	1	0	0	0	1	0	0	1
15800	0	1	1	0	0	1	1	0	0	1
15900	0	1	1	0	0	1	1	0	1	1
16000	0	1	1	0	0	1	1	0	1	0
16100	0	1	1	0	0	1	1	1	1	0
16200	0	1	1	0	0	1	1	1	0	0
16300	0	1	1	0	0	1	0	1	0	0
16400	0	1	1	0	0	1	0	1	1	0
16500	0	1	1	0	0	1	0	0	1	0
16600	0	1	1	0	0	1	0	0	1	1

Altitude	D4	A1	A2	A4	B1	B2	B4	C1	C2	C4
16700	0	1	1	0	0	1	0	0	0	1
16800	0	1	1	0	1	1	0	0	0	1
16900	0	1	1	0	1	1	0	0	1	1
17000	0	1	1	0	1	1	0	0	1	0
17100	0	1	1	0	1	1	0	1	1	0
17200	0	1	1	0	1	1	0	1	0	0
17300	0	1	1	0	1	1	1	1	0	0
17400	0	1	1	0	1	1	1	1	1	0
17500	0	1	1	0	1	1	1	0	1	0
17600	0	1	1	0	1	1	1	0	1	1
17700	0	1	1	0	1	1	1	0	0	1
17800	0	1	1	0	1	0	1	0	0	1
17900	0	1	1	0	1	0	1	0	1	1
18000	0	1	1	0	1	0	1	0	1	0
18100	0	1	1	0	1	0	1	1	1	0
18200	0	1	1	0	1	0	1	1	0	0
18300	0	1	1	0	1	0	0	1	0	0
18400	0	1	1	0	1	0	0	1	1	0
18500	0	1	1	0	1	0	0	0	1	0
18600	0	1	1	0	1	0	0	0	1	1
18700	0	1	1	0	1	0	0	0	0	1
18800	0	1	1	1	1	0	0	0	0	1
18900	0	1	1	1	1	0	0	0	1	1
19000	0	1	1	1	1	0	0	0	1	0
19100	0	1	1	1	1	0	0	1	1	0
19200	0	1	1	1	1	0	0	1	0	0
19300	0	1	1	1	1	0	1	1	0	0
19400	0	1	1	1	1	0	1	1	1	0
19500	0	1	1	1	1	0	1	0	1	0
19600	0	1	1	1	1	0	1	0	1	1
19700	0	1	1	1	1	0	1	0	0	1
19800	0	1	1	1	1	1	1	0	0	1
19900	0	1	1	1	1	1	1	0	1	1
20000	0	1	1	1	1	1	1	0	1	0
20100	0	1	1	1	1	1	1	1	1	0
20200	0	1	1	1	1	1	1	1	1	0
20300	0	1	1	1	1	1	0	1	0	0
20400	0	1	1	1	1	1	0	1	1	0
20500	0	1	1	1	1	1	0	0	1	0
20600	0	1	1	1	1	1	0	0	1	1
20700	0	1	1	1	1	1	0	0	0	1
20800	0	1	1	1	0	1	0	0	0	1
20900	0	1	1	1	0	1	0	0	1	1
21000	0	1	1	1	0	1	0	0	1	0
21100	0	1	1	1	0	1	0	1	1	0
21200	0	1	1	1	0	1	0	1	0	0
21300	0	1	1	1	0	1	1	1	0	0
21400	0	1	1	1	0	1	1	1	1	0
21500	0	1	1	1	0	1	1	0	1	0
21600	0	1	1	1	0	1	1	0	1	1
21700	0	1	1	1	0	1	1	0	0	1
21800	0	1	1	1	0	0	1	0	0	1
21900	0	1	1	1	0	0	1	0	1	1
22000	0	1	1	1	0	0	1	0	1	0
22100	0	1	1	1	0	0	1	1	1	0
22200	0	1	1	1	0	0	1	1	0	0
22300	0	1	1	1	0	0	0	1	0	0
22400	0	1	1	1	0	0	0	1	1	0
22500	0	1	1	1	0	0	0	0	1	0
22600	0	1	1	1	0	0	0	0	1	1
22700	0	1	1	1	0	0	0	0	0	1

Altitude	D4	A1	A2	A4	B1	B2	B4	C1	C2	C4
22800	0	1	0	1	0	0	0	0	0	1
22900	0	1	0	1	0	0	0	0	1	1
23000	0	1	0	1	0	0	0	0	1	0
23100	0	1	0	1	0	0	0	1	1	0
23200	0	1	0	1	0	0	0	1	0	0
23300	0	1	0	1	0	0	1	1	0	0
23400	0	1	0	1	0	0	1	1	1	0
23500	0	1	0	1	0	0	1	0	1	0
23600	0	1	0	1	0	0	1	0	1	1
23700	0	1	0	1	0	0	1	0	0	1
23800	0	1	0	1	0	1	1	0	0	1
23900	0	1	0	1	0	1	1	0	1	1
24000	0	1	0	1	0	1	1	0	1	0
24100	0	1	0	1	0	1	1	1	1	0
24200	0	1	0	1	0	1	1	1	0	0
24300	0	1	0	1	0	1	0	1	0	0
24400	0	1	0	1	0	1	0	1	1	0
24500	0	1	0	1	0	1	0	0	1	0
24600	0	1	0	1	0	1	0	0	1	1
24700	0	1	0	1	0	1	0	0	0	1
24800	0	1	0	1	1	1	0	0	0	1
24900	0	1	0	1	1	1	0	0	1	1
25000	0	1	0	1	1	1	0	0	1	0
25100	0	1	0	1	1	1	0	1	1	0
25200	0	1	0	1	1	1	0	1	0	0
25300	0	1	0	1	1	1	1	1	0	0
25400	0	1	0	1	1	1	1	1	1	0
25500	0	1	0	1	1	1	1	0	1	0
25600	0	1	0	1	1	1	1	0	1	1
25700	0	1	0	1	1	1	1	0	0	1
25800	0	1	0	1	1	0	1	0	0	1
25900	0	1	0	1	1	0	1	0	1	1
26000	0	1	0	1	1	0	1	0	1	0
26100	0	1	0	1	1	0	1	1	1	0
26200	0	1	0	1	1	0	1	1	0	0
26300	0	1	0	1	1	0	0	1	0	0
26400	0	1	0	1	1	0	0	1	1	0
26500	0	1	0	1	1	0	0	0	1	0
26600	0	1	0	1	1	0	0	0	1	1
26700	0	1	0	1	1	0	0	0	0	1
26800	0	1	0	0	1	0	0	0	0	1
26900	0	1	0	0	1	0	0	0	1	1
27000	0	1	0	0	1	0	0	0	1	0
27100	0	1	0	0	1	0	0	1	1	0
27200	0	1	0	0	1	0	0	1	0	0
27300	0	1	0	0	1	0	1	1	0	0
27400	0	1	0	0	1	0	1	1	1	0
27500	0	1	0	0	1	0	1	0	1	0
27600	0	1	0	0	1	0	1	0	1	1
27700	0	1	0	0	1	0	1	0	0	1
27800	0	1	0	0	1	1	1	0	0	1
27900	0	1	0	0	1	1	1	0	1	1
28000	0	1	0	0	1	1	1	0	1	0
28100	0	1	0	0	1	1	1	1	1	0
28200	0	1	0	0	1	1	1	1	0	0
28300	0	1	0	0	1	1	0	1	0	0
28400	0	1	0	0	1	1	0	1	1	0
28500	0	1	0	0	1	1	0	0	1	0
28600	0	1	0	0	1	1	0	0	1	1
28700	0	1	0	0	1	1	0	0	0	1
28800	0	1	0	0	0	1	0	0	0	1

Altitude	D4	A1	A2	A4	B1	B2	B4	C1	C2	C4
28900	0	1	0	0	0	1	0	0	1	1
29000	0	1	0	0	0	1	0	0	1	0
29100	0	1	0	0	0	1	0	1	1	0
29200	0	1	0	0	0	1	0	1	0	0
29300	0	1	0	0	0	1	1	1	0	0
29400	0	1	0	0	0	1	1	1	1	0
29500	0	1	0	0	0	1	1	0	1	0
29600	0	1	0	0	0	1	1	0	1	1
29700	0	1	0	0	0	1	1	0	0	1
29800	0	1	0	0	0	0	1	0	0	1
29900	0	1	0	0	0	0	1	0	1	1
30000	0	1	0	0	0	0	1	0	1	0
30100	0	1	0	0	0	0	1	1	1	0
30200	0	1	0	0	0	0	1	1	0	0
30300	0	1	0	0	0	0	0	1	0	0
30400	0	1	0	0	0	0	0	1	1	0
30500	0	1	0	0	0	0	0	0	1	0
30600	0	1	0	0	0	0	0	0	1	1
30700	0	1	0	0	0	0	0	0	0	1
30800	1	1	0	0	0	0	0	0	0	1
30900	1	1	0	0	0	0	0	0	1	1
31000	1	1	0	0	0	0	0	0	1	0
31100	1	1	0	0	0	0	0	1	1	0
31200	1	1	0	0	0	0	0	1	0	0
31300	1	1	0	0	0	0	1	1	0	0
31400	1	1	0	0	0	0	1	1	1	0
31500	1	1	0	0	0	0	1	0	1	0
31600	1	1	0	0	0	0	1	0	1	1
31700	1	1	0	0	0	0	1	0	0	1
31800	1	1	0	0	0	1	1	0	0	1
31900	1	1	0	0	0	1	1	0	1	1
32000	1	1	0	0	0	1	1	0	1	0
32100	1	1	0	0	0	1	1	1	1	0
32200	1	1	0	0	0	1	1	1	0	0
32300	1	1	0	0	0	1	0	1	0	0
32400	1	1	0	0	0	1	0	1	1	0
32500	1	1	0	0	0	1	0	0	1	0
32600	1	1	0	0	0	1	0	0	1	1
32700	1	1	0	0	0	1	0	0	0	1
32800	1	1	0	0	1	1	0	0	0	1
32900	1	1	0	0	1	1	0	0	1	1
33000	1	1	0	0	1	1	0	0	1	0
33100	1	1	0	0	1	1	0	1	1	0
33200	1	1	0	0	1	1	0	1	0	0
33300	1	1	0	0	1	1	1	1	0	0
33400	1	1	0	0	1	1	1	1	1	0
33500	1	1	0	0	1	1	1	0	1	0
33600	1	1	0	0	1	1	1	0	1	1
33700	1	1	0	0	1	1	1	0	0	1
33800	1	1	0	0	1	0	1	0	0	1
33900	1	1	0	0	1	0	1	0	1	1
34000	1	1	0	0	1	0	1	0	1	0
34100	1	1	0	0	1	0	1	1	1	0
34200	1	1	0	0	1	0	1	1	0	0
34300	1	1	0	0	1	0	0	1	0	0
34400	1	1	0	0	1	0	0	1	1	0
34500	1	1	0	0	1	0	0	0	1	0
34600	1	1	0	0	1	0	0	0	1	1
34700	1	1	0	0	1	0	0	0	0	1
34800	1	1	0	1	1	0	0	0	0	1
34900	1	1	0	1	1	0	0	0	1	1
35000	1	1	0	1	1	0	0	0	1	0