



OPERATION & SERVICE MANUAL

**Model: 53D22004 (1008-50)
10 Ton (8.9 Metric Ton)
Axle Jack**

06/2019 – Rev. 01

REVISION
01

DATE
06/2019

TEXT AFFECTED
Original release

TABLE OF CONTENTS

	<u>PAGE</u>
1.0 PRODUCT INFORMATION	1
1.1 DESCRIPTION.....	1
1.2 MODEL & SERIAL NUMBER.....	1
1.3 MANUFACTURER	1
2.0 SAFETY INFORMATION.....	1
2.1 USAGE AND SAFETY INFORMATION	1
2.2 PRODUCT SAFETY	1
3.0 PREPARATION PRIOR TO FIRST USE	1
3.1 BLEED PROCEDURE	1
4.0 TRAINING.....	2
4.1 TRAINING REQUIREMENTS	2
4.2 TRAINING PROGRAM	2
4.3 OPERATOR TRAINING.....	2
5.0 OPERATION.....	2
5.1 PRE-OPERATION PROCEDURE.....	2
5.2 LIFTING PROCEDURE	2
5.3 LOWERING PROCEDURE.....	2
5.4 RELIEF VALVE SETTING	2
6.0 TROUBLE SHOOTING	3
7.0 MAINTENANCE.....	3
7.1 SPECIAL MAINTENANCE INSTRUCTIONS	3
7.2 SHOP AIDS AVAILABLE	3
7.3 OVERHAUL KITS AVAILABLE	3
8.0 PROVISION OF SPARES.....	3
8.1 SOURCE OF SPARE PARTS.....	3
8.2 RECOMMENDED SPARE PARTS LISTS	3
9.0 IN SERVICE SUPPORT.....	4
10.0 GUARANTEES/LIMITATION OF LIABILITY	4
11.0 APPENDICES	4

This product can not be modified without the written approval of Tronair, Inc. Any modifications done without written approval voids all warranties and releases Tronair, Inc., its suppliers, distributors, employees, or financial institutions from any liability from consequences that may occur. Only Tronair OEM replacement parts shall be used.

1.0 PRODUCT INFORMATION

1.1 DESCRIPTION

10 Ton (8.9 Metric Ton) Axle Jack

1.2 MODEL & SERIAL NUMBER

Reference nameplate on unit

1.3 MANUFACTURER

Columbus**Jack**/Regent
1 Air Cargo Pkwy East
Swanton, Ohio 43558 USA

Telephone: 614.443.7492
Fax: 614.444.9337
E-mail: sales@columbusjack.com
Website: www.columbusjack.com

1.5 SPECIFICATIONS

Capacity 10 Ton (8.9 Metric Ton)
Minimum Height 8 in (20.32 cm)
Hydraulic Lift 13 in (33.02 cm)
Extension Screw 4 in (10.16 cm)
Maximum Height 25 in (63.5 cm)
Operating Pressure 4565 psi (315 bar)
Relief Valve Pressure..... 5020 psi (346 bar)
Reservoir Capacity 3.6 pt (1.7 l)
Estimated Weight 50 lbs (22.7 kg)

2.0 SAFETY INFORMATION

2.1 USAGE AND SAFETY INFORMATION

To insure safe operations please read the following statements and understand their meaning. Also refer to your equipment manufacturer's manual for other important safety information. This manual contains safety precautions which are explained below. Please read carefully.



WARNING! — Warning is used to indicate the presence of a hazard that **can cause severe personal injury, death, or substantial property damage** if the warning notice is ignored.

CAUTION! — Caution is used to indicate the presence of a hazard that **will or can cause minor personal injury or property damage** if the caution notice is ignored.

2.2 PRODUCT SAFETY

Make sure all personnel involved with this jack read and understand these instructions before using.

WARNING!



The jack is designed to lift only vertical loads with a maximum weight of 10 ton (8.9 metric ton). Do not use jack for lifts exceeding the weight or design limits. Failure to comply can result in injury or death to personnel and/or severe damage to the jack and aircraft.

3.0 PREPARATION PRIOR TO FIRST USE

3.1 BLEED PROCEDURE

Using hand pump, cycle cylinder rams several times.

4.0 TRAINING

4.1 TRAINING REQUIREMENTS

The employer of the operator is responsible for providing a training program sufficient for the safe operation of the unit.

4.2 TRAINING PROGRAM

The employer provided operator training program should cover safety procedures concerning use of the unit in and around the intended aircraft at the intended aircraft servicing location.

4.3 OPERATOR TRAINING

The operator training should provide the required training for safe operation of the unit.

NOTE: Maintenance and Trouble Shooting are to be performed by a skilled and trained technician.

5.0 OPERATION

5.1 PRE-OPERATION PROCEDURE

1. Perform visual inspection, by checking for oil leakage.
2. Check for loose, damaged or missing parts.
3. Check oil level.

5.2 LIFTING PROCEDURE

1. Verify jack is located and load rated per airplane jacking procedures.
2. Raise extension screw to mate with airplane axle jacking point.
3. Close release valve.
4. Operate hand pump to raise aircraft as required.



CAUTION!

With no load applied to the jack, it is normal for any stage to extend first. Once a load is applied to the jack, ensure that the first stage ram (larger) is fully extended first, before the second stage ram (smaller) begins to extend. Ensure that the second stage ram (smaller) is fully extended before the third stage ram (smallest) begins to extend. If the jack does not extend in this sequence, the jack should be disassembled to determine the cause of the excessive friction in the ram stages.

5.3 LOWERING PROCEDURE

1. Slowly open release valve to lower rams.
2. Lower extension screw fully after rams are completely collapsed.

5.4 RELIEF VALVE SETTING

1. Position jack under a jack tester. Fully extend the first and second stage rams and partially extend the third stage.
2. Remove the plug from under the hand pump piston.
3. Set the relief valve at 10.50 - 11 tons as described in RJM 117. (See Appendix).



CAUTION!

Use care not to set valve more than 10% above rated capacity.



WARNING!

Do not exceed 11 tons.

4. Reinstall plug.

6.0 TROUBLE SHOOTING

If operational troubles are encountered, refer to the Trouble Shooting Chart which lists the most commonly occurring problems and gives information which will facilitate location of trouble source and determination of remedial action.

TROUBLE	PROBABLE CAUSE	REMEDY
Rams fail to lift when pump is operated or jack fails to lift rated load	Incomplete closure of release valve	Using slotted pump handle, fully tighten release valve
	Defective release valve causing the loss of system pressure	Remove release valve, o-ring and ball. Inspect and replace if necessary
	Low fluid level	Fill to correct fluid level
	By-pass valve setting incorrect	Remove screw-adjusting valve plug and adjusting pump plug gasket. Inspect setting of set screw and adjust clock-wise to increase system pressure
	Defective by-pass valve	Remove and replace valve
Rams will not fully elevate	Low fluid level	Fill to correct fluid level
	Leaking pressure valve	Remove and replace valve
Rams will not support load	Fluid leaks at rams	Remove cylinder bushing and first, second and third stage rams. Inspect ram bearings, o-ring, gaskets, backup rings and replace if necessary
	Leaking check valve	Remove valve assembly from jack base assembly. Remove and inspect valve pressure ball spring and ball. Replace if necessary
	Leaking release valve	Remove and inspect release valve, o-ring and ball. Replace if necessary
Rams elevate and fall with each pump stroke	Incomplete closure of release valve	Using slotted pump handle, tighten release valve
	Leaking release valve	Remove and inspect release valve, o-ring, and ball. Replace if necessary
	Leaking check valve	Remove valve assembly from jack base assembly. Remove and inspect valve retainer ring and ball. Replace if necessary
Pump inoperative or difficult to operate	Air lock or vacuum in reservoir due to closed vent assembly	Unscrew vent two turns
Rams will not lower	Defective release valve	Remove release valve, o-ring, and ball. Inspect and replace if necessary
	Loose retainer ring lodged beneath ram	Remove cylinder bushing and first, second and third stage rams. Inspect retainer rings and replace if necessary

7.0 MAINTENANCE

7.1 SPECIAL MAINTENANCE INSTRUCTIONS

There are no special maintenance instructions for this jack.

7.2 SHOP AIDS AVAILABLE

915-EBAdjuster Assembly

7.3 OVERHAUL KITS AVAILABLE

Soft Kit.....SKTES3-7

Repair KitTES3-7

8.0 PROVISION OF SPARES

8.1 SOURCE OF SPARE PARTS

Spare parts may be obtained from the manufacturer:

ColumbusJack/Regent

1 Air Cargo Pkwy East

Swanton, Ohio 43558 USA

Telephone: 614.443.7492

Fax: 614.444.9337

E-mail: sales@columbusjack.com

Website: www.columbusjack.com

8.2 RECOMMENDED SPARE PARTS LISTS

Reference the following page(s) for Replacement Parts and Kits available.

9.0 IN SERVICE SUPPORT

Contact Columbus Jack. for technical services and information. See Section 1.3 – Manufacturer.

10.0 GUARANTEES/LIMITATION OF LIABILITY

1. ColumbusJACK Corporation, (Seller) warrants each new product of its manufacture to be free from defects in material or workmanship, under proper, reasonable and normal use and service, and for a period of twelve (12) months after date of shipment from Seller's Swanton, OH. USA facility.
2. Where Buyer claims an alleged defect in material or workmanship and so advises Seller in writing within ten (10) days after discovery thereof, then and in such event, Buyer shall return said equipment, transportation prepaid, to the Seller, provided such return is timely and within twelve (12) months form date of original shipment. This warranty and liability of the Seller is expressly limited solely to replacement of repair of defective parts or goods, and return at Buyer's expense to Seller after find by Seller the product was defective prior to original shipment or, at the option of Seller, to making refund to Buyer of the purchase price for said product.
3. It is further expressly understood and agreed that:
 - a. THERE IS NO WARRANTY, representation of condition OF ANY KIND, express or implied, (INCLUDING NO WARRANTY OF MERCHANT-ABILITY OR OF FITNESS) EXCEPT THAT THE MATERIAL SHALL BE OF THE QUALITY SPECIFIED HEREIN, and none shall be implied by law. Except as otherwise provided herein, quality shall be in accordance with seller's specifications. Final determination of the material for the use contemplated by Buyer is the sole responsibility of Buyer and Seller shall have no responsibility in connection with such suitability, and
 - b. The Buyer's sole and exclusive remedy shall be repair or replacement of defective parts by the Seller. Should the goods, in the judgment of Seller, preclude the remedying of the warranted defects by repair or replacement, the buyer's sole and exclusive remedy shall the be the refund of the purchase price, and
 - c. Seller shall not be liable for prospective profits or special, indirect or consequential damages, nor shall any recovery of any kind against Seller be greater in amount than the purchase price of the specific material sold and causing the alleged loss, damage or injury. Buyer assumes all risk and liability for loss, damage or injury to persons or property of Buyer or others arising out of use or possession of any product or part sold hereunder, and
 - d. The Seller shall in no way be deemed or held to be obligated, liable or accountable upon or for any guarantees or warranties, express or implied, or created by statute or by operation of law or otherwise, in any manner of form beyond its express agreement above set forth, and
 - e. No warranty herein shall apply to any product which shall have been repaired or altered, unless such alteration or repair has been made by Seller or where, after return to and inspection by Seller, the product is found by Seller to have been subject to misuse, negligence or accident, and
 - f. No warranty of any nature is made by Seller as to any component forming a part of the product sold and Buyer shall receive only such warranties offered by such other manufacturer pertinent to such component, and
 - g. Seller does not assume nor does Seller authorize any other person to assume for it any other liability or make any warranty in connection with the sale of its products.

The obligations of ColumbusJACK expressly stated herein are in lieu of all other warranties or conditions expressed or implied. **Any unauthorized modification of the ColumbusJACK products or use of the ColumbusJACK products in violations of cautions and warnings in any manual (including updates) or safety bulletins published or delivered by ColumbusJACK will immediately void any warranty, express or implied and ColumbusJACK disclaims any and all liability for injury (WITHOUT LIMITATION and including DEATH), loss or damage arising from or relating to such misuse.**

11.0 APPENDICES

APPENDIX I Routine Jack Maintenance Bulletins

Parts List

When ordering replacement parts/kits, please specify model, serial number and color of your unit.

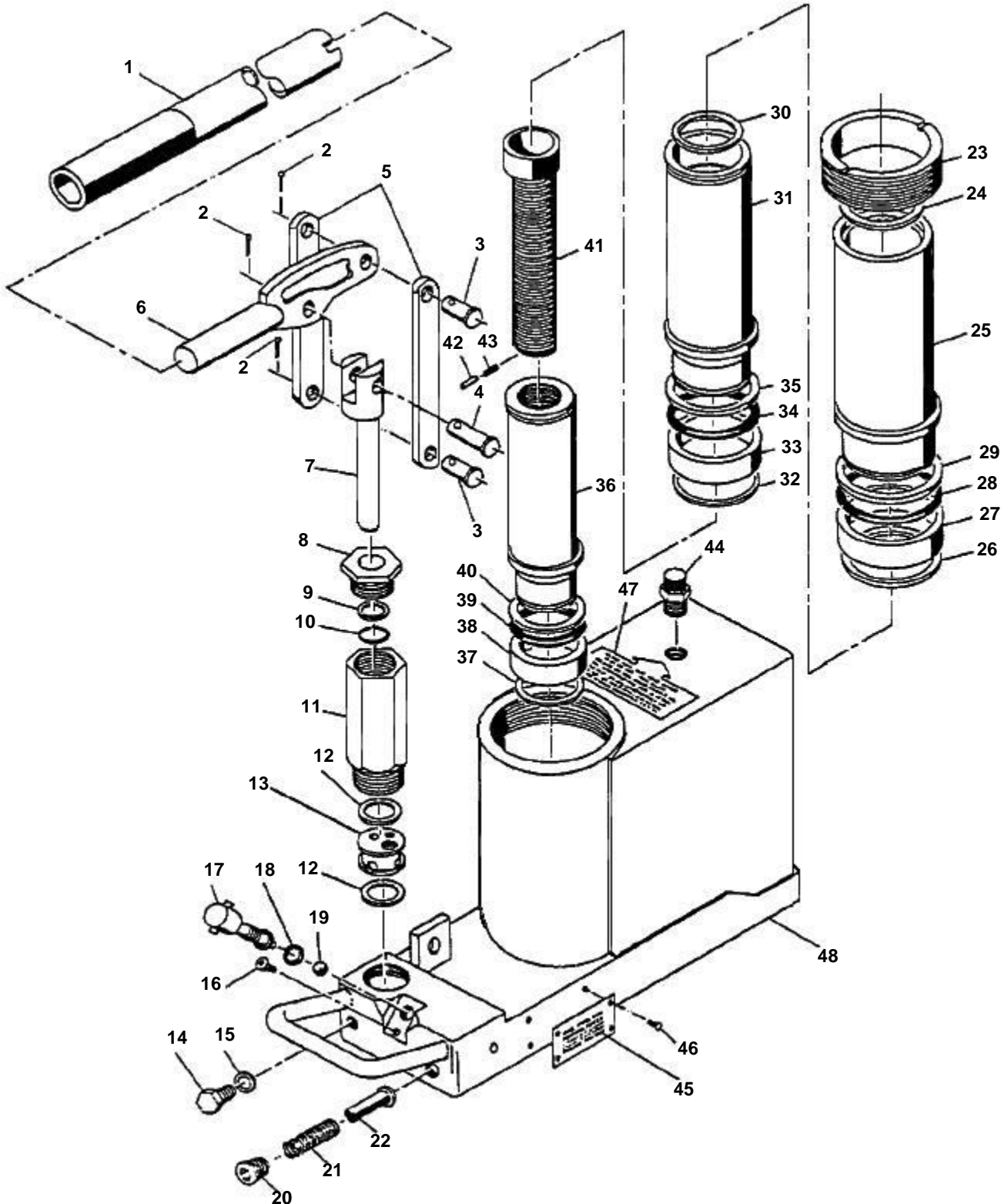

Parts List

When ordering replacement parts/kits, please specify model, serial number and color of your unit.

Item	Part Number	Description	Qty
1	53B22101	Pump Handle	
2	322-03240	Cotter Pin	3
3	321-14250	Clevis Pin	2
4	321-14330	Clevis Pin	1
5	53B22097-2	Link, Pump	2
6	53B22091	Rocker Arm	1
7	53A22103	Piston, Pump	1
8	53A22090	Nut, Packing	1
9	53B22036-1	Backup Ring	1
10	611-11211	O-Ring	1
11	53A22102	Pump Body	1
12	53A22099	Gasket	2
13	53C22096-3	Valve Assembly	1
14	53A22045	Screw-Adjusting Valve Plug	1
15	53A22098	Gasket	1
16	53A22043	Lock Screw, Release Valve	1
17	53A22157	Release Valve	1
18	611-01101	O-Ring	1
19	216-1-24	Ball	1
20	488-00006	Pipe Plug	1
21	53A22038	Spring	1
22	53A22044	Oil Screen	1
23	53A22010	Bushing	1
24	53C22035-9	Retainer Ring	1
25	53C22011	Ram, First Stage	1
26	53C22035-6	Retainer Ring	1
27	53A22015	Bearing, First Stage	1
28	611-33933	O-Ring	1
29	53C22069-4	Backup Ring	1
30	53C22035-10	Retainer Ring	1
31	53C22012	Ram, Second Stage	1
32	53C22035-7	Retainer Ring	1
33	53A22016	Bearing, Second Stage	1
34	611-33433	O-Ring	1
35	53C22069-5	Backup Ring	1
36	53B22018	Ram, Third Stage	1
37	53C22035-8	Retainer Ring	1
38	53A22017	Bearing, Third Stage	1
39	611-32932	O-Ring	1
40	53C22069-6	Backup Ring	1
41	53B22014	Extension Screw	1

Parts List

When ordering replacement parts/kits, please specify model, serial number and color of your unit.

Item	Part Number	Description	Qty
42	53A22041	Plunger	1
43	53A22040	Spring	1
44	50B7763	Air Vent Assembly	1
45	22004	Nameplate	1
46	450A6986	Drive Screw	4
47	53A22164	Decal, Air Vent	1
48	53D22007	Cylinder Base Weldment	1

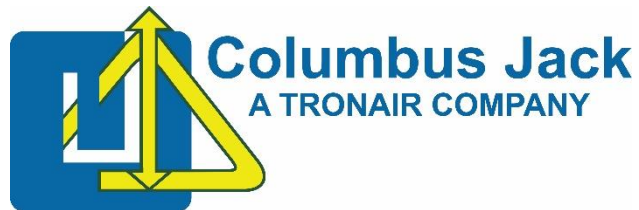

APPENDIX I

Routine Jack Maintenance Bulletins



Routine Jack Maintenance Bulletin

TO PROVIDE COMPLETE INFORMATION ON SERVICING
ColumbusJACK/REGENT QUALITY GROUND HANDLING EQUIPMENT

BULLETIN RJM 102 – PROCEDURE FOR WINTERIZATION OF HYDRAULIC AIRCRAFT JACKS

The following procedures should be utilized for optimum operational characteristics when using jacks at various temperature extremes:

1. Above 0°F (-18°C) Use MIL-PRF-5606, or equal, with no further additive required.
2. At 0° to -20°F (-18°C to 29°C) Use a mixture of 75% MIL-PRF-5606, or equal, and 25% kerosene.
3. Below -20°F (-29°C) Use a mixture of 50% MIL-PRF-5606, or equal, and 50% kerosene.

Due to most company, safety, or union regulations which restrict employees from working out-of-doors below -30°F (-34°C), there is a lack of experience beyond this point. It is permissible, however, to increase the percentage of kerosene up to 100%. As the ambient temperature increases, MIL-PRF-5606, should be added back to the system in the appropriate mixture.

The air supply should be clean and dry. At -30°F (-34°C), the air pump will start to react sluggishly and continue to operate less efficiently as the temperature decreases when a normal air supply is used. The problem can be eliminated by using a dry nitrogen source of sufficient capacity.

To ease the operation of the locknut(s) and screw extension, use "Never Freeze" by Snap-On, or equal, and apply liberally to the thread surfaces.



Routine Jack Maintenance Bulletin

TO PROVIDE COMPLETE INFORMATION ON SERVICING
ColumbusJACK/REGENT QUALITY GROUND HANDLING EQUIPMENT

BULLETIN RJM 116 –SCREW EXTENSION USAGE

When using a jack that has a screw extension, it is advisable that the screw extension be extended as far as possible, and still has the jack roll under the jacking point. If the screw extension is not properly extended, the aircraft may not be able to be raised to the desired height.

A periodic check should be made to the screw extension to ensure that the stop is operating properly to prevent over-extension. To do this, rotate the screw extension counterclockwise until it stops rotating. **DO NOT FORCE THE SCREW EXTENSION BEYOND THIS POINT.** If the screw extension does not stop rotating, remove it and repair the stop. **DO NOT USE WITHOUT THE SCREW EXTENSION STOP WORKING PROPERLY, AS THE JACK COULD FAIL WITH AN OVER-EXTENDED SCREW EXTENSION.**

BULLETIN RJM 117 – PROCEDURE FOR ADJUSTING CARTRIDGE STYLE RELIEF VALVES

It is imperative that safety relief valves on all jacks always be set between rated capacity, and rated capacity plus 10% maximum. The following procedure describes how to adjust cartridge style relief valves.

1. Position jack under jack tester.
2. Fully close release valve.
3. Remove access screw and seal. Install valve adjusting tool, Part No. 915-EB. (See illustration)

NOTE: If tool is not available, disregard this step.

4. Extend cylinder ram(s):
 - a. On single stage jacks, extend the ram approximately half way.
 - b. On multiple stage jacks, extend all rams until the smallest ram is extended approximately half way.
5. To set valves:
 - a. Using smooth, uniform pump handle strokes, manually pressurize the cylinder while monitoring either jack load gauge or load gauge on tester.
 - b. Pump handle shall "drop" or "go soft" at an indicated load between rated load and rated load plus 10% (ex: 50 ton jack should be between 50 and 55 tons).
 - c. If safety relief valve is set too high, release pressure and rotate adjusting screw counterclockwise. Repeat above steps until valve is adjusted in range.
 - d. If safety relief valve is set too low, release pressure and rotate adjusting screw clockwise. Repeat steps until valve is adjusted in range.

NOTE: If adjusting tool is not available, it is necessary to relieve pressure completely before removing valve access screw and seal. Then valve set screw can be adjusted using a 1/8 Inch Allen wrench. Valve access screw and seal must be Re-installed before jack can be re-pressurized.

6. After manual safety relief valve is adjusted, repeat above steps for air or electric pump if applicable.

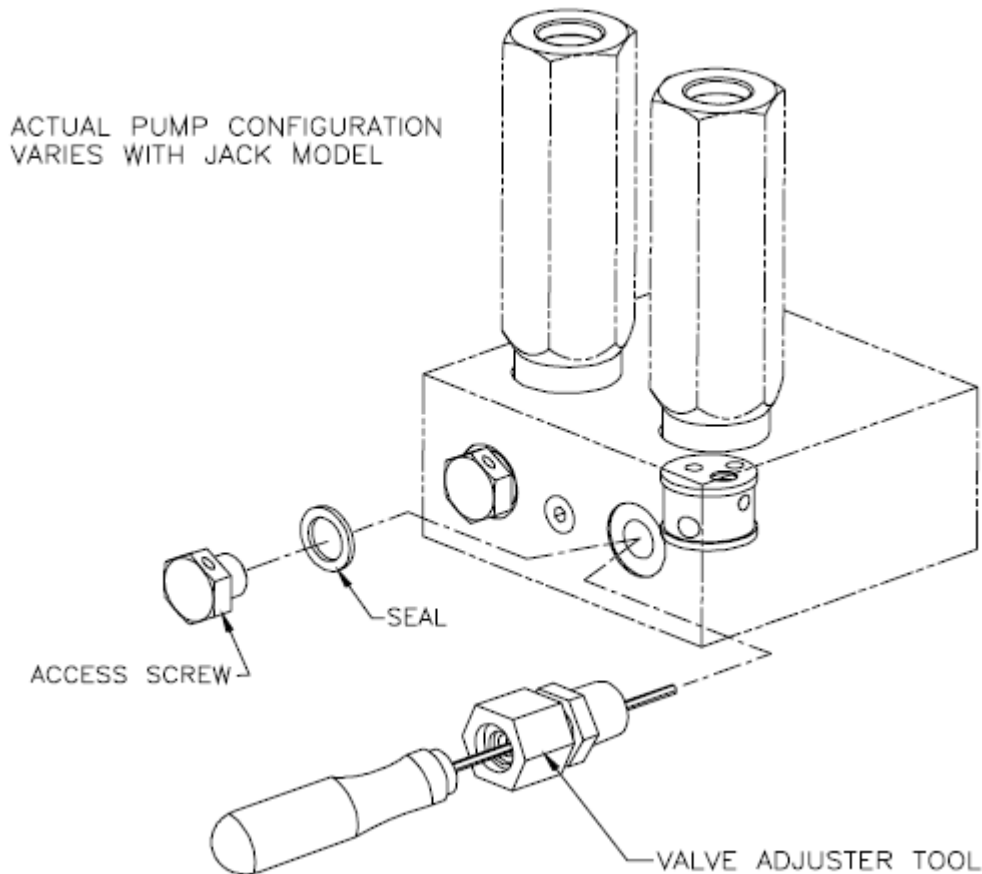

BULLETIN RJM 147 – RECOMMENDED ANNUAL JACK CERTIFICATION PROCEDURE

The following Recommended Annual Jack Certification Procedure is provided as a guide to insure that hydraulic aircraft jacks are always certified for operation. An annual time interval is a general recommendation only. The actual interval used should include factors for the climatic conditions in which the equipment is stored and the frequency of equipment use. Recommendations for Suggested Preventative Maintenance can be found in RJM 170.

1. With no external load applied to the jack, fully close release valve and fully extend ram(s) to verify function and the absence of external hydraulic leakage.



WARNING!

DO NOT APPLY PRESSURE AGAINST INTERNAL RAM STOP(S).

2. Open release valve and verify ram(s) retract fully.
3. Position jack under jack tester.

NOTE: For tripod jacks, all leg extensions should be installed on the jack.

4. Close release valve, and extend ram(s) until cup adapter contacts jack tester. Make sure that the ram of a single stage jack is partially extended and that the smaller ram of a multi-stage jack is partially extended.
5. Pressurize the jack against the jack tester. Using a calibrated pressure gauge on either the jack or the jack tester, monitor the pressure until the capacity (operating pressure) of the jack is reached.
6. With the jack pressurized against the jack tester, hold in this position for 3 minutes. Verify that the jack pressure has not decreased, indicating internal leakage.
7. Open the release valve to relieve jack pressure against the jack tester.
8. Set the safety relief valve per jack operation and maintenance manual.

BULLETIN RJM 149 – TEFLON BACKUP RING INSTALLATION PROCEDURE

When installing new Teflon backup rings on a ram or piston of any jack model, the following procedure should be observed to ensure correct installation of the ring. When installing a new backup ring, the corresponding o-ring should always be replaced also.

1. Cut existing o-ring and Teflon backup ring.
2. Clean and visually inspect the groove in the ram or piston for any nicks, scratches or score marks, which could cut the o-ring and backup ring during installation.
3. Check to ensure backup ring is clean and not damaged.
4. Set backup ring on a flat metal surface.
5. Using a propane torch, heat backup ring in a circular motion until backup ring is equally softened and pliable or flexible.
6. Carefully pick-up the HOT Teflon backup ring off the HOT metal plate and stretch the ring enough to fit over the end of the ram (piston).

NOTE: Make sure the "V" cup portion of the backup ring will face the o-ring. (see figure)

7. If backup ring does not return to size after cooling, re-heat backup ring while on the part, and cool quickly with a cold, wet towel or rag.
8. Check to ensure o-ring is clean and not damaged.
9. Carefully stretch o-ring over the end of the ram (piston). Ensure that the o-ring and the "V" cup of the backup ring are facing each other. (See figure)

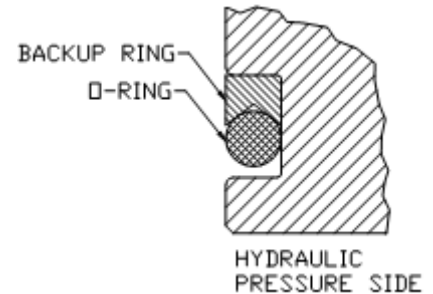



Routine Jack Maintenance Bulletin

TO PROVIDE COMPLETE INFORMATION ON SERVICING
ColumbusJACK/REGENT QUALITY GROUND HANDLING EQUIPMENT

BULLETIN RJM 170 – SUGGESTED PREVENTATIVE MAINTENANCE FOR JACKS

The following Preventative Maintenance Schedule is provided as a guide to insure that hydraulic aircraft jacks are always ready for operation. The time intervals listed are a general recommendation only. The actual interval used should include factors for the climatic conditions in which the equipment is stored and the frequency of equipment use.

Prior to Operation

1. Inspect for damaged or missing components.
2. Inspect for oil leakage and proper fluid level.
3. Inspect screw extension for mechanical stop.
4. Inspect all snap rings for engagement into grooves.
5. Inspect jack adapter for damage.

Every 6 Months

1. Inspect for worn snap ring grooves.
2. Change hydraulic filters if applicable.
3. If jack has not been used regularly, cycle jack without load.
4. Grease all lube fittings with a general purpose grease.
5. Wipe down ram(s) and screw extension with hydraulic oil.

Every 12 Months

1. Calibrate pressure gauge if applicable per RJM 173.
1. Perform "Recommended Annual Jack Certification Procedure" per RJM 147.



Routine Jack Maintenance Bulletin

TO PROVIDE COMPLETE INFORMATION ON SERVICING
ColumbusJACK/REGENT QUALITY GROUND HANDLING EQUIPMENT

BULLETIN RJM 171 – RECOMMENDED HYDRAULIC OILS

The following hydraulic oils are recommended for use in all ColumbusJACK/Regent products, though any oil compatible with Buna-N seals may be used. Proper oil level should be .5 to 1 inch below the fill port when all rams are collapsed.

Exxon/Mobil Aero HF (MIL-PRF-5606)
Exxon/Mobil DTE-11, -15
NATO Code No. H-538 (MIL-PRF-87257)
Phillips 66 X/C 5606
Royco 783 (Anderol) (MIL-PRF-6083)
Royco 782 (Anderol) (MIL-PRF-83282)
Shell Tellus 10, 15
Shell Aerofluid 31 (MIL-PRF-83282)
Shell Aerofluid 41 (MIL-PRF-5606)
Texaco Regal Oil R & O (32, 46, 100, 150, 220, 320, 460)