

**Model: 5833
Hydraulic Power Unit**



12/2021 – Rev. 06

REVISION	DATE	TEXT AFFECTED
01	02/2010	Original release
02	06/2016	Major revision
03	02/2017	Modified Hydraulic Schematic
04	12/2017	Modified 9.2 Electric Motor
05	08/2021	Added section 5.12 Infrequent HPU Use and updated 9.0 Maintenance
06	12/2021	Modified 9.7.3 Control Block Assembly

TABLE OF CONTENTS

	<u>PAGE</u>
1.0 PRODUCT INFORMATION.....	1
1.1 DESCRIPTION.....	1
1.2 MODEL & SERIAL NUMBER.....	1
1.3 MANUFACTURER.....	1
1.4 FUNCTION.....	1
1.5 REQUIREMENTS.....	1
2.0 SAFETY INFORMATION.....	2
2.1 USAGE AND SAFETY INFORMATION.....	2
2.2 EXPLANATION OF WARNING & DANGER SIGNS.....	2
2.3 COMPONENT SAFETY FEATURES.....	2
2.4 FUNCTIONAL SAFETY FEATURES.....	2
2.5 PERSONAL PROTECTION EQUIPMENT.....	2
2.6 SAFETY GUIDELINES.....	2
2.7 GENERAL COMMENTS.....	2
3.0 PREPARATION PRIOR TO FIRST USE.....	3
3.1 GENERAL.....	3
3.2 SERVICING RESERVOIR.....	3
3.3 CONNECTING ELECTRICAL LEADS.....	3
4.0 TRAINING.....	3
4.1 TRAINING REQUIREMENTS.....	3
4.2 TRAINING PROGRAM.....	3
4.3 OPERATOR TRAINING.....	3
5.0 OPERATION.....	4
5.1 OPERATING PARAMETERS.....	4
5.2 NUMERICAL VALUES.....	4
5.2.1 Fluid.....	4
5.2.2 Physical.....	4
5.2.3 Motor Driven Hydraulic Pump.....	5
5.2.4 Electric Motor.....	5
5.2.5 Filters.....	5
5.2.6 Hand Pump (<i>Option M</i>).....	5
5.3 LOCATION & LAYOUT OF CONTROLS.....	6
5.3.1 Front Panel Controls.....	6
5.3.2 Electrical Control Panel.....	7
5.3.3 Hydraulic Control Panel.....	8
5.3.4 Rear Panel Controls.....	9
5.3.5 Hydraulic Pump Controls.....	10
5.3.6 Hand Pump Controls (<i>Option M</i>).....	11
5.3.7 Split System Controls (<i>Option C</i>).....	12
5.4 START UP PROCEDURES.....	13
5.4.1 Pump Rotation Check Procedure (First Time Use or Change of Electrical Supply Only).....	13
5.4.2 Initial Start Up of the HPU.....	13
5.5 PRELIMINARY ADJUSTMENTS FOR OPERATION.....	13
5.5.1 Flow Control Adjustment.....	13
5.5.2 Pressure Control Adjustment.....	14
5.5.3 Reservoir Selector Valve Operation.....	14
5.5.4 Bypass Valve Operation.....	14
5.5.5 RETURN BACK-PRESSURE VALVE OPERATION.....	15
5.5.6 RETURN SIGHTGAUGE.....	15
5.6 BLEEDING AIR FROM SYSTEM.....	15
5.6.1 To Easily Purge the Unit of Air.....	15
5.7 SPLIT SYSTEM OPERATION.....	15
5.7.1 To Operate the Split System.....	16
5.8 HAND PUMP OPERATION (<i>Option M</i>).....	16
5.8.1 To Operate the Hand Pump.....	16
5.9 SAMPLE VALVE.....	16
5.10 EMERGENCY SHUT DOWN PROCEDURE.....	16
5.11 DESCRIPTION OF ALARM SYSTEMS.....	16
5.11.1 High Fluid Temperature Indicator.....	16
5.11.2 Voltage/Phase Monitor Indicator.....	16
5.11.3 High and Low Reservoir Level Indicator (<i>Option L</i>).....	16
5.11.4 Clogged Filter Indicator Light.....	17
5.12 INFREQUENT HPU USE.....	17
5.12.1 Infrequent HPU Use Start Up Procedure.....	17
6.0 PACKAGING AND STORAGE.....	18

6.1	PACKAGING REQUIREMENTS	18
6.2	HANDLING	18
6.3	PACKAGING PROTECTION	18
6.4	LABELING OF PACKAGING	18
6.5	STORAGE COMPATIBILITY	18
6.6	STORAGE ENVIRONMENT	18
6.7	STORAGE SPACE AND HANDLING FACILITIES	18
7.0	TRANSPORTATION	18
8.0	TROUBLE SHOOTING	19
8.1	HPU WILL NOT START	19
8.2	NO FLOW	19
8.3	REDUCED FLOW	20
8.4	NO PRESSURE or REDUCED PRESSURE	20
8.5	FLUID OVERHEATS.....	20
8.6	HAND PUMP (<i>Option M</i>) IS NOT PUMPING FLUID.....	20
9.0	MAINTENANCE	21
9.1	GENERAL.....	21
9.2	ELECTRIC MOTOR	21
9.3	MOTOR DRIVEN HYDRAULIC PUMP	22
9.3.1	Motor Driven Hydraulic Pump Replacement Parts.....	22
9.3.2	Motor Driven Hydraulic Pump Replacement Kits List.....	22
9.4	HYDRAULIC FLUID	23
9.5	FILTERS	23
9.5.1	Pressure Filter Element.....	24
9.5.2	Return Filter Element	25
9.5.3	Hand Pump (<i>Option M</i>) Filter Element	26
9.5.4	Desiccant Air Filter	27
9.5.5	Pressure Filter Assembly with Electric Filter Clogging Indicator	28
9.5.6	Return Filter Assembly.....	29
9.6	HYDRAULIC HOSES.....	30
9.7	INSTRUMENT PANEL.....	31
9.7.1	Electric Panel	32
9.7.2	Hydraulic Panel	33
9.7.3	Control Block Assembly	34
9.7.3.a	System Pressure Relief Valve.....	35
9.7.3.b	Check Valve.....	35
9.7.3.c	Bypass Valve	36
9.7.4	Pump Flow Control.....	37
9.8	RESERVOIR ASSEMBLY.....	39
9.9	PRESSURE MANIFOLD ASSEMBLY.....	41
9.10	RETURN MANIFOLD ASSEMBLY	42
9.10.1	Return System Pressure Relief Valve	43
9.11	ELECTRICAL COMPONENTS	45
9.12	HEAT EXCHANGER ASSEMBLY.....	47
9.13	EXTERNAL COMPONENTS.....	48
9.14	ADDITIONAL FEATURES	49
9.14.1	50 ft (15.2 m) Hoses (<i>Option B</i>).....	49
9.14.2	Electric Reservoir Level (<i>Option L</i>).....	49
9.14.3	Hand Pump (<i>Option M</i>)	50
9.14.3.a	Two Stage Pump with Relief	51
9.14.4	Towing Trailer (<i>Option N</i>).....	53
9.15	REPLACEMENT LABELS PARTS LISTS.....	54
9.15.1	Base Unit	54
9.15.2	Fluid Labels.....	54
9.15.3	Filter Element Kit Labels	54
9.15.4	Split System (<i>Option C</i>) Labels	55
9.15.5	Hand Pump (<i>Option M</i>) Labels.....	55
10.0	PROVISION OF SPARES	55
10.1	SOURCE OF SPARE PARTS.....	55
10.2	RECOMMENDED SPARE PARTS LISTS	55
10.2.1	Spare Electrical Parts.....	55
10.2.2	Spare Parts	55
11.0	CALIBRATION OF INSTRUMENTATION	56
11.1	SOURCE OF CALIBRATION.....	56
11.2	ANALOG PRESSURE GAUGE – System Pressure	56
11.2.1	Self Calibration.....	56
11.3	ANALOG PRESSURE GAUGE (Hand Pump Pressure- <i>Option M Only</i>)	57
11.3.1	Self Calibration.....	57

11.4	ANALOG TEMPERATURE GAUGE (<i>Pyrometer</i>)	57
11.4.1	Self Calibration.....	57
12.0	IN SERVICE SUPPORT	58
13.0	GUARANTEES/LIMITATION OF LIABILITY	58
14.0	APPENDICES	58

This product can not be modified without the written approval of Tronair, Inc. Any modifications done without written approval voids all warranties and releases Tronair, Inc., its suppliers, distributors, employees, or financial institutions from any liability from consequences that may occur. Only Tronair OEM replacement parts shall be used.

1.0 PRODUCT INFORMATION

1.1 DESCRIPTION

Hydraulic Power Unit

Model Number: 5833

Fluid Type: Aviation Phosphate Ester, Type IV

1.2 MODEL & SERIAL NUMBER

Reference nameplate on unit.

1.3 MANUFACTURER

TRONAIR, Inc.

1 Air Cargo Pkwy East

Swanton, Ohio 43558 USA

Telephone: (419) 866-6301 or 800-426-6301

Fax: (419) 867-0634

E-mail: sales@tronair.com

Website: www.tronair.com

1.4 FUNCTION

The Hydraulic Power Unit (HPU) provides a source of clean, pressurized hydraulic fluid for performing required aircraft maintenance. An electric motor drives a pressure compensated piston pump. Filters are provided on the pressure and return systems. A bypass (dump) valve allows starting and stopping of the unit under a no-load, safe condition. The unit may use either the aircraft or on-board HPU reservoir. Cooling is provided for continuous operation.

1.5 REQUIREMENTS

Adequate electrical power must be provided for proper functioning of the HPU. See the unit nameplate for proper voltage and frequency. See the Technical Manual for proper sizing of electrical supply and protection equipment in the facility.

2.0 SAFETY INFORMATION

2.1 USAGE AND SAFETY INFORMATION

The HPU provides pressurized hydraulic fluid for performing aircraft maintenance.

To insure safe operations please read the following statements and understand their meaning. Also refer to your equipment manufacturer's manual for other important safety information. This manual contains safety precautions which are explained below. Please read carefully.



WARNING! — Warning is used to indicate the presence of a hazard that **can cause severe personal injury, death, or substantial property damage** if the warning notice is ignored.

CAUTION! — Caution is used to indicate the presence of a hazard that **will or can cause minor personal injury or property damage** if the caution notice is ignored.

2.2 EXPLANATION OF WARNING & DANGER SIGNS



Accidental Starts! Before servicing the HPU or equipment, always disconnect electrical power supply to prevent accidental starting.



Rotating Parts! Keep hands, feet, hair, and clothing away from all moving parts to prevent injury. Never operate the HPU with covers, shrouds, or guards removed.



Electrical Shock! Never touch electrical wires or components while the HPU is attached to the power source. They can be sources of electrical shock. **DO NOT** operate HPU with cabinet panels removed.



Pressurized Fluid! Before servicing the HPU or equipment, always open the bypass valve to relieve any residual pressure in the hydraulic system.

2.3 COMPONENT SAFETY FEATURES

- Pump/Motor coupling guard
- Sheet metal panels
- Pressure and return system relief valves
- Control circuit fuses
- Motor overload protection
- 3- Phase Power Input Fuses

2.4 FUNCTIONAL SAFETY FEATURES

- Emergency shut off switch
- Floor lock
- Calibration port shut off valve
- Fluid sample shut off valve

2.5 PERSONAL PROTECTION EQUIPMENT

- Safety glasses must be worn when operating the HPU.
- Additional equipment recommended by the fluid manufacturer (gloves, etc.). **Reference Appendix VII Material Safety Data Sheet pertaining to fluid(s).**

2.6 SAFETY GUIDELINES

- Operator must be properly trained prior to operating the HPU.
- HPU power switch must be in "Off" position when connecting or disconnecting hoses to the aircraft.
- Bypass valve must be in the "Open" position when starting or stopping the HPU.
- Electrical power must be disconnected from the HPU and the bypass valve must be in the "Open" position before servicing the HPU.

2.7 GENERAL COMMENTS

The HPU is intended to be operated by personnel trained in the proper use in conjunction with the aircraft maintenance manual.

The HPU must be used in accordance with the Technical and Operator Manuals and the intended aircraft.

3.0 PREPARATION PRIOR TO FIRST USE

3.1 GENERAL

Prior to operating the HPU, the user should become familiar with this Operator Manual.

3.2 SERVICING RESERVOIR

Fill the reservoir with the correct fluid (see label next to reservoir fill for correct type of fluid) until fluid level is above the minimum fluid level mark but below the maximum fluid level. See Figure 6.3.1 Front Panel Controls for reservoir fill location.

NOTE: Leave the Reservoir Selector Valve in the Aircraft Reservoir position (as shipped) until the Hydraulic Power Unit reservoir has been filled.

3.3 CONNECTING ELECTRICAL LEADS



Electrical Shock! Never touch electrical wires or components while electrical power is attached. Only qualified electricians should connect the electrical leads.

Install the proper electrical plug onto the electrical cord. Read **5.0 Training** and **6.0 Operation** of this manual and become familiar with control locations. Reference **5.1 Electrical Power and Protection Requirements Table** for power requirements and fuse sizes. Follow instructions in **5.4.1 Pump Rotation Checking Procedure**.

WARNING!



Balanced three phase voltage must be available to prevent overheating and damage to the motor.

Voltage unbalanced between phases occurs when the voltages differ from one another.

Some reasons for imbalance are:

1. **Unequal loading of each phase**
2. **Poor connections in the supply**
3. **Single phase condition caused by blown fuses or bad connections**

If these conditions occur in the incoming power system, a protective device, such as a voltage monitor, should be installed on the machine to prevent motor damage.

4.0 TRAINING

4.1 TRAINING REQUIREMENTS

The employer of the operator is responsible for providing a training program sufficient for the safe operation of the HPU.

4.2 TRAINING PROGRAM

The employer provided operator training program should cover safety procedures concerning use of the HPU in and around the intended aircraft at the intended aircraft servicing location.

4.3 OPERATOR TRAINING

The operator training should provide the required training for safe operation of the HPU.

NOTE: Maintenance and Trouble Shooting are to be performed by a skilled and trained technician.

5.0 OPERATION

5.1 OPERATING PARAMETERS

- The user shall use the HPU in accordance with the aircraft manufacturer's instructions.
- The user shall operate the HPU in accordance with the Technical and Operator Manuals.
- The employer of the operator shall provide all necessary training.
- The electrical power supply for the HPU must include a fused disconnect using Type J or Type R fuses or equivalent magnetic type circuit breakers designed for protecting an electrical motor. This necessary equipment is for protection of the HPU, power cord, and customer-supplied plug and receptacle. *Reference the Table below:*

ELECTRICAL POWER AND PROTECTION REQUIREMENTS

60 Hz Applications			
Voltage	380	460	575
Full Load Amps	130	121	96.8
Locked Rotor Amps	908	789	632
Recommended Fuse Size	175	150	125
Maximum Fuse Size	200	175	150

50 Hz Applications			
Voltage	380	415	440
Full Load Amps	146	134	124
Locked Rotor Amps	849	778	734
Recommended Fuse Size	200	175	150
Maximum Fuse Size	200	200	175

5.2 NUMERICAL VALUES

5.2.1 Fluid

Model Number: 5833

Fluid Type: Aviation Phosphate Ester, Type IV

5.2.2 Physical

- Weight (Dry): 6,000 lbs (2722 kg) Estimated
- Dimensions:
 - Width 80.3 in (204 cm) Add 6.0 in (15.2 cm) for Split System
 - Height 68 in (173 cm)
 - Depth 105 in (266 cm) Add 11 in (25 cm) for trailer option
- Power Cord: 50 ft (15.24 m) long
- Pressure Hoses:
 - 25 ft (7.62 m)..... Standard Length
 - 50 ft (15.24 m)..... Optional Length
 - 16 (1 in, 25.4 mm)..... Working Diameter
- Return Hoses:
 - 25 ft (7.62 m)..... Standard Length
 - 50 ft (15.24 m)..... Optional Length
 - 24 (1½ in, 38.1 mm)..... Working Diameter
- Hand Pump Hose:
 - 15 ft (4.57 m)..... Standard Length
 - 4 (¼ in, 6.35 mm) Working Diameter

5.2.3 Motor Driven Hydraulic Pump

- A pressure compensated, adjustable maximum volume piston pump.
- Maximum flow at 60 Hz..... 63 gpm (239 lpm)
- Maximum flow at 50 Hz..... 53 gpm (200 lpm)
- Maximum operating pressure at 50 Hz and 60 Hz 4,000 psi (276 bar)
- System pressure relief valve setting..... 4,250 psi (293 bar)
- Performance Curve for 50 Hz and 60 Hz

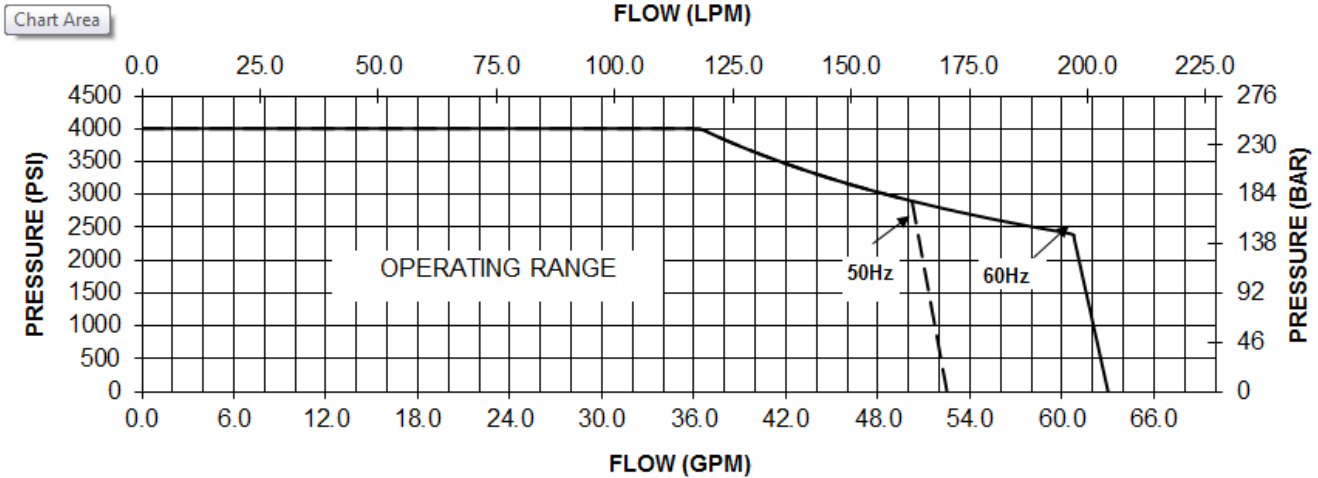

5.2.4 Electric Motor

A 100 horsepower, TEFC electric motor is the prime mover for the HPU. This is attached to the hydraulic pump using a pump/motor adapter and a spider/coupling rotating interface.

MOTOR POWER REQUIREMENTS

60 Hz Applications		50 Hz Applications	
Voltage	Full Load Amps	Voltage	Full Load Amps
380	130	380	146
460	121	415	134
575	96.8	440	124

5.2.5 Filters

- Pressure..... 2 micron rating, non-bypass high collapse microglass type. Non-cleanable element.
- Return 5 micron rating, 25 psi (1.72 bar) bypass microglass type. Non-cleanable element.
- Hand Pump (*Option M*) 2 micron rating, non-bypass microglass type. Non-cleanable element.
- Air/Desiccant..... 3 micron filter, silica gel desiccant type. Non-cleanable element.

5.2.6 Hand Pump (*Option M*)

Two stage hand pump, low pressure stage 0–500 psi (0–34.47 bars) and 500–5,000 psi (34.47–344.74 bars) high pressure stage. Pump automatically changes stage internally based on system pressure.

- Low Pressure Stage:
- Piston Diameter..... 1½ in (38.1 mm)
 - Working Pressure..... 0–500 psi (0–34.47 bar)
 - Displacement/Stroke 2.1 in3 (34.4 cm3)
 - Force/100 psi (6.89 bar) 12.0 lbs/100 psi (7.74 N/bar)
- High Pressure Stage:
- Piston Diameter..... 5/8 in (15.88 mm)
 - Working Pressure..... 500–5,000 psi (34.47–344.74)
 - Displacement/Stroke 0.4 in3 (6.55 cm3)
 - Force/100 psi (6.89 bar) 2.2 lbs/100 psi (1.42 N/bar)
- Pressure Relief Setting: 5,250 psi (362.0 bar)

5.3 LOCATION & LAYOUT OF CONTROLS

5.3.1 Front Panel Controls

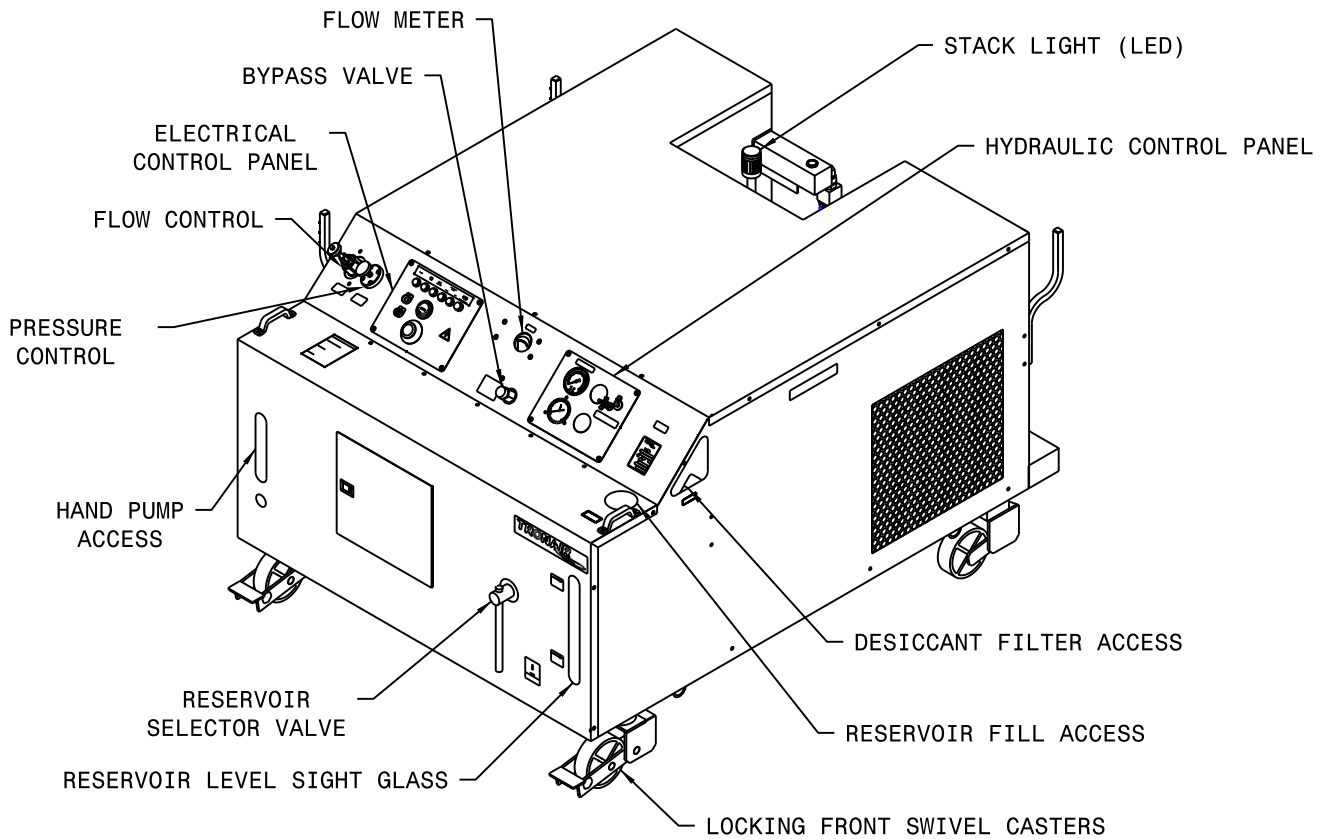

Electrical Control Panel	See Section 6.3.2
Hydraulic Control Panel	See Section 6.3.3
Bypass Valve	For loading and unloading the motor driven hydraulic pump
Flowmeter	Displays the flow from the motor driven hydraulic pump
Reservoir Selector	For selecting between using the aircraft reservoir or the HPU reservoir
Sight Gauge	Visual indicator displays the fluid level in the reservoir
Reservoir Fill Access	Locking cap for servicing the HPU reservoir
Desiccant Filter	Access to the reservoir air filter/desiccant filter
Hand Pump (<i>Option M</i>)	Access for hand pump and relief screw, handle stored inside
Locking Swivel Caster	Locking/unlocking, foot actuated and released locking front caster
Stack Light (<i>Option SL</i>)	Displays green LED light when unit is running
Flow Control	See 6.3.5 Hydraulic Pump Controls
Pressure Control	See 6.3.5 Hydraulic Pump Controls

5.3.2 Electrical Control Panel

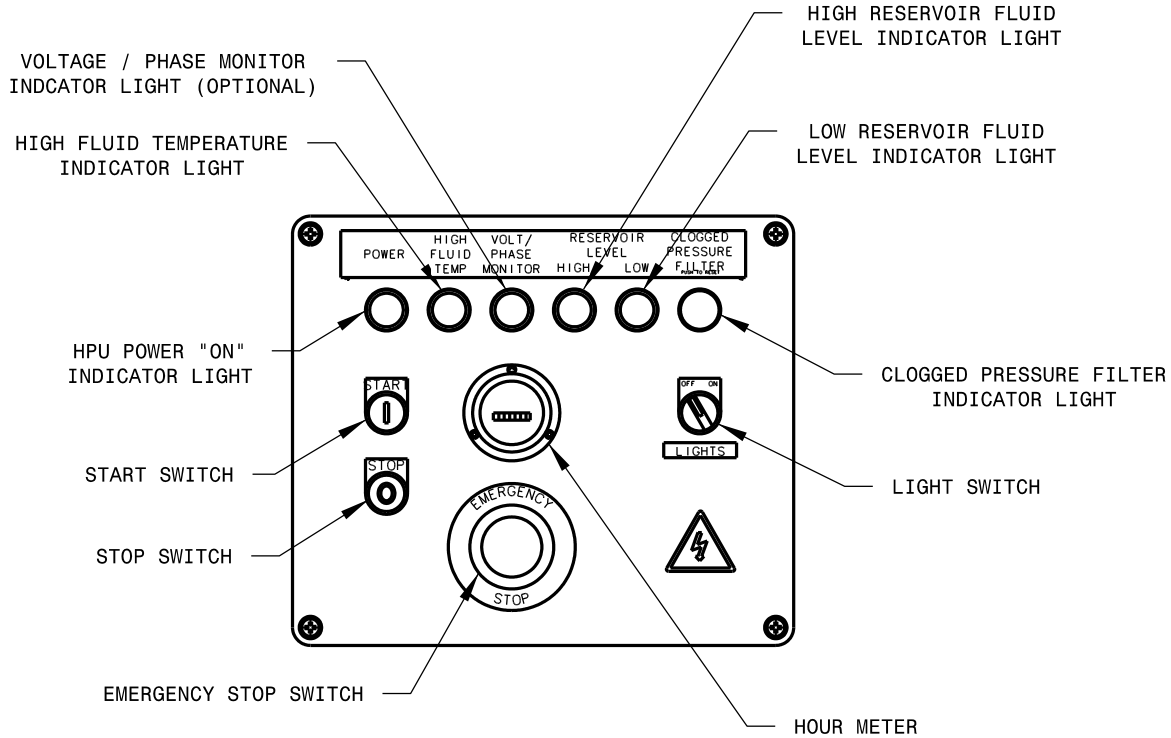

Emergency Stop	Removes power to all electrical devices, must turn to reset
Stop Switch	Turns off the electric motors driving the hydraulic pump and cooling fan
Start Switch	Turns on the electric motors driving the hydraulic pump and cooling fan
HPU Power "On" Indicator Light	Light is illuminated when the electric motors driving the hydraulic pump and cooling fan are on
High Fluid Temperature Indicator Light	Light is illuminated when the return fluid temperature reaches 160° F (71° C) or above. The HPU will shut down when light is illuminated. The HPU can be re-started when the fluid has cooled and the indicator light is off
High Reservoir Fluid Level Indicator Light	Light is illuminated when the fluid level in the reservoir is above the normal operating range. The HPU will shut down until the fluid level is restored to a normal operating level
Light Switch	Turns on lights for viewing return sight gauge instrumentation in low light conditions
Low Reservoir Fluid Level Indicator Light	Light is illuminated when the fluid level in the reservoir is below the normal operating range. The HPU will shut down until the fluid level is restored to a normal operating level
Voltage/Phase Monitor Indicator Light	Light is illuminated if any of the following conditions occur <ul style="list-style-type: none"> - Voltage imbalance between L1, L2, L3, greater than 5% - Loss of voltage from L1, L2, L3 - Over voltage from L1, L2, L3, greater than 5% - Change in phase orientation between L1, L2, L3. The HPU will shut down until the electrical problem is corrected
Clogged Pressure Filter Indicator Light	Light is illuminated when the pressure filter element requires changing. The HPU will not shut down when illuminated. Pressing the illuminated button will reset the light

5.3.3 Hydraulic Control Panel

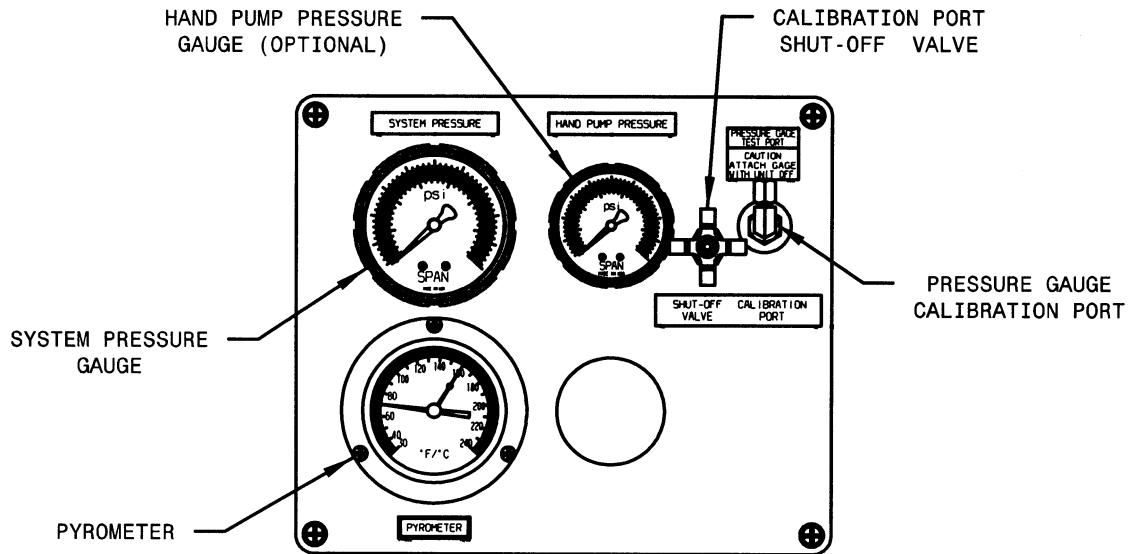

System Pressure Gauge	Displays the system pressure on an analog fluid dampened gauge
Pyrometer	Displays the fluid temperature in the return system on an analog gauge. A warning indicator preset to 160° F (71° C) warns of high operating temperature
Pressure Gauge Calibration Port	Allows for calibration of the system pressure gauge up to the operating pressure of HPU. Calibration port shut off valve must be used in conjunction with the calibration port
Calibration Port Shut Off Valve <i>(Part of Calibration Port)</i>	Used to shut off pressure to the calibration port. This valve should only be opened when the external standard gage is attached. (See Operation & Service Manual for proper procedure)
Hand Pump Pressure Gauge <i>(Option M)</i>	Displays the hand pump system pressure on an analog fluid dampened gauge

5.3.4 Rear Panel Controls

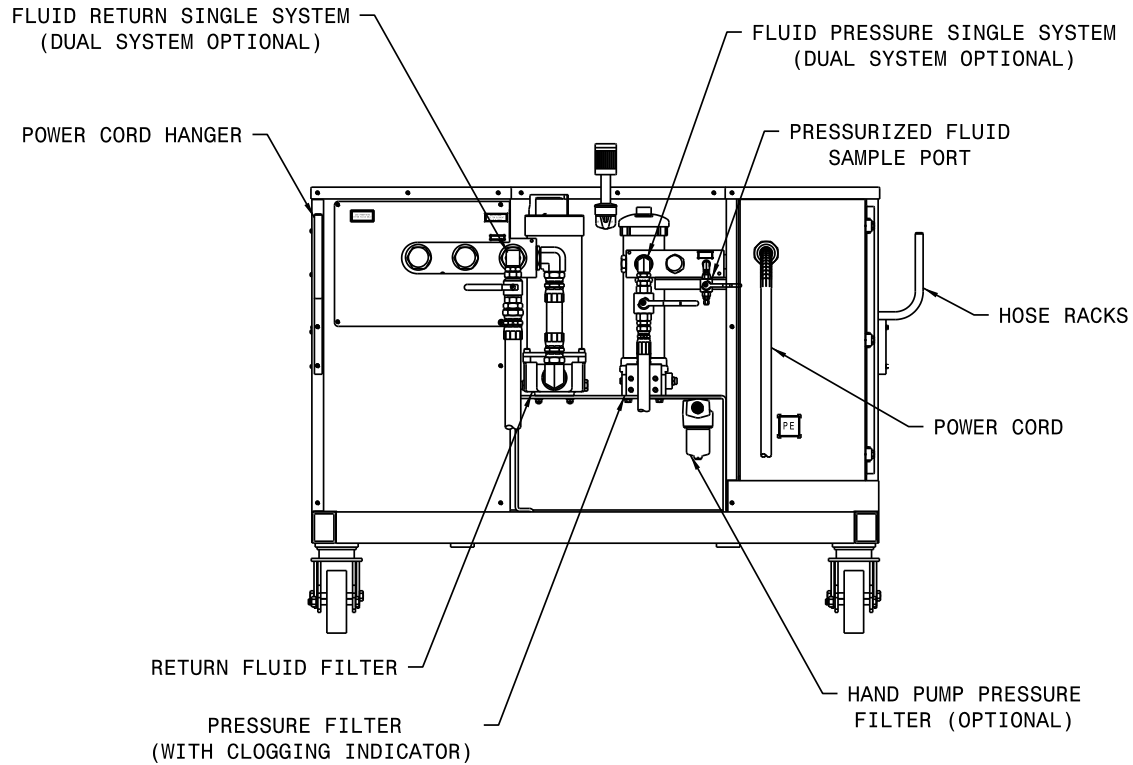

* Fluid Pressure System	The source of pressurized fluid from the HPU that flows to the aircraft pressure system through the pressure hose
* Fluid Return System	Fluid returning to the HPU from the aircraft that flows through the return hoses
Pressure Fluid Filter	Filters the pressurized fluid before it flows to the aircraft pressure system
Return Fluid Filter	Filters the fluid returning from the aircraft before it enters the HPU
Pressurized Fluid Sample Port	A sample valve is provided to obtain a fluid sample for analysis. In order to obtain a representative sample, it is suggested that ANSI/B93.19M-1972(R1993) be followed
Hand Pump Pressure Filter (Option M)	Filters the pressurized fluid before it flows to the aircraft system
Hose Racks	Location for storing the pressure, return and optional hand pump hoses when not in use
Power Cord Hanger	Location for storing the power cord when not in use

* **Split System (Optional) consists of two (2) each of these items.**

5.3.5 Hydraulic Pump Controls

The hydraulic pump flow control and pressure control are located through the pump control access door.

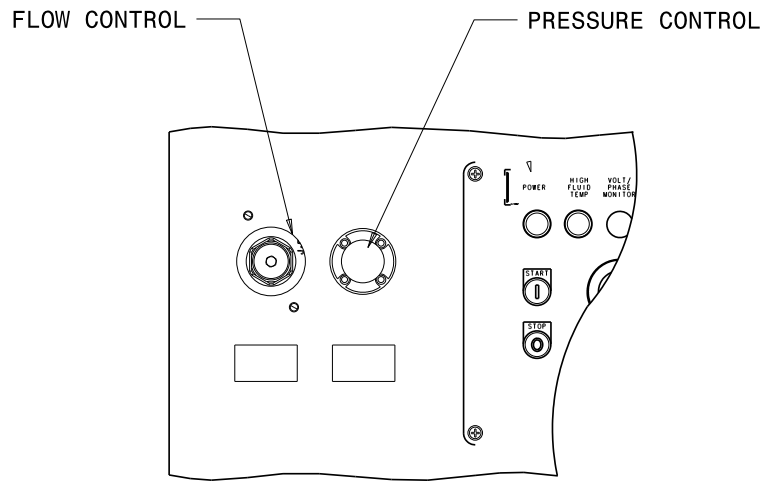

Flow Control	This control is used to set the maximum flow required from the HPU
Pressure Control	The pressure control is used to set the system pressure of the HPU during operation

5.3.6 Hand Pump Controls (*Option M*)
Reference 5.8 Hand Pump Operation

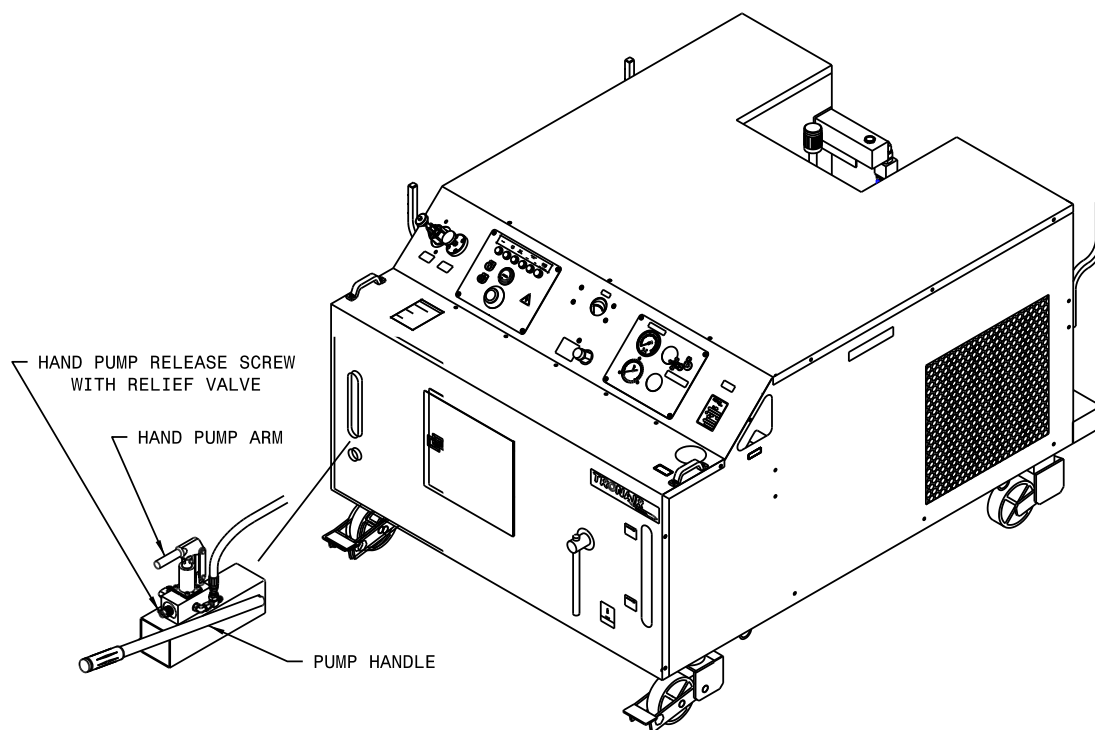

Pump Handle	Located inside the front access door is the hand pump handle used for opening and closing the hand pump relief screw and stroking the hand pump arm
Hand Pump Relief Screw	Accessed through the front panel opening, this screw allows opening and closing of the hand pump hydraulic circuit using the hand pump handle
Hand Pump Arm	The handle is used to access the hand pump arm used for up and down motion to produce hydraulic flow and pressure

5.3.7 Split System Controls (Option C)
Reference 5.7 Split System Operation

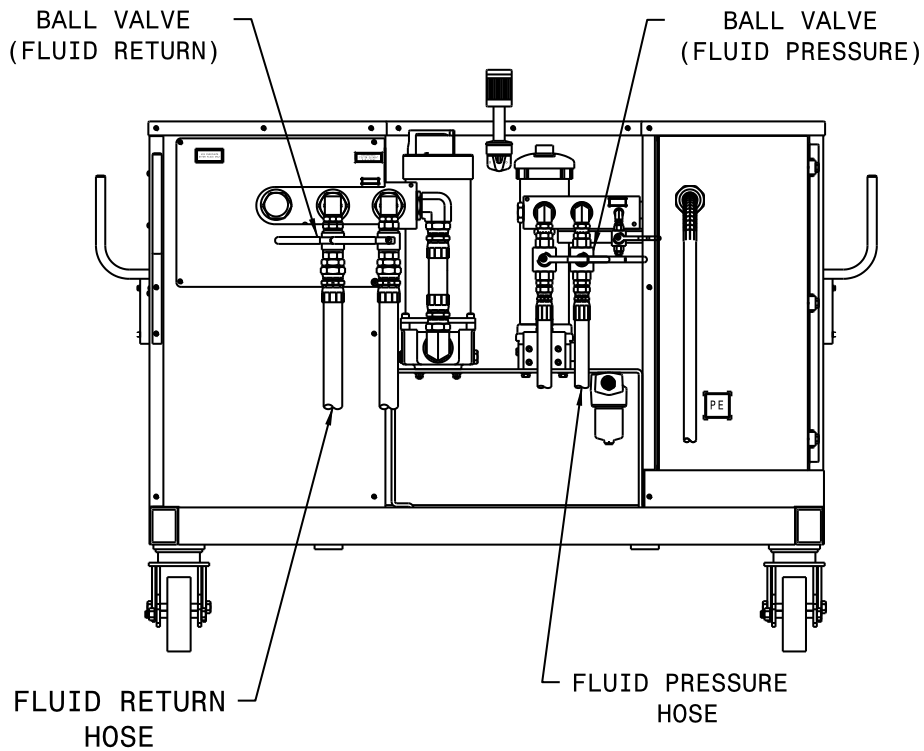

Fluid Pressure Ball Valve	Used to turn on and off the flow to separate aircraft systems. Always use in either fully open or fully closed position; never use in a partially open position
Fluid Pressure Hose	Connects HPU to aircraft pressure systems
Fluid Return Hose	Connects HPU to aircraft return systems
Fluid Return Ball Valve	Used to turn on and off the flow from separate aircraft systems. Always use in either fully open or fully closed position; never use in a partially open position

WARNING!



NEVER open or close split system valves without shutting off the Hydraulic Power Unit. Damage to the aircraft system or reservoir may result if either return line valve is closed while the machine is running.

5.4 START UP PROCEDURES

5.4.1 Pump Rotation Check Procedure (First Time Use or Change of Electrical Supply Only)

Phase Monitor (Options H – J Only): Check that the phase monitor light on the instrument panel is not illuminated. If the light is illuminated, change any two of the three input leads at the plug. Once the phase monitor light is not illuminated with power attached, check for proper motor rotation.

To check rotation (with or without Phase Monitor):

- Close the fluid pressure ball valve(s) at the rear of the HPU. Reference **5.3.4** for location of ball valve.
- Open the bypass valve on the instrument panel fully counter-clockwise.
- Set the flow control on the pump to maximum flow (fully counter-clockwise).
- Place the reservoir selector valve in HPU Reservoir position.
- Remove the pump/motor coupling guard. Reference Pump/Motor Coupling Access. figure

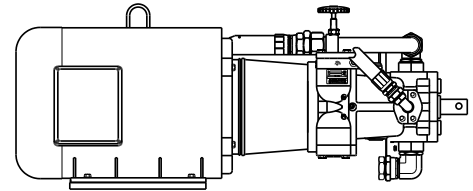

Pump/Motor Coupling Access



Rotating Parts! Keep hands, feet, hair, and clothing away from all moving parts to prevent injury. Never operate the HPU with covers, shrouds, or guards removed.



Electrical Shock! Never touch electrical wires or components while the HPU is attached to the power source. They can be sources of electrical shock. Do not operate HPU with cabinet panels removed.

- Verify that the unit has been prepared for use by connecting electrical leads and servicing the reservoir. (Reference 3.0 Preparation Prior to First Use)
- Keeping hands clear of the pump/motor coupling area, momentarily press the start button and immediately press the stop button.
- Observe direction of rotation of the pump/motor coupling. When the Operator is facing the front panel, the pump/motor coupling should be rotating in a clockwise direction.
- If the pump/motor coupling is rotating in a counter-clockwise direction, change any two of the three leads at the plug.
- Observe direction of rotation to verify that pump/motor is rotating in a clockwise direction.
- Replace the pump/motor coupling guard.

5.4.2 Initial Start Up of the HPU

- Unit must be prepared per **4.0 Preparation Prior to First Use** and **6.4.1 Pump Rotation Check Procedure (First Time Use or Change of Electrical Supply Only)** before starting the HPU.
- Operator must be familiar with this manual and be properly trained prior to starting the HPU.
- Close the fluid pressure ball valve(s) at the rear of the HPU. Reference **5.3.4** for location of ball valve.
- Open the bypass valve on the instrument panel fully counter-clockwise.
- Set the flow control on the pump to maximum flow (fully counter-clockwise).
- Place the reservoir selector valve in HPU Reservoir position.
- Press the start switch; the flowmeter should show full flow immediately. If no flow displays on the flow meter, press the stop switch immediately and reference **8.2 No Flow** in Trouble Shooting section.
- Adjust the flow down to approximately 10–20 gpm (38–76 lpm).
- Close the bypass valve, adjust the pressure control until 3,000 psi (206.84 bar) is displayed on the pressure gauge. (If no pressure displays on the system pressure gauge after adjusting the pressure control, reference **Trouble Shooting 8.4 No Pressure or Reduced Pressure**).
- Open the bypass valve; press the stop switch

NOTE: Maintenance and Trouble Shooting are to be performed by a skilled and trained technician.

5.5 PRELIMINARY ADJUSTMENTS FOR OPERATION

The following are basic to the operation of the HPU and should be thoroughly understood. The pressure and flow controls have lock nuts to prevent rotation of the control shaft during operation. These nuts should be moved away from the pump during adjustment of flow or pressure in order to eliminate binding of the control shafts.

5.5.1 Flow Control Adjustment

- Open bypass valve.
- Select "Hydraulic Power Unit" position with reservoir selector valve.
- Start HPU.
- Adjust flow control on pump for maximum desired flow. Observing the flowmeter, read flow in gallons (liters) per minute directly from flowmeter. Be sure the control shaft lock nut is loose during adjustment. Tighten after adjustment to maintain setting.

5.5.2 Pressure Control Adjustment

- a. Open bypass valve.
- b. Select "Hydraulic Power Unit" position with reservoir selector valve.
- c. Start HPU.
- d. Close bypass valve.
- e. Adjust pressure control for desired pressure; observing the system pressure gauge, read in psi (bars). Be sure the control shaft lock nut is loose during adjustment. Tighten after adjustment to maintain setting.

NOTE: *Once the flow and pressure controls have been adjusted, it is not necessary to change these settings after each operation unless desired.*

5.5.3 Reservoir Selector Valve Operation

Operation of the reservoir selector valve allows the operator to select either the aircraft reservoir (closed loop) or the HPU reservoir (open loop).

CAUTION!



The reservoir selector valve should only be operated when the HPU is not running. The operation of the reservoir selector valve should be done prior to starting the HPU.

a. Aircraft Reservoir Position (Closed Loop)

In this position, the HPU is dependent on the aircraft reservoir and system for an adequate supply of fluid. Cavitation, due to an inadequate fluid supply from the aircraft, may be indicated by erratic fluctuation of the system pressure gauge or flowmeter. At times, the aircraft fluid supply will be restricted due to small return oil lines in the aircraft. If this is a problem, decrease the flow control setting until the cavitation is eliminated.

b. HPU Reservoir Position (Open Loop)

In this position, the HPU reservoir supplies fluid to the pump and accepts return fluid from the aircraft. It is desirable to operate the HPU in this mode since it eliminates any possibility of cavitation.

Since the HPU reservoir is vented to atmosphere and the aircraft is at a higher level, it is normal for the aircraft reservoir to drain into the HPU reservoir. It is, therefore, necessary to be sure that sufficient room is available in the HPU reservoir to accommodate the additional fluid.



CAUTION!

The aircraft system reservoir must be serviced after completion of operational testing.

In the "HPU Reservoir" position, faster landing gear swings are usually possible since there is no restriction to flow at the pump inlet.

5.5.4 Bypass Valve Operation

The bypass valve is used for unloading the pump. The valve should be either in the fully open or fully closed position only. Do not operate the valve in a partially open position.

a. Start Up Operation

The bypass valve must be opened prior to starting the HPU in order to allow the motor to start under a no load condition and not pressurize the aircraft hydraulic system.

b. Shut Down Operation:

Prior to shutdown, the bypass valve must be opened to bleed off any residual system pressure.



CAUTION!

Excessive heat, which could damage machine components, will be generated if the bypass valve is partially open or is used for regulating flow or pressure.

- Use the flow and pressure controls for regulation.
- Use the bypass valve for unloading the system only.

5.5.5 RETURN BACK-PRESSURE VALVE OPERATION

The **backpressure** valve is used for maintaining a preset (adjustable) pressure in the return line from the aircraft. The **backpressure bypass** valve allows fluid to flow directly from the aircraft to the HPU reservoir, bypassing the backpressure valve. The **return line pressure gauge** displays the pressure in the return line from the aircraft (See figure 6.3.4 on page 11). The **backpressure bypass** valve can also be used to slowly relieve the backpressure in the return line.

Return Backpressure Setting:

1. Disconnect electrical power from the HPU.
2. Connect the pressure and return hoses together (matching systems).
3. Open the pressure and return system **ball valves**.
4. Connect electrical power to the HPU.
5. Open the system bypass valve, start the HPU, set the flow to one (5) gpm.
6. With the HPU running, close the **system bypass** valve and the **return bypass** valve.
7. While observing the return line **pressure gauge**, adjust the **return backpressure** valve to the desired pressure by turning the knob clockwise to increase pressure; counterclockwise to decrease pressure.
8. Open the **system bypass** valve.
9. Shut off the HPU.
10. Disconnect electrical power from the HPU.
11. Return the hoses to the original condition.

NOTE: *Once the back pressure valve has been adjusted, it is not necessary to change the setting after each operation.*

5.5.6 RETURN SIGHTGAUGE

The **return sightgauge** is used for monitoring the return fluid from the aircraft. This gauge displays the fluid in return line, allowing a visual check for air in the aircraft hydraulic system (See figure 6.3.4). A light behind the sightgauge is supplied for easy viewing in poor lighting conditions (See figure 6.3.2).

5.6 BLEEDING AIR FROM SYSTEM

Rapid fluctuations of the pressure gauge and flow meter are indications of cavitation or entrapped air in the hydraulic lines and/or components. Air may enter the system when:

- Operating the unit with insufficient oil in the reservoir.
- Changing a component on the aircraft.
- Changing hose connections and/or couplings.

5.6.1 To Easily Purge the Unit of Air

- a. Fill reservoir to recommended level.
- b. Open bypass valve.
- c. Place reservoir selector valve in "Hydraulic Power Unit" position.
- d. Start unit and adjust flow control to maximum position.

NOTE: *If fluid is not flowing, shut off HPU and reference 8.2 No Flow in Trouble Shooting section*

- e. Run unit for five (5) minutes and shut off.
- f. If additional bleeding is required, connect the pressure and return hoses together and open all pressure and return ball valves at the rear of the HPU. Start the HPU and slowly close the bypass valve (system pressure should remain under 200 psi (approximately 14 bar). Allow fluid to flow at full flow for five (5) minutes, then shut the HPU off.

WARNING!



Failure to open the return ball valves will cause hose or valve rupture. Property damage and personal injury can result.

5.7 SPLIT SYSTEM OPERATION

The split system option allows control of fluid flow to aircraft with two hydraulic systems. The systems consist of two sets of hoses and valves located in the pressure and return systems. The valves are mounted on the rear of the hydraulic power unit and are of the 90° ball type. The valves are open when the operating handle is in line with the valve.

Although both systems may be operated simultaneously, usually only one system is required at any one time. If both valve sets are open simultaneously, the pump output will be divided between the two systems. Also, cross flow between aircraft reservoirs may occur if a reservoir level or pressure differential exists. Select valve positions prior to starting machine.

5.7.1 To Operate the Split System

- a. Before starting machine, open pressure and return valves of the same system.



WARNING!

Ensure pressure and return hoses of the same system are paired and used together.

- b. After completing tests on one system, shut the machine off before selecting the second system.



WARNING!

NEVER open or close split system valves without shutting off the Hydraulic Power Unit. Damage to the aircraft system or reservoir may result if either return line valve is closed while the machine is running.

5.8 HAND PUMP OPERATION (Option M)

The Hand Pump Option allows for filling the reservoir (low pressure) or static testing of components or system (high pressure). The hand pump circuit is separate from the main hydraulic system; a separate filter and hose are attached to the back panel of the HPU.

5.8.1 To Operate the Hand Pump

- a. Remove the pump handle from inside the front access door. (Reference **5.3.6 – Hand Pump Controls**)
- b. Insert the end of the pump handle through the front panel opening into the hand pump relief screw.
- c. Turn the pump handle clockwise to close the relief screw.
- d. Insert the pump handle onto the hand pump arm through the front panel slot.
- e. Pump the handle using an up and down motion. Observe the hand pump system pressure on the hydraulic control panel (**Figure 6.3.3 Hydraulic Control Panel**). The pump is an automatic two stage pump. 500 psi (34.47 bar) can be produced with high fluid flow and 5,000 psi (344.74 bar) can be produced with low fluid flow.
- f. Turning the relief screw in a counter-clockwise direction releases hydraulic pressure in the hand pump system.



Pressurized Fluid! Before disconnecting the hand pump pressure hose, ALWAYS open the relief screw valve to relieve any residual pressure in the hydraulic system.

5.9 SAMPLE VALVE

A sample valve is provided on the rear of the unit to obtain a fluid sample for analysis or inspection. In order to obtain a representative fluid sample, it is suggested that ANSI/B93.19M-1972 (R1993) be followed. *Reference Appendix VIII.*



Pressurized Fluid! Before servicing the HPU or equipment, ALWAYS open the bypass valve to relieve any residual pressure in the hydraulic system.

5.10 EMERGENCY SHUT DOWN PROCEDURE

In the event an emergency shut down is necessary, press the emergency stop switch located on the electrical panel. (Reference **5.3.2 – Electrical Control Panel**) Open the bypass valve to remove any system pressure.

5.11 DESCRIPTION OF ALARM SYSTEMS

Reference **5.3.2 – Electrical Control Panel**

5.11.1 High Fluid Temperature Indicator

The indicator light for high fluid temperature is an active light which will illuminate when the return fluid temperature is 160° F (71° C) or above. The HPU will shut down if the light is illuminated. The HPU can be re-started when the fluid has cooled sufficiently and the light has shut off.

If the high temperature light is illuminated reference section **8.0 Trouble Shooting**.

5.11.2 Voltage/Phase Monitor Indicator

The indicator light for the voltage/phase monitor is an active light which will illuminate if there is a problem with the incoming electrical power source. The HPU will shut down if the light is illuminated.

If the voltage/phase monitor light is illuminated, reference section 8.0 Trouble Shooting.

5.11.3 High and Low Reservoir Level Indicator (Option L)

The indicator lights for high and low reservoir level are active lights which will illuminate when the reservoir fluid level is either above the maximum level or below the minimum level. The HPU will shut down if either of the lights are illuminated.

If the light on either of the reservoir level indicator lights, restore the fluid level in the reservoir to a normal operating range.

5.11.4 Clogged Filter Indicator Light

The indicator light for the clogged filter is a passive light which will illuminate if the pressure filter element becomes clogged or is in need of replacement. The HPU will not shut down if the light is illuminated.

If the clogged filter indicator light is illuminated, the pressure filter element requires changing. Reference 9.5.1 Pressure Filter Element) for maintenance procedure. Pressing the clogging filter indicator light will reset the light and the light will turn off.

NOTE: Maintenance and Trouble Shooting are to be performed by a skilled and trained technician.

5.12 INFREQUENT HPU USE

If the unit is not used frequently Tronair recommends operating the unit monthly. Operating regularly assures that the seals are kept lubricated, eliminates air pockets in the system, reduces moisture in the fluid and helps extend the hose life.

5.12.1 Infrequent HPU Use Start Up Procedure

1. Assure that the HPU reservoir is filled between the minimum and maximum level
2. Connect the unit to a proper electrical power source
3. If unit is equipped with a run around kit, connect the pressure and return hoses together
4. Place the reservoir selector valve in "HPU Reservoir" position
5. Open the return ball valves on the back of the unit
6. Pressure ball valves
 - a. If unit **IS** equipped with a runaround kit **ensure the hoses are connected to each other**, open the pressure ball valves on the back of the unit
 - b. If the hoses **are not connected to each other**, close the pressure ball valves on the back of the unit
7. Verify the return ball valves on the back of the unit are open
8. Fully open the bypass valve
9. Adjust the pressure control to the minimum setting (CCW)
10. Start the unit and verify the flow is above "0" on the flowmeter
 - a. If flow is present: adjust the flow control to increase flow (CW)
 - b. If no flow is immediately present: turn unit off, verify the motor rotation (see 3.3 Connecting Electrical Leads), correct rotation if necessary
11. Set flow to ½ the maximum flow capacity of the unit. You may need to increase the pressure adjustment to achieve flow.
12. Bypass valve
 - a. If unit **IS** equipped with a runaround kit **ensure the hoses are connected to each other**, fully close the bypass valve
 - b. If the hoses **are not connected to each other**, leave the bypass valve fully open
13. Operate the unit for 15-30 minutes in this condition. Fluid temperature should reach 100°-130° F (37.8°-54.4° C)
14. At the completion of the 15-30 minute circulation run, open the bypass valve and shut off the unit
15. Remove the electric power
16. Place the selector valve in the Aircraft Reservoir position
17. Close the pressure and return ball valves on the back of the unit

6.0 PACKAGING AND STORAGE

6.1 PACKAGING REQUIREMENTS

- Drain hydraulic fluid until level is below the minimum fluid level indicator.
- Block up the unit on a pallet so the wheels are not touching the pallet or shipping container.
- Plug all hose ends.
- Strap unit to pallet or shipping container using the tie down rings located on the frame bottom.

NOTE: Use at least four (4) straps with a minimum 8,000 lb (3,629 kg) capacity each.

6.2 HANDLING

The unit is designed to be moved by hand using the handles located on the front of the unit. The unit can be lifted by means of a fork truck from the center of the machine. Lifting must be from the motor side of the unit only.

NOTE: Be sure the forks are long enough to reach the frame cross members for stability during lifting. Spread the forks to their maximum width for stability. Reference Figure HPU on Forklift.

6.3 PACKAGING PROTECTION

No special packaging material for cushioning or suspension is required.

6.4 LABELING OF PACKAGING

Packaging should be labeled as follows:

**DO NOT DROP
THIS SIDE UP
DO NOT STACK** ↑

6.5 STORAGE COMPATIBILITY

No special considerations for short term storage (less than three months).

6.6 STORAGE ENVIRONMENT

Cover HPU with a suitable, non-abrasive tarp if storing outside. For storage periods greater than three months, drain hydraulic fluid from all hoses and the reservoir. Cover unit to protect outside surface.

If storing outside, protect unit from freezing water, sand, dirt, and direct sunlight. A cover is highly recommended.

6.7 STORAGE SPACE AND HANDLING FACILITIES

- Weight (Dry): 6,000 lbs (2,722 kg)
- Dimensions: Width 80.3 in (204 cm) Add 6.0 in (15.2 cm) for Split System.
Height 68 in (173 cm)
Depth 105 in (266 cm) Add 11 inches (28 cm) for trailer option

7.0 TRANSPORTATION

- Do not stack Hydraulic Power Units.
- The unit can be lifted by means of a fork truck from the motor side center of the HPU.

NOTE: Be sure the forks are long enough to reach frame cross members for stability during lifting. Spread the forks to their maximum width for stability. Reference figure HPU on Forklift.

- Weight (Dry): 6,000 lbs (2,722 kg) *Estimated*

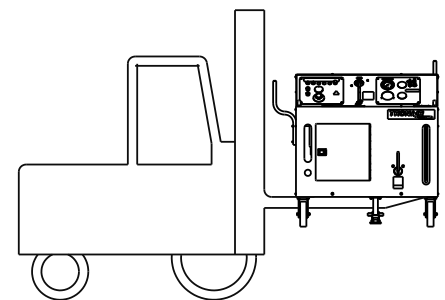

HPU on Forklift

8.0 TROUBLE SHOOTING

The following is a guide to solutions of common problems associated with the HPU. See related Appendices for Hydraulic and Electrical Schematics.

If the problem is not resolved using the trouble shooting information, call the manufacturer for Technical Assistance (See Section **1.3 Manufacturer**).

NOTE: Maintenance and Trouble Shooting are to be performed by a skilled and trained Technician.

8.1 HPU WILL NOT START

Possible Cause	Solution
Supply power off	Check incoming power and restore power. Check across-the-line voltage on all three phase legs
Supply power fuses are blown/ circuit breakers tripped	Check and replace. Check across-the-line voltage on all three phase legs
Control Transformer fuses blown	Check and replace
Supply power phase or voltage incorrect (Phase/Voltage Monitor Option G – J only)	Voltage/Phase Monitor Indicator light will be illuminated Refer to Section 3.3 Connecting Electrical Leads
Reservoir fluid level is too high or too low (Electric Reservoir Level Option L only)	One reservoir level indicator light (Low or High) will be illuminated. Fill the reservoir above the Minimum Fluid Level arrow to extinguish the Low Level light. Drain fluid below the Maximum Fluid Level arrow to extinguish the High Level light
High return fluid temperature (Electric Over-Temperature Option S only)	High Fluid Temperature indicator light will be illuminated. Allow the hydraulic fluid to cool until the light goes out. Refer to Section 8.5 for over-heated causes
Motor has tripped thermal overload device	Allow the motor to cool. The thermal overload device (motor starter) will reset automatically after sufficient cooling. The tripped condition is usually caused by loading the motor beyond its rated capacity; however, any condition (such as unbalanced voltage) that causes an increase in amperage can result in a tripped condition

NOTE: Using the bypass valve to meter flow or pressure will increase the motor load and may cause the thermal overload device to trip. Refer to section 6.5.4 Bypass Valve Operation for proper use of the bypass valve.

8.2 NO FLOW

Possible Cause	Solution
Motor turning in wrong direction	See Section 3.3 Connecting Electrical Leads
Flow control set too low	Increase flow setting
Fluid level in reservoir too low	Service the HPU reservoir
Air in pump inlet lines	Disconnect the HPU from the aircraft. Fill the HPU reservoir to a level above the pump inlet port. Set the reservoir selector valve to the HPU Reservoir position. Fully open the Bypass Valve. Close the Pressure and Return ball valves at the rear of the unit. Adjust the pump flow to maximum and "bump" the start and stop switches to "jog" the motor. Flow should be indicated at the Flowmeter on first or second "jog"

NOTE: Under some conditions where a large amount of air has entered the system, the pump may not be able to draw an initial prime. If this occurs, loosen the inlet hose near the pump and allow air to escape. Re-tighten the hose when fluid appears.

Possible Cause	Solution
Motor is turning but pump is not	Check pump and motor couplings to ensure they are tight
Flow path does not exist	A flow path (such as a moving actuator or an open circuit) must exist for flow to be present. When system pressure exceeds the compensator control setting, or when the system no longer requires flow, the control de-strokes the pump while maintaining the preset pressure

8.3 REDUCED FLOW

Possible Cause	Solution
Flow control set too low	Increase flow setting.
Pressure adjustment is set too low	Slightly increase pressure setting.
Pressure compensator control is reducing pump output	When system pressure exceeds the compensator control setting, or when the system no longer requires flow, the control de-strokes the pump while maintaining the preset pressure.
Pump inlet is not receiving enough fluid (cavitation)	Follow the procedure for "Air in pump inlet lines" in Section 8.2.
Motor is "Single Phasing"	Motor is not getting power on all three phase legs. Check across-the-line voltage on all three phase legs.
Supply voltage is 50 Hz	Pumps used on 50 Hz units will flow at only 83% of the pump nameplate rating. An HPU designed to run on 50 Hz will supply flow as stated in the specifications for that unit.

8.4 NO PRESSURE or REDUCED PRESSURE

Possible Cause	Solution
Pressure adjustment is set too low	Increase pressure adjustment.
Motor is "Single Phasing"	Motor is not getting power on all three phase legs. Check across-the-line voltage on all three phase legs.
Pump inlet is not receiving enough fluid (cavitation)	Follow the procedure for "Air in pump inlet lines" in Section 8.2.
Flow path is open	Pressure is resistance to flow. The HPU will reach full pressure as flow paths (such as moving actuators and open valves) are closed.

8.5 FLUID OVERHEATS

Possible Cause	Solution
Fan is not functioning properly	Check the cooler fan output. Forced air should be easily detected at the right hand side of the HPU. Check the fuses for the fan motor (See Appendices – Electrical Schematic INS-2016).
Bypass valve or rear ball valve is being used in a partially closed position	The bypass valve and all ball valves must be used in a fully open or fully closed position. These valves are not intended for metering flow. All flow adjustments must be made using the pump flow control.

8.6 HAND PUMP (*Option M*) IS NOT PUMPING FLUID

Possible Cause	Solution
Release screw is open	Use the slotted end of the pump handle to close the release screw located at the base of the pump.
Ball valve is closed	Open the ball valve for the pump inlet line located at the bottom of the reservoir.
Pump piston is filled with air	If the pump is not primed after several strokes, remove the bleed screw from the top of the pump piston (See Section 9.13.9.a – <i>Pump Diagram</i>). Slowly stroke the pump until fluid is present at the bleed screw. Replace the bleed screw.

9.0 MAINTENANCE

If the unit is not used frequently Tronair recommends operating the unit monthly. Operating regularly assures that the seals are kept lubricated, eliminates air pockets in the system, reduces moisture in the fluid and helps extend the hose life. If the unit is not used frequently see 5.12 Infrequent Use Procedure.

9.1 GENERAL

Periodically inspect the HPU for loose fasteners, hose fittings, damaged hoses, and worn electrical cables. Make repairs as needed for safe operation.

Reference Sections **9.2 – 9.15** for Parts Lists, Descriptions and Illustrations.

9.2 ELECTRIC MOTOR

The Electric Motor is pre-greased by the manufacturer. Periodic greasing is necessary on a frequently used HPU. **Reference Appendix – Lincoln Motor Manual** for details.

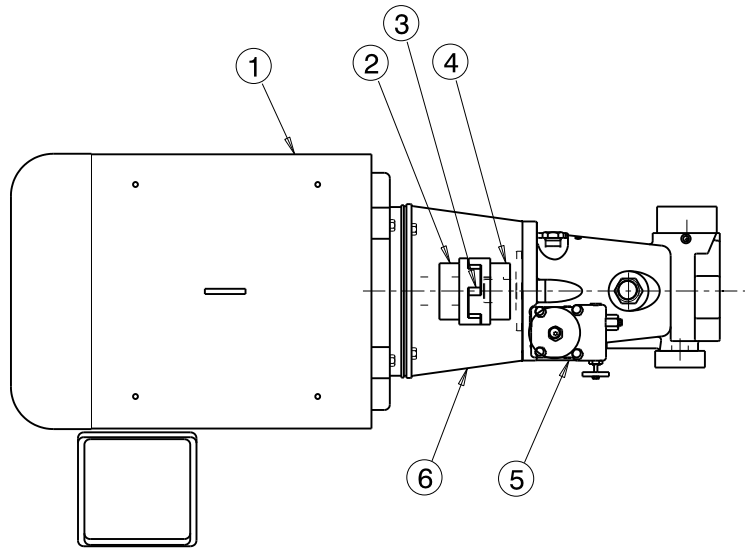

Parts List

Item	Part Number	Description	Qty
1	Reference table below	Electric Motor	1
2	H-2552-30	Coupling (Motor Half)	1
3	H-2551	Spider (Hytrel)	1
4	H-3245	Coupling (Pump Half)	1
5	Reference 10.3 and 10.3.1	Motor Driven Hydraulic Pump	1
6	HC-1427-08	Pump/Motor Adapter	1

60 Hz Applications	
Voltage	Part Number
380	EC-1224-17
460	EC-1224-17
575	EC-1224-18

50 Hz Applications	
Voltage	Part Number
380	EC-1224-17
415	EC-1224-17
440	EC-1224-17

9.3 MOTOR DRIVEN HYDRAULIC PUMP

The hydraulic pump does not require regular maintenance. Under normal operating conditions, the pump will perform for thousands of hours of use without rebuilding. See **Appendix VI – Denison PV Series Pumps** for further details.

9.3.1 Motor Driven Hydraulic Pump Replacement Parts

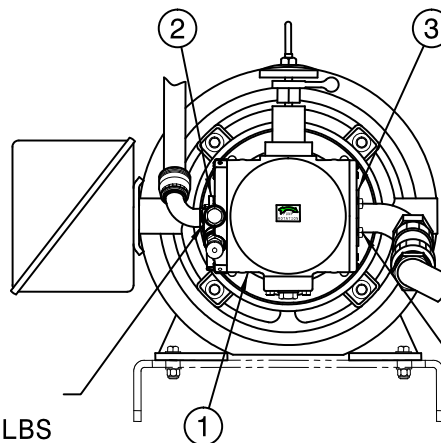

TORQUE FLANGE BOLTS ON
PRESSURE SIDE TO 69 FT LBS

TORQUE FLANGE BOLTS ON
INLET SIDE TO 85 FT LBS

Parts List

Fluid Type: Aviation Phosphate Ester, Type IV

Item	Part Number	Description	Qty
1	◆ HC-2720-01	Assembly, Hydraulic Pump	1
2	HC-2664-03-S-E	Kit, Flange (<i>Pressure Side</i>)	1
3	N-2674-07	Kit, Flange (<i>Inlet Side</i>)	1
<i>Not Shown</i>	N-2007-29-S-E	Fitting, Connector (<i>Case Drain Port</i>)	1
<i>Not Shown</i>	N-2924	Connector, in-line Orifice	1

◆ Refer to section 9.14 for listing of Replacement Labels.

9.3.2 Motor Driven Hydraulic Pump Replacement Kits List

Fluid Type: Aviation Phosphate Ester, Type IV, V

Part Number	Description
*	Kit, Shaft and Bearing Assembly
*	Kit, Shaft Seal

* Call Tronair for Details

9.4 HYDRAULIC FLUID

Any time an unusual color, smell or visual indicator is noticed with the hydraulic fluid, a sample analysis should be performed to determine the condition of the fluid. (See **6.9 – Sample Valve Operation**)

Refer to the manufacturer of the specific fluid for your unit to obtain additional information:

Model Number: 5833

Fluid Type: Aviation Phosphate Ester, Type IV

9.5 FILTERS

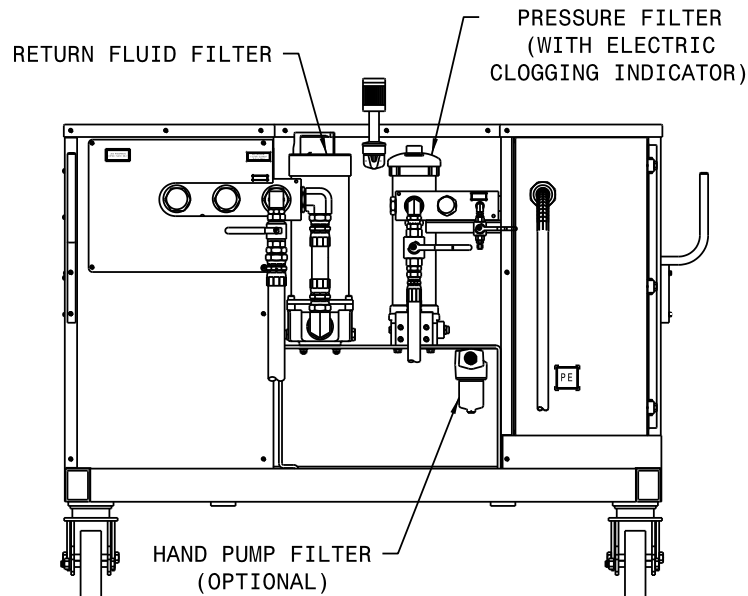

9.5.1 Pressure Filter Element

Replace the filter element any time the clogged filter indicator light is triggered.
Replace the filter element annually to ensure proper cleanliness of the hydraulic system. This is a minimum requirement.

Standard filter changes depend on how frequently the HPU is used and the cleanliness of the fluid, along with the environment to which the HPU is exposed. Periodic fluid analysis is recommended to properly determine the optimum frequency of filter element changes.

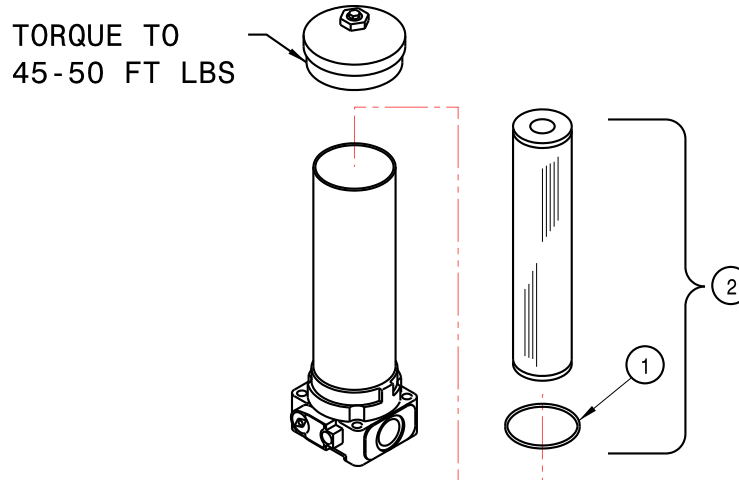

Parts List

Fluid Type: Aviation Phosphate Ester, Type IV

Item	Part Number	Description	Qty
1	HC-2006-246	O-ring	1
2	K-3588	Kit, Filter Element	1

9.5.2 Return Filter Element

Replace the return filter element at the same time the pressure filter element is being replaced.

TO ACCESS FILTER ELEMENT,
REMOVE TOP OF FILTER
BODY. HANDLE TORQUE
IS TO BE HAND TIGHT.

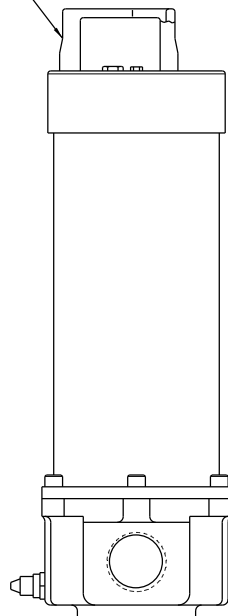

Parts List

Fluid Type: Aviation Phosphate Ester, Type IV

Item	Part Number	Description	Qty
Not Shown	HC-2006-257	O-ring	1
Not Shown	◆ K-3587	Kit, Replacement Filter Element	1

◆ **HC-2006-257 O-ring is included in Kit.**

9.5.3 Hand Pump (*Option M*) Filter Element

Replacement of the hand pump filter element is dictated by frequency of use and the cleanliness of the fluid, along with the environment to which the HPU is exposed. Changing the hand pump filter element at the same time as the pressure filter element will ensure a regular maintenance schedule.

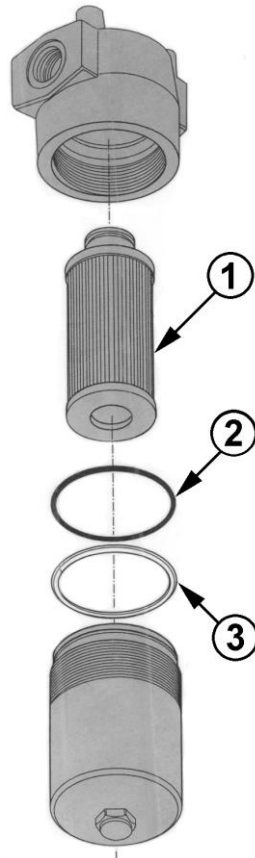

Parts List

Fluid Type: Aviation Phosphate Ester, Type IV

Item	Part Number	Description	Qty
2 & 3	K-3797	O-ring and Backup Ring	1
1 - 3	K-3752	Kit, Replacement Filter Element	1

9.5.4 Desiccant Air Filter

Replace the desiccant/air filter whenever the material inside the element is pink or reddish in color (see Element Label for details).

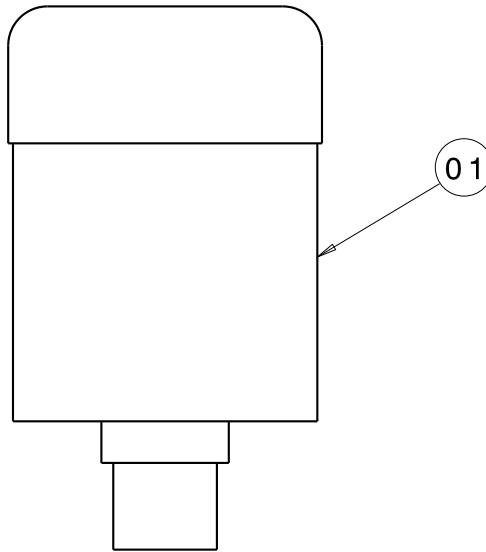

Parts List

Fluid Type: Aviation Phosphate Ester, Type IV

Item	Part Number	Description	Qty
1	HC-1763	Filter Element	1

9.5.5 Pressure Filter Assembly with Electric Filter Clogging Indicator

The Electric Filter Clogging Indicator does not require regular general maintenance. The panel light will illuminate when the clogging indicator senses a 50 psi differential pressure across the filter element. Installing a new filter element will eliminate the clogged condition. Pushing the illuminated button will reset the indicator light.

NOTE: Higher flow rates will result in higher differential pressures. (Example: The clogging indicator may sense a 50 psi differential pressure at a flow rate of 34 gpm but not show a clogged condition when the flow rate is reduced to 10 gpm.)

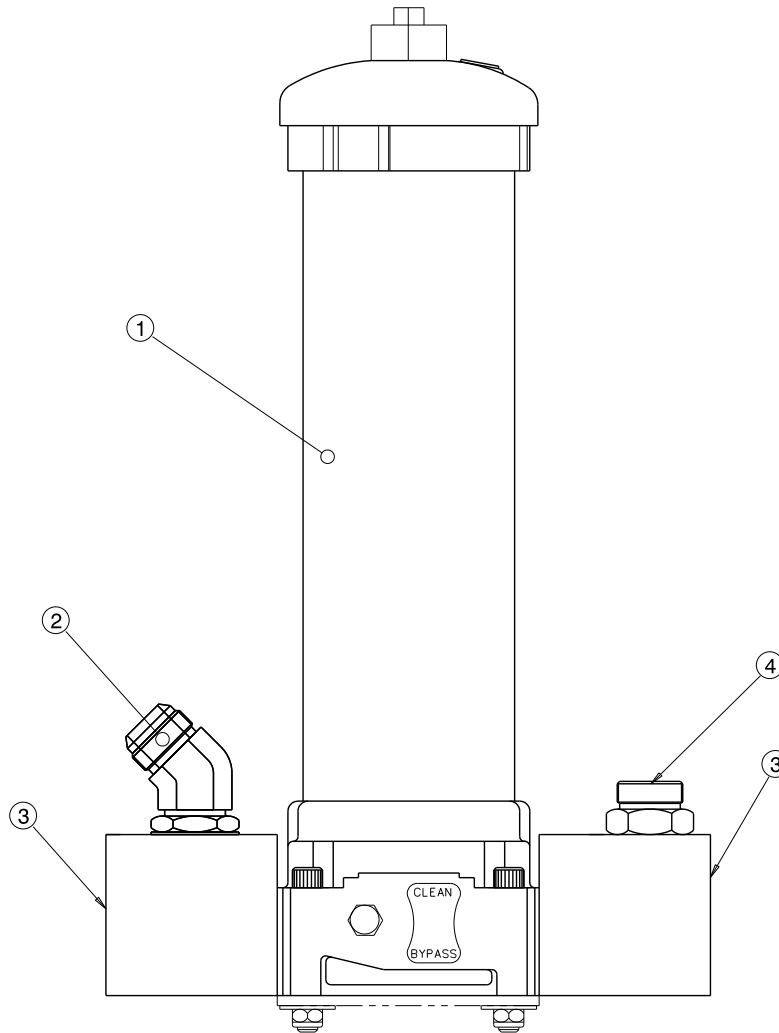

Parts List

Fluid Type: Aviation Phosphate Ester, Type IV

Item	Part Number	Description	Qty
1	HC-2053	Filter, Pressure (Phosphate Ester)	1
2	N-2974-S-E	Elbow, 45° Straight Thread	1
3	HC-2106	Flange, Elbow	1
4	N-2507-25-S-E	Connector, Male Ferulok	1

- 9.5 FILTERS (continued)
- 9.5.6 Return Filter Assembly

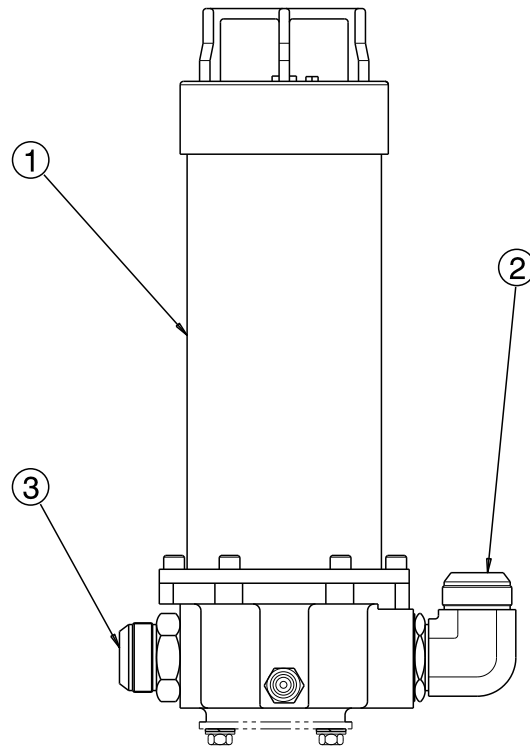

Parts List

Fluid Type: Aviation Phosphate Ester, Type IV

Item	Part Number	Description	Qty
1	HC-2052	Filter, Return (Phosphate Ester)	1
2	N-2001-33-S-E	Elbow, Straight Thread	1
3	N-2007-33-S-E	Connector, #32 Straight Thread	1

9.6 HYDRAULIC HOSES

Hoses used on the HPU must be periodically inspected for damage, blisters, leaks, or hose end problems. Any damaged or defective hose should be replaced as soon as possible.

Hoses used on Aviation Phosphate Ester, Type IV units have a shorter useful life than hoses used on Mineral Base units. Surface moisture is normal with Aviation Phosphate Ester, Type IV hoses as long as the fluid does not form into drops.

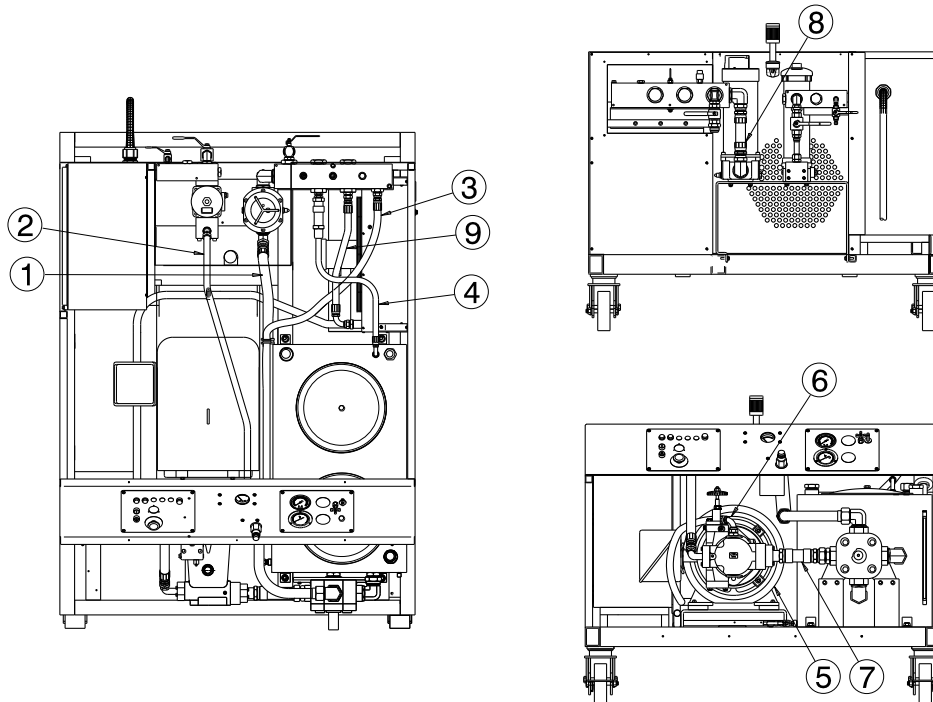

Parts List

Fluid Type: Aviation Phosphate Ester, Type IV

Item	Part Number	Description	Qty
1	TF-1041-18*59.0	Assembly, Hose #32	1
2	TF-1117-37-57.5	Assembly, Hose #16	1
3	TF-1041-04*70.5	Assembly, Hose #24	1
4	TF-1041-16*37.5	Assembly, Hose #16	1
5	TF-1117-37-98.0	Assembly, Hose #20	1
6	TF-1041-32*110	Assembly, Hose #20	1
7	TF-1196-11-12.5	Assembly, Hose #32	1
8	TF-1041-18*11.7	Assembly, Hose #32	1
9	TF-1041-54*29.0	Assembly, Hose #20	1
N/S	TF-1040-05*300	External Pressure Hose	1
N/S	TF-1041-04*300	External Return Hose	1

9.7 INSTRUMENT PANEL

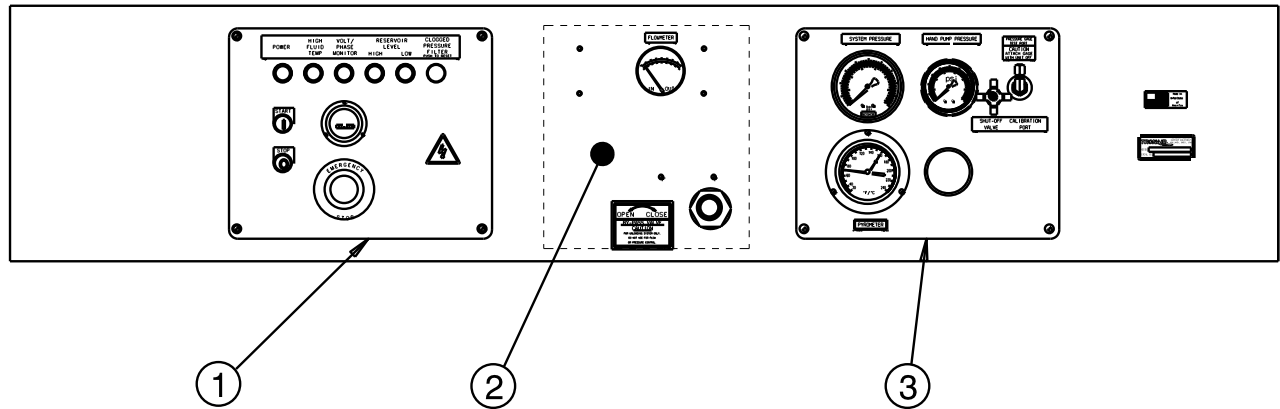

Parts List

Fluid Type: Aviation Phosphate Ester, Type IV

Item	Part Number	Description	Qty
1	See Section 9.7.1	Electric Panel	1
2	See Section 9.7.3	Assembly, Control Block	1
3	See Section 9.7.2	Hydraulic Panel	1

9.7.1 Electric Panel

The Electric Panel does not require regular general maintenance.

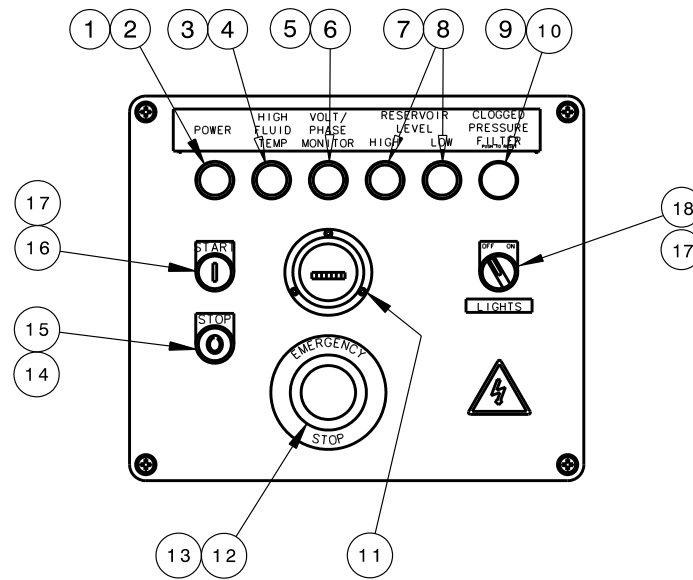

Parts List

Fluid Type: Aviation Phosphate Ester, Type IV

Item	Component	Part Number	Description	Qty
1	Standard	EC-1945-01	Light, Diffused Pilot	1
2	Standard	EC-1951-MN5G	Power, Module w/Latch	1
3	Option	EC-1945-03	Light, Diffused Pilot	1
4	Option	EC-1951-MN5Y	Power, Module w/Latch	1
5	Option	EC-1945-03	Light, Diffused Pilot	1
6	Option	EC-1951-MN5Y	Power, Module w/Latch	1
7	Option	EC-1945-04	Light, Diffused Pilot	2
8	Option	EC-1951-MN5B	Power, Module w/Latch	2
9	Option	EC-1952	Push Button, Illuminated/Flush	1
10	Option	EC-1944	Power, Module w/Contact/Latch	1
11	Option	EC-1577	Hour Meter (50 Hz Operation)	1
		EC-1578	Hour Meter (60 Hz Operation)	1
12	Option	EC-1948	Switch, Emergency Stop	1
13	Standard	EC-1946-MX02	Contact Block w/Latch	1
14	Standard	EC-1953-ME205	Push Button, Non-Illuminated	1
15	Standard	EC-1946-MX01	Contact Block w/Latch	1
16	Standard	EC-1953-MF306	Push Button, Non-Illuminated	1
17	Standard	EC-1946-MX10	Contact Block w/Latch1	1
18	Special	EC-1947	Switch, Selector Non-Illuminated	1
N/S	Special	EC-1767	Light Base	6
N/S	Special	EC-1825	Light Bulb	6
N/S	Special	SC-1776	Light Shield	6

9.7.2 Hydraulic Panel

Annual calibration of instrumentation is recommended. See Section **11.0 – Calibration of Instrumentation** for details of calibration.

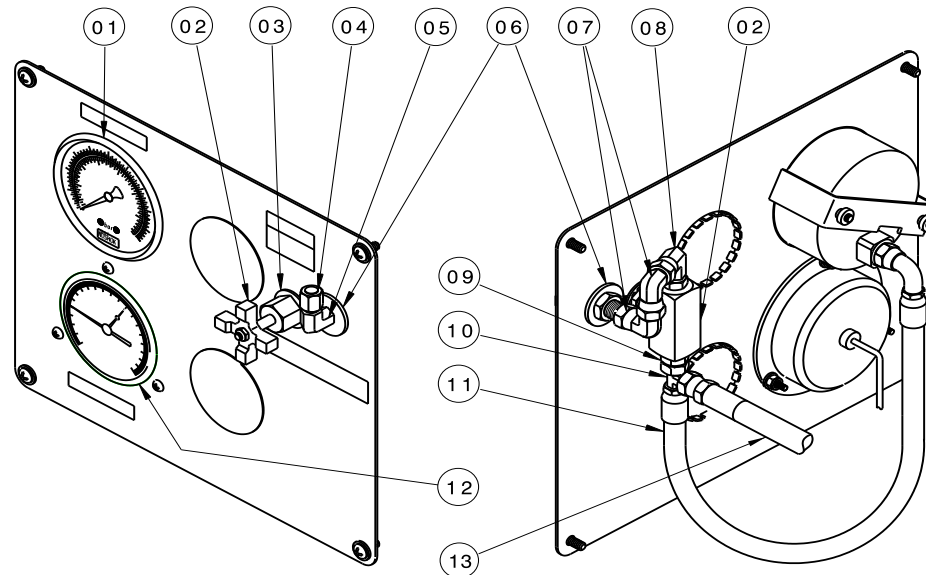

Parts List

Fluid Type: Aviation Phosphate Ester, Type IV

Item	Part Number	Description	Qty
1	HC-2144	Gauge, Pressure	1
2	HC-1900-02	Valve, Needle	1
3	HC-1122	Kit, Panel Mounting	1
4	N-2008-03-S	Cap, ¾ JIC	1
5	N-2022-03-S	Elbow, Bulkhead Union #4	1
6	G-1250-1080W	Flatwasher, 7/16 Wide	1
7	N-2002-03-S	Elbow, 90° Swivel Nut #4	2
8	N-2049-07-S-E	Elbow, 90° Swivel 6-4	1
9	N-2007-03-S-E	Connector, Straight Thread	1
10	N-2016-03-S	Tee, Swivel Nut Run #4	1
11	TF-1040-42*24.0	Assembly, Hose	1
12	HC-2268-02	Gauge, Pyrometer	1
13	TF-1040-42*32.0	Assembly, Hose	1

9.7.3 Control Block Assembly

The Control Block Assembly components do not require regular general maintenance.

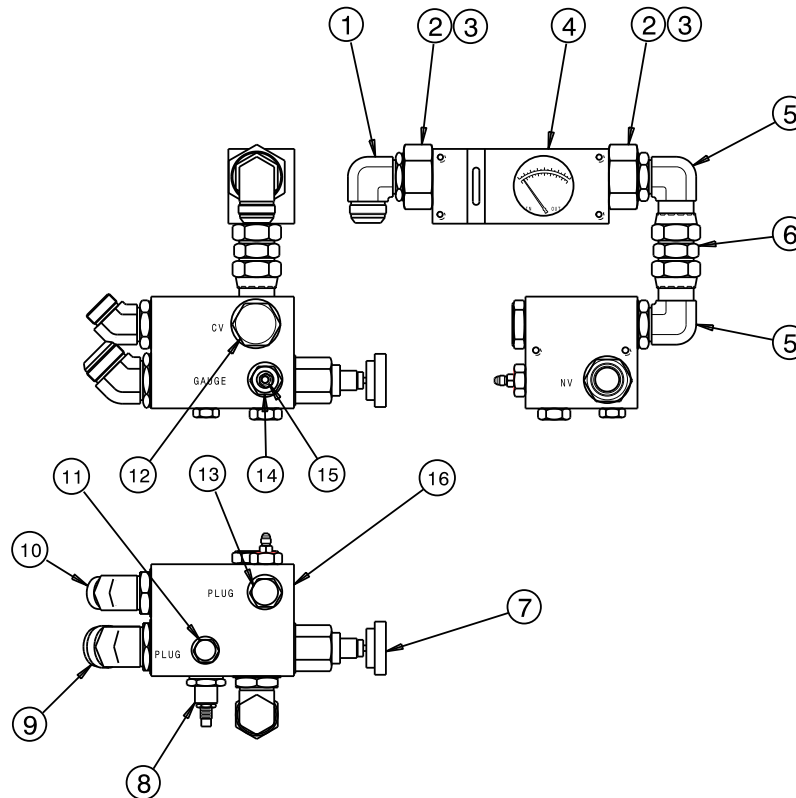

Parts List

Fluid Type: Aviation Phosphate Ester, Type IV

Item	Part Number	Description	Qty
1	N-2973-S-E	Elbow, Straight Thread	1
2	N-2676	Reducer, Straight Thread Modified	2
3	HC-2013-924	O-ring, Series 3	2
4	HC-2075-A1	Flowmeter (Calibrated)	1
5	N-2634-07-S-E	Elbow, 90° Swivel, ORFS Tube End (-20)	2
6	N-2665-13-S-E	ORFS Tube End (-20)	1
7	HC-2214	Valve, Needle (<i>Phosphate Ester</i>)	1
8	HC-1772	Valve, Relief Cartridge	1
9	N-2042-14-S-E	Elbow, 45° Straight Thread (-24)	1
10	N-2974-S-E	Elbow, Male 45°	1
11	N-2053-07-S-E	Plug, O-ring Hex Head (-10)	1
12	HC-2103	Valve, Check	1
13	N-2053-08-S-E	Plug, O-ring Hex Head (-12)	1
14	N-2463-34-S-E	Fitting, Reducer/Expander (12-4)	1
15	N-2007-03-S-E	Connector, Straight Thread (-04)	1
16	J-3331	Manifold, Pressure	1

9.7.3.a System Pressure Relief Valve

The System Pressure Relief Valve does not require regular general maintenance. It is possible however, for a contaminant to hold the relief valve in a partially open condition. If service is required, the new or repaired relief valve must be reset to 4,250 psig.

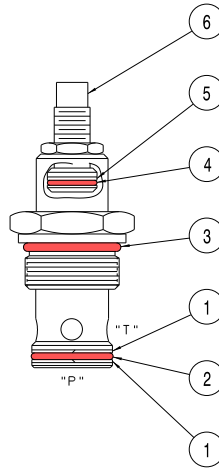

Parts List

Fluid Type: Aviation Phosphate Ester, Type IV

Item	Part Number	Description	Qty
1	HC-2037	Ring, Backup	2
2	HC-2006-119	O-ring, Series 2 (EPR)	1
3	HC-2013-916	O-ring, Series 3 (EPR)	1
4	HC-2006-015	O-ring, Series 2 (EPR)	1
5	HC-2020-015	Ring, Backup	1
◆ 6	HC-1772	Valve, Pressure Relief (<i>Phosphate Ester</i>) Not Set	1

◆ *Item 6 consists of Items 1 – 5.*

9.7.3.b Check Valve

The Check Valve does not require regular general maintenance.

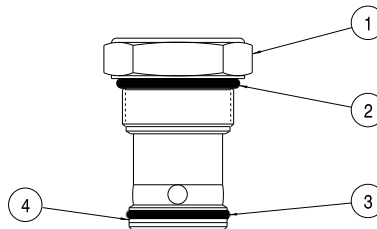

Parts List

Fluid Type: Aviation Phosphate Ester, Type IV

Item	Part Number	Description	Qty
◆ 1	HC-2103	Check Valve (<i>Phosphate Ester</i>)	1
2	HC-2013-920	O-ring, Series 3	1
3	HC-2006-124	O-ring, Series 2	1
4	HC-2020-124	Backup Ring	1

◆ *Item 1 consists of Items 2 – 4.*

9.7.3.c Bypass Valve

The Bypass Valve does not require regular general maintenance.

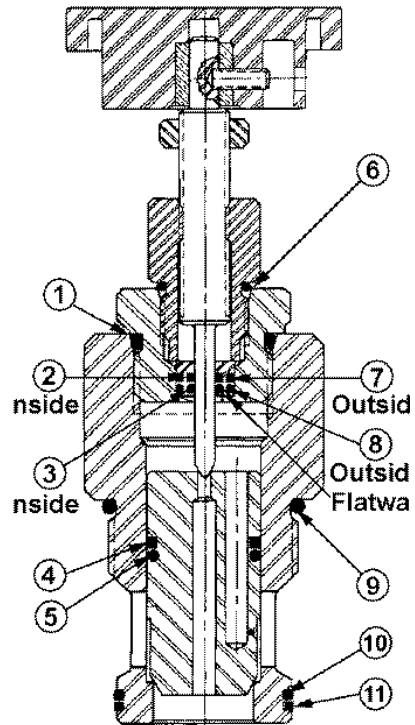

Parts List

Fluid Type: Aviation Phosphate Ester, Type IV

Item	Part Number	Description	Qty
1	HC-2013-914	O-ring, Series 3	1
2	HC-2020-008	Ring, Backup (Teflon)	1
3	HC-2006-008	O-ring, Series 3	1
4	HC-2020-019	Ring, Backup (Teflon)	1
5	HC-2006-019	O-ring, Series 2	1
6	HC-2013-908	O-ring, Series 3	1
7	HC-2020-012	Ring, Backup (Teflon)	1
8	HC-2006-012	O-ring, Series 2	1
9	HC-2013-920	O-ring, Series 3	1
10	HC-2006-028	O-ring, Series 2	1
11	HC-2020-028	Ring, Backup (Teflon)	1
◆12	HC-2214	Valve, Needle (<i>Phosphate Ester</i>)	1

◆ **Item 12 consists of Items 1 – 11.**

9.7.4 Pump Flow Control

The Pump Flow Control does not require regular general maintenance

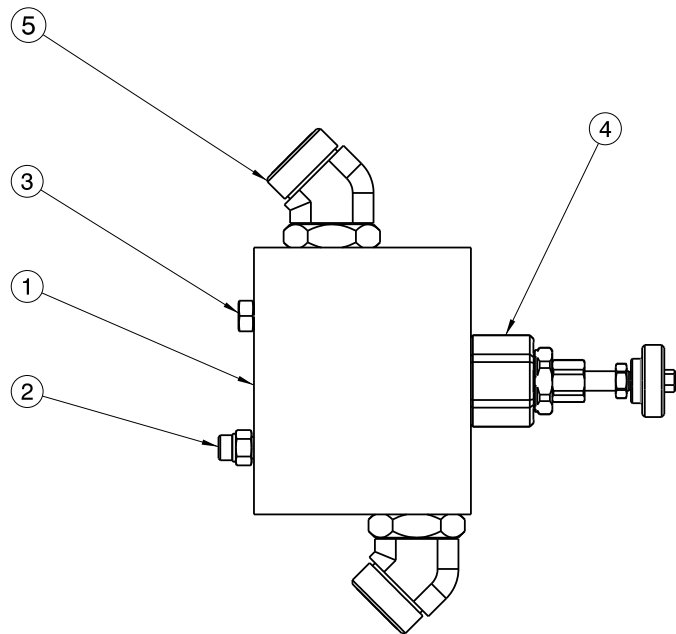

Parts List

Fluid Type: Aviation Phosphate Ester, Type IV, V

Item	Part Number	Description	Qty
1	J-5799	MAINFOLD	1
2	N-2007-08-S-E	CONNECTOR, STRAIGHT THREAD	1
3	N-2053-05-S-E	PLUG, HEX HEAD WITH O-RING	1
4	HC-2214	VALVE, NEEDLE (PE)	1
5	N-2633-18-S-E	ELBOW, 45° ORFS	2

This page left blank intentionally.

9.8 RESERVOIR ASSEMBLY

Replace the desiccant air filter whenever the material inside the element is pink or reddish in color (See Element label for details). The Reservoir Assembly does not require regular general maintenance. If periodic inspections for silt are desired, be certain to thoroughly clean the dome cover and surrounding area before removing the dome cover.

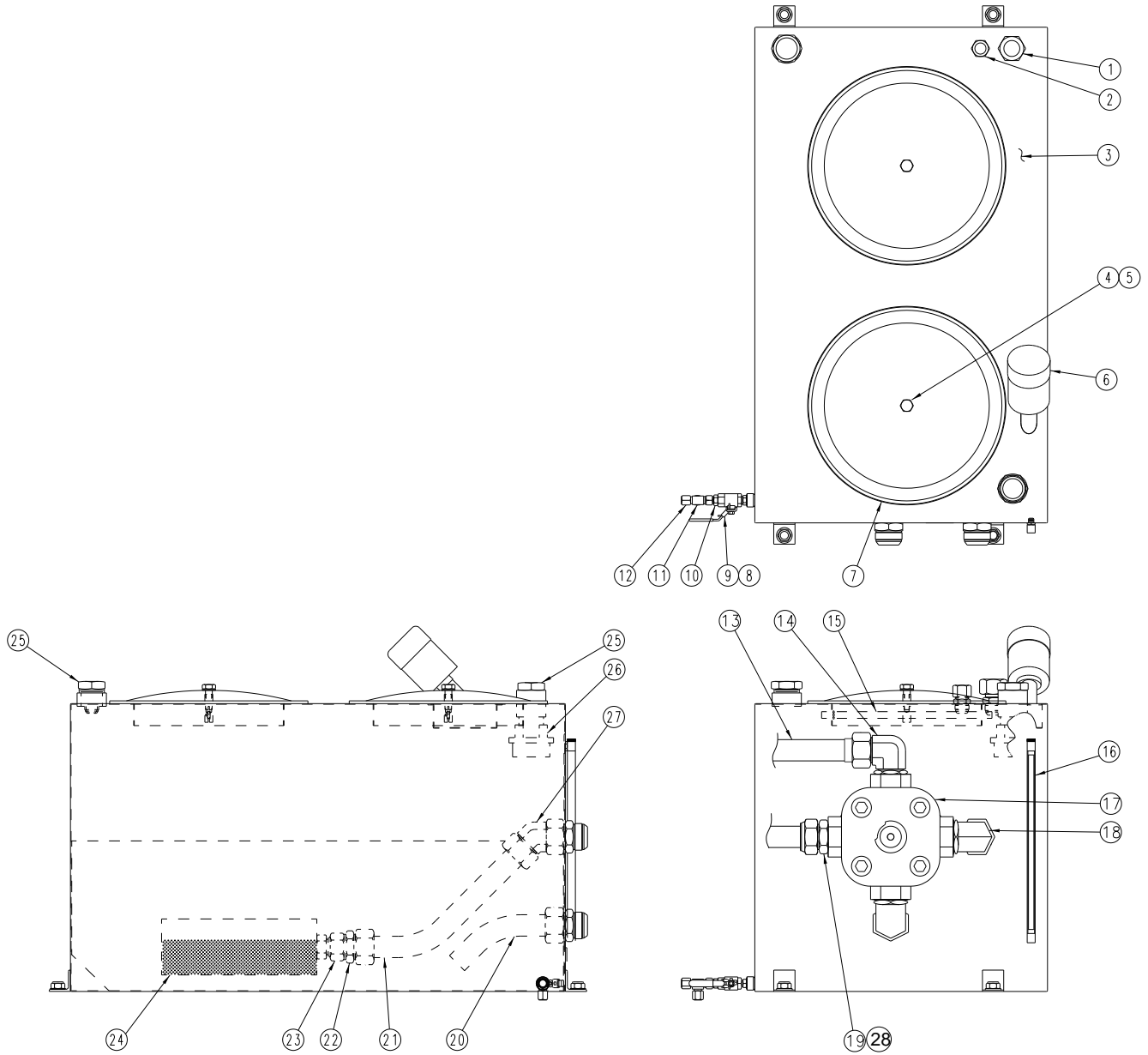

9.8 RESERVOIR ASSEMBLY (continued)

Parts List

Fluid Type: Aviation Phosphate Ester, Type IV

Item	Part Number	Description	Qty
1	N-2008-12-S	Cap, #24	1
2	N-2008-10-S	Cap, #16	1
3	H-2553	Reservoir, 150 gallon (567.8 lt) Stainless Steel	1
4	H-1735-02	Washer, Nylon	2
5	G-1100-110024	Bolt, Hex Head, Grade 5, 5/8 -11 x 2 1/2" long	2
6	HC-1763	Filter, Desiccant	1
7	H-2562	Assembly, Cover	2
8	HC-2013-908	O-ring, Series 3	1
9	HC-1761	Valve, Ball, SAE #8 Lockable	1
10	N-2007-11-S-E	Connector, Straight Thread #8 SAE x #8 JIC	1
11	N-2016-06-S	Tee, Swivel Run, #8 JIC	1
12	N-2008-06-S	Cap, #8	2
13	Z-5803	Assembly, Return Tube	1
14	N-2001-33-S-E	Elbow, Straight Thread	1
15	Z-5338	Assembly, Clamp	1
16	HC-1383-18	Gauge, Sight	1
17	HC-2198	Valve, Selector	1
18	N-2049-32-S-E	Elbow, 90° Swivel, #32 SAE	2
19	N-2007-33-S-E	Connector, Straight Thread	1
20	Z-5802	Assembly, Hydraulic Tube	1
21	Z-5801	Assembly, Hydraulic Tube	1
22	N-2009-30-S	Connector, Male	1
23	N-2210-31-S	Reducer, Pipe Thread	1
24	HC-1397-07	Diffuser, 3" NPT	1
25	N-2206-09-S	Plug, Hex Head, 2" NPT	2
26	HC-1542	Strainer, Nipple Style	1
27	N-2081-11-S	Elbow, 45° Swivel Nut	1
28	N-3011	Anchor, Flange	1

9.9 PRESSURE MANIFOLD ASSEMBLY

The Pressure Manifold does not require regular general maintenance other than ensuring fitting connections remain tight and leak free.

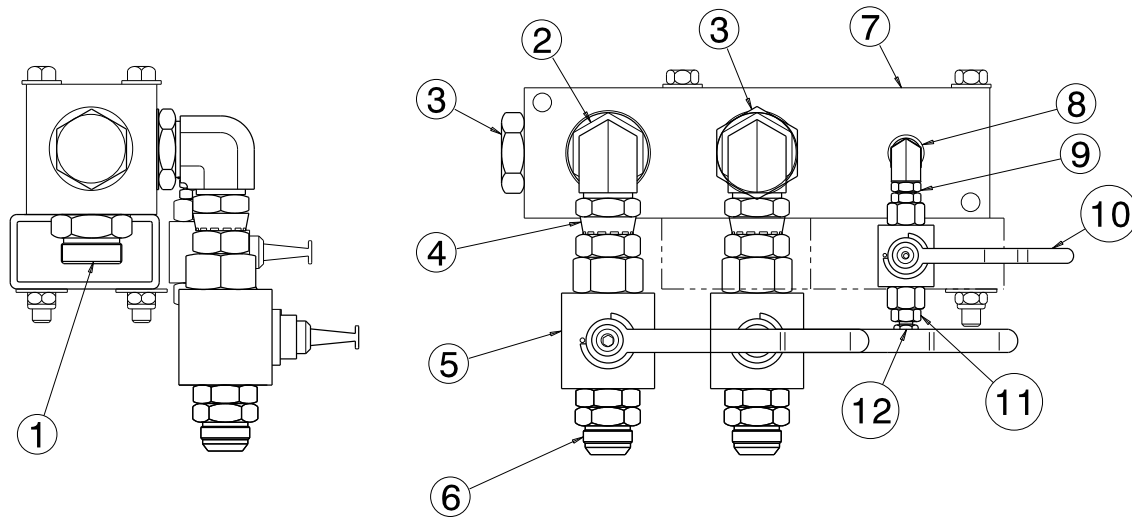

Parts List

Fluid Type: Aviation Phosphate Ester, Type IV

Item	Part Number	Description	Qty
1	N-2507-25-S-E	Connector, Straight Thread (-20)	1
2	N-2630-20-S-E	Elbow, 90° ORFS	2
3	N-2053-11-S-E	Plug, O-ring Hex Head	2
4	N-2650-06-S-E	Connector, ORFS Swivel	2
5	HC-1771-05	Valve, Ball (<i>Phosphate Ester</i>)	2
6	N-2975-S-E	Connector, Straight Thread	2
7	HC-2054	Manifold, Pressure	1
8	N-2661-02-S-E	Elbow, Straight Thread	1
9	N-2464-05-S-E	Union, Straight Thread	1
10	HC-1771-02	Valve, Ball (<i>Phosphate Ester</i>)	1
11	N-2007-05-S-E	Connector, Straight Thread	1
12	N-2008-03-S	Cap	1

9.10 RETURN MANIFOLD ASSEMBLY

The Return Manifold does not require regular general maintenance.

NOTE: DO NOT attempt to adjust the Return System Pressure Relief Valve. See Section 9.9.1 – Return System Pressure Relief Valve for details.

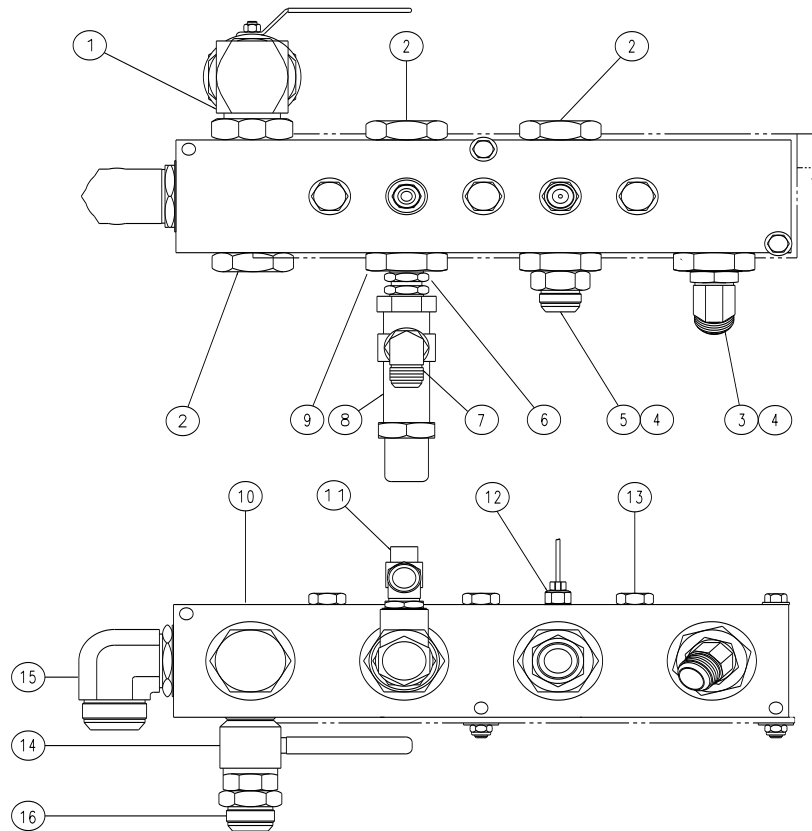

Parts List

Fluid Type: Aviation Phosphate Ester, Type IV

Item	Part Number	Description	Qty
1	N-2666-09-S-E	Elbow, Straight Thread	1
2	N-2053-13-S-E	Plug, O-ring Hex Head	3
3	N-2042-14-S-E	Connector, Straight Thread	1
4	N-2463-28-S-E	Fitting, Reducer/Expander	2
5	N-2007-30-S-E	Connector, Straight Thread	1
6	N-2464-26-S-E	Union, Straight Thread	1
7	N-2001-24-S-E	Elbow, Straight Thread	1
8	HC-2202	Valve, Pressure Relief (<i>Phosphate Ester</i>)	1
9	N-2463-26-S-E	Fitting, Reducer/Expander	1
10	HC-2049	Manifold, Return	1
11	EC-1782-02	Switch, Temperature (<i>Optional</i>)	1
12	HC-2268-02	Gauge, Pyrometer (<i>Optional</i>)	1
13	N-2053-08-S-E	Plug, O-ring Hex Head	3
14	HC-2058-03	Valve, Ball	1
15	N-2001-33-S-E	Elbow, Straight Thread	1
16	N-2007-32-5-E	Connector, Straight Thread	1

9.10.1 Return System Pressure Relief Valve

The Return System Pressure Relief Valve can be purchased as a preset assembly. If the relief valve is serviced by the end user, the valve must be set to crack at 150+/-7 psig **before** being re-installed on the HPU.

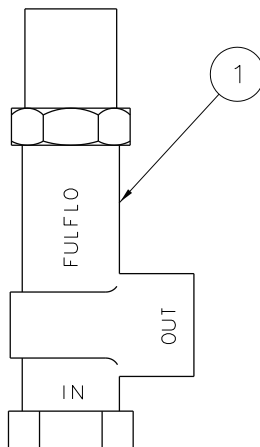

Parts List

Fluid Type: Aviation Phosphate Ester, Type IV

Item	Part Number	Description	Qty
1	HC-2202	Valve, Pressure Relief (<i>Pre-set</i>)	1
<i>Not Shown</i>	◆ HC-2006-220	O-ring, Series 2	1

◆ *Included with Item 1.*

This page left blank intentionally.

9.11 ELECTRICAL COMPONENTS

Regularly inspect the external power cord for nicks, cuts, abrasion, and fluid damage. Replace power cord if damage is found. Reference **9.0 Provision of Spares** for recommended spare fuses.

Reference following page for component descriptions.

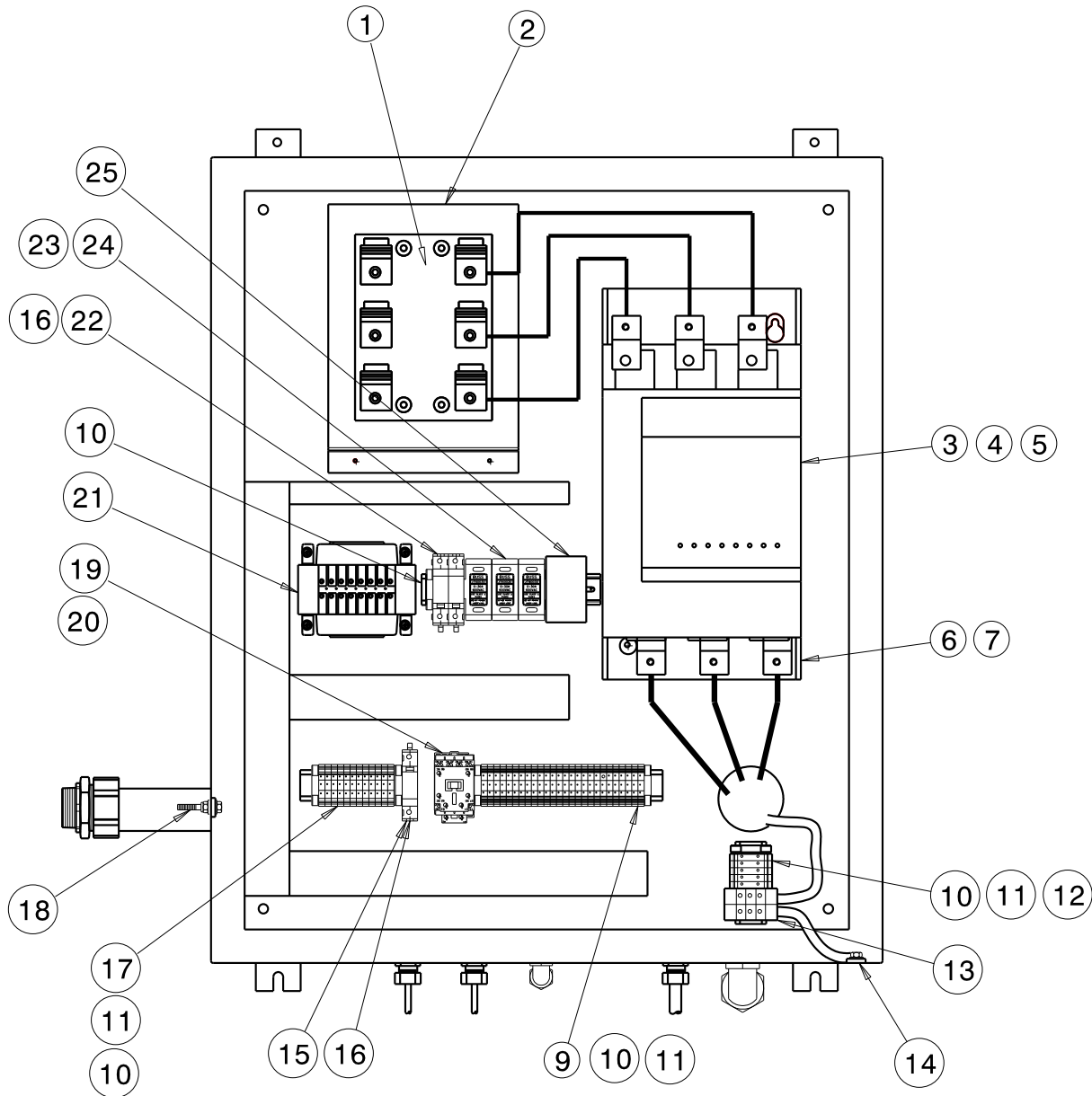

100 HP ASSEMBLY

NOTE: Set Item 6 to Automatic Reset position. Set "A2" to its corresponding full load amps listed in 5.2.4 Motor Power Requirements. Wire per Electrical Schematic INS-1608. Reference Wire Diagram INS-1661.

9.11 ELECTRICAL COMPONENTS *(continued)*

Parts List

Fluid Type: Aviation Phosphate Ester, Type IV

Item	Part Number	Description	Qty
2	EC-1560	Fuse Block, Class J	1
4	EC-1724	Kit, Terminal Lug	2
5	EC-1746	Kit, Terminal Cover	1
6	EC-1564	Relay, Overload	1
7	EC-1603	Shield, Anti-Tamper	1
9	EC-1956-02	Block, IEC Terminal Red	26
10	EC-1959	Anchor, IEC, End	7
11	EC-1960-01	Barrier, End	3
12	EC-1958	Block, IEC Ground	5
13	EC-1957	Block, IEC Ground	2
14	EC-1532-04	Lug, Ground	2
15	EC-1542-14	Fuse, LP-CC Low Peak 1-6/10 A (<i>Secondary</i>)	1
16	EC-1541-01	Fuse Holder, IEC Class CC	Ref
17	EC-1956-03	Block, IEC Terminal, Blue	12
18	EC-1432-04	Lug, Ground	1
19	EC-1591-04	Latch, Mechanical	1
20	EC-1564	Relay, Control	1
21	EC-1804-04	Transformer, Control (200 W)	1
23	EC-1596-01	Fuse Holder, Class J	3
24	EC-1557-01	Fuse, Class J (Heat Exchanger)	3
26	EC-1675-12	Fuse, KTK-R 2 amp (<i>Optional</i>)	Ref
27	EC-1227-05*0600	Power Cord (<i>Not Shown</i>)	1

THE FOLLOWING PARTS ARE APPLICATION SPECIFIC

Be sure to locate the correct voltage and hertz of the unit before selecting the part

Item	60 Hz Applications			Description	Qty
	380	460	575		
1	EC-1556-08	EC-1556-07	EC-1556-06	Fuse, Class J	3
3	EC-1974	EC-1974	EC-2022	Controller, Softstart Motor	1
22	EC-1726-14	EC-1726-11	EC-1726-08	Fuse, Class CC (<i>Primary</i>)	2
23	EC-1596-01	EC-1596-01	EC-1596-01	Fuse Holder, Class J	3
25	EC-1543-03	EC-1543-04	EC-1543-05	Monitor, Phase (<i>Optional</i>)	Ref

Item	50 Hz Applications			Description	Qty
	380	415	440		
1	EC-1556-09	EC-1556-08	EC-1556-08	Fuse, Class J	3
3	EC-1975	EC-1975	EC-1975	Controller, Softstart Motor	1
22	EC-1726-14	EC-1726-13	EC-1726-12	Fuse, Class CC (<i>Primary</i>)	2
23	EC-1596-01	EC-1596-01	EC-1596-01	Fuse Holder, Class J	3
25	EC-1543-03	EC-1543-04	EC-1543-05	Monitor, Phase (<i>Optional</i>)	Ref

9.12 HEAT EXCHANGER ASSEMBLY

The Heat Exchanger Assembly does not require regular general maintenance.

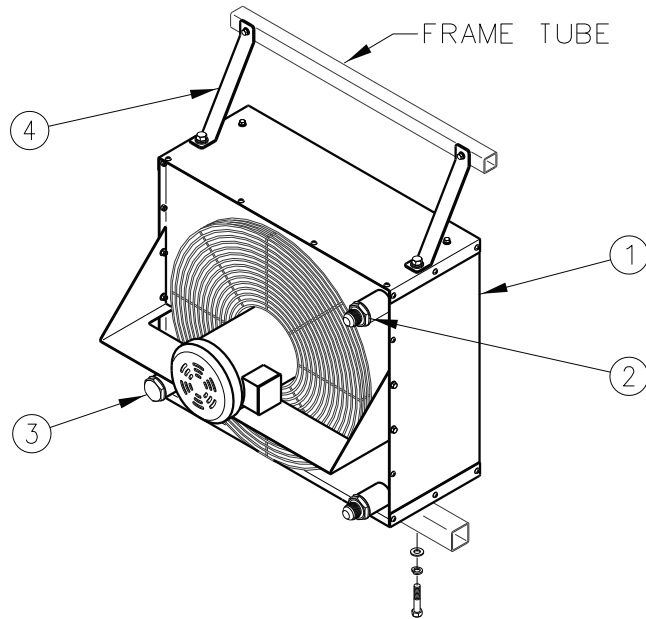

Parts List

Fluid Type: Aviation Phosphate Ester, Type IV

Item	Part Number	Description	Qty
1	Reference Table below	Heat Exchanger	1
2	N-2007-28-S-E	Connector, #20 SAE x #20 JIC	2
3	N-2066-20-S-E	Plug, #20 SAE (Hidden)	1
4	J-3403-01	Strap	2

Voltage	Frequency	Part Number
380V	60 Hz	HC-2138-01
460V	60 Hz	HC-2138-01
575V	60 Hz	HC-2138-02
380V	50 Hz	HC-2138-01
415V	50 Hz	HC-2138-01
440V	50 Hz	HC-2138-01

9.13 EXTERNAL COMPONENTS

Keep HPU clean. Do not allow labels to become damaged; thusly illegible. Regularly inspect casters and floor locks to ensure safe working condition.

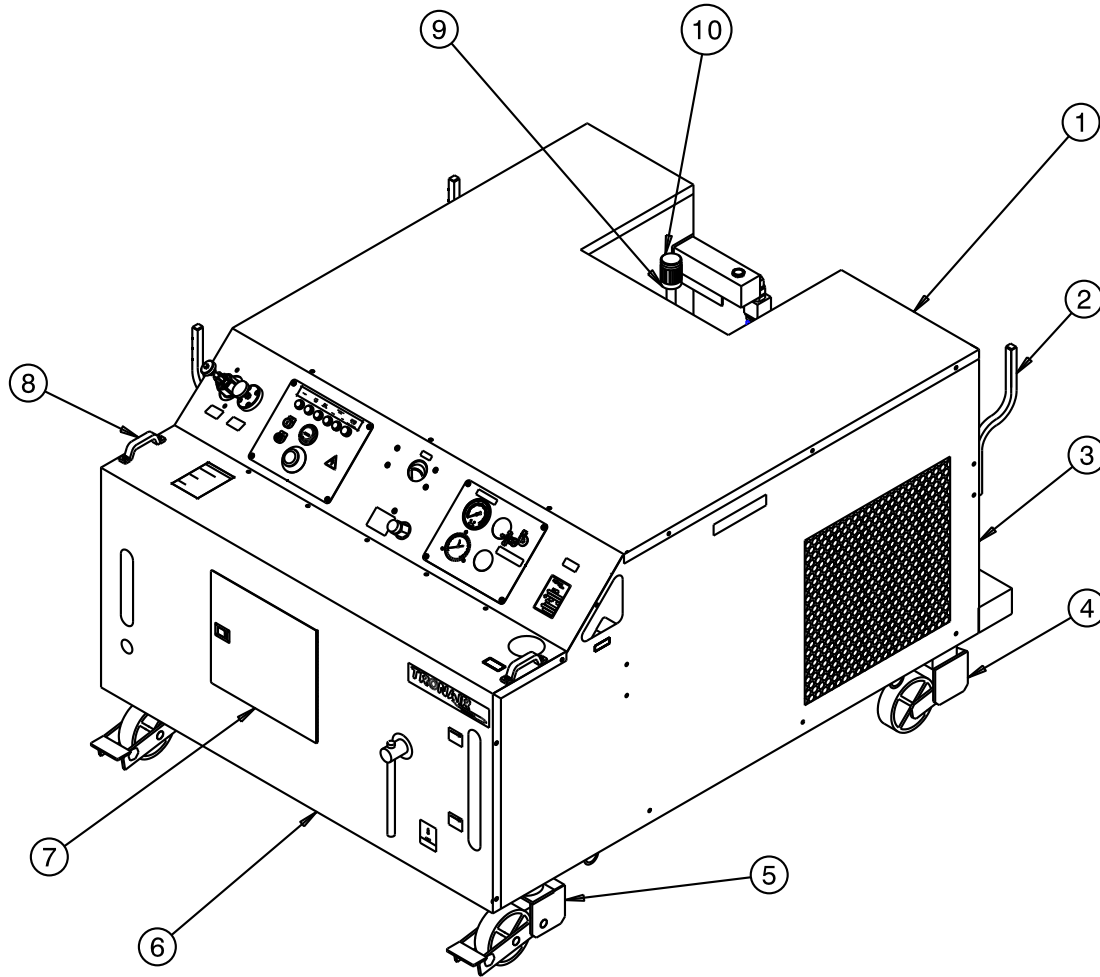

Parts List

Item	Part Number	Description	Qty
1	S-1799-01	Top Panel	1
2	Z-5549-01	Hanger	3
3	Z-5382-01	Right Side Panel	1
4	U-1102	Rigid Caster	2
5	U-1101	Swivel Caster	2
6	Z-9146	Front Panel	1
7	Z-5397	Front Access Door	1
8	H-1780	Handle	2
9	EC-1794	Box, Vertical Mount Junction	1
10	EC-1791	Light, Pole Mounted Stack	1
N/S	Z-5383-01	Left Side Panel	1
N/S	S-1804-01	Return Manifold Access Panel	1
N/S	S-1896-01	Skirt Panel (under Electrical Box)	1
N/S	S-1798-01	Back Panel	1

9.14 ADDITIONAL FEATURES

9.14.1 50 ft (15.2 m) Hoses (Option B)

Refer to Section **10.6 Hydraulic Hoses** concerning hose inspection.

Parts List

Fluid Type: Aviation Phosphate Ester, Type IV

Part Number	Description	Qty
TF-1040-05*300	Pressure Hose, 25 ft/7.6 m	1 per Option
TF-1041-04*300	Return Hose, 25 ft/7.6 m	1 per Option
N-2011-10-S	Union, #16	1 per Option
N-2011-12-S	Union, #12	1 per Option

9.14.2 Electric Reservoir Level (Option L)

The Electric Reservoir Level switch does not require regular general maintenance. Panel indicator lights will indicate low or high fluid level.

NOTE: Wire per Electrical Schematic INS-1608. Reference Wiring Diagram INS-1661. Reference 9.7.1 Electrical Panel for Panel Light.

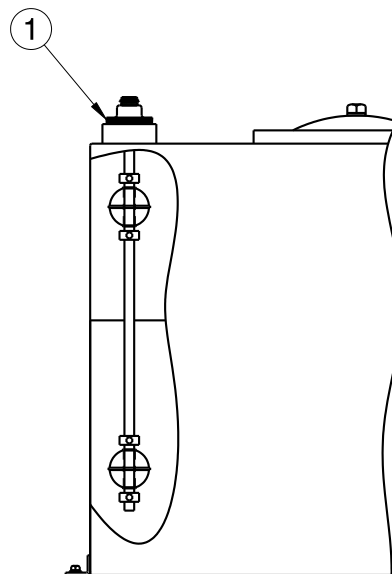

Parts List

Item	Part Number	Description	Qty
1	EC-1783	Multi-Level Switch (includes Plug-in Cable)	1

9.14.3 Hand Pump (Option M)

Refer to Section **9.6 Hydraulic Hoses** concerning hose inspection for general maintenance on Items 4, 5, 7 and 13 hose assemblies. Refer to Section **9.5.3 – Hand Pump (Optional) Filter**.

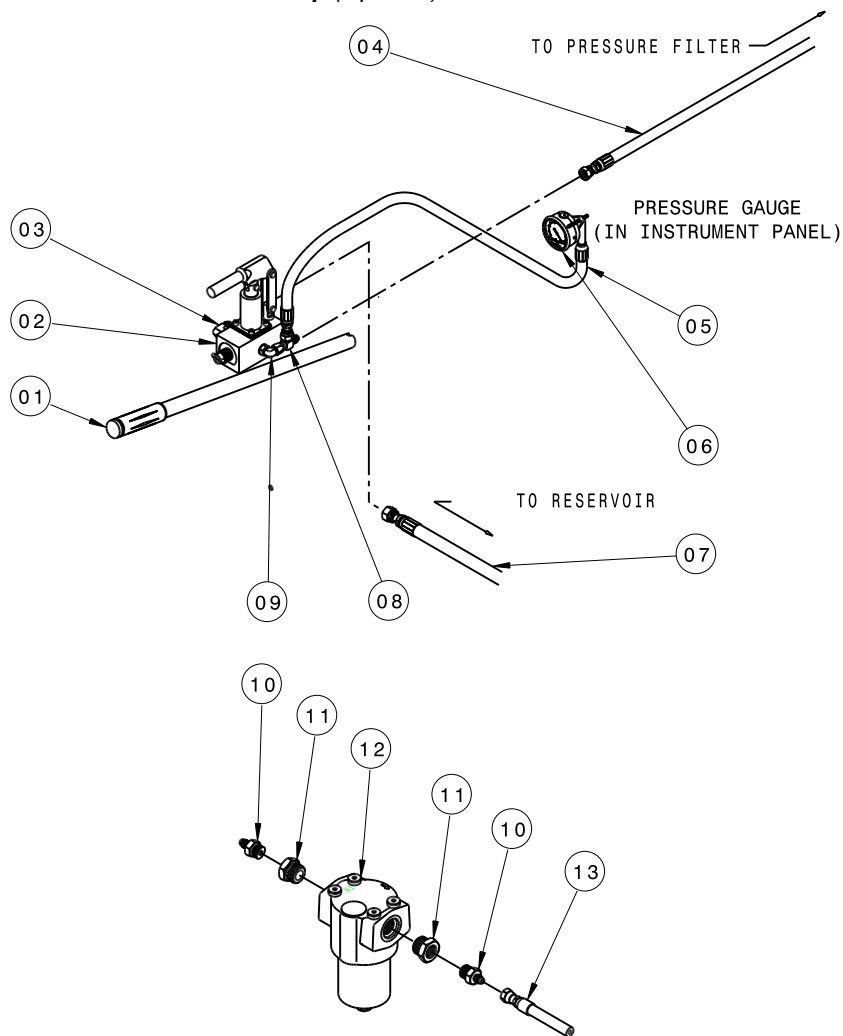

Parts List

Fluid Type: Aviation Phosphate Ester, Type IV

Item	Part Number	Description	Qty
1	H-1009-01	Pump Handle	1
2	HC-1779	Hand Pump, Two Stage	1
3	N-2001-11-S-E	Elbow, #8 SAE x #8 JIC Flare	1
4	TF-1041-05*66.0	Hose Assembly, #4	1
5	TF-1041-05*54.0	Hose Assembly, #4	1
6	HC-2146	Pressure Gauge	1
7	TF-1041-25*32.5	Hose Assembly, #8	1
8	N-2016-03-S	Tee, Swivel Nut, #4	1
9	N-2001-05-S-E	Elbow, #6 SAE x #4 JIC Flare	1
10	N-2007-06-S-E	Fitting, Male Connector	1
11	N-2463-10-S-E	Reducer Fitting	2
12	HC-1777	Pressure Filter	1
13	TF-1041-05*180	Hose Assembly, #4	1

9.14.3.a Two Stage Pump with Relief

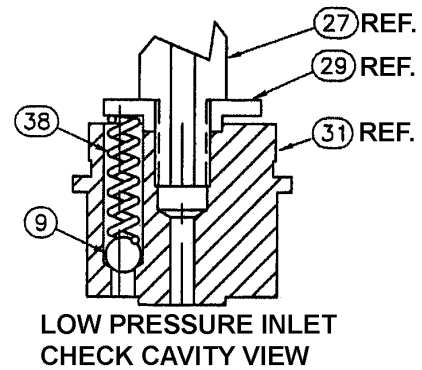
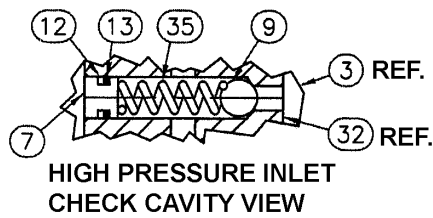
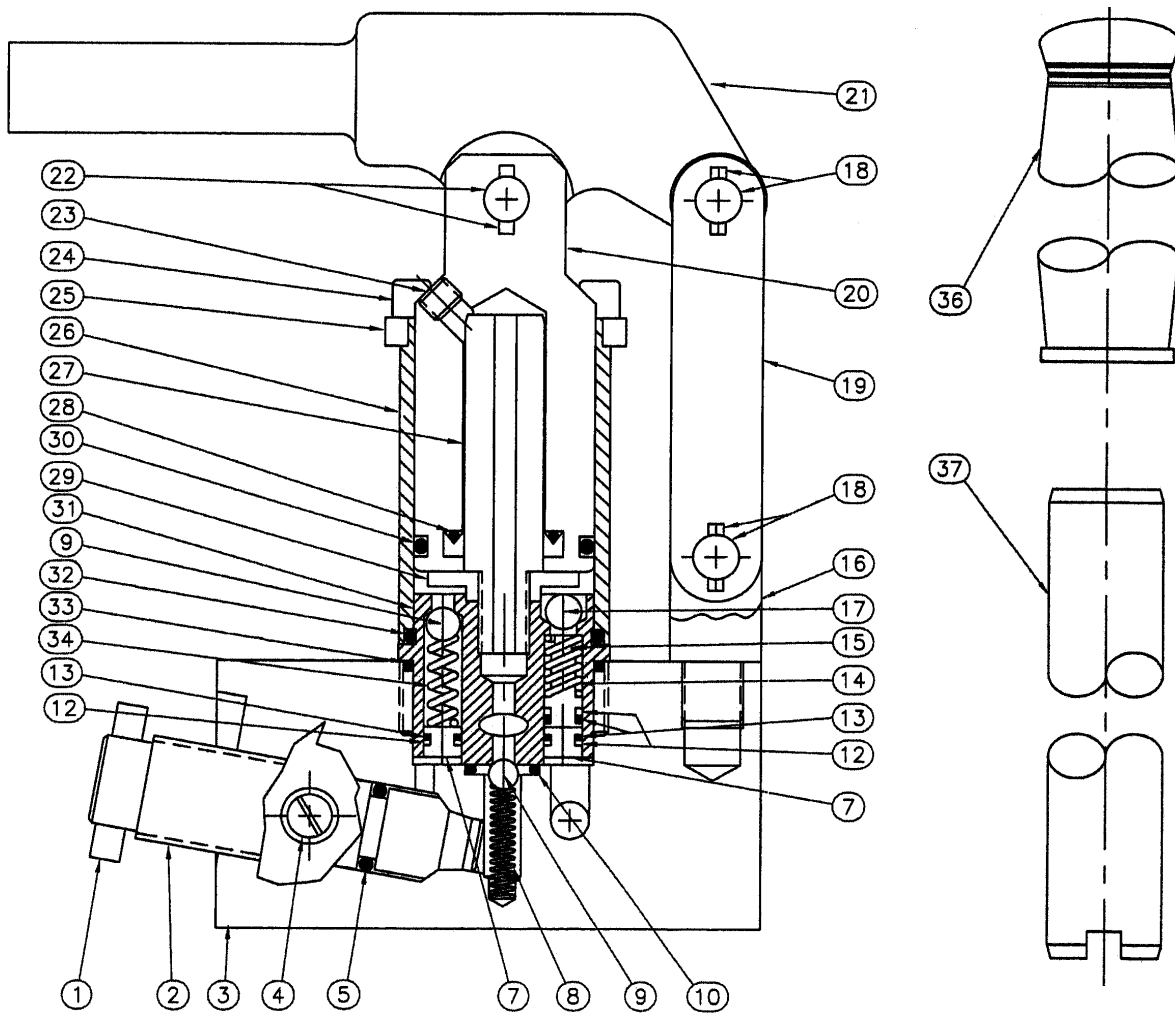

9.14.3.a Two Stage Pump with Relief (continued)

Parts List

Fluid Type: Aviation Phosphate Ester, Type IV

Item	Part Number	Description	Qty
1	519-000	Pin	1
3	CXC-990022-001	Body	1
7	505-001	Plug, Valve Body	3
15	571-121	Piston, Bypass Assembly	1
16	508-000	Pivot	1
20	566-125	Piston L.P	1
23	583-120	Plug	1
24	09-ADDF-04-20 X 56	Tie Rod	4
25	582-125	Flange	1
26	563-121	Tube	1
27	562-125	H.P. Piston	1
29	564-120	Retainer	1
31	560-120	Valve Body	1
36	H-1223	Grip, Handle	1
37	H-1009-01	Handle with Grip	1
	HK-1095	Kit, Internal Parts; consists of:	
6	(Not Shown)	Ball, Release	0
8		Spring, Outlet Check	1
9		Ball, Check	4
14		Spring, Bypass	1
17		Ball, Bypass	1
34		Spring, L.P. Outlet	1
35		Spring, H.P. Outlet	1
38		Spring, Intake L.P	1
	HK-1030	Kit, Pump Seal; consists of:	
5		O-ring, EPR	1
10		O-ring, EPR	1
12		Backup Ring (Teflon)	4
13		O-ring, EPR	4
28		H.P. Piston Seal	1
30		O-ring, EPR	1
32		O-ring, EPR	1
33		O-ring, EPR	1
	HK-1068	Kit, Pump Linkage; consists of:	
18		Pin Linkage Assembly	2
19		Strap	2
21		Handle Bracket	1
22		Clevis Pin Assembly	1
	HK-3117	Kit, Release Screw; consists of:	
2		Screw, Release/Relief	1
4		Retainer, Release Screw	1

9.14 Additional features continued on following page.

9.14.4 Towing Trailer (Option M)

Capacity 6,500 lbs (2,948 kg)
 Front Axle Capacity 3,250 lbs (1,474 kg)
 Rear Axle Capacity 3,250 lbs (1,474 kg)
 Tires 13x5x10 - Rated at 2,580 lbs (1,170 kg) at 6 mph (9.6 kph)

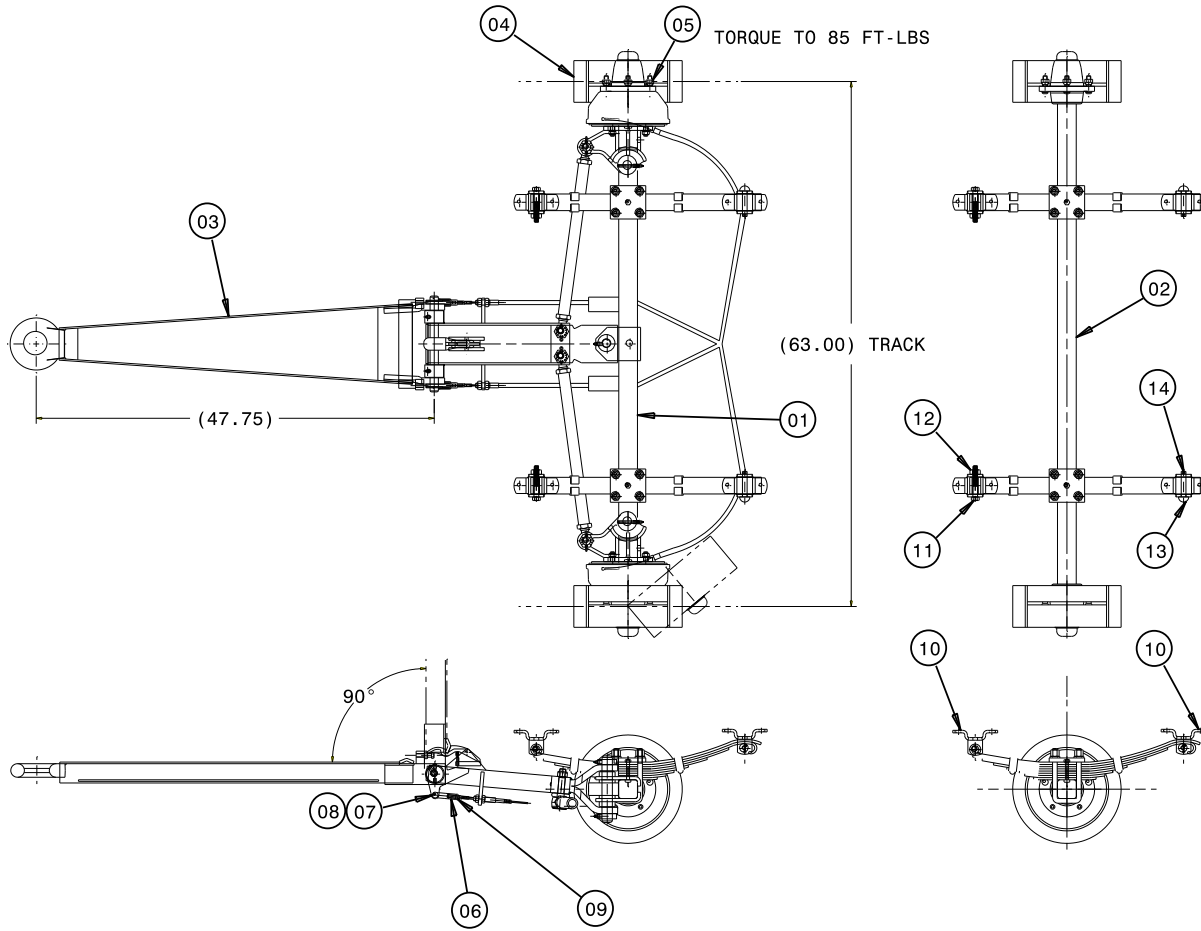

Parts List

Item	Part Number	Description	Qty
1	9-2196	Assembly, Front Axle	1
2	18-2146	Assembly, Rear Axle	1
3	47-3504	Assembly, Drawbar	1
4	1-3761	Assembly, Wheel & Tire	4
5	4603-1	Nut, Wheel ½-20 UN	20
6	5205	Yoke	2
7	5206	Pin, Yoke	2
8	4800-2	Pin, Cotter 3/32 x 0.75	2
9	4601-47	Nut, Hex 3/8 -24 NF	2
10	4251	Bracket, Spring	8
11	4901-19	Bolt, Grade 5, 9/16 -12 UN x 3.75" long	4
12	4601-33	Nut, Hex, 9/16 -12 UN	4
13	5403-1	Rivet	4
14	4800-3	Pin, Cotter, 1/8 x 1" long	4

9.15 REPLACEMENT LABELS PARTS LISTS

9.15.1 Base Unit

Part Number	Description	Qty
V-1001	"Made in USA"	1
V-1033	"TRONAIR"	1
V-1050	ISO Electrical Shock Symbol	2
V-1348	"FLOW (Increase)"	1
V-1366	"HPU BY-PASS VALVE"	1
V-1374	"ROTATION"	1
V-1470	"CAUTION..."	1
V-1882	Control Panel Lights	1
V-1883	"HOUR METER"	1
V-1884	"FLOWMETER"	1
V-1886	"PYROMETER"	1
V-1888	"SHUT-OFF/CALIBRATION PORT"	1
V-1893	"SAMPLE VALVE"	1
V-1894	"PRESSURE"	1
V-1895	"RETURN"	1
V-1896	"MAXIMUM OIL LEVEL"	1
V-1897	"MINIMUM OIL LEVEL"	1
V-1898	"PRESSURE and FLOW CONTROLS INSIDE"	1
V-1900	"WARNING KEEP 5 FT CLEAR..."	2
V-1914	Reservoir Selector Valve	1
V-1918	"PE"	1
V-1919	"OPERATING INSTRUCTIONS..."	1

9.15.2 Fluid Labels

Fluid Type: Aviation Phosphate Ester, Type IV

Part Number	Description	Qty
V-1977	"PHOSPHATE ESTER FLUIDS ONLY"	2

9.15.3 Filter Element Kit Labels

Fluid Type: Aviation Phosphate Ester, Type IV

Part Number	Description	Qty
V-1956	"REPLACEMENT FILTER ELEMENT K-3588"	1
V-1955	"REPLACEMENT FILTER ELEMENT K-3587"	1
V-1916	"REPLACEMENT DESICCANT FILTER ELEMENT HC-1763"	1

9.15.4 Split System (*Option C*) Labels

Part Number	Description	Qty
V-2004	"SYSTEM 1 PRESSURE"	1
V-2005	"SYSTEM 2 PRESSURE"	1
V-2006	"SYSTEM 1 RETURN"	1
V-2007	"SYSTEM 2 RETURN"	1

9.15.5 Hand Pump (*Option M*) Labels

Part Number	Description	Qty
V-1887	"HAND PUMP PRESSURE"	1
V-1915	"HAND PUMP"	1
V-1989	"REPLACEMENT FILTER ELEMENT K-3752"	1

10.0 PROVISION OF SPARES

10.1 SOURCE OF SPARE PARTS

TRONAIR, Inc.
1 Air Cargo Pkwy East
Swanton, Ohio 43558 USA

Telephone: (419) 866-6301 or 800-426-6301
Fax: (419) 867-0634
E-mail: sales@tronair.com
Website: www.tronair.com

10.2 RECOMMENDED SPARE PARTS LISTS

It is recommended that the following spare parts be kept on hand and available for immediate use during maintenance.

10.2.1 Spare Electrical Parts

Part Number	Description	Qty
Refer to Section 9.10 Electrical Components Item 22	Fuse, Transformer Primary	2
EC-1542-12	Fuse, Transformer Secondary	1
Refer to Section 9.10 Electrical Components Item 24	Fuse, Heat Exchanger	3
EC-1675-12	Fuse, Phase Monitor (<i>Optional</i>)	3
Refer to Section 10.11 Electrical Components Item 1		

10.2.2 Spare Parts

Fluid Type: Aviation Phosphate Ester, Type IV

Part Number	Description	Qty
HC-1763	Desiccant Filter Element	1
K-3588	Kit, Pressure Filter Element	1
K-3587	Kit, Return Filter Element	1
*	Kit, Shaft Seal	1
K-3752	Kit, Hand Pump Filter Element (<i>Optional</i>)	1

* **Call Tronair for details**

11.0 CALIBRATION OF INSTRUMENTATION

All gauges on the Hydraulic Power Unit can be either returned to Tronair for calibration or certified by the end user if proper calibration equipment is available. Gauges returned to Tronair for calibration will be tested with standards traceable to N.I.S.T. (National Institute of Standards and Technology). Tronair recommends calibration of instrumentation at yearly intervals, but actual calibration dates may be based upon frequency of use and the end users quality system. For information on returning gauges for calibration, Reference 12.1 – Source of Calibration.

11.1 SOURCE OF CALIBRATION

TRONAIR, Inc.
1 Air Cargo Pkwy East
Swanton, Ohio 43558 USA

Telephone: (419) 866-6301 or 800-426-6301
Fax: (419) 867-0634
E-mail: sales@tronair.com
Website: www.tronair.com

11.2 ANALOG PRESSURE GAUGE – System Pressure

11.2.1 Self Calibration

An accurate pressure calibration gauge is required for calibration of the System Pressure gauge. There are two methods available. Method A can be used if the HPU is equipped with a calibration port (*Option Q*). Method B must be used if the HPU is **not** equipped with a calibration port. Follow the necessary steps below.

NOTE: Method A can only test the gauge up to the rated operating pressure of the HPU (4,000 psi).

Method A: Shut off HPU and disconnect from aircraft. Close the calibration port **Shut-off Valve** on the instrument panel of the HPU. Attach the “Master” calibration gauge to the **Calibration Port** on the instrument panel.

Set up the HPU as follows:

Reservoir Selector Valve..... Set to HPU Reservoir
Bypass Valve Open
Pressure Ball Valves (at rear of unit)..... Closed
Return Ball Valves (at rear of unit) Closed

Start the HPU. Open the calibration port Shut-off Valve. Close the Bypass valve to build system pressure. Record gauge values at the designated increments.

Open the Bypass valve.

Shut off the HPU and close the calibration port Shut-off Valve before disconnecting the “Master” calibration gauge.

Method B: Shut off the HPU and disconnect it from the power source. Remove the **Hydraulic Panel** from the front instrument panel (four screws). Disconnect the hose from the System Pressure gauge (remove gauge from panel if necessary). Attach calibration test equipment to the gauge and record gauge values at the designated increments.

SYSTEM PRESSURE GAUGE (HC-2144)

Applied Pressure (System Pressure Gauge) (psig)	Minimum Acceptable (psig)	Maximum Acceptable (psig)	Gauge Movement (Direction)	Indicated Pressure (Calibration Gauge) (psig)
1000	910	1090	Increasing	
2000	1910	2090	Increasing	
3000	2910	3090	Increasing	
4000	3910	4090	Increasing	
5000	4910	5090	Increasing	
6000	5910	6090	Increasing	
5000	4910	5090	Decreasing	
4000	3910	4090	Decreasing	
3000	2910	3090	Decreasing	
2000	1910	2090	Decreasing	
1000	910	1090	Decreasing	
Allowable operating tolerance: +/- 1.5% of full scale (90 psig) at room temperature (70° F).				

11.3 ANALOG PRESSURE GAUGE (Hand Pump Pressure- *Option M Only*)

11.3.1 Self Calibration

An accurate pressure calibration gauge is required for calibration of the Hand Pump Pressure gauge. Follow the necessary steps below.

Shut off the HPU and disconnect it from the power source. Remove the **Hydraulic Panel** from the front instrument panel (four screws). Disconnect the hose from the Hand Pump Pressure gauge (remove gauge from panel if necessary). Attach calibration test equipment to the gauge and record gauge values at the designated increments.

HAND PUMP PRESSURE GAUGE (HC-2146)

Applied Pressure (Hand Pump Pressure Gauge) (psig)	Minimum Acceptable (psig)	Maximum Acceptable (psig)	Gauge Movement (Direction)	Indicated Pressure (Calibration Gauge) (psig)
1000	700	1300	Increasing	
2000	1700	2300	Increasing	
5000	4800	5200	Increasing	
8000	7700	8300	Increasing	
10,000	9700	10,300	Increasing	
8000	5940	8300	Decreasing	
5000	4800	5200	Decreasing	
2000	1700	2300	Decreasing	
1000	700	1300	Decreasing	

Allowable operating tolerance: +/- 3% of full scale (300 psig) at room temperature (70° F).
+/- 2% of full scale for middle third of scale (200 psig) at room temperature (70° F).

11.4 ANALOG TEMPERATURE GAUGE (*Pyrometer*)

11.4.1 Self Calibration

An accurate temperature calibration gauge is required for calibration of the Pyrometer. The pyrometer bulb is located in the return manifold (rear of unit) and can be accessed by removal of the HPU top panel. See Section 9.7.2 – Pyrometer for location. Follow the necessary steps below.

- 1 Remove the pyrometer bulb from the return manifold by removing the slotted brass nut that retains the bulb in the well.
- 2 Connect the temperature calibration gauge to the bulb of the pyrometer.

The Temperature Value Must Be:

Pyrometer Temperature Display (° F)	Minimum Acceptable (° F)	Maximum Acceptable (° F)	Temperature Calibration gauge (° F)
160	158	162	

12.0 IN SERVICE SUPPORT

Contact Tronair, Inc. for technical services and information. See Section 1.3 – Manufacturer.

13.0 GUARANTEES/LIMITATION OF LIABILITY

Tronair products are warranted to be free of manufacturing or material defects for a period of one year after shipment to the original customer. This is solely limited to the repair or replacement of defective components. This warranty does not cover the following items:

- a) Parts required for normal maintenance
- b) Parts covered by a component manufacturers warranty
- c) Replacement parts have a 90-day warranty from date of shipment

If you have a problem that may require service, contact Tronair immediately. Do not attempt to repair or disassemble a product without first contacting Tronair, any action may affect warranty coverage. When you contact Tronair be prepared to provide the following information:

- a) Product Model Number
- b) Product Serial Number
- c) Description of the problem

If warranty coverage is approved, either replacement parts will be sent or the product will have to be returned to Tronair for repairs. If the product is to be returned, a Return Material Authorization (RMA) number will be issued for reference purposes on any shipping documents. Failure to obtain a RMA in advance of returning an item will result in a service fee. A decision on the extent of warranty coverage on returned products is reserved pending inspection at Tronair. Any shipments to Tronair must be shipped freight prepaid. Freight costs on shipments to customers will be paid by Tronair on any warranty claims only. Any unauthorized modification of the Tronair products or use of the Tronair products in violation of cautions and warnings in any manual (including updates) or safety bulletins published or delivered by Tronair will immediately void any warranty, express or implied.

The obligations of Tronair expressly stated herein are in lieu of all other warranties or conditions expressed or implied. **Any unauthorized modification of the Tronair products or use of the Tronair products in violations of cautions and warnings in any manual (including updates) or safety bulletins published or delivered by Tronair will immediately void any warranty, express or implied and Tronair disclaims any and all liability for injury (WITHOUT LIMITATION and including DEATH), loss or damage arising from or relating to such misuse.**

14.0 APPENDICES

APPENDIX I	Declaration of Conformity
APPENDIX II	Hydraulic Schematic (INS-2370)
APPENDIX III	Electrical Schematic (INS-2238)
APPENDIX IV	Wiring Diagram (INS-1664)
APPENDIX V	Lincoln Motor Manual
APPENDIX VI	Denison Pump Manual – Premier Series P07
APPENDIX VII	Safety Data Sheet (SDS) pertaining to Hydraulic Fluid
APPENDIX VIII	Instrument Certification Notice



APPENDIX I

Declaration of Conformity



Declaration of Conformity

The design, development and manufacture is in accordance with European Community guidelines

Mobile Hydraulic Power Unit (Electric Motor Driven)

Relevant draft complied with by the machinery:
prEN 1915-1:1995

Relevant standards complied with by the machinery:
prEN 982:1996
prEN 60204-1:1997
HFPA/JIC T2.24.1-1990
ISO 4021:1997
ARP 1247B
NFPA 70/NEC 1999

Identification of person empowered to sign on behalf of the Manufacturer:

A handwritten signature in black ink that reads "Patrick Finch". The signature is written in a cursive style and is positioned above a solid horizontal line.

Quality Assurance Representative



APPENDIX II

**Hydraulic Schematic
(INS-2370)**

THIS DRAWING IS THE PROPERTY OF TRONAIR, INC. IT IS FURNISHED TO YOU FOR CONFIDENTIAL INFORMATION PURPOSES ONLY AND IS NOT TO BE DISCLOSED TO ANYONE ELSE OR REPRODUCED OR USED FOR MANUFACTURING PURPOSES WITHOUT THE EXPRESS WRITTEN PERMISSION OF TRONAIR, INC.

LET	REVISION	ECN	DWN	CHK	DATE
A	ORIGINAL RELEASE	20309	-	-	01-30-17

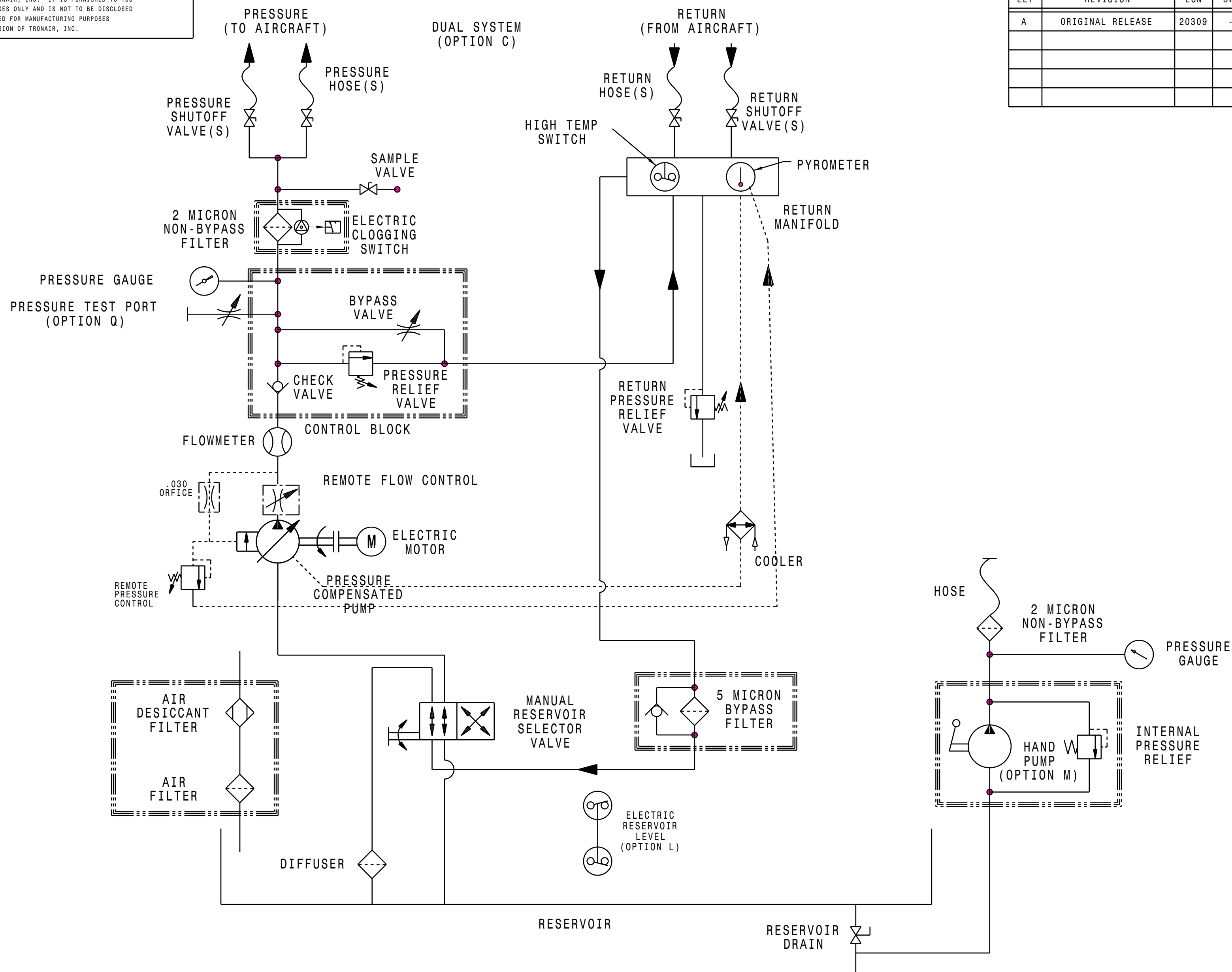

MAKE FROM:	N / A
MATERIAL:	N / A
FINISH:	N / A
REFERENCE:	N / A
SCALE:	FULL
TYPE:	N / A
SIZE:	C
DO NOT SCALE DRAWING	

BREAK ALL SHARP EDGES AND CORNERS
TOLERANCES UNLESS OTHERWISE SPECIFIED

DECIMAL	.X	± .100
	.XX	± .030
	.XXX	± .010
FRACTION	X/XX	± 1/16

ANGLES: ± 1/2 DEGREE
< > INDICATES CRITICAL DIMENSIONS
() INDICATES REFERENCE DIMENSIONS

TRONAIR AIRCRAFT GROUND SUPPORT EQUIPMENT

DWN BY CDG CKD BY PEH 01-31-17

SCHEMATIC, HYDRAULIC

05	INS-2370	REV A
----	----------	-------



APPENDIX III

**Electrical Schematic
(INS-2238)**

THIS DRAWING IS THE PROPERTY OF TRONAIR, INC. IT IS FURNISHED TO YOU FOR CONFIDENTIAL INFORMATION PURPOSES ONLY AND IS NOT TO BE DISCLOSED TO ANYONE ELSE OR REPRODUCED OR USED FOR MANUFACTURING PURPOSES WITHOUT THE EXPRESS WRITTEN PERMISSION OF TRONAIR, INC.

LET	REVISION	ECN	DWN	CHK	DATE
A	ORIGINAL RELEASE	19173	-	-	11-27-13
B	ADDED WIRES 70 & 71	21208	ADO	PEH	03-19-19

COMPONENT ABBREVIATION
 MS - MOTOR STARTER
 SS - SOFT START
 MTR - MOTOR
 SJ - SWITCH
 CR - CONTROL RELAY
 HR - HOURMETER
 FU - FUSE
 TR - TRANSFORMER
 LT - LIGHT
 SN - SENSOR
 PE - POTENTIAL EARTH

WIRE COLORS:
 - LT - BLUE
 - NE - RED
 - INTERCONNECTION - RED
 - 3-PHASE GROUND - GREEN-YELLOW

(X) - DEVICE TERMINATION
 [] - TERMINAL BLOCK CONNECTION
 1TB - GROUND TERMINAL BLOCK
 2TB - NEUTRAL TERMINAL BLOCK
 3TB - CONTROL TERMINAL BLOCK
 --- OPTIONS JUMPER

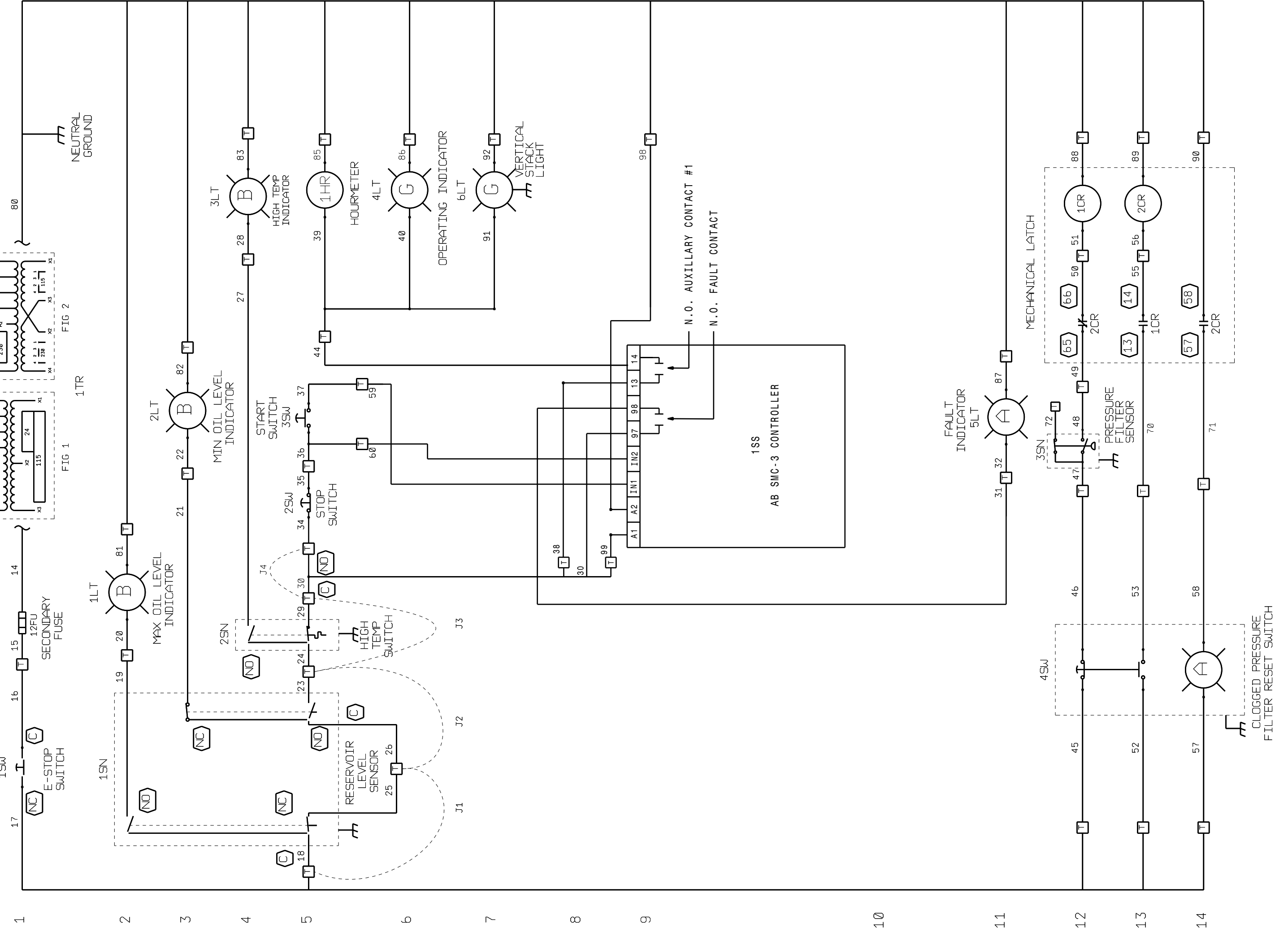
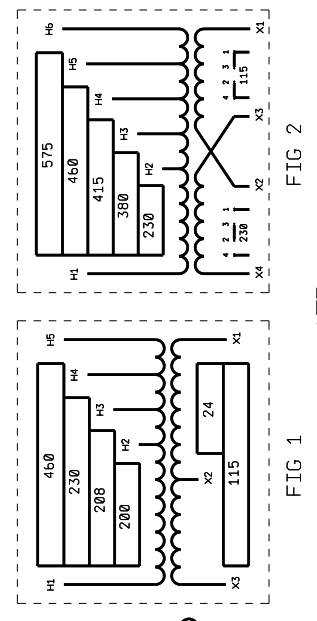
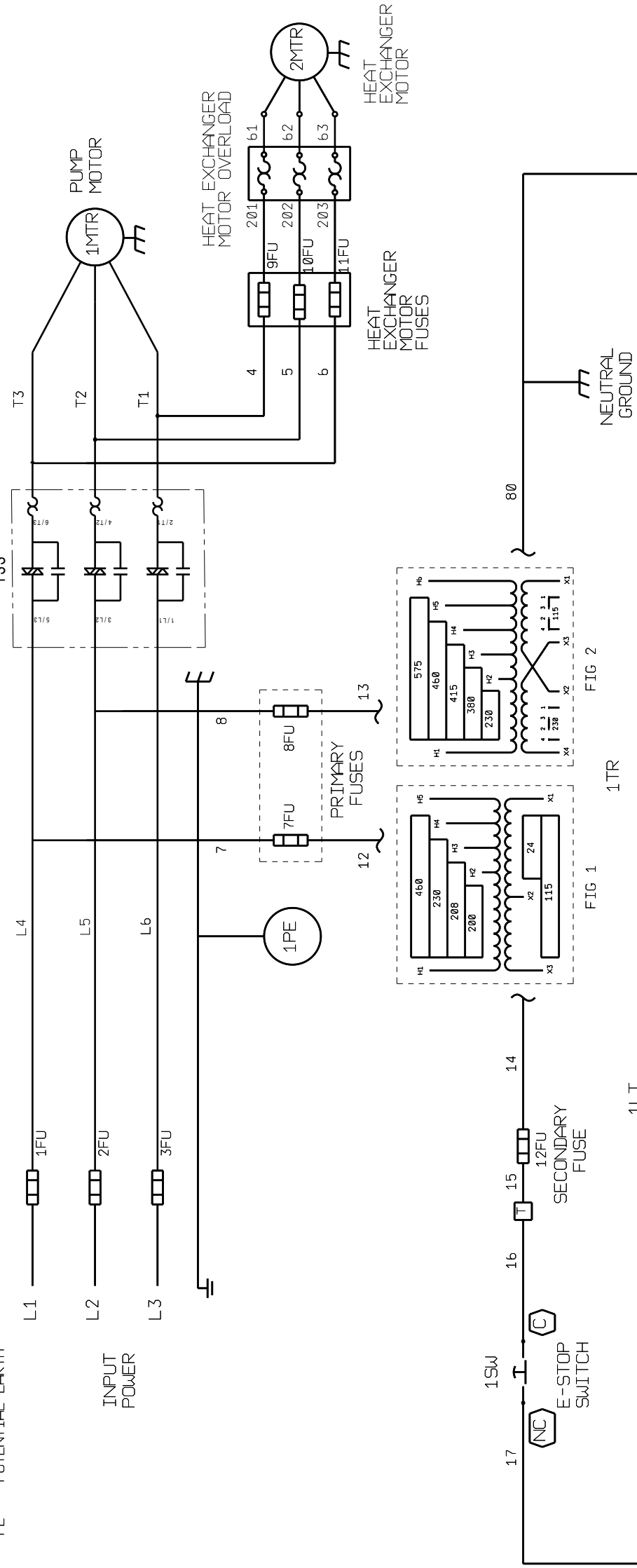

MAKE FROM: N / A	TYPE: N / A
MATERIAL: N / A	FINISH: MILL
REFERENCE:	SIZE []
SCALE: N. S. R.	DO NOT SCALE DRAWING

BREAK ALL SHARP EDGES AND CORNERS
 TOLERANCES UNLESS OTHERWISE SPECIFIED

DECIMAL .X ± .100
 .XX ± .030
 .XXX ± .010
 FRACTION X/XX ± 1/16
 ANGLES: ± 1/2 DEGREE

< > INDICATES CRITICAL DIMENSIONS
 () INDICATES REFERENCE DIMENSIONS

TRONAIR AIRCRAFT GROUND SUPPORT EQUIPMENT

DWN BY WCG CKD BY PEH 11-27-13

SCHEMATIC, HPU ELECTRICAL (CE/CSA)

05 INS-2238 REV B



APPENDIX IV

Wiring Diagram (INS-1664)

THIS DRAWING IS THE PROPERTY OF TRONAIR, INC. IT IS FURNISHED TO YOU FOR CONFIDENTIAL INFORMATION PURPOSES ONLY AND IS NOT TO BE DISCLOSED TO ANYONE ELSE OR REPRODUCED OR USED FOR MANUFACTURING PURPOSES WITHOUT THE EXPRESS WRITTEN PERMISSION OF TRONAIR, INC.

LET	REVISION	EDN	DJN	CHK	DATE
-	ORIGINAL RELEASE	11765	-	-	05-18-01
A	1. ADDED STACK LT. 2. WIRE 93 WPS 91 3. UPDATED GEOMETRY	12249	WCG	PEH	11-04-02
B	CHANGED SOFT START AND WIRING	15354	WCG	PEH	05-06-08
C	ADDED TERMINALS	16953	JMB	PEH	04-15-09
D	DELETED 41, 42, 61 TERMINALS	18738	JMB	PEH	09-20-12
E	ADDED WIRES 70 & 71	21208	ADD	PEH	03-19-19

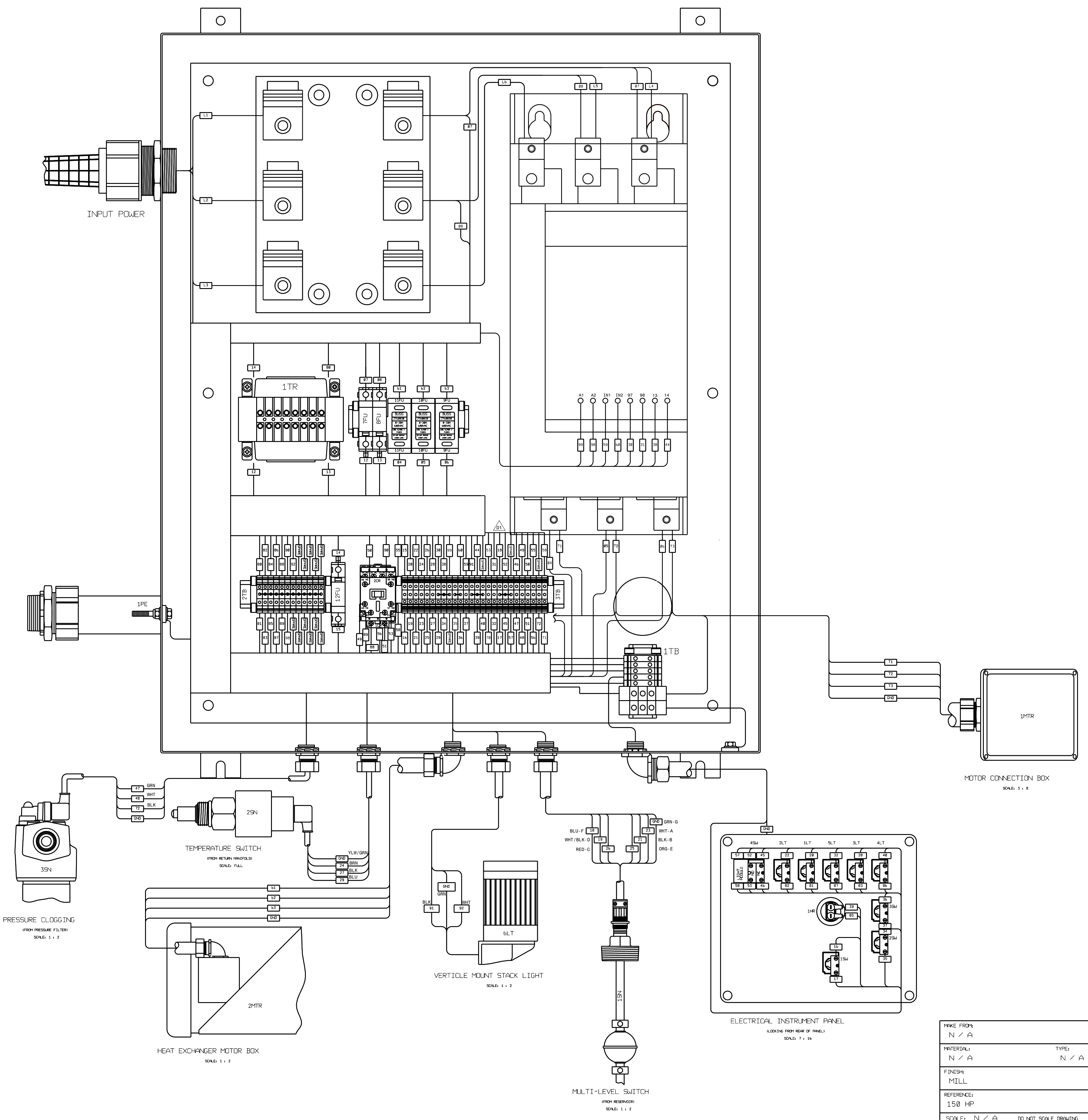

MAKE FRIDS N / A MATERIAL: N / A FINISH: MILL REFERENCE: 150 HP SCALE: N / A DO NOT SCALE DRAWING	TYPE: N / A SIZE: D	BREAK ALL SHARP EDGES AND CORNERS TOLERANCES UNLESS OTHERWISE SPECIFIED DECIMAL .X ± .100 .XX ± .030 .XXX ± .010 FRACTION X/XX ± 1/16 ANGLES: ± 1/2 DEGREE < > INDICATES CRITICAL DIMENSIONS () INDICATES REFERENCE DIMENSIONS	TRONAIR AIRCRAFT GROUND SUPPORT EQUIPMENT DWN BY SJD CKD BY WJL 05-18-01 INSTRUCTION, WIRING DIAGRAM (CE) 05 INS-1664 REV E
---	------------------------------	---	---



APPENDIX V

Lincoln Motor Manual

Carefully read and fully understand this Owner's Manual prior to installation, operation and maintenance of your motor.

1. SAFETY DEPENDS ON YOU

Lincoln motors are designed and manufactured with safety in mind. However, your overall safety can be increased by properly installing, operating and maintaining the motor. Read and observe all instructions, warnings and specific safety precautions included in this manual and **THINK BEFORE YOU ACT!**

2. RECEIVING AND INSPECTION

Check packing list and inspect motor to make certain no damage has occurred in shipment. Claims for any damage done in shipment must be made by the purchaser against the transportation company.

Turn the motor shaft by hand to be certain that it rotates freely. Be careful not to cut yourself on the shaft keyway; it is razor sharp!

Check the nameplate for conformance with power supply and control equipment requirements.

3. HANDLING

 WARNING	
	FALLING EQUIPMENT can injure.
	<ul style="list-style-type: none"> ● Lift only with equipment of adequate lifting capacity. ● If so equipped, use lift ring(s) on the motor to lift ONLY the motor and accessories mounted by Lincoln.

In case of assemblies on a common base, the motor lift ring(s) **CANNOT** be used to lift the assembly and base but, rather, the assembly should be lifted by a sling around the base or by other lifting means provided on the base. In all cases, care should be taken to assure lifting in the direction intended in the design of the lifting means. Likewise, precautions should be taken to prevent hazardous overloads due to deceleration, acceleration or shock forces.

4. STORAGE

Motor stock areas should be clean, dry, vibration free and have a relatively constant ambient temperature. For added bearing protection while the motor is in storage, turn the motor shaft every six months.

A motor stored on equipment and component equipment prior to installation should be kept dry and protected from the weather. If the equipment is exposed to the atmosphere, cover the motor with a waterproof cover. Motors should be stored in the horizontal position with drains operable and positioned in the lowest point. **CAUTION:** Do not completely surround the motor with the protective covering. The bottom area should be open at all times.

Windings should be checked with a megohm-meter (Megger) at the time equipment is put in storage. Upon removal from storage, the resistance reading must not have dropped more than 50% from the initial reading. Any drop below this point necessitates electrical or mechanical drying. Note the sensitivity of properly connected megohm-meters can deliver erroneous values. Be sure to carefully follow the megohm-meter's operating instructions when making measurements.

All external motor parts subject to corrosion, such as the shaft and other machined surfaces, must be protected by applying a corrosion-resistant coating.

5. INSTALLATION

For maximum motor life, locate the motor in a clean, dry, well ventilated place easily accessible for inspecting, cleaning and lubricating. The temperature of the surrounding air should not exceed 104°F (40°C) except for motors with nameplates indicating a higher allowable maximum ambient temperature.

 WARNING	
	MOVING PARTS can injure.
	<ul style="list-style-type: none"> ● BEFORE starting motor, be sure shaft key is captive. ● Consider application and provide guarding to protect personnel.

5.1 INSTALLATION – MECHANICAL

Base

Mount the motor on a firm foundation or base sufficiently rigid to prevent excessive vibration. On foot-mounted motors, use appropriately sized bolts through all four mounting holes. For frames which have six or eight mounting holes, use the two closest the drive shaft and two on the end opposite the drive shaft (one on each side of the frame). If necessary, properly shim the motor to prevent undue stress on the motor frame and to precision align the unit.

Position

Standard motors may be mounted in any position. The radial and thrust load capacity of the motor's bearing system provides for this feature.

Drains

All motors have drain holes located in the end brackets. As standard, drains are in place for the horizontal with feet down mounting position. Other positions may require either rotation of the end brackets or drilling additional holes to attain proper drainage. Be sure existing drain or vent holes do not permit contaminant entry when motor is mounted in the other positions.

Additional drain holes exist near the bearing cartridge in both end brackets of 284T thru 449T steel frame motors. The drain holes are closed with a plastic plug. When the motor is vertically mounted, the plug located in the lower end bracket must be removed. To access the plug on blower end, simply remove the shroud; on some models, it is also necessary to take off the blower.

Drive – Power Transmission

The pulley, sprocket, or gear used in the drive should be located on the shaft as close to the shaft shoulder as possible. Do not drive the unit on the shaft as this will damage the bearings. Coat the shaft lightly with heavy oil before installing pulley.

Belt Drive: Align the pulleys so that the belt(s) will run true. Consult the belt manufacturer's catalog for recommended tension. Properly tension the belt; excessive tension will cause premature bearing failure. If possible, the lower side of the belt should be the driving side. On multiple belt installations be sure all belts are matched for length.

Chain Drive: Mount the sprocket on the shaft as close to the shaft shoulder as possible. Align the sprockets so that the chain will run true. Avoid excessive chain tension.

Gear Drive and Direct Connection: Accurate alignment is essential. Secure the motor and driven unit rigidly to the base. Shims may be needed to achieve proper alignment.

Excessive motor vibration may result if the full length of the motor shaft key is not completely engaged by the coupling or sheave. For these situations, adjustment of the key length is required.

5.2 INSTALLATION – ELECTRICAL

⚠ WARNING

ELECTRIC SHOCK can kill.

- Disconnect input power supply before installing or servicing motor.
- Motor lead connections can short and cause damage or injury if not well secured and insulated.

- Use washers, lock washers and the largest bolt size which will pass through the motor lead terminals in making connections.
- Insulate the connection, equal to or better than the insulation on the supply conductors.
- Properly ground the motor — see GROUNDING.

Check power supply to make certain that voltage, frequency and current carrying capacity are in accordance with the motor nameplate.

Proper branch circuit supply to a motor should include a disconnect switch, short circuit current fuse or breaker protection, motor starter (controller) and correctly sized thermal elements or overload relay protection.

Short circuit current fuses or breakers are for the protection of the branch circuit. Starter or motor controller overload relays are for the protection of the motor.

Each of these should be properly sized and installed per the National Electrical Code and local codes.

Properly ground the motor – See GROUNDING.

Terminal Box

Remove the appropriate knockout. For terminal boxes without a knockout, either a threaded power-conduit entry hole is provided or the installer is responsible for supplying a correctly sized hole.

The majority of terminal boxes can be rotated in place to allow power lead entry from the 3, 6, 9 or 12 o'clock direction.

Motor Connection

All single speed and two-speed Lincoln motors are capable of across-the-line or autotransformer starting. Reference the lead connection diagram located on the nameplate or inside of the terminal box cover.

Single speed motors have reduced voltage start capability per the following chart.

Number of Motor Leads	Number of Rated Voltages	Lead Numbers	YDS	PWS
3	Single	1-3	No	No
6	Single	1-3, 7-9	No	Yes
	Dual	1-6	Yes ⁽¹⁾	No
9	Dual	1-9	No	No
12	Single	1-12	Yes	Yes
	Dual	1-12	Yes	No ⁽²⁾

(1) YDS capability on lower voltage only.

(2) PWS capability on lower voltage only, 1200 RPM, 324T-365T steel frame motors with Model Number efficiency letters of "S" or "H".

Contact Customer Service at 1-800-668-6748 (phone), 1-888-536-6867 (fax) or mailbox@lincolnmotors.com (e-mail) for a copy of across-the-line and other reduced voltage start connection diagrams.

Connection Diagram 1

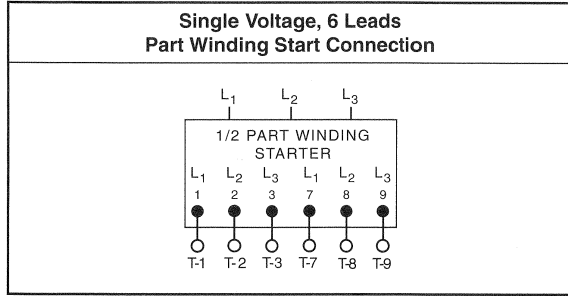

Connection Diagram 2

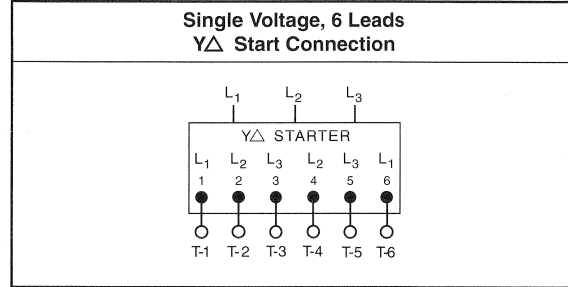

Connection Diagram 3

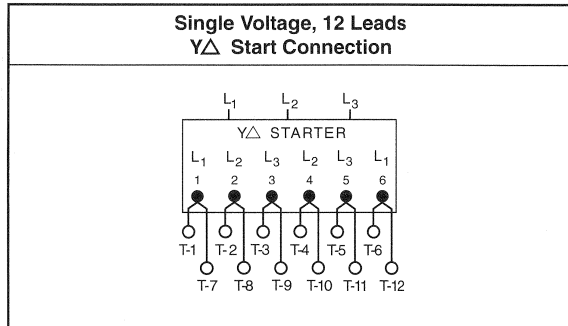

Connection Diagram 4

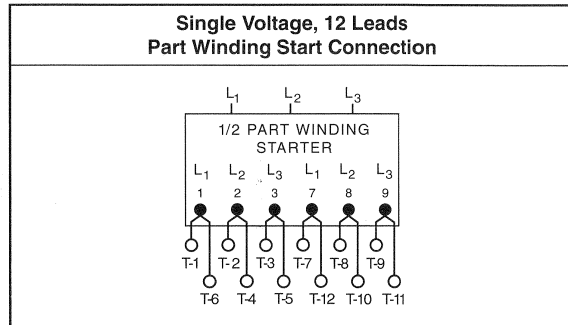

Connection Diagram 5

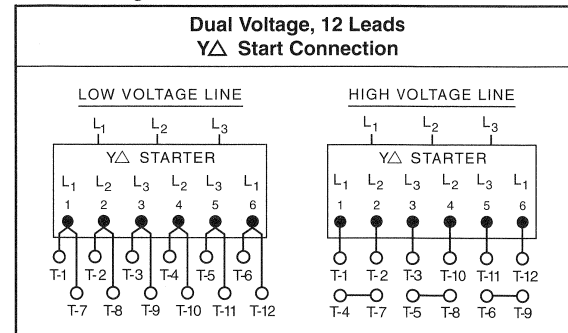

Space Heater (option)

Leads for space heaters are identified as H1 and H2. Heater voltage and watts are marked on the motor nameplate and should be checked prior to connection to power source.

Thermostat (option)

Leads for thermostats (normally closed, automatic reset contacts) are identified as P1 and P2. Connect these to a relay or signaling device. Motor line current cannot be handled by the thermostat.

Table 1 — Thermostat Contact Ratings

Voltage (60 Hz)	110V	220V
Max. Cont. Current (amps)	3.0	1.5
Min. Cont. Current (amps)	0.2	0.1

Thermistor (option)

Leads for thermistors are identified as P3 and P4. Thermistors require connection to Texas Instruments® Control Module Model 32AA or its equivalent for proper operation. This item may be purchased from Lincoln - see LC100 catalog.

Brake (option)

Carefully read and fully understand the instructions supplied by the brake manufacturer (see inside of brake housing or separately enclosed sheet). Contact the brake manufacturer for additional information.

GROUNDING

⚠ WARNING



ELECTRIC SHOCK can kill.

- **Connect the motor frame to a good earth ground per the National Electrical Code and local codes to limit the potential to ground in the event of contact between live electrical parts and the metal exterior.**

Lincoln motors may be electrically connected to earth ground using a terminal box mounting screw or a separate grounding screw when provided. Both are accessible inside the mounted terminal box. When a bronze mounting screw is supplied, always use it as the grounding point. In making the ground connection, the installer should make certain that there is a good electrical connection between the grounding lead and the motor.

6. OPERATION

Three phase squirrel cage induction motors will operate successfully, but not necessarily in accordance with nameplate ratings, at voltages 10 percent above or below nameplated value at the design frequency.

⚠ WARNING



MOVING PARTS can injure.

- **Before starting the motor, remove all unused shaft keys and loose rotating parts to prevent them from flying off and causing bodily injury.**
- **Keep away from moving parts.**



ELECTRIC SHOCK can kill.

- **Do not operate with covers removed.**
- **Do not touch electrically live parts.**

After checking that the shaft key is secure, operate the motor free of load and check the direction of rotation. If the motor rotates in the wrong direction, interchange any two supply leads.

Couple the motor to its load and operate it for a minimum of one hour. During this period, check for any unusual noise or thermal conditions. Check the actual operating current to be sure that the nameplate current times service factor is not exceeded for steady continuous loads.

7. MAINTENANCE

⚠ WARNING



ELECTRIC SHOCK can kill.

- **Internal parts of the motor may be at line potential even when it is not rotating.**
- **Disconnect all input power to the drive and motor before performing any maintenance.**

Lincoln motors have been designed and manufactured with long motor life expectancy and trouble-free operation in mind.

Periodically inspect the motor for excessive dirt, friction or vibration. Dust may be blown from an inaccessible location using compressed air. Keep the ventilation openings clear to allow free passage of air. Make sure the drain holes in the motors are kept open and the shaft slinger is positioned against the end bracket. Grease or oil can be wiped by using a petroleum solvent.

Overheating of the bearings caused by excessive friction is usually caused by one of the following factors:

1. Bent shaft.
2. Excessive belt tension.
3. Excessive end or side thrust from the gearing, flexible coupling, etc.
4. Poor alignment.

Damaging vibrations can be caused by loose motor mountings, motor misalignment resulting from the settling or distortion of the foundation, or it may be transmitted from the driven machine. Vibration may also be caused by excessive belt or chain tension.

BEARING SYSTEM

Lincoln motors have a high quality, premium design bearing system. Bearing sizes and enclosures are identified on most motor nameplates. The majority are double-shielded, deep-groove ball bearings. Double-sealed ball bearings are used on some motors in frames 56 and 143T thru 145T. A drive-end cylindrical roller bearing is standard on Crusher Duty motors, frames 405T and larger.

Lubrication instructions and/or grease specifications provided on the motor supersede the following information.

In general, the motor's bearing system has sufficient grease to last indefinitely under normal service conditions. For severe or extreme service conditions, it is advisable to add one-quarter ounce of grease to each bearing per the schedule listed in Table 2. Use a good quality, moisture-resistant, polyurea-based grease such as Chevron SRI #2. Lithium based greases are not compatible with polyurea-based greases; mixing the two types may result in the loss of lubrication.

Motors designed for low ambient applications have bearings with special low temperature grease. Use Beacon 325 lithium based grease or equivalent per the appropriate interval in Table 2.

Motors designed for high ambient applications have bearings with special high temperature grease. Use Dow Corning DC44 silicone grease or equivalent per the interval in Table 2 under "Extreme".

Severe Service: Operating horizontally, 24 hours per day, vibration, dirty, dusty, high humidity, weather exposure, or ambient temperatures from 104-130°F (40-55°C).

Extreme Service: Operating vertically, heavy vibration or shock, heavy duty cycle, very dirty or ambient temperatures from 130-150°F (55-65°C).

Table 2 : Bearing Lubrication Intervals

Motor Syn Speed	Motor Horsepower	Service Conditions	
		Severe	Extreme
BALL BEARINGS			
1800 RPM and slower	1/4 to 7-1/2 HP	2 years	6 months
	10 to 40 HP	1 year	3 months
	50 HP and up	6 months	3 months
above 1800 RPM	all sizes	3 months	3 months
ROLLER BEARINGS			
all speeds	all sizes	3 months	3 months

When adding lubricant, keep all dirt out of the area. Wipe the fitting completely clean and use clean grease dispensing equipment. More bearing failures are caused by dirt introduced during greasing than from insufficient grease.

If the motor is equipped with a relief port or tube, make certain it is open and free of caked or hardened grease. Before replacing relief plugs, allow excess grease or pressure to vent by running the motor for several minutes after lubrication.

⚠ CAUTION

- LUBRICANT SHOULD BE ADDED AT A STEADY MODERATE PRESSURE. IF ADDED UNDER HEAVY PRESSURE BEARING SHIELD(S) MAY COLLAPSE.
- DO NOT OVER GREASE.

PARTS

All parts should be ordered from Authorized Motor Warranty Stations. Call your Lincoln Motors Sales Office for location and phone number. A "Service Directory" listing all Authorized Motor Warranty Stations by geographic location is available; request Bulletin SD-6. These shops stock GENUINE Lincoln replacement parts and have factory trained personnel to service your motor.

8. WHO TO CALL

For the location and phone number of the Lincoln Motors District Sales Office nearest you, check your local Yellow Pages or call 1-800-MOTOR-4-U (1-800-668-6748) or visit our web site at www.lincolnmotors.com.



LINCOLN MOTORS
 Cleveland OH 44117-2525 USA

Tel: 1-800-MOTOR-4-U (668-6748)
 Fax: 1-888-536-6867
 Web: www.lincolnmotors.com
 E-Mail: mailbox@lincolnmotors.com

IM566-A December 1999

9. WARRANTY

Lincoln Motors, the Seller, warrants all new *standard* motors and accessories thereof against defects in workmanship and material provided the equipment has been properly cared for and operated under normal conditions. All warranty periods begin on the date of shipment to the original purchaser. Warranty periods for **low voltage (< 600 V)** motors are defined in the following chart. The warranty period for **medium voltage (> 600 V)** motors is one year on sine-wave power. Contact Lincoln for warranty period on PWM power.

Model Number Prefix	Efficiency Code(s)	Frame Sizes	Warranty Period	
			Sine-Wave Power	PWM Power
AA, AF, AN	S, P, B	143T-286T	5 Yrs	2 Yrs*
CF, SD	M	143T-215T	2 Yrs	1 Yr
CF, CN, CS, CP	E, H, P, B	143T-449T	5 Yrs	2 Yrs*
		182U-449U	5 Yrs	2 Yrs*
C5, C6	H, P	M504-689	3 Yrs	Contact Lincoln #
MD, SE	S	284T-445T	5 Yrs	1 Yr
RC, RJ, SC	H	56-145T	5 Yrs	2 Yrs*
RD, RF	S	56-56H	5 Yrs	2 Yrs*
REW, SEW	S	56-256T	1 Yr	1 Yr
SD, SF	S, H, P, B	143T-449T	5 Yrs	2 Yrs*
Field Kits and Accessories			5 Yrs	

* Applies to motors with a service factor of 1.15 or higher. Motors with a 1.0 service factor have a 1 year warranty on PWM power.

If the Buyer gives the Seller written notice of any defects in equipment within any period of the warranty and the Seller's inspection confirms the existence of such defects, then the Seller shall correct the defect or defects at its option, either by repair or replacement F.O.B. its own factory or other place as designated by the Seller. The remedy provided the Buyer herein for breach of Seller's warranty shall be exclusive.

No expense, liability or responsibility will be assumed by the Seller for repairs made outside of the Seller's factory without written authority from the Seller.

The Seller shall not be liable for any consequential damages in case of any failure to meet the conditions of any warranty. The liability of the Seller arising out of the supplying of said equipment or its use by the Buyer, whether on warranties or otherwise, shall not in any case exceed the cost of correcting defects in the equipment in accordance with the above guarantee. Upon the expiration of any period of warranty, all such liability shall terminate.

The foregoing guarantees and remedies are exclusive and except as above set forth there are no guarantees or warranties with respect to accessories or equipment, either expressed or arising by option of law or trade usage or otherwise implied, including with limitation the warranty of merchantability, all such warranties being waived by the Buyer.

- indicates change since last printing.



APPENDIX VI

**Denison Pump Manual
Premier Series P07**

DENISON HYDRAULICS
open circuit piston pumps
Premier series P07 & 110 C-mod.

service information

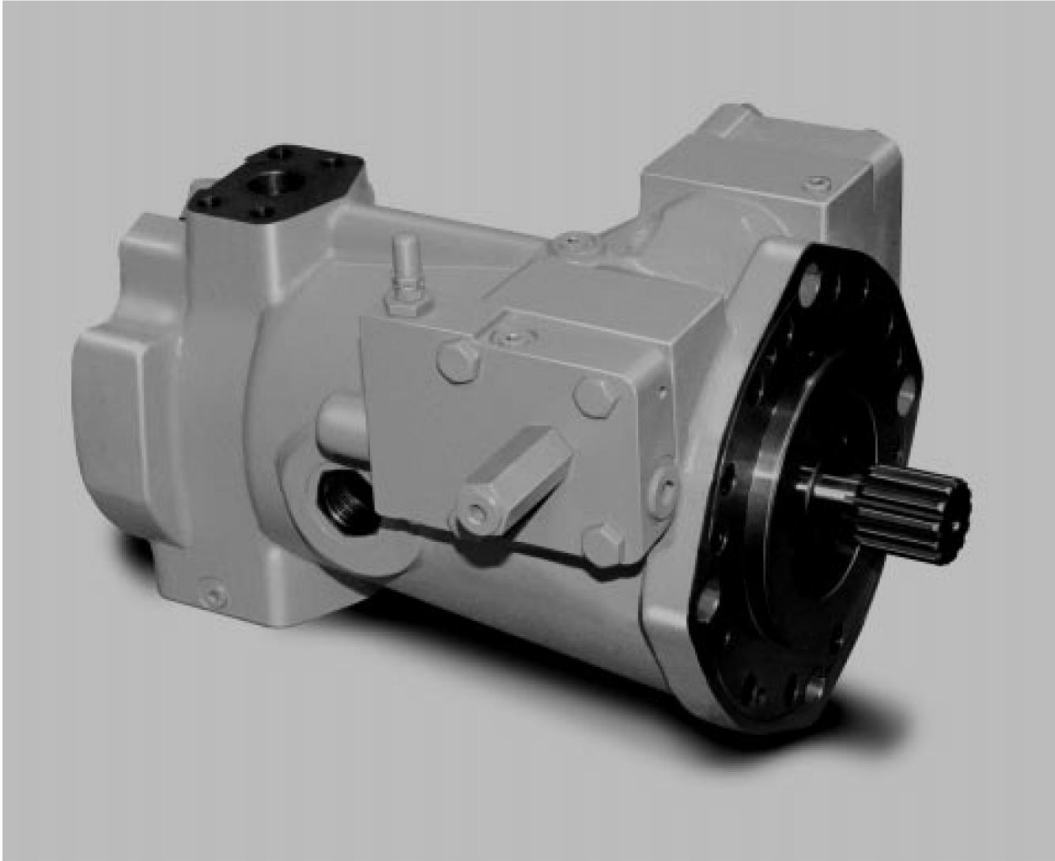

Publ. LT2-00038-2 replaces S1-AM0018

Revised 5/03



Internet <http://www.denisonhydraulics.com> E-mail: denison@denisonhydraulics.com

CONTENTS

TITLE	PAGE
Port Identification	3
Start up Procedure	7
Trouble shooting charts	8
Disassembly	10
Rework limits	11
Parts list	12
Rear drive adapters	16
Conversion	17
Reassembly	18
Controls	25
Pressure compensator.....	27
Maximum Volume Stop; Handwheel.....	30
Buck-up cap assembly	31
Torque limiter	32
Load sensing control.....	36
Load sensing torque limiter	39
Rotary servo	43
Hydraulic stroker	47
Electrohydraulic stroker	50
PQ control (pending).....	54
Control tubing; Control cap	58
Compensator override control	59
Torque limiter override control	61
Testing	64
Rotary servo test	64
Compensator test	66
Load sensing test.....	67
Hydraulic stroker test	68
Electrohydraulic stroker test.....	69
Torque limiter and torque limiter override test	70
Load sensing torque limiter test.....	72
PQ control test (pending)	74
Pump test	75
Tools	76
Characteristics	77
Ordering code	79

Seal kit	P07	S22-15646-0
.....	P110	S22-15647-0

The shaft seal and all "O" rings necessary for total seal replacement may be obtained by ordering Seal Kit . These seals are suitable for petroleum base fluids. For fire resistant fluids contact DENISON HYDRAULICS, Inc. or their authorized distributors to obtain the appropriate seal kit number.

"The product information specifications and descriptions contained in this catalog have been compiled for the use and convenience of our customers from information furnished by the manufacturer, and we cannot and do not accept any responsibility for the accuracy or correctness of any description, calculation, specification or information contained herein. No such description, calculated, specified or information regarding the products being sold has been made part of the basis of the bargain nor has same created or amounted to an express warranty that the products would conform thereto. We are selling the goods and merchandise illustrated and described in this catalog on an as is basis and disclaim any implied warranty, including any warranty of merchantability or warranty of fitness for any particular purposes whatsoever, with respect to the goods and merchandise sold. All manufacturer warranties shall be passed on to our customers, but we shall not be responsible for special, indirect, incidental or consequential damages resulting from the use of any of the products or information contained or described in the catalog."

IDENTIFICATION OF PORTS AND ADJUSTMENTS

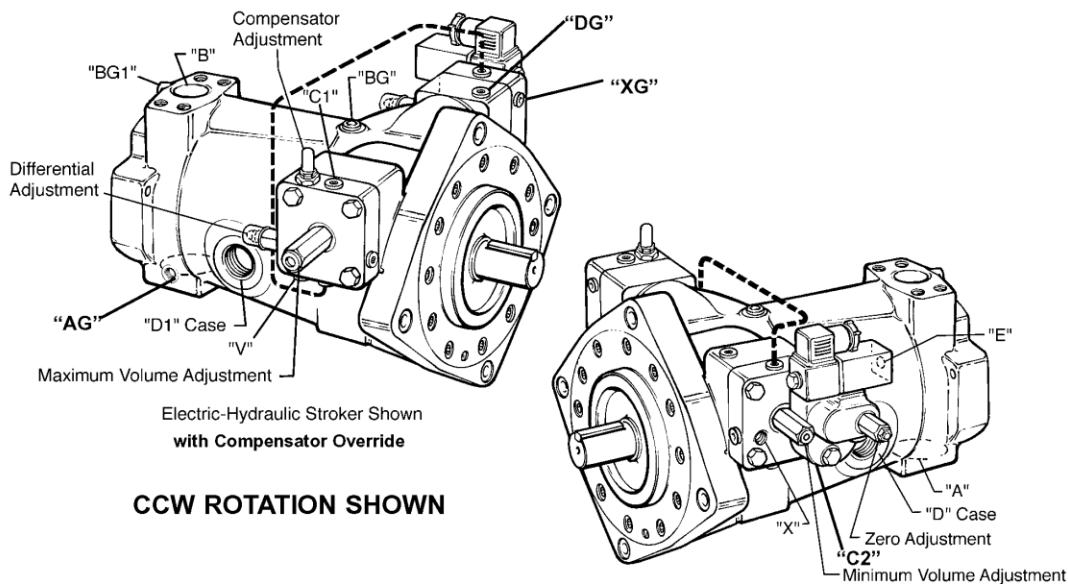

CCW ROTATION SHOWN

FLUID CONNECTIONS

DESCRIPTION	P07	P110
PORT AINLET	3" SAE CODE 61 5/8-11 SCREWS	3" SAE CODE 61 M16-2 SCREWS
PORT BSYSTEM	1-1/4" SAE CODE 62 1/2-13 SCREWS	1-1/4" SAE CODE 62 M14-2 SCREWS
PORT C1OFF-STROKE CYLINDER GAGE.....	SAE-4	1/4 BSPP
PORT C2ON-STROKE CYLINDER. GAGE	SAE-4	1/4 BSPP
PORT DCASE DRAIN	SAE-16	1 BSPP
PORT D1CASE DRAIN	SAE-16	1 BSPP
PORT DG.....DRAIN GAGE, AIR BLEED PORT	SAE-4	3/8 BSPP
PORT AG.....INLET GAGE	SAE-4	1/4 BSPP
PORT BG.....SYSTEM GAGE.....	SAE-4	1/4 BSPP
PORT BG1....ALTERNATE SYSTEM GAGE	SAE-6	1/4 BSPP
PORT EELECTROHYDRAULIC STROKER SERVO SUPPLY	SAE-4	1/4 BSPP
PORT HHYDRAULIC STROKER SIGNAL.....	SAE-4	1/4 BSPP
PORT LSLOAD SENSING LINE	SAE-4	1/4 BSPP
PORT VCOMPENSATOR, TORQUE LIMITER, LOAD SENSING VENT	SAE-8	3/8 BSPP
PORT V1SERVO VENT	SAE-4	1/4 BSPP
PORT XSERVO SUPPLY	SAE-6	3/8 BSPP
PORT XG.....SERVO GAGE	SAE-10	1/2 BSPP

PRIMARY CONTROLS

CLOCKWISE
ROTATION

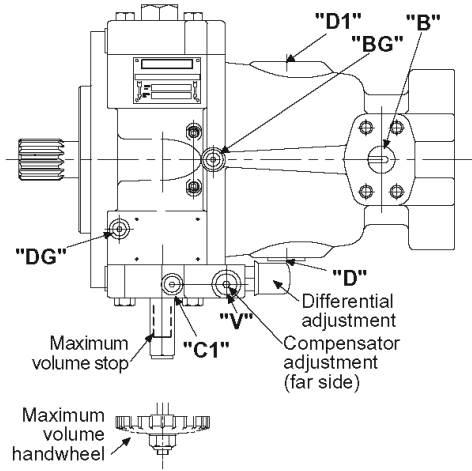

COUNTERCLOCKWISE
ROTATION

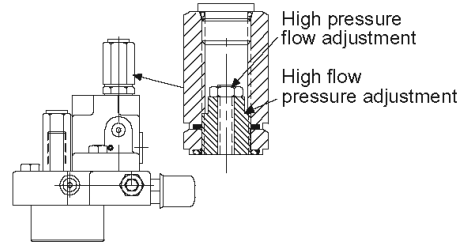
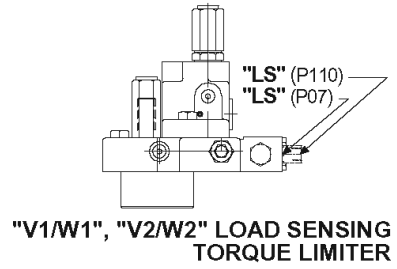

"J1/K1", "J2/K2" TORQUE LIMITER

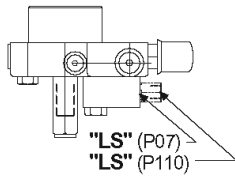

"L1", "L2" LOAD SENSING

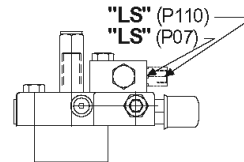

"L1", "L2" LOAD SENSING

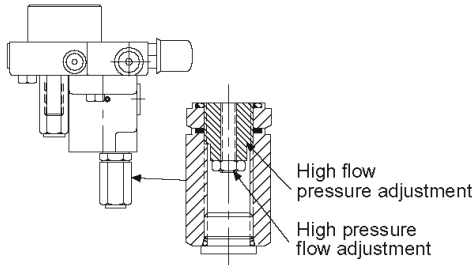

"J1/K1", "J2/K2" TORQUE LIMITER

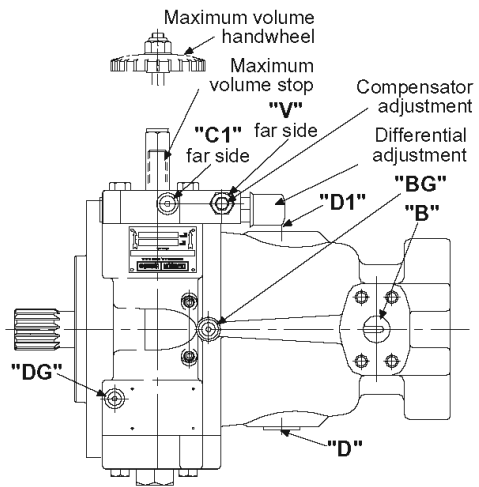

"C1", "C2" COMPENSATOR

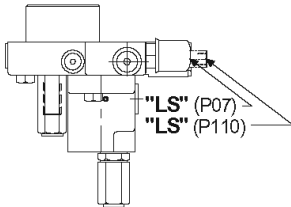

"V1/W1", "V2/W2" LOAD SENSING
TORQUE LIMITER

PRIMARY CONTROLS

CLOCKWISE
ROTATION

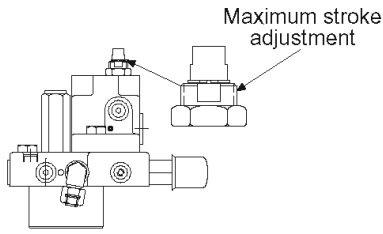

"R" ROTARY SERVO

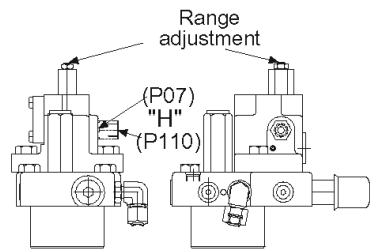

"H" HYDRAULIC STROKER

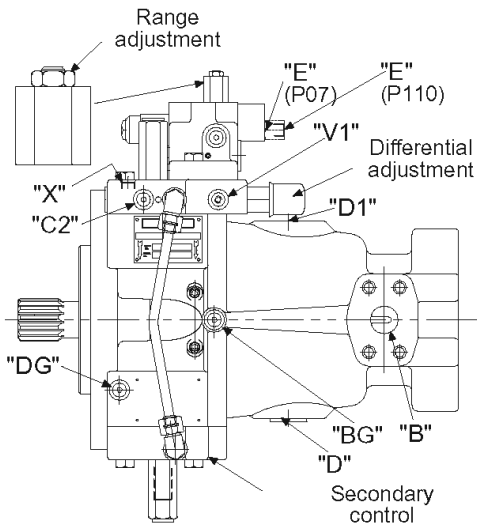

"E" ELECTROHYDRAULIC STROKER

COUNTERCLOCKWISE
ROTATION

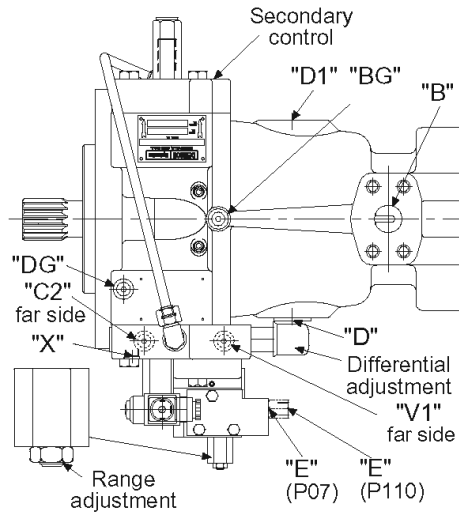

"E" ELECTROHYDRAULIC STROKER

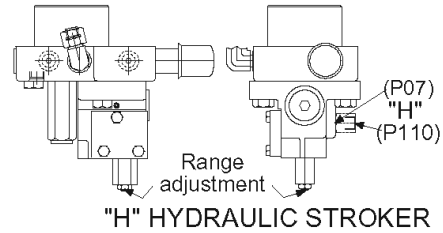

"H" HYDRAULIC STROKER

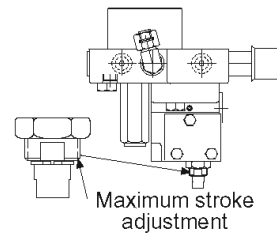

"R" ROTARY SERVO

SECONDARY CONTROLS

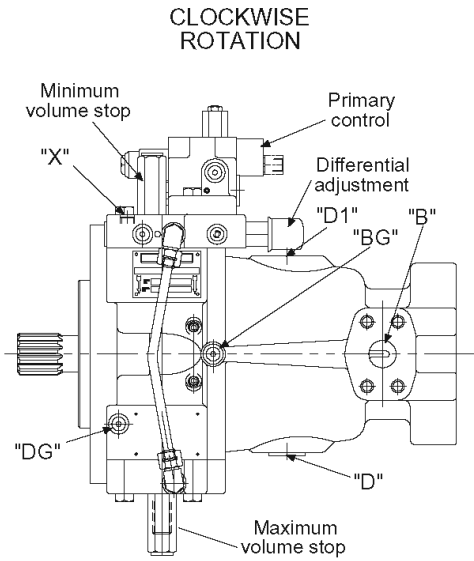

"*10"
CONTROL CAP WITH
MAXIMUM VOLUME STOP

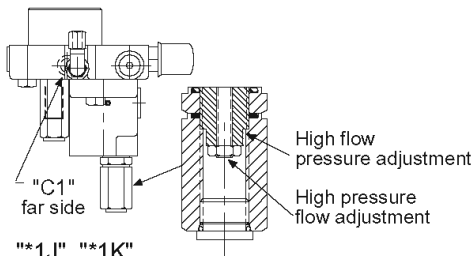

"*1J", "*1K"
TORQUE LIMITER OVERRIDE WITH
MAXIMUM VOLUME STOP

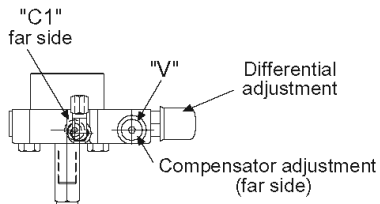

"*1P"
COMPENSATOR OVERRIDE WITH
MAXIMUM VOLUME STOP

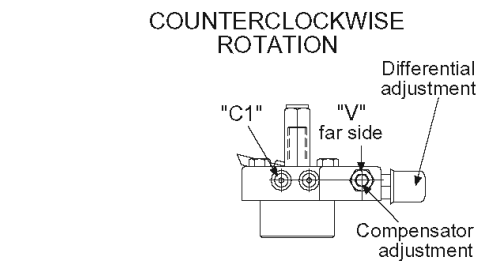

"*1P"
COMPENSATOR OVERRIDE WITH
MAXIMUM VOLUME STOP

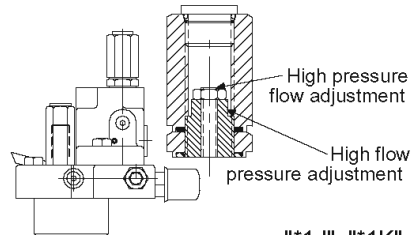

"*1J", "*1K"
TORQUE LIMITER OVERRIDE WITH
MAXIMUM VOLUME STOP

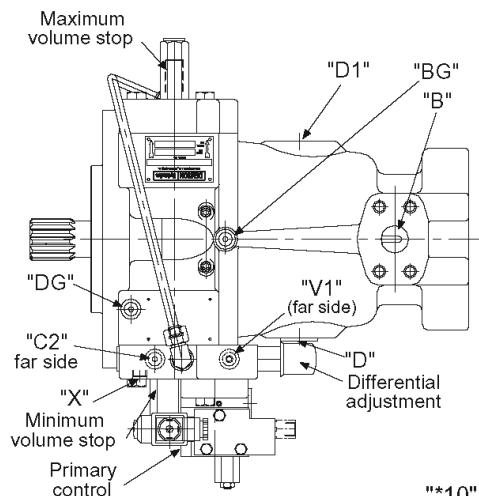

"*10"
CONTROL CAP WITH
MAXIMUM VOLUME STOP

START UP

START UP PROCEDURE FOR NEW INSTALLATION

- Read and understand the instruction manual. Identify components and their function.
- Visually inspect components and lines for possible damage.
- Check reservoir for cleanliness. Drain and clean as required
- Check fluid level and fill as required with filtered fluid at least as clean as that recommended. Fill pump case with clean oil prior to starting. If pump is mounted vertically with shaft up, bleed air from case by removing plug from port "DG" till fluid runs clear.
- Check alignment of drive.
- Check oil cooler and activate it, if included in circuit. Check fluid temperature
- Reduce pressure settings of compensator and relief valve. Make sure accurate pressure readings can be made at appropriate places.
- If solenoids are in system, check for actuation.
- Start pump drive. Observe for correct shaft rotation. Make sure pump fills properly.
- Bleed system of air. Recheck fluid level.
- Cycle unloaded machine at low pressure and observe actuation (at low speed, if possible).
- Increase pressure settings gradually in steps. Check for leaks in all lines, especially in pump inlet lines.
- Make correct pressure adjustments.
- Gradually increase speed. Be alert for trouble as indicated by changes in sounds, system shocks and air in fluid.
- Equipment is operational.

TROUBLESHOOTING

Component problems and circuit problems are often interrelated. An improper circuit may operate with apparent success but will cause failure of a particular component within it. The component failure is the effect, not the cause of the problem. This general guide is offered to help in locating and eliminating the cause of problems by studying their effects.

Effect of Trouble	Possible Cause	Fault Which Needs Remedy
pump noisy	air in system	leak in suction line. low fluid level. turbulent fluid. return lines above fluid level. gas leak from accumulator. excessive pressure drop in the inlet line from a pressurized reservoir. suction line strainer acting as air trap.
	cavitation in rotating group.	fluid too cold, too viscous, or too heavy. shaft speed too high. suction line strainer too small, or strainer too dirty. operating altitude too high. boost pressure too low. inlet flow too small for dynamic conditions.
	misaligned shaft.	faulty installation. distortion in mounting. axial interference. faulty coupling. excessive overhung loads.
	mechanical fault in pump.	piston and shoe looseness or failure. bearing failure. incorrect port plate selection or index. eroded or worn parts in the displacement control.
erosion on barrel ports and port plate.	air in fluid. cavitation.	see noisy pump above. see noisy pump above.
high wear in pump.	excessive loads.	reduce pressure settings. reduce speeds.
	contaminant particles in fluid.	improper filter maintenance. filters too coarse. introduction of dirty fluid to system. reservoir openings. improper reservoir breather. improper line replacement.
	Improper fluid.	fluid too thin or thick for operating temperature range. breakdown of fluid with time/temperature/shearing effects. incorrect additives in new fluid. destruction of additive effectiveness with chemical aging
	improper repair.	incorrect parts, procedures, dimensions, finishes.
	unwanted water in fluid.	condensation. faulty breather/strainer. heat exchanger leakage. faulty clean-up practice. water in makeup fluid.
pressure shocks.	cogging load. worn relief valve. worn compensator. slow response in check valves.	mechanical considerations. needed repairs. needed repairs. replace or relocate.
	excessive decompression energy rates.	improve decompression control.
	excessive line capacitance. (line volume, line stretch, accumulator effects).	reduce line size or lengths. eliminate hose.
	barrel blow-off.	re-check pump holddown, rotating group, drain pressure.
heating of fluid.	excessive pump leakage.	recheck case drain flow and repair as required. fluid too thin. improper assembly, port timing.
	relief valve.	set too low (compared to load or to compensator). instability caused by back pressure, worn parts.
	compensator.	set too high (compared to relief). worn parts.
	pump too large for fluid needs.	select smaller pump displacement.
	heat exchanger.	water turned off, too hot or too little flow. fan clogged or restricted. efficiency reduced by mud or scale deposits. intermittent hydraulic fluid flow.
	reservoir.	too little fluid. improper baffles. insulating air blanket that prevents heat rejection. heat pickup from adjacent equipment..

TROUBLESHOOTING

Effect of Trouble	Possible Cause	Fault Which Needs Remedy
Compensator, Compensator Override Low system pressure	Compensator malfunction	Dirt in spool orifice Damaged cone or seat Broken differential spring Improperly adjusted differential spring
Failure to compensate	Differential adjustment	Differential set too high
Sluggish response	Differential adjustment	Differential set too low
Wide pressure fluctuations (hunting)	Excessive line capacitance	Install check valve near pump outlet
Load Sensing Control Low system pressure	Compensator malfunction	Dirt in spool orifice Damaged cone or seat Broken differential spring Improperly adjusted differential spring
Failure to compensate	Differential adjustment	Differential set too high
Sluggish response	Differential adjustment Modulating valve	Differential set too low Air in load sensing line
Wide pressure fluctuations (hunting)	Excessive line capacitance Modulating valve	Install check valve near pump outlet Air in load sensing line
Excessive pressure drop across control valve	Differential adjustment	Differential set too high
Poor control of flow	Differential adjustment	Differential set too low
Torque Limiter, Torque Limiter Override Torque setting erratic	Torque limiter cap malfunction	Sticking pin
Torque incorrect at high flows	Incorrect torque setting	Outer adjustment screw
Torque incorrect at low flows	Incorrect torque setting	Inner adjustment screw
Too much torque variation	Wrong torque limiter for range	Replace inner/outer springs with correct springs
Low system pressure	Compensator malfunction	Dirt in spool orifice Damaged cone or seat Broken differential spring Improperly adjusted differential spring
Failure to compensate	Differential adjustment	Differential set too high
Sluggish response	Differential adjustment	Differential set too low
Wide pressure fluctuations (hunting)	Excessive line capacitance	Install check valve near pump outlet
Rotary Servo Failure to stroke	Differential adjustment	Differential set too low
Goes to full	Differential adjustment	Differential set too high
Sluggish response	Low servo pressure	Check servo pressure
Strokes in steps	Servo cap malfunction	Sticking pin Wear on linkages or input cam surface
Hydraulic Stroker Failure to stroke	Differential adjustment	Differential set too low
Goes to full	Differential adjustment	Differential set too high
Strokes in steps	Servo cap malfunction	Wear on linkages, Sticking stroker piston
Electric Stroker Failure to stroke	Differential adjustment	Differential set too low
Goes to full	Differential adjustment	Differential set too high
Excessive hysteresis	Electric proportional valve	Change dither on electrical signal
No response	Electric proportional valve	Faulty wiring, Filter screen plugged
Strokes in steps	Servo cap malfunction	Wear on linkages Sticking stroker piston
Instability	Air in control	Bleed air from control Check for air in servo supply

DISASSEMBLY INSTRUCTIONS

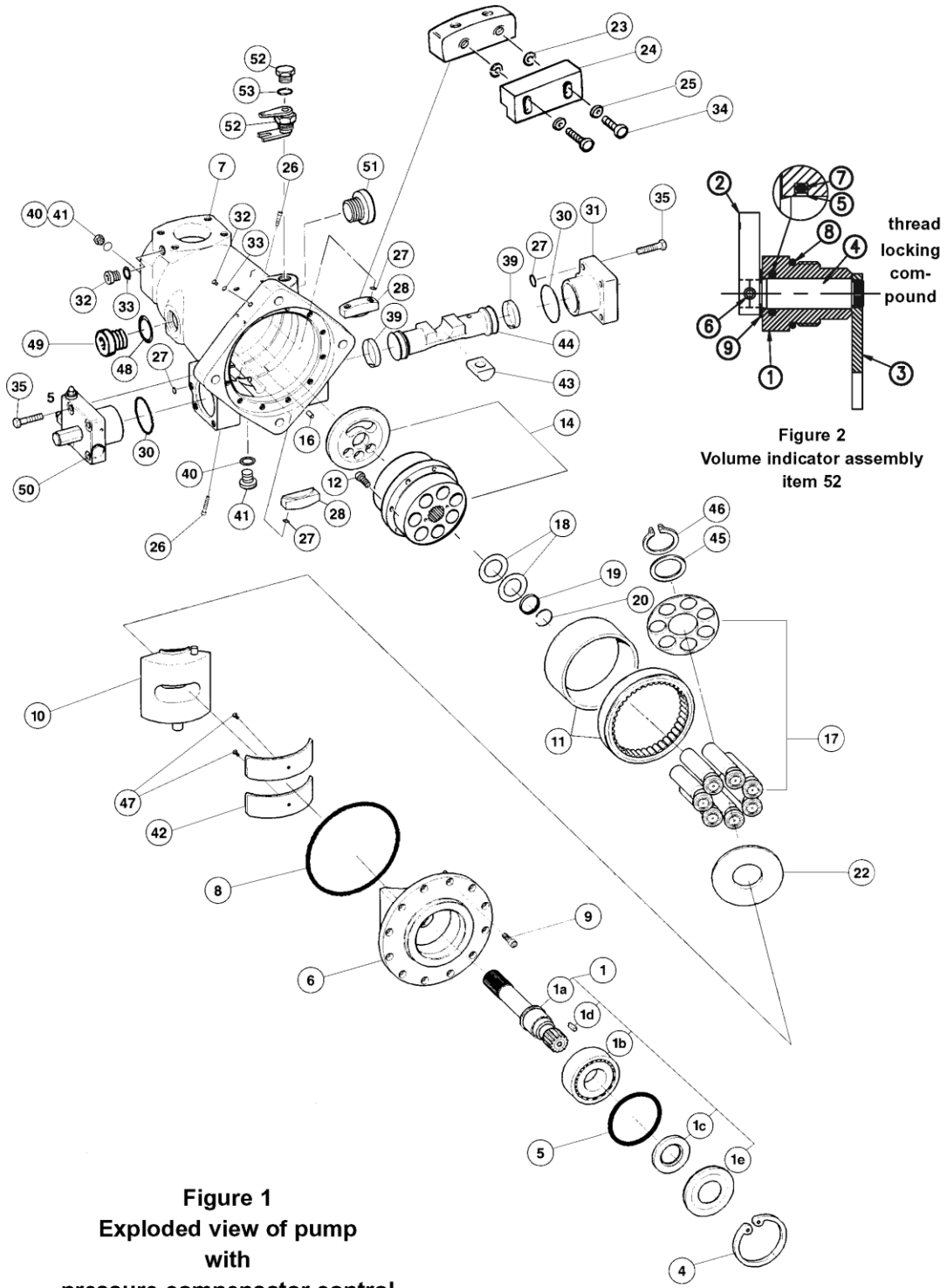

Figure 1
Exploded view of pump
with
pressure compensator control

DISASSEMBLY INSTRUCTIONS

Disassembly

Disassemble only as far as necessary to replace or repair worn parts.

If the pump has a rear drive, the mounting adapter and coupling must be removed prior to pump disassembly *Refer to figure 3 page 16.*

Clean outside surface of the pump before disassembly. Disassembly area should be clean. A suitable surface should be used capable of supporting the pump weight of 177 lbs, 80,3 Kg.

Refer to illustration, see figure 1 and 2

1. Remove plug (49) and drain oil from pump. Position pump with shaft up.
2. Wind maximum volume screw CW (ref item (50), item 1 page 27) so that piston (44) bottoms out. This positions the cam at approximately zero displacement allowing removal of the drive shaft.
3. Remove socket head cap screws (9). If disassembling PQ Control version, remove tubing and pass thru fitting (56).
4. Remove cradle assembly (6) from the housing. The threaded hole in end of the shaft is provided for lifting this assembly. Threaded hole is 3/8-16 for P07, M10 for ISO and M12 for DIN shaft.
5. Remove snap ring (4).
6. Remove screws (47) to remove cam bearing (42).
7. Remove shaft (1), bearing, and seal retainer. Support flat face of the rocker cradle and press end of shaft opposite the bearing end.
8. Remove the shaft seal (1c) from the retainer (1e) if necessary.
9. Remove retaining ring (20).
10. Press bearing off shaft if necessary. Press against bearing inner race.
11. If pump contains a volume indicator assembly (52): *Refer to Figure 2:* Remove indicator pointer (2), retaining ring (9) and pivot nut (1) from pump housing. Remove pivot shaft and fork assembly (3) and (4) through the hole.
11. Remove two screws (34), two washers (25), clearance bearing (24), and two washers (23) from retainer (28).
12. Wind maximum volume screw CCW until piston (44) bottoms out.
13. Remove control cap (50) and control cap (31). (*Refer to controls section for control disassembly*).
14. The piston must be moved outward (away from pump center) to remove cam assembly.
15. Lift cam assembly (10) from pump. (Link (43), pistons and shoes and retainer plate(17), wear plate (22), and hold-down (45 and 46) are part of the cam assembly.)
16. Remove slide link (43), retaining ring (45), thrust washer (46), pistons, shoes & retainer assembly (17) and wear plate (22). The pins for the slide link and for the indicator have been pressed into the rocker cam and should not be removed.
17. Remove two screws (26), and two retainers (28).
18. Remove Belleville washers (18) and barrel stop (19).
19. Attach tool (T-1) (pg. 76) to barrel assembly (14-1). (Two M6 screws are required.) Lift barrel from port plate and housing.
20. The inner race of bearing (11) has a light press fit with barrel. Do not remove the inner race unless bearing needs to be replaced. If replacement is necessary, remove seven socket head cap screws (12). Replace with 5/16-18 UNC x 6 1/2 in. long soc hd cap screws. Rest assembly on the extended screws. Press barrel from inner race. Care must be taken to avoid damage to barrel face.
21. Remove port plate ref. see item (14), and alignment pin (16), from port block.

The barrel bearing outer race (11) should only be removed from housing if worn, damaged or closer inspection is needed. A bearing puller should be used for removal.

REWORK LIMITS OF WEAR PARTS

item	maximum rework from original dimension	minimum dimension after rework
wear plate	.005", 0,127 mm	.184", 4,674 mm
piston shoe face(pocket)	*	.4175", 10,605 mm

*shoe face pocket depth must be .004", 0,10 mm minimum

WEAR PLATE

The wear plate finish must be 10 μ in., 0,25 μ m minimum, flat within .0005", 0,0127 mm and parallel to the backside within .001", 0,0254 mm total indicator reading.

PISTON SHOE

The piston shoe wear face finish must be 45 μ in., 1,143 μ m min, and must be lapped in a set with the retainer plate. All shoe sole thicknesses to be within .001", 0,0254 mm after lapping. The maximum permissible shoe and piston axial looseness is .010", 0,254 mm.

PUMP PARTS LISTS

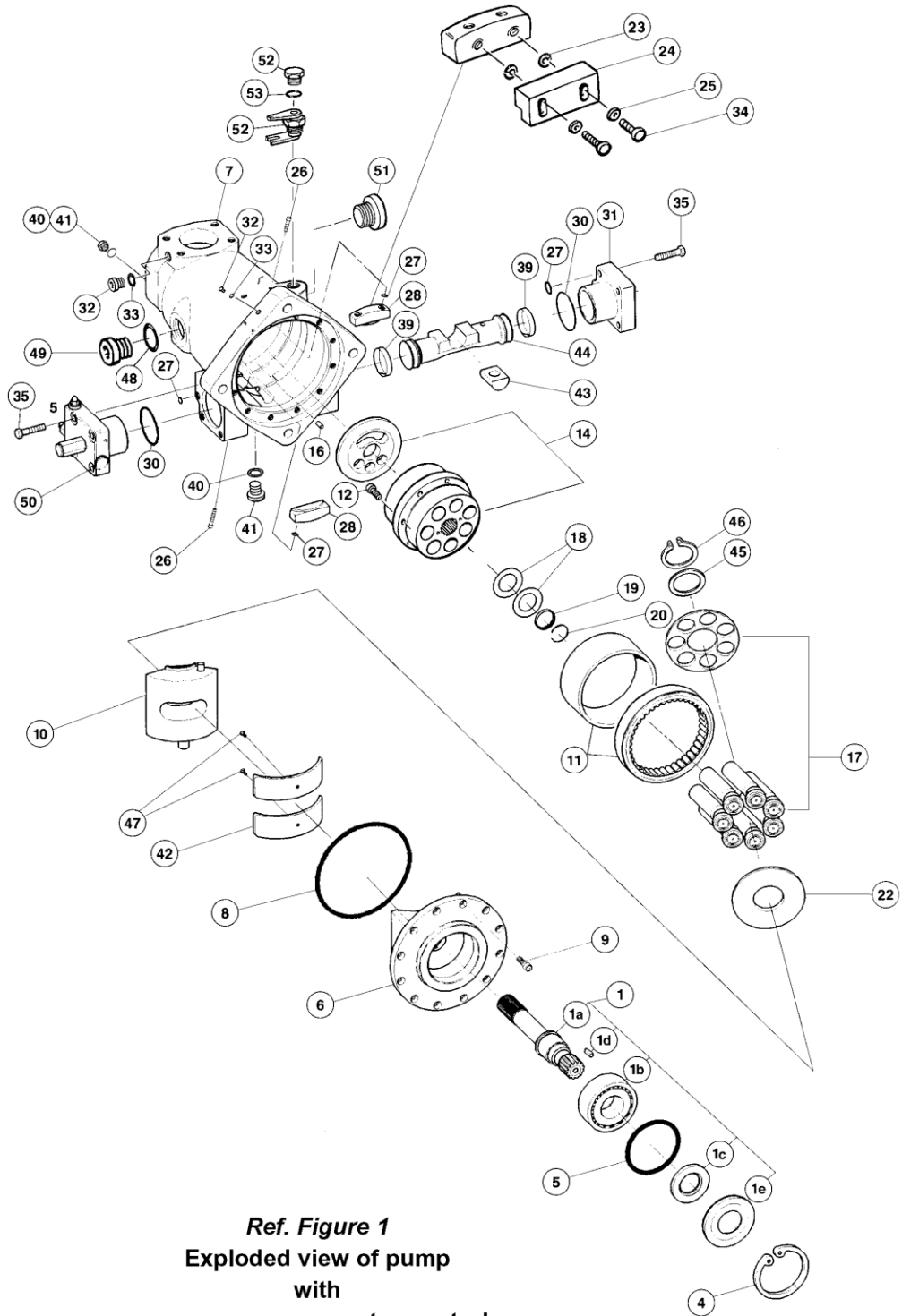

Ref. Figure 1
Exploded view of pump
with
pressure compensator control

PUMP PARTS LISTS

item	description	part no. P07-SAE	part no. P110-ISO	qty.
1	shaft assembly			1
	keyed, no rear drive	S22-15337	S22-15598	
	a (shaft)	032-91829	032-92197	
	b (bearing)	230-82216	230-82216	
	c (seal)	620-82080	230-82080	
	d (key)	033-71514	032-91429	
	e (seal retainer)	032-91835	032-91835	
	keyed, with rear drive	S22-16027	S22-16028	
	a (shaft)	032-92525	032-92526	
	b (bearing)	230-82216	230-82216	
	c (seal)	620-82080	230-82080	
	d (key)	033-71514	032-91429	
	e (seal retainer)	032-91835	032-91835	
	splined, no rear drive	S22-15338	S22-15599	
	a (shaft)	032-91828	032-92198	
	b (bearing)	230-82216	230-82216	
	c (seal)	620-82080	230-82080	
	e (seal retainer)	032-91835	032-91835	
	splined, with rear drive	S22-16025	S22-16026	
	a (shaft)	032-92524	032-92527	
	b (bearing)	230-82216	230-82216	
	c (seal)	620-82080	230-82080	
	e (seal retainer)	032-91835	032-91835	
			P110-DIN	
	keyed, no rear drive		S22-15673	
	a (shaft)		032-92255	
	b (bearing)		230-82216	
	c (seal)		620-82080	
	d (key)		032-92246	
	e (seal retainer)		032-91835	
	keyed, with rear drive		S22-16030	
	a (shaft)		032-92529	
	b (bearing)		230-82216	
	c (seal)		620-82080	
	d (key)		032-92246	
	e (seal retainer)		032-91835	
	splined, no rear drive		S22-15602	
	a (shaft)		032-92212	
	b (bearing)		230-82216	
	c (seal)		620-82080	
	e (seal retainer)		032-91835	
	splined, with rear drive		S22-16029	
	a (shaft)		032-92528	
	b (bearing)		230-82216	
	c (seal)		620-82080	
	e (seal retainer)		032-91835	
4	retainer	356-65086	356-65086	1
5	O-ring, 70 S-1 ARP 155	671-00155	671-00155	1
6	cradle	032-92446	032-92477	1
7	housing, no rear drive	032-92473	032-92579	1
	housing, with rear drive	032-92481	032-92580	
8	O-ring, 70 S-1 ARP 263	671-00263	671-00263	1
9	screw, SHC	361-11213	361-11213	14
10	cam assembly	S22-15903	S22-15903	1
11	bearing	032-92449	032-92449	1
12	screw, SHC	361-10234	361-10234	7
14	barrel & port plate assembly CW	S22-16145	S22-16145	1
	barrel & port plate assembly CCW	S22-16146	S22-16146	

PUMP PARTS LISTS

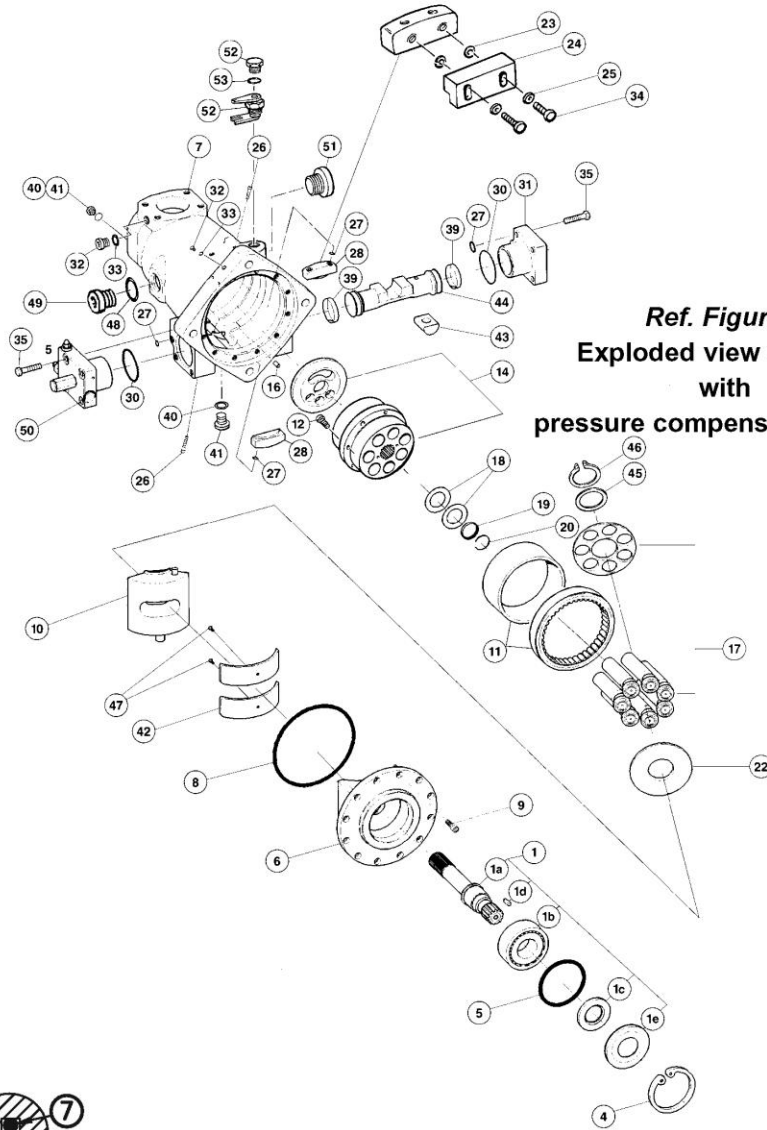

Ref. Figure 1
Exploded view of pump
with
pressure compensator control

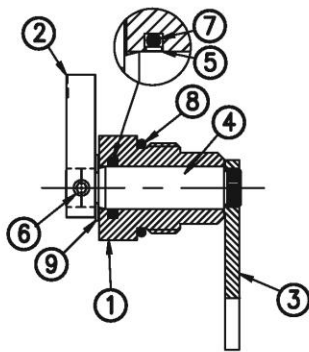

Ref. figure 2
Indicator Assembly (52)
S22-16262

PARTS LIST FOR INDICATOR ASSEMBLY

item	description	part no.	qty.
1	Pivot nut	032-92491	1
2	Indicator	033-70624	1
3	fork	032-92653	1
4	pivot shaft	032-92492	1
5	glyd ring	679-00030	1
6	Soc. setscrew, 10-32 x 3/16	312-09030	1
7	O-ring, 70 S-1 ARP 114	671-00114	1
8	O-ring, 90 S-1 ARP 914	691-00914	1
9	Retaining ring	356-65070	1

PUMP PARTS LISTS

item	description	part no. P07-SAE	part no. P110-ISO	qty.
16	dowel pin	324-21610	324-21610	1
17	pistons, shoes,retainer assembly	S22-16039	S22-16039	1
	(17-1) retainer plate (1 req'd)	032-92453	032-92453	
	(17-2) pistons and shoes (7 req'd)	S22-16031	S22-16031	
18	Belleville washer	032-91827	032-91827	2
19	stop	032-91824	032-91824	1
20	retaining ring	032-91825	032-91825	1
22	wear plate	032-92452	032-92452	1
23	lockwasher	348-10016	348-10016	2
24	bearing	032-91602	032-91602	1
25	washer	345-10012	345-10012	2
26	screw, SHC	361-08200	361-08200	4
27	O-ring, 90 S-1 ARP 013	691-00013	691-00013	6
28	cam/bearing retainer	032-92470	032-92470	2
30	O-ring, 70 S-1 ARP151	671-00151	671-00151	2
31	off stroke control side (see page 17)			1
	buck-up cap (comp, torque limiter, load sensing)	S22-15447	S22-15447	
	electric stroker	S22-16204	S22-16203	
	hydraulic stroker	S22-16202	S22-16201	
	rotary servo	S22-16200	S22-16199	
32	plug	488-35061	447-00032	2
33	O-ring, 90 S-1 ARP 904	691-00904	none	3
34	screw, SHC	361-08704	361-08704	2
35	Screw, HHC, M12 x 1,75 x 55 mm lg.	363-12205	363-12205	*
	Screw, HHC, M12 x 1,75 x 75 mm lg.(E,H,R,J,K)	363-12220	363-12220	*
	Screw, HHC, M12 x 1,75 x 85 mm lg. (L)	363-12233	363-12233	*
39	ring (qty. 1 for servo, electric & hydraulic stroker)	032-91816	032-91816	2
	ring (servo, electric & hydraulic stroker)	032-91811	032-91811	1
40	O-ring, 90 S-1 ARP 906	691-00906	none	2
41	plug	488-35041	447-00032	2
42	bearing	032-92454	032-92454	2
43	slide link	032-91823	032-91823	1
44	control piston (compensator, torque limiter)	032-91836	032-91836	1
	control piston (servo, electric & hydraulic stroker)	032-91848	032-91848	
45	bearing	032-91830	032-91830	1
46	retainer, white, .062", 1,57 mm thick	032-91853	032-91853	1
	retainer, red, .064", 1,63 mm thick	033-91854	033-91854	
	retainer, green, .067", 1,70 mm thick	033-91855	033-91855	
	retainer, yellow, .069", 1,75 m thick	033-91856	033-91856	
	retainer, blue, .071", 1,80 mm thick	033-91857	033-91857	
47	screw, FSHCS	316-50001	316-50001	2
48	O-ring, 90 S-1 ARP 916	691-00916	none	1
49	plug	488-35024	447-01016	1
50	on stroke control side (see page 17)			1
	compensator (C1)	S22-15394	S22-15623	
	compensator (C2)	S22-15626	S22-15633	
	low torque limiter (J1)	S22-15401	S22-15624	
	low torque limiter (J2)	S22-15627	S22-15634	
	high torque limiter (K1)	S22-15629	S22-15631	
	high torque limiter (K2)	S22-15635	S22-15636	
	load sensing (L1)	S22-15402	S22-15625	
	load sensing (L2)	S22-15628	S22-15637	
	low torque limiter w/load sensing (V1)	S22-16186	S22-16188	
	low torque limiter w/load sensing (V2)	S22-16195	S22-16196	
	high torque limiter w/load sensing (W1)	S22-16187	S22-16189	
	high torque limiter w/load sensing (W2)	S22-16197	S22-16198	
	compensator override	S22-16205	S22-16206	
	low torque limiter override	S22-16207	S22-16208	
	high torque limiter override	S22-16209	S22-16210	
	max. volume screw, servo	S22-15325	S22-15613	
51	shipping plug	449-00019	449-00613	
52	plug	488-35030	488-35030	1
	indicator assembly (see figure 2)	S22-16262	S22-16262	
53	O-ring, 90 S-1 ARP 914	691-00914	691-00914	1

*qty and size depends on control (31) and (50). see controls section, starting pg 25

REAR DRIVE PARTS LISTS

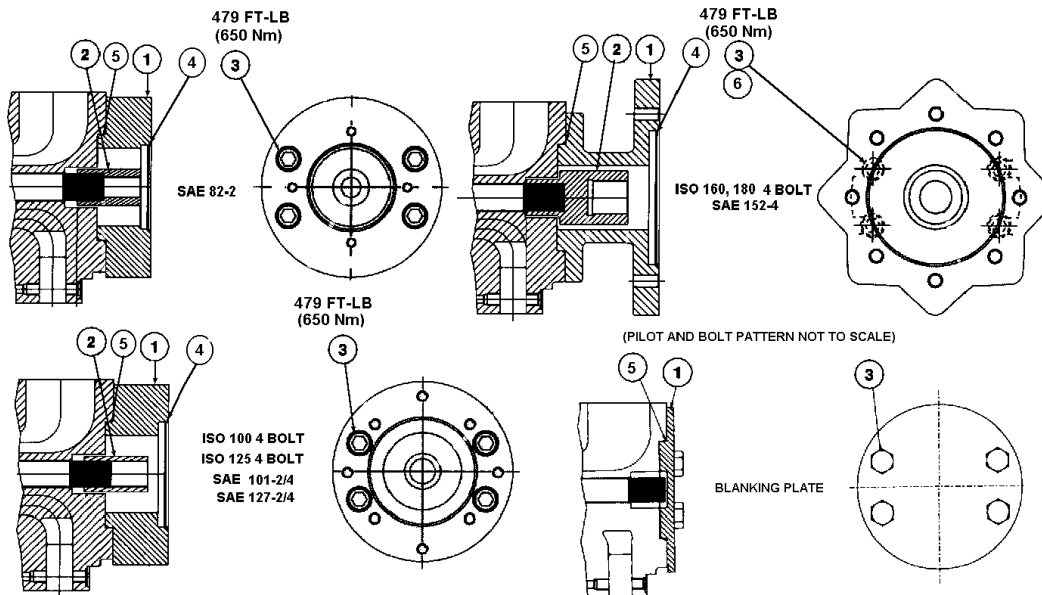

Figure 3

SAE REAR DRIVES									
		code →	A	G	B	Q	C	N	D
		flange →	SAE 82-2	SAE 82-2	SAE101-2/4	SAE101-2/4	SAE127-2/4	SAE127-2/4	SAE152-4
		coupling →	16-4	22-4	22-4	25-4	32-4	38-4	44-4
item	part	qty	("A")	(modified "A")	("B")	("B-B")	("C")	("C-C")	("D")
1	adapter	1	032-91900	032-91900	032-91309	032-91309	032-91308	032-91649	032-91282
2	coupling	1	032-91901	032-92377	032-91361	032-91362	032-91363	032-91648	032-91634
3	screw	4	361-16304-8	361-16304-8	361-16304-8	361-16304-8	361-16304-8	361-16304-8	361-16304-8
4	O-ring	1	671-00152	671-00152	671-00155	671-00155	671-00159	671-00159	671-00163
5	O-ring	1	671-00159	671-00159	671-00159	671-00159	671-00159	671-00159	671-00159
6	washer	4							350-10109-
	assembly		S22-15372	S22-15809	S22-12867	S22-12868	S22-12869	S22-12920	S22-12870

ISO REAR DRIVES								
		code →	Z	Y	X	T	U	L
		flange →	ISO 100	ISO 125	ISO 160	ISO 180	ISO 180	ISO 180
		coupling →	ISO K25N	ISO K32N	ISO K40N	ISO K40N	ISO K50N	DIN 40-18
item	part	qty						
1	adapter	1	032-91383	032-91384	032-91385	032-92162	032-92162	032-92162
2	coupling	1	032-91391	032-91390	032-91389	032-91389	032-91388	032-92345
3	screw	4	361-16304-8	361-16304-8	361-16304-8	361-16304-8	361-16304-8	361-16304-8
4	O-ring	1	671-00155	671-00159	671-00164	671-00167	671-00167	671-00167
5	O-ring	1	671-00159	671-00159	671-00159	671-00159	671-00159	671-00159
6	washer	4			350-10109	350-10109	350-10109	350-10109
	assembly		S22-12872	S22-12873	S22-12874	S22-15740	S22-15570	S22-15933

note: code M item (1) blanking plate part no. 032-91468 item (3) blanking plate screws 363-16210-8

CONVERSION

ROTATION CONVERSION

The following parts and assembly are required for changing shaft rotation:

- A different barrel and port plate assembly is required. The barrel and port plate are matched assemblies, and should not be ordered separately. The reference part numbers are:

CW - Barrel and Port Plate Assembly S22- 16145
CCW - Barrel and Port Plate Assembly S22- 16146

- The control piston must be reversed to position it correctly to the control caps. See step 9 pg. 20
- The control caps location are reversed. **see illustrations below.**

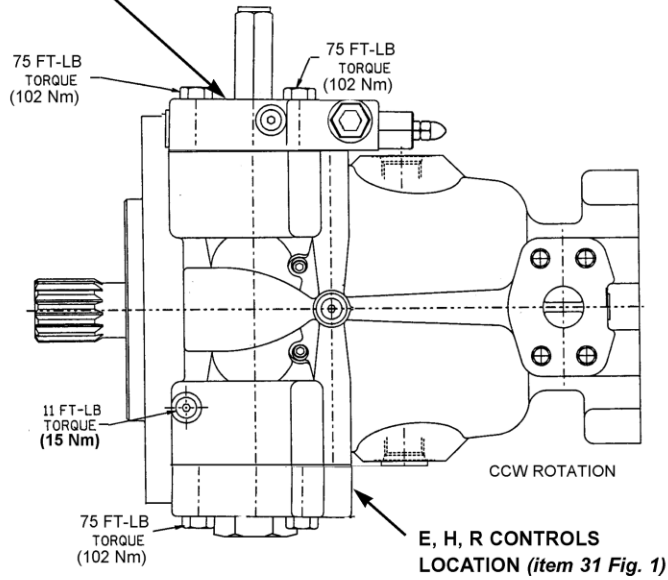
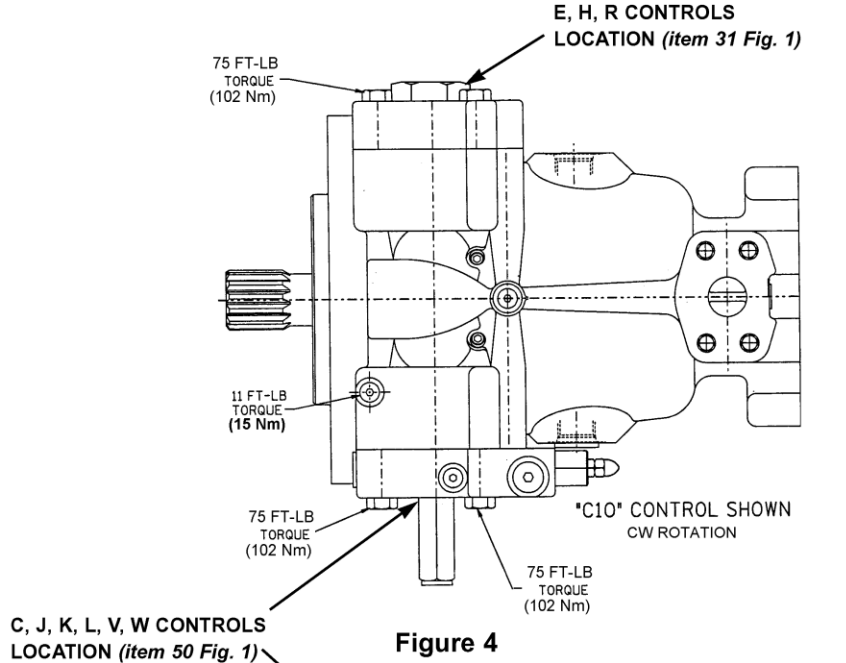

PUMP REASSEMBLY INSTRUCTIONS

SHAFT SEAL REPLACEMENT

See illustration Remove worn or damaged seal from retainer. Clean gasket sealant from retainer.

Install new seal by applying gasket sealant to retainer and pressing seal in retainer.

SEAL KITS P07 S22-15646-0
 P110 S22-15647-0

The shaft seal and all "O" rings necessary for total seal replacement may be obtained by ordering the Seal Kit. These seals are suitable for petroleum base fluids. For fire resistant fluids contact **DENISON HYDRAULICS, Inc.** or their authorized distributors to obtain the appropriate seal kit number.

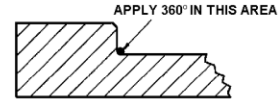

SHAFT ASSEMBLIES (see parts list, item (1) on page 13)

The following assemblies include shaft, key when applicable, bearing and seal:

	P07-SAE #	P110-ISO #
Keyed, no rear drive assembly	S22-15337	S22-15598
Keyed, with rear drive assembly	S22-16027	S22-16028
Splined, no rear drive assembly	S22-15338	S22-15599
Splined, with rear drive assembly	S22-16025	S22-16026
		P110-DIN #
Keyed, no rear drive assembly		S22-15673
Keyed, with rear drive assembly		S22-16030
Splined, no rear drive assembly		S22-15602
Splined, with rear drive assembly		S22-16029

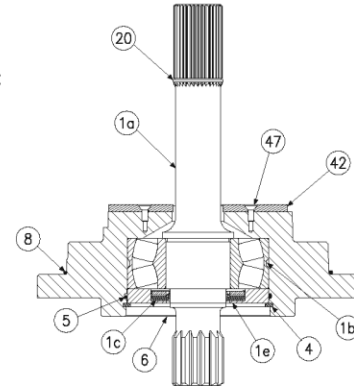

PRE-ASSEMBLY

Depending on the repairs, many steps in this section may not be applicable.

The assembly area should be clean and the environment such that foreign matter will not be introduced to the pump during assembly. All parts must be absolutely clean and free from rust, contamination, lint, or any other foreign matter. Critical surfaces must be free of dings or scratches. All "O" rings and seals must be clean and carefully examined for cuts or other damage before installation.

During assembly, occasional reference will be made to the use of lubricating oil for proper assembly. It is important that any oil used be compatible with the seals and fluid to be used in operation. Compatibility is also necessary for grease which should be used on all "O" rings to ensure proper assembly without damage.

THREAD LOCKING AND SEALANT

Several screws require a thread locking compound for locking in position. When thread locking compound is required use Loctite® #242 or equivalent. Where hydraulic sealant is specified, use Loctite® Hydraulic Sealant or equivalent. Where gasket sealant is specified, use Loctite® Master Gasket or equivalent.

ASSEMBLY

Refer to illustration, see figure 1. See page 26 for tightening torque on plugs

1. Place the port block end of the housing (7) on a suitable surface capable of supporting the pump weight of 177 lbs, 80,3 Kgs.
2. Install plugs (41) with "O" rings into port block. Install plugs (32) with "O" rings into port block.
3. Install pin (16) in port block. Position port plate (14) on port block and over pin. To view correct port plate for shaft rotation specified. **See illustration, below**

Port Plate for CW Shaft Rotation **Port Plate for CCW Shaft Rotation**
 (Ref. Barrel and Port Plate Assembly S22-16145) (Ref. Barrel and Port Plate Assembly S22-16146)

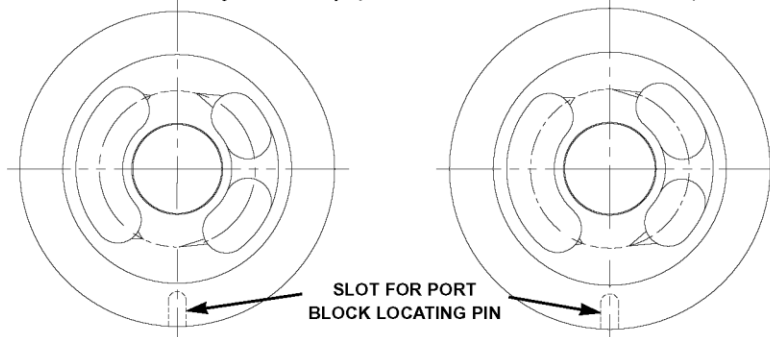

PUMP REASSEMBLY INSTRUCTIONS

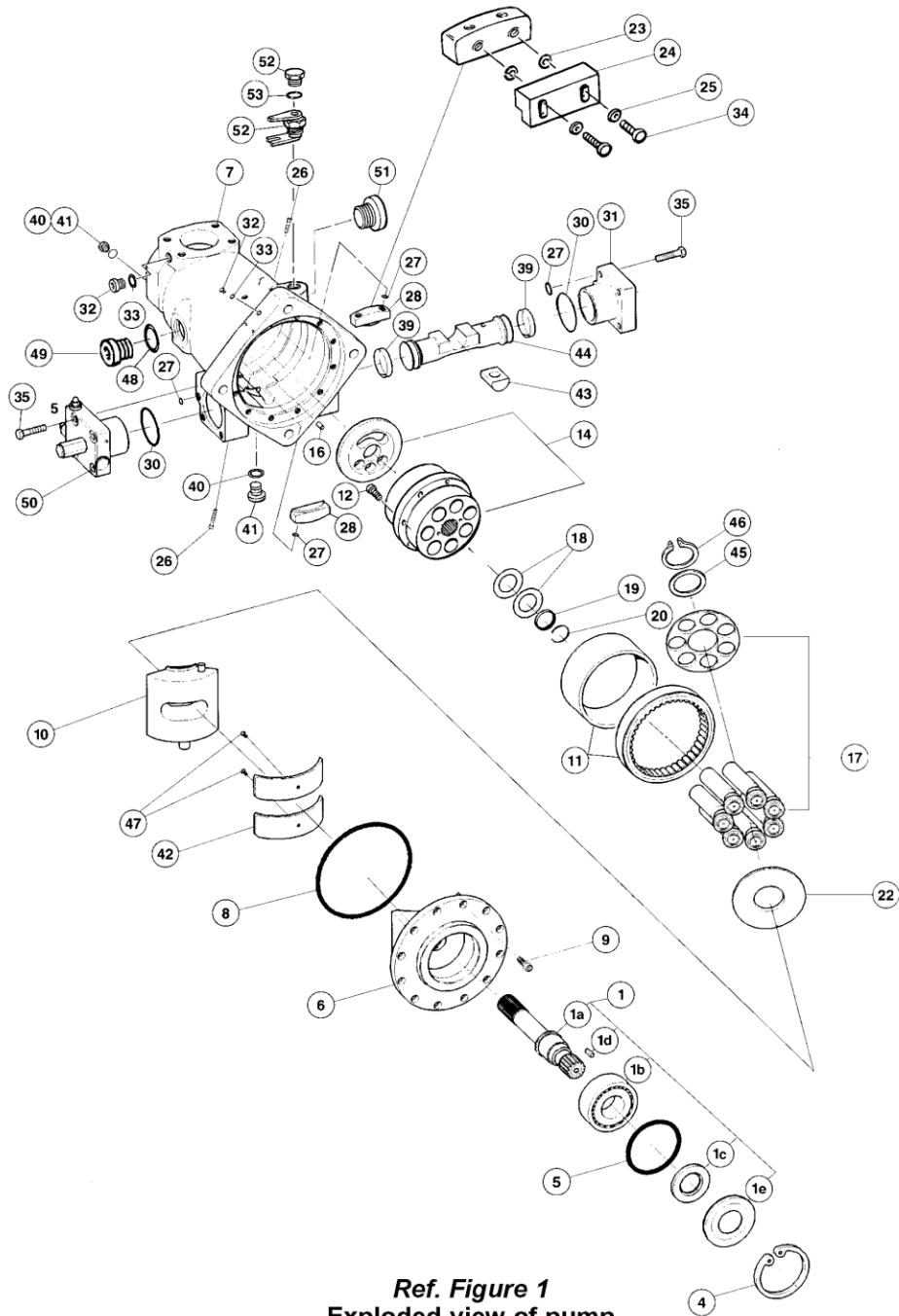

Ref. Figure 1
Exploded view of pump
with
pressure compensator control

PUMP REASSEMBLY INSTRUCTIONS

4. Press bearing outer race (11) into housing (7).

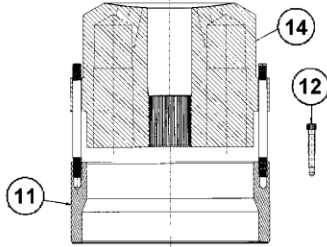

BARREL AND INNER RACE ASSEMBLY

5. Thread seven M8-1,25 studs into bearing inner race. Lower barrel (14) over studs and seat. If the inner race is heated to 150°F, 65°C, barrel will slide into position without force. If race is not heated, longer screws (12) can be used to draw the race and barrel together. Insert screws (12) and torque to 30 lbs-ft., 40 Nm. **See illustration**
6. Apply oil to face of port plate and inner bearing race. Attach tool T-1 to barrel with two M6 screws. Carefully lower barrel assembly into housing engaging inner race into rollers of outer bearing race, barrel may then be lowered until it has seated on port plate.
7. Insert two "O" rings (27) into each retainer (28). Apply thread locking compound to two screws (26) and secure retainer to housing. Torque to 84 lbs-in., 9,5 Nm.
8. Apply thread locking compound to two screws (26) and assemble the other retainer on opposite side of housing. Torque to 84 lbs-in., 9,5 Nm.
9. Assemble the two piston rings (39) on control piston (44). Insert control piston (44) into housing bore that is used with the control caps. **For CW shaft rotation**, the long end of the piston must be positioned to the right. (**Ref. fig.1**) **For CCW rotation**, the long end of the piston is to the left.
10. Position Belleville washers (18) on barrel, **See illustration**. To insure proper pump operation and correct barrel holddown force they must be assembled exactly as shown. Place barrel stop (19) on Belleville washers and center the washers and stop on barrel.

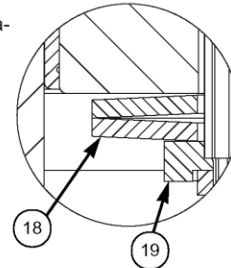

CAM ASSEMBLY

11. Set cam assembly (10) on suitable surface protecting cam surfaces from damage during assembly. **See illustration**
12. Place wear plate (22) on cam.
13. Position pistons-shoes-retainer assembly (17) over center post and against wear plate.
14. Install thrust washer (45) over center post.
15. Six different retainers (46) are available for setting the shoe holddown. Each retainer is marked: **white dot** .062", 1,57 mm thick, **red dot** .064", 1,63 mm thick, **green dot** .067", 1,70 mm thick, **yellow dot** .069", 1,75 mm thick, and **blue dot** .071", 1,80 mm thick. Install the thickest retainer **with the dot side up**, that will fit in the groove on the center post and allow a clearance of .003"-.005", 0,076-0,127 mm between the shoe and wear plate. **A .003", 0,076 mm feeler gage must go** completely under any shoe, and a **.005", 0,127 mm feeler gage must not go** under any shoe while holding a piston and lifting tightly against the shoe retainer. The piston and shoe assembly must be free to rotate easily by hand. Rotate 360° to confirm there is no binding and that each shoe is free in the retainer plate. Oil the assembly thoroughly.
16. Install slide link (43) on rocker cam pin as shown.
17. Oil barrel bores before installing cam assembly. The piston must be moved outward (*away from pump center*) so that clearance is provided for installing the rocker cam assembly. Lower cam assembly into the housing with the slide link positioned so it will engage into the control piston (44). The seven pistons (17) must first be engaged into the barrel bores. Next the slide link (43) must engage into the control piston (44). Continue lowering rocker cam assembly until it is seated on cam/bearing retainers (28).
18. Apply thread locking compound to two screws (34) and assemble clearance-bearing (24) to cam-bearing retainer (28) using the screws (34), two washers (25) and two washers (23). Move rocker cam to the right until it is against stop. **Set clearance** between clearance bearing (24) and cam at .006", 0,152 mm. Torque screws to 6 lbs-ft., 8,1 Nm maintaining the .006", 0,152 mm clearance.

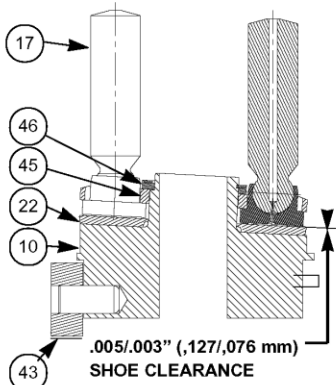

19. Adjust piston (44) toward the *off stroke* control side (31). This will place the cam at approximately zero displacement and provide clearance for the shaft installation.

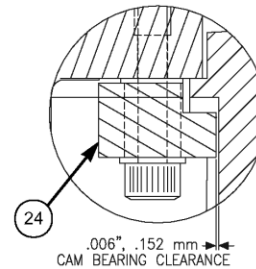

PUMP REASSEMBLY INSTRUCTIONS

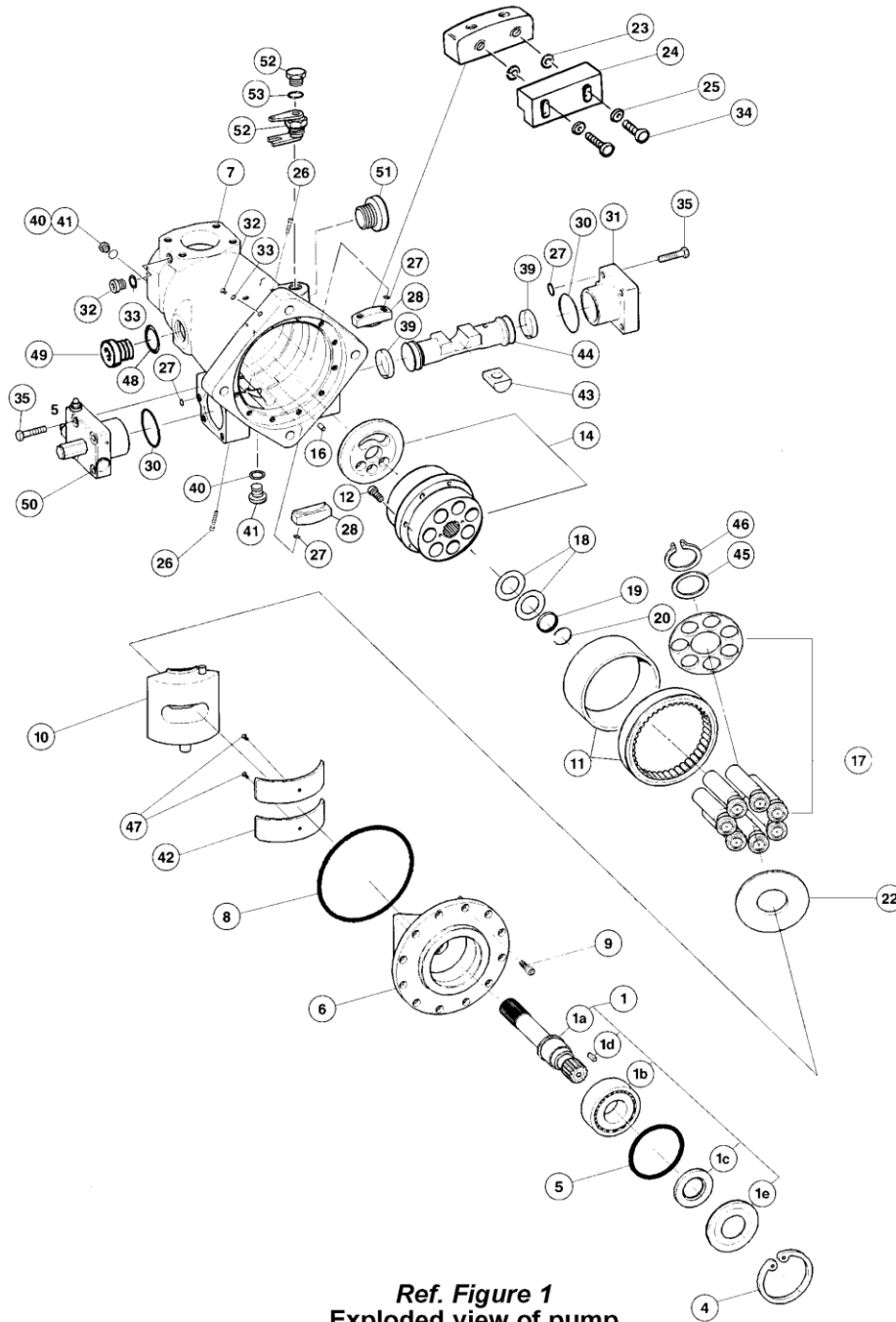

Ref. Figure 1
Exploded view of pump
with
pressure compensator control

PUMP REASSEMBLY INSTRUCTIONS

- Continued -

Rocker cradle assembly

20. Apply thread locking compound to two screws (47) and assemble two cam bearings (42) to cradle (6). Torque to 33 lbs-in., 3,8 Nm.

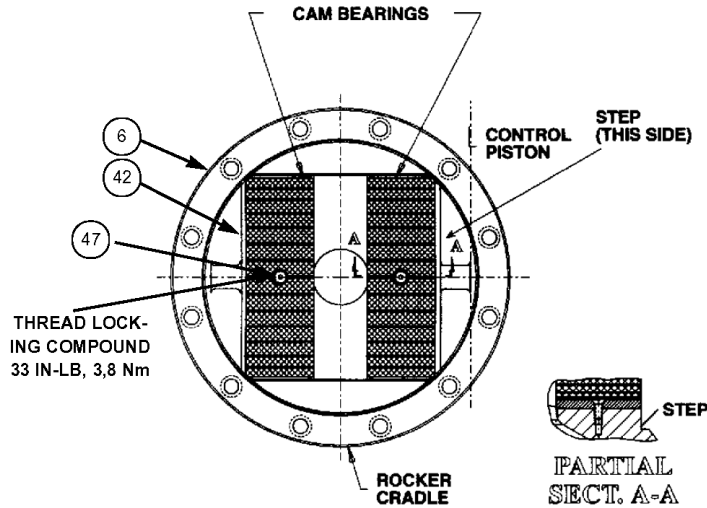

21. Press bearing (1b) on shaft (1a). Press on inner race only.
22. Apply over 360° bead of gasket sealant to seal retainer (1e) per following sketch. Press shaft seal (1c) into seal retainer (1e).
23. Install shaft seal and retainer on shaft using Tool T-3 to protect seal.
24. Install "O" ring (5) in cradle (6).
25. Press seal retainer and bearing and shaft assembly into bore of cradle (6) using Tool T-2.
26. Install snap ring (4) to cradle.
27. Install "O" ring (8) to rocker cradle.

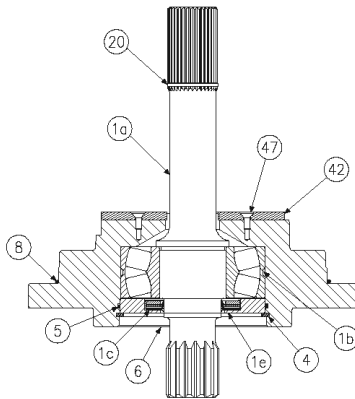
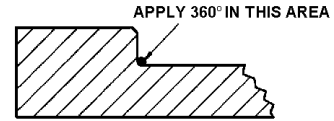

28. Install retaining ring (20) on shaft.
29. Center Belleville washers and barrel stop. Lower rocker cradle assembly into pump housing with the step in the rocker cradle correctly positioned so that clearance is provided for slide link (43). The threaded hole in the end of shaft should be used to support the assembly. SAE shafts use 3/8-16 threads, ISO shafts use M10 threads, DIN shafts use M12 threads. The shaft spline must first engage the splined barrel stop (19), thru the Belleville washers (18) and engage the barrel spline. The assembly will then rest on the cam.
30. Install socket head cap screws (9) as shown. Torque evenly to 57 ft-lb (77 Nm). Install case drain plug (49) and shipping plug (51). If pump does not contain displacement indicator, install plug (52) and "O" ring (53) in indicator hole.

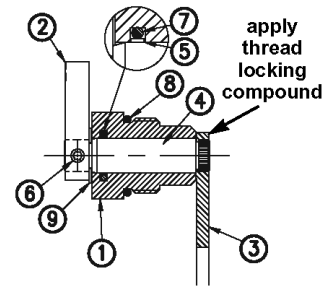

ref. Figure 2
Indicator assembly

INDICATOR ASSEMBLY OPTION

See figure 2. To install indicator assembly, loosen setscrew (6), remove indicator (2) and slide shaft out of nut (1). Guide fork into indicator hole in housing to engage the pin on the hanger. a 1/4-20 SHCS or threaded rod may be used to hold the shaft. Slide nut (1) over shaft and tighten nut in threaded hole. Pull shaft out to slip retaining ring (9) into groove in shaft. Use maximum volume stop to set pump on zero displacement (10.2 turns from full). Install indicator, set pointer on "0" and lock in position.

PUMP REASSEMBLY INSTRUCTIONS

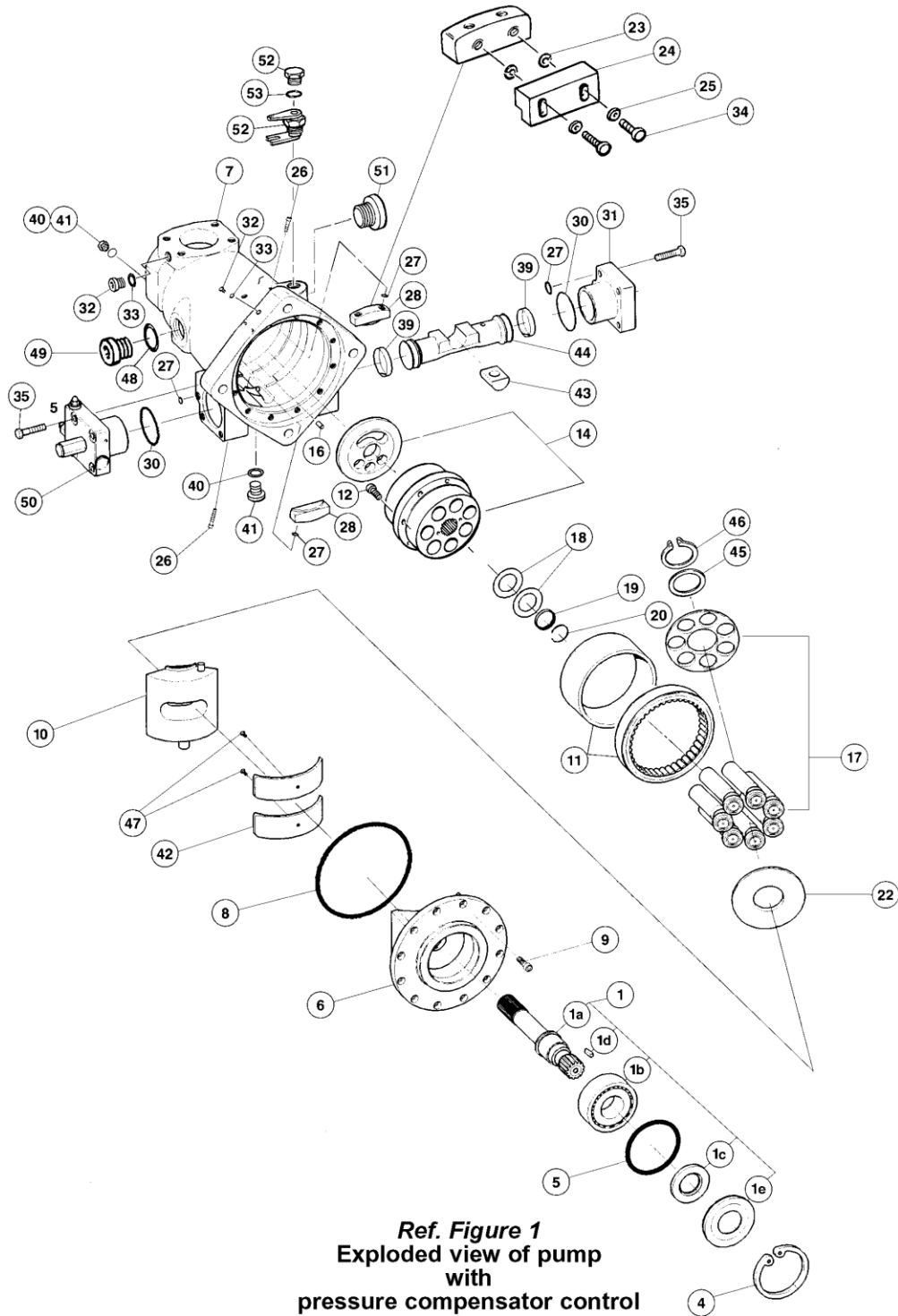

PUMP REASSEMBLY INSTRUCTIONS

CONTROLS ASSEMBLY

Install control cap assemblies (50) and (31). The control caps must be positioned on the housing for either CW or CCW pump rotation. See figures 4 & 5 for correct orientation. The control piston (44) was assembled previously for the correct pump rotation. Install eight hex head cap screws (35) into caps and torque to housing with 75 lbs-ft., 102 Nm.

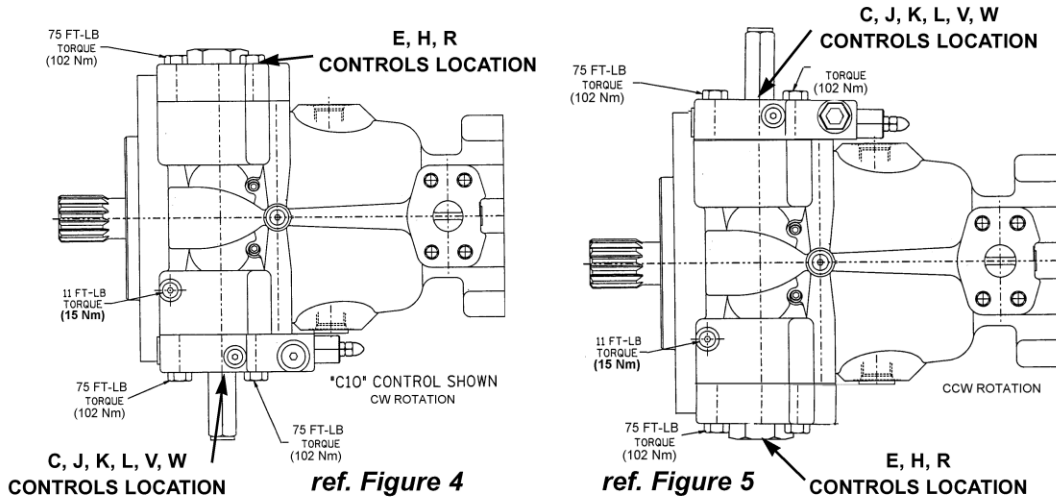

If the pump has a rear drive feature, assemble coupling and adapter. See illustration, figure 3.

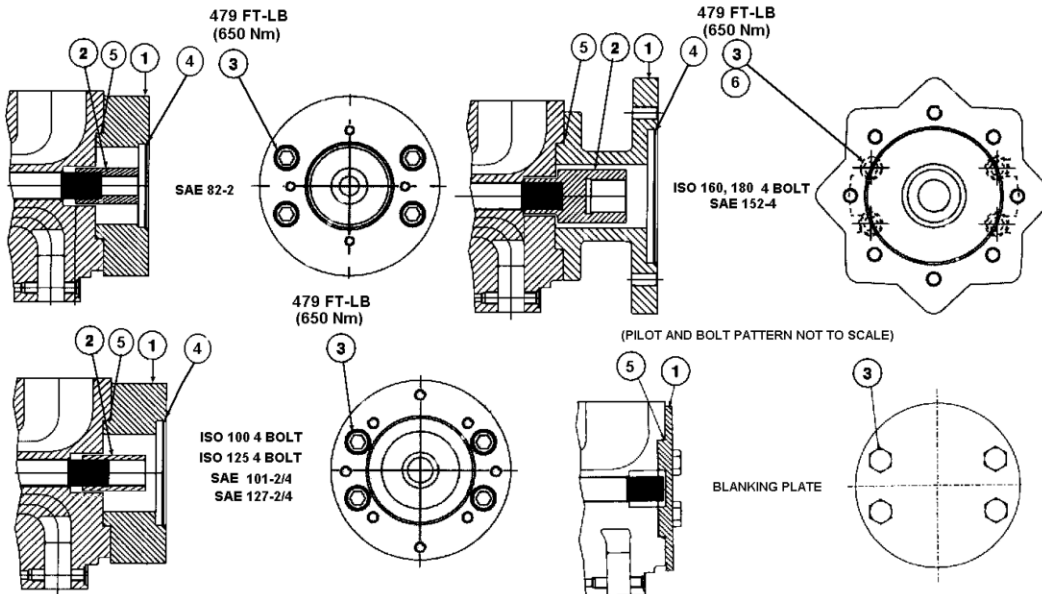

Ref. Figure 3

CONTROLS

GENERAL

The instructions contained in this manual cover complete disassembly and reassembly of the controls. Before proceeding with the disassembly or reassembly of any unit, this manual should be studied in order to become familiar with proper order and parts nomenclature.

DESCRIPTION OF OPERATION

A pilot operated valve spool and sleeve combination is the core of the control function. For the compensator, torque limiter and load sensing controls, system pressure is applied to the input port of a three-way valve, and to one end of the valve spool. A small orifice feeds this pressure to the other end of the spool, and limits pilot flow to approximately 115 in³/minute, 1,9 lpm. A spring on this end biases the spool to normally port the control piston to pump case. This control piston links to the pump cam. On the opposite end of the control piston a small back-up piston connects to system pressure. This force, pump timing forces, and a spring combine to put the pump on stroke.

PRESSURE COMPENSATOR

A spring-loaded cone and seat connected to the spring end of the three-way spool establishes an adjustable pressure limit on this end of the spool. When system pressure reaches this value, flow through the spool creates a pressure difference across the spool. At approximately 250 psi, 17,2 bar difference, the spool shifts toward the spring, re-directing the control piston port to system pressure. This pressure applied to the control piston overcomes the forces putting the pump on stroke, causing the pump to reduce displacement. When the pump pressure drops, the spool meters to maintain the pump pressure at approximately 250 psi, 17,2 bar above the controlled pressure on the spring side. The spring end of this three-way spool may also be connected to a remote pressure control, through the vent port, "V".

LOAD SENSING CONTROL

In the load sensing control, the system load pressure is applied to a modulating valve which establishes the compensator vent pressure at 200 psi, 13,8 bar above load pressure. Adding the differential pressure across the compensator spool to this pressure, the pump outlet pressure is approximately 350 psi to 450 psi, 24,1 to 31 bar above load pressure. There is essentially no flow in the sensing line, and the pump supplies the flow required to develop 350 psi to 435 psi, 24,1 to 30 bar across the metering valve to the load.

TORQUE LIMITER

The input torque is limited to a set value with the torque limiter control. To limit input torque, pump displacement is reduced when pressure increases, and vice versa. This is accomplished by controlling the compensator pilot pressure with a linkage to the pump stroking piston.

The compensator vent connects to one end of a pin which is spring loaded on the other end. The pin slides through a spool which is positioned by a linkage to the control piston. Vent flow passes through the pin to a cross drilled hole, which is opened or blocked by the motion of the spool. As system pressure increases, the pin moves against the springs till the cross drilled passage opens, venting the compensator and causing the pump to reduce displacement. As displacement reduces, the sleeve follows, closing the cross drilled passage and establishing control at a higher pressure. For any pressure, there is a corresponding pump displacement. The position of the spool is controlled by the pressure acting against two springs, one which is always in contact with the pin, and the other which comes in contact as pressure increases, providing an increase in spring rate as pressure increases.

TORQUE LIMITER WITH LOAD SENSING

A modulating valve is mounted to a torque limiter body to provide a load sensing control with torque limiting and pressure compensator override.

ROTARY SERVO CONTROL

The rotary servo control is mounted on the off-stroke side of the control piston. Servo pressure is connected to the input port of a four-way valve, and to the end of this valve spool. A drilling and orifice connects to the opposite end of the spool. One cylinder port connects to the "off stroke" end of the control piston, while the other cylinder port connects to the "on stroke" end of the control piston, through the control on the opposite side.

A rotatable shaft converts to a linear motion on a pin. A sleeve over the pin is driven by a linkage to the control piston. The sleeve/pin combination meters pilot flow from the four-way valve controlling the shifting of the four-way valve, in such a manner that the four-way valve shifts to hold the cylinder position to the corresponding position for the input rotation.

CONTROLS

HYDRAULIC STROKER

In the hydraulic stroker, a spring loaded piston is attached to the pin. A control pressure of 50 psi, 3,45 bar causes the piston to commence to move against the spring, to position the pin in proportion to the control pressure, and thus cause the pump to stroke in proportion to control pressure. Full displacement is achieved at 225 psi, 15,5 bar.

ELECTRIC STROKER

By mounting an electrically modulated pressure control valve on the hydraulic stroker to establish the control pressure, pump displacement is controlled by an electrical signal. For a 24 volt coil, the pump commences to stroke at approximately 175 mA electrical signal, and will be at full displacement at approximately 275 mA.

PRESSURE COMPENSATOR AND TORQUE LIMITER OVERRIDE

An override pressure compensator or a torque limiter control mounts on the smaller diameter of the control piston, opposite the servo, hydraulic or electric stroker. In the normal position, the spool in the override control connects this piston to the control valve on the opposite side, allowing control by the stroker. When system pressure or torque exceed the override setting, this spool connects system pressure to the smaller diameter control piston, to override the rotary servo, hydraulic or electric stroker command and reduce displacement according to the compensator or torque limiter setting. Override pressure must be sufficient to overcome servo pressure acting on the larger diameter piston.

TIGHTENING TORQUE FOR HYDRAULIC PLUGS

PORT SIZE	ft-lbs	Nm
SAE-4	11	15
SAE-6	18	24
SAE-8	46	62
SAE-10	75	102
SAE-14	130	175
SAE-16	135	183
1/4 BSPP	18	24
3/8 BSPP	18	24
1/2 BSPP	93	126
1" BSPP	146	198

PORT SIZES

.....DESCRIPTION	P07 C MOD	P110 C MOD
PORT C1OFF-STROKE CYLINDER GAGE.....	SAE-4	1/4 BSPP
PORT C2ON-STROKE CYLINDER GAGE.....	SAE-4	1/4 BSPP
PORT DCASE DRAIN	SAE-20	1-1/4 BSPP
PORT D1CASE DRAIN	SAE-20	1-1/4 BSPP
PORT DG.....DRAIN GAGE, AIR BLEED PORT	SAE-4	3/8 BSPP
PORT AG.....INLET GAGE	SAE-4	1/4 BSPP
PORT BG.....SYSTEM GAGE.....	SAE-4	1/4 BSPP
PORT BG1....ALTERNATE SYSTEM GAGE.....	SAE-6	1/4 BSPP
PORT EELECTROHYDRAULIC STROKER SERVO SUPPLY	SAE-4	1/4 BSPP
PORT HHYDRAULIC STROKER SIGNAL.....	SAE-4	1/4 BSPP
PORT LSLOAD SENSING LINE.....	SAE-4	1/4 BSPP
PORT VCOMPENSATOR, TORQUE LIMITER, LOAD SENSING VENT	SAE-8	3/8 BSPP
PORT V1SERVO VENT	SAE-4	1/4 BSPP
PORT XSERVO SUPPLY	SAE-6	3/8 BSPP
PORT XG.....SERVO GAGE	SAE-10	1/2 BSPP

PRESSURE COMPENSATOR CONTROL

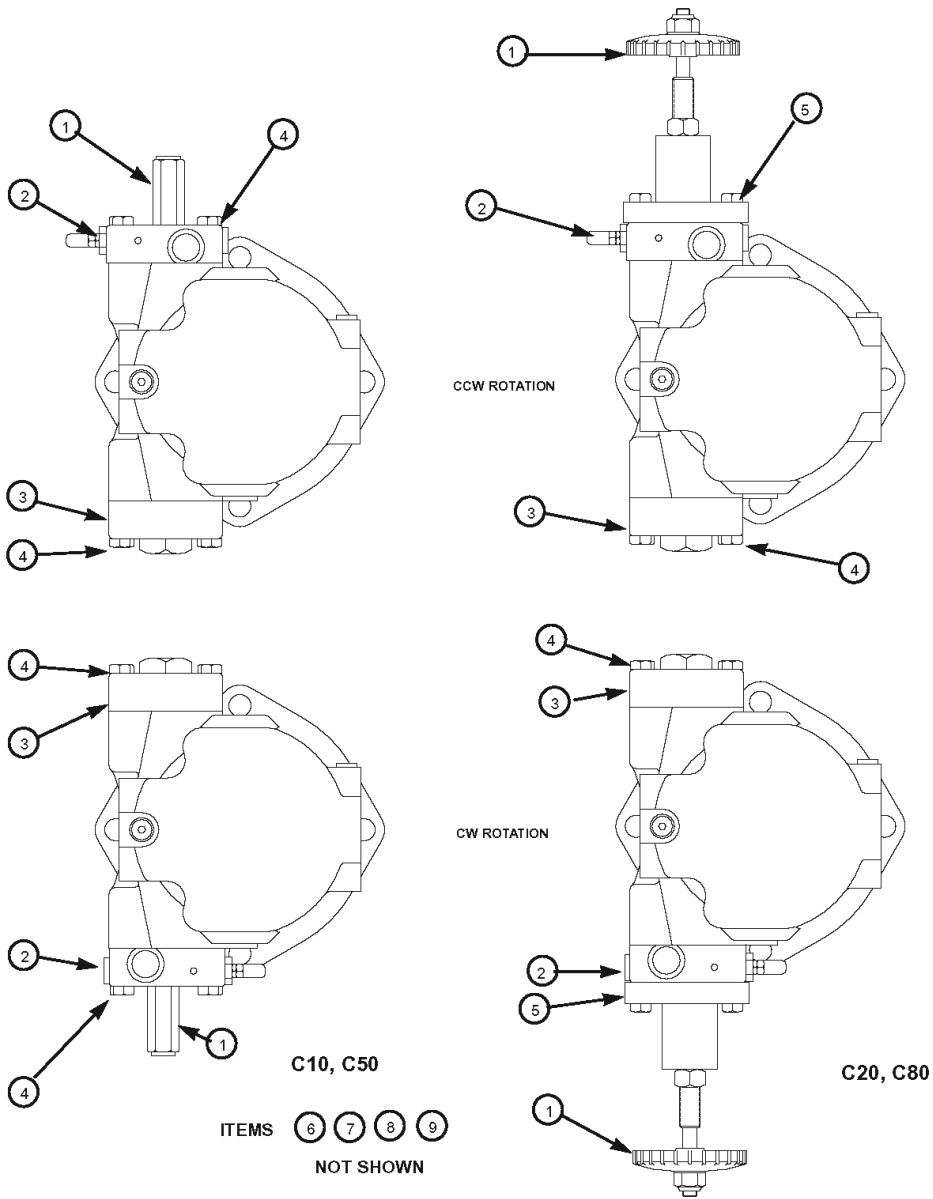

PRESSURE COMPENSATOR
parts list

ITEM	DESCRIPTION	P07	P110	QTY.	
		PART NO.	PART NO.	C10/50	C20/80
1	Maximum Stop (Fig. 7)	S22-15467	S22-15467	1	—
	Maximum Handwheel (Fig. 8)	S22-15448	S22-15448	—	1
2	*Compensator Control (Fig. 6)	S22-15394	S22-15623	1	—
	*Compensator Control (Fig. 6)	S22-15626	S22-15633	—	1
3	Buck Up Cap (Fig. 9)	S22-15447	S22-15447	1	1
4	Screw-H.H.C., M12 x 55 mm	363-12205	363-12205	8	6
5	Screw-H.H.C., M12 x 75 mm	363-12220	363-12220	—	2
6	Control Piston	032-91836	032-91836	1	1
7	O-Ring, 90 S-1 ARP 013	691-00013	691-00013	2	2
8	O-Ring, 70 S-1 ARP 151	671-00151	671-00151	2	2
9	Piston Ring	032-91816	032-91816	2	2

*Include items 1, 4, 5, 7 and 8

COMPENSATOR DISASSEMBLY

1. **See Figure 6.** Back off maximum volume screw or handwheel to full displacement. Remove maximum volume screw or handwheel assembly.
2. Remove bolts holding cap to pump.
3. Remove plug (15) and attached parts. Remove spring (11) and spool (18).
4. Remove adjusting plug (2) and attached parts. Remove seal piston (5). Note: a 10-24 screw may be used to assist in pulling the piston. Remove spring (7) and cone (8).
5. Do not remove sleeve in body (1). Sleeve is pressed into cap and finished to size. If sleeve or cap is worn, replace the cap-sleeve assembly (1).
6. Examine seat (10) for wear. Do not remove unless damaged.

ASSEMBLY

See page 26 for tightening torque on plugs

1. Install Avseal plugs (9) and .047", 1,19 mm. orifice (19) in body.
2. Press seat (10) into bore squarely against shoulder in bore.
3. Install spool (18) into bore as shown. Install spring (11) over end of spool. Install O-ring (6) on seal piston (16). Lubricate and install into plug (15). Install plug (15) into cap. Install screw (3), nut (4) and plastic cap (17).
4. Install O-ring (6) on seal piston (5).
5. Lubricate O-ring and install cone (8), spring (7) and seal piston into bore in cap (1), being careful that cone enters seat (10). Install remaining parts. Torque plugs (12) and (21)
6. Note proper location for cap on pump (pg. 24). Install O-rings on interface between cap and pump control pad.
7. Install cap on pump control pad, guiding the control piston into the bore. Install maximum volume stop assembly.
8. Torque mounting bolts to 75 lbs.* ft., 102 N m.

PRESSURE COMPENSATOR CONTROL

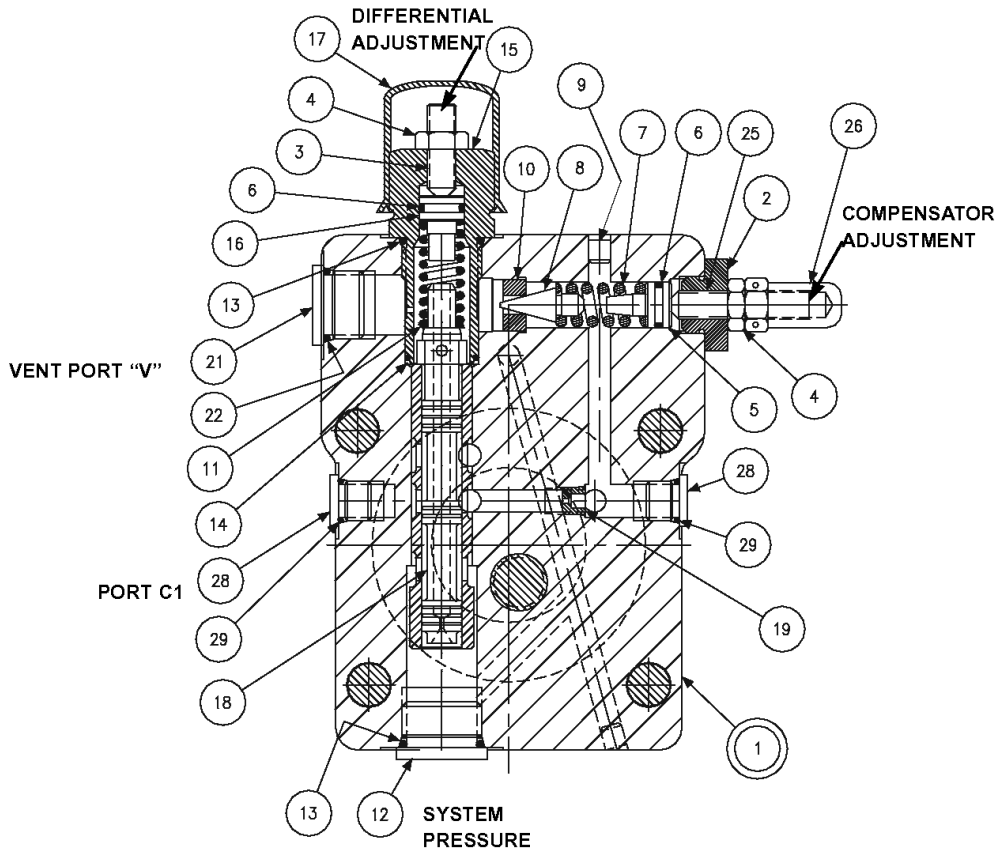

FIGURE 6

PARTS LIST FOR FIGURE 6

P07 C10 compensator S22-15394
P110 C10 compensator S22-15623
P07 C20 compensator S22-15626
P110 C20 compensator S22-15633

ITEM	DESCRIPTION	P07		P110	
		PART NO.	QTY.	PART NO.	QTY.
1	Cap-Sleeve Assembly	S22-15321	1	S22-15604	1
2	Adjusting Plug	032-91814	1	032-91814	1
3	Socket Setscrew 5/16-24 x 1	312-13160	1	312-13160	1
4	Nut, 5/16-24	335-13100	2	335-13100	2
5	Seal Piston	031-59367	1	031-59367	1
6	O-Ring, 90 S-1 ARP 012	691-00012	2	691-00012	2
7	Spring	032-91798	1	032-91798	1
8	Cone	036-12288	1	036-12288	1
9	Avseal Plug	447-00026	2	447-00026	2
10	Seat	036-11692	1	036-11692	1
11	Spring	033-71086	1	033-71086	1
12	Plug	488-35055	1	447-01008	1
13	O-Ring, 90 S-1 ARP 910	691-00910	2	691-00910	1
14	O-Ring, 90 S-1 ARP 017	691-00017	1	691-00017	1
15	Plug	031-57368	1	031-57368	1
16	Seal Piston	032-91305	1	032-91305	1
17	Cap	449-00612	1	449-00612	1
18	Spool	032-59482	1	032-59482	1
19	Orifice Plug, .047", 1.19 mm.	033-25528	1	033-25528	1
21	Plug	488-35018	1	447-00032	1
22	O-Ring, 90 S-1 ARP 908	691-00908	1	-	-
25	Setscrew 5/16-24 x 1-1/4	312-13180	1	312-13180	1
26	Acorn Nut	036-33474	1	036-33474	1
28	Plug	488-35061	2	447-01004	2
29	O-ring, 90 S-1 ARP 904	691-00904	2	-	-

MAXIMUM VOLUME STOP

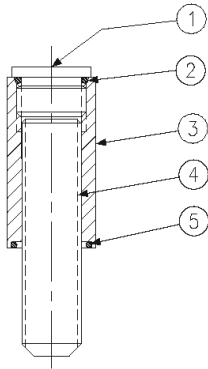

Figure 7
maximum volume stop

PARTS LIST FOR FIGURE 7
maximum volume stop S22-15467

ITEM	DESCRIPTION	PART NO.	QTY.
1	Plug 8HP5N-S	488-35018	1
2	O-Ring, 90 S-1 ARP 908	691-00908	1
3	Nut, M16 Hex	032-91822	1
4	Screw, Soc. Set	311-50001	1
5	O-Ring, 70 S-1 ARP 115	671-00115	1

1

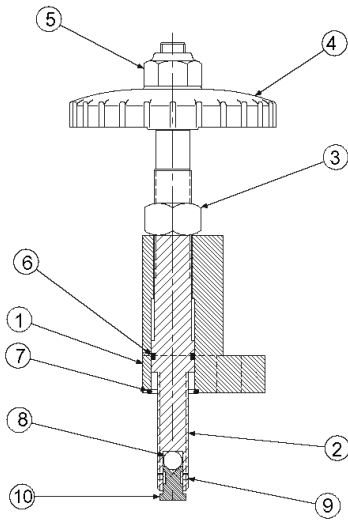

Figure 8
Handwheel maximum volume stop

PARTS LIST FOR FIGURE 8
handwheel S22-15448

ITEM	DESCRIPTION	PART NO.	QTY.
1	Bracket	032-92056	1
2	Screw	032-92057	1
3	Nut, Hex	333-25000	1
4	Handwheel	031-59911	1
5	Nut, Elastic Stop 1/2-13	331-20100	1
6	O-Ring, 90 S-1 ARP 115	691-00115	1
7	O-Ring, 90 S-1 ARP-118	691-00118	1
8	Ball	201-12001	1
9	Ball	201-04001	2
10	Seat	032-92058	1

MAXIMUM VOLUME HANDWHEEL DISASSEMBLY

1. See Fig. 8. Remove the two screws holding the bracket (1) to the control cap.
2. Turn the handwheel counter-clockwise to remove the stop screw from the control cap.
3. Remove nut (5) and handwheel (4) from the stop screw (2).
4. Remove nut (3). Screw (2) may now be slipped through the bracket (1) to examine parts and to replace O-ring (6).
5. Seat (10) pivots and rotates on ball (8) and is retained by pressing two balls (9) into screw (2). Replace assembly if damaged.

ASSEMBLY

1. Install ball (8) and seat (10) in screw (2).
2. Press balls (9) into screw (2) to retain seat
3. Install O-ring (6) on screw (2). Lubricate O-ring and slide screw into bracket (1). Install remaining parts.
4. Turn handwheel clockwise into cap till the screw contacts the control piston.
5. Install and torque the assembly screws to 75 ft-lb, 102 Nm.

BUCK-UP CAP

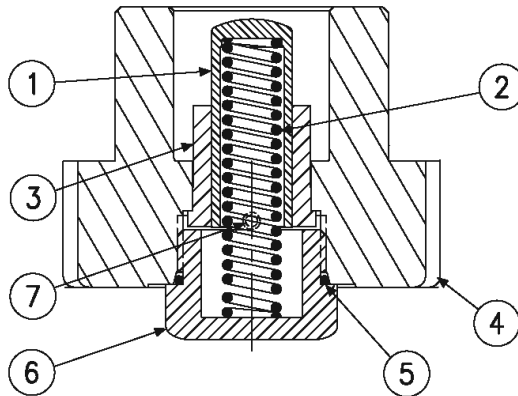

FIGURE 9
Buck-up cap assembly

PARTS LIST FOR FIGURE 9
buck-up cap S22-15447

ITEM	DESCRIPTION	PART NO.	QTY.
1	Piston	032-92202	1
2	Spring	032-92205	1
3	Sleeve	032-92203	1
4	Control Cap	032-91832	1
5	O-Ring	691-00920	1
6	Plug	032-92204	1
7	Avseal Plug	447-00026	1

BUCK-UP CAP DISASSEMBLY

1. **See Figure 9.** Set maximum volume stop to full displacement. Remove 4 screws holding cap to pump. Caution! Spring load could cause injury!
2. Remove cap assembly from pump.
3. Remove and examine spring (2) and piston (1). If sleeve (3) is worn, press it out and replace.

ASSEMBLY

1. Install Avseal plug (7) into cap. Press sleeve (3) into cap to shoulder. Install piston (1), O-ring (5) and plug (6) into cap.
2. Install O-rings on interface between cap and pump control pad. Install spring (2) into control piston. Install cap assembly on pump housing as indicated on page 17 Fig. 5, guiding the control piston into the bore.
3. Torque the assembly bolts to 75 ft-lb, 102 Nm. Torque plug (7) to 225 lb-ft, 305 Nm.

TORQUE LIMITER CONTROL

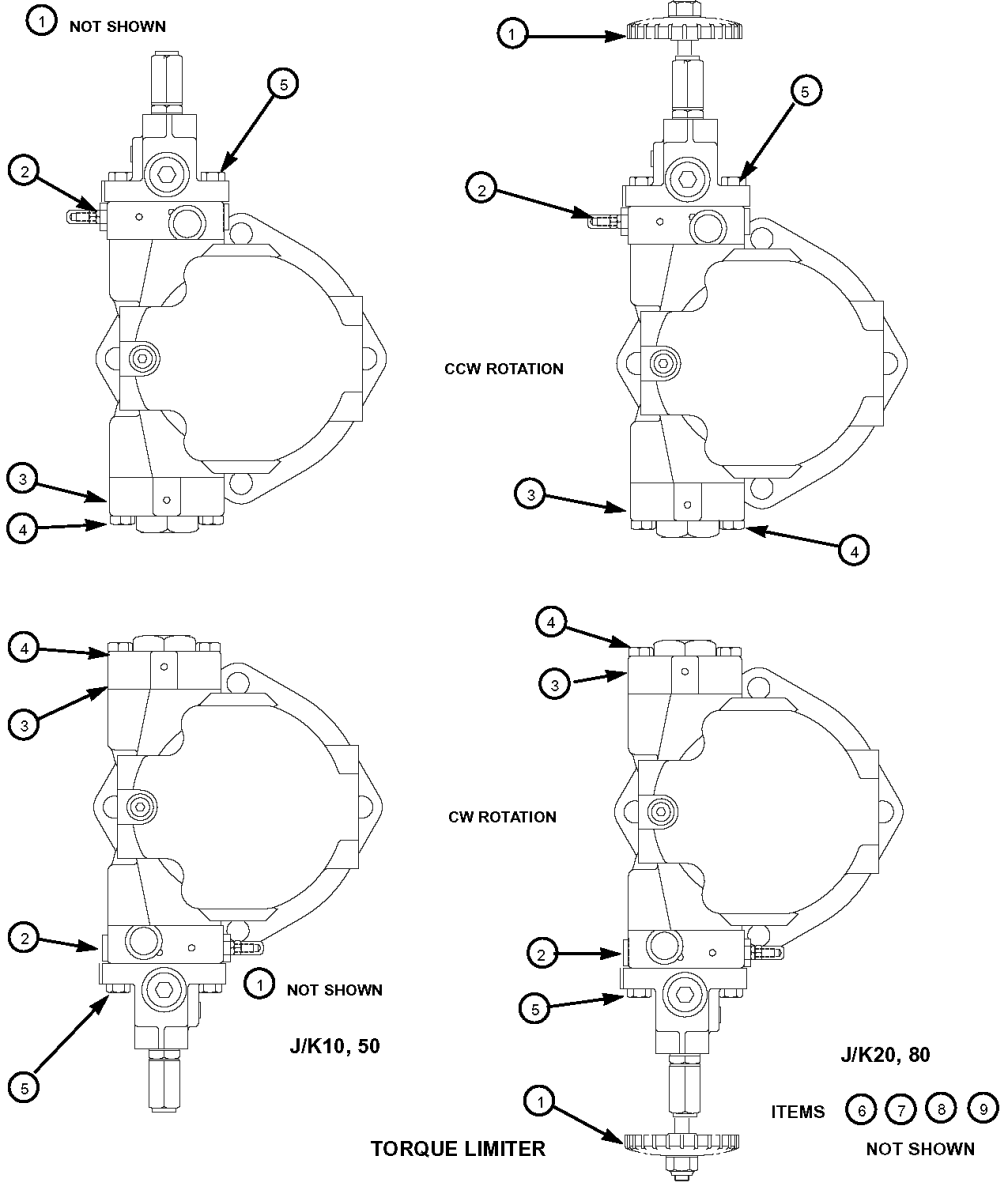

PARTS LIST
torque limiter

ITEM	DESCRIPTION	P07 PART NO	P110 PART NO.	QUANTITY			
				J10	K10	J20	K20
1	Maximum Stop (Fig. 7)	S22-15467	S22-15467	1	1	—	—
	Maximum. Handwheel (Fig. 8)	S22-15448	S22-15448	—	—	1	1
2	*Low Torque Limiter (J10)(Fig. 11)	S22-15401	S22-15624	1	—	—	—
	*Low Torque Limiter (J20)(Fig. 11)	S22-15627	S22-15634	—	—	1	—
	*High Torque Limiter(K10)(Fig. 11)	S22-15629	S22-15631	—	1	—	—
	*High Torque Limiter (K20)(Fig. 11)	S22-15635	S22-15636	—	—	—	1
3	Buck Up Cap (Fig. 9)	S22-15447	S22-15447	1	1	1	1
4	Screw-H.H.C., M12 x 55 mm	363-12205	363-12205	6	6	4	4
5	Screw-H.H.C., M12 x 80 mm	363-12220	363-12220	2	2	4	4
6	Control Piston	032-91836	032-91836	1	1	1	1
7	O-Ring, 90 S-1 ARP 013	691-00013	691-00013	2	2	2	2
8	O-Ring, 70 S-1 ARP 151	671-00151	671-00151	2	2	2	2
9	Piston ring	032-91816	032-91816	2	2	2	2

*Include items 1, 4, 5, 7 and 8

TORQUE LIMITER CONTROL

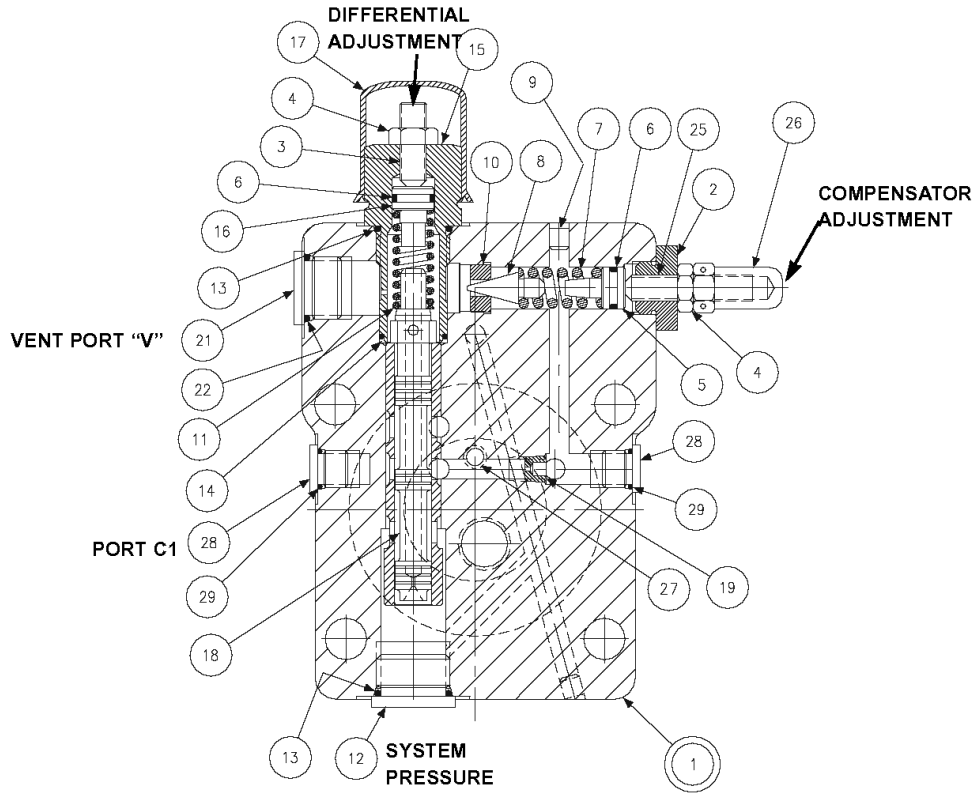

FIGURE 10
TORQUE LIMITER CAP

PARTS LIST FOR FIGURE 10
P 07 torque limiter cap S22-15407
P 110 torque limiter cap S22-15607

ITEM	DESCRIPTION	P07		P110	
		PART NO.	QTY	PART NO.	QTY
1	Cap-Sleeve Assembly	S22-15408	1	S22-15608	1
2	Adjusting Plug	032-91814	1	032-91814	1
3	Socket Setscrew 5/16-24 x 1	312-13160	1	312-13160	1
4	Nut, 5/16-24	335-13100	2	335-13100	2
5	Seal Piston	031-59367	1	031-59367	1
6	O-Ring, 90 S-1 ARP 012	691-00012	2	691-00012	2
7	Spring	032-91798	1	032-91798	1
8	Cone	036-12288	1	036-12288	1
9	Avseal Plug	447-00026	2	447-00026	2
10	Seat	036-11692	1	036-11692	1
11	Spring	033-71086	1	033-71086	1
12	Plug	488-35055	1	447-01008	1
13	O-Ring, 90 S-1 ARP 910	691-00910	2	691-00910	1
14	O-Ring, 90 S-1 ARP 017	691-00017	1	691-00017	1
15	Plug	031-57368	1	031-57368	1
16	Seal Piston	032-91305	1	032-91305	1
17	Cap	449-00612	1	449-00612	1
18	Spool	032-59482	1	032-59482	1
19	Orifice, .047", 1.19 mm.	033-25528	1	033-25528	1
21	Plug	488-35018	1	447-00032	1
22	O-ring, 70 S-1 ARP 908	691-00908	1	-	-
25	Setscrew 5/16-24 x 1-1/4	312-13180	1	312-13180	1
26	Nut, Acorn 5/16-24	036-33474	1	036-33474	1
27	O-Ring, 70 S-1 ARP 008	671-00008	1	671-00008	1
28	Plug	488-35061	2	447-01004	2
29	O-ring 90 S-1 ARP 904	691-00904	2	-	-

TORQUE LIMITER CONTROL

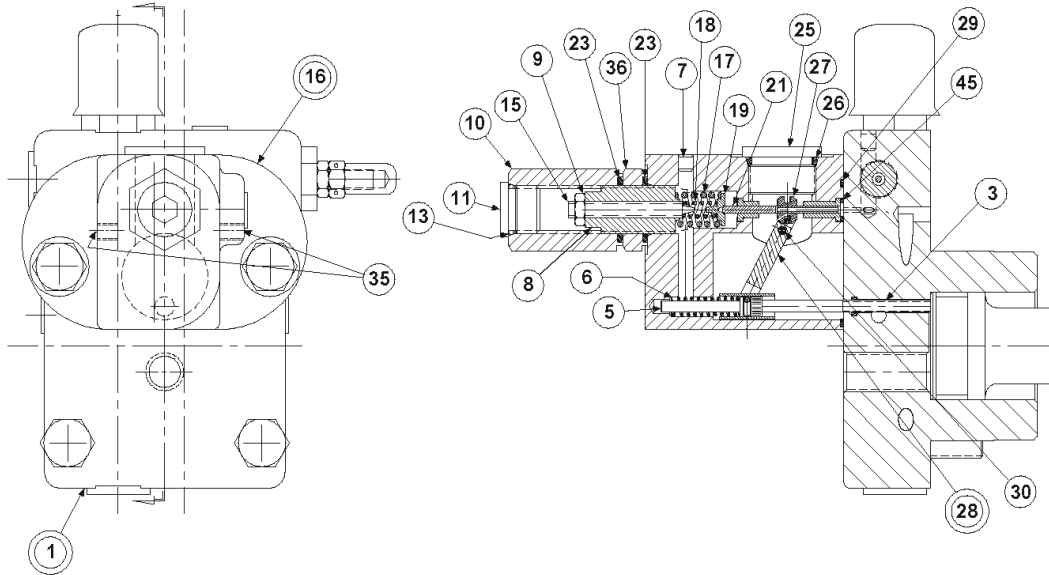

FIGURE 11
Torque Limiter

PARTS LIST FOR FIGURE 11

P07 code J10,J50 S22-15401
 P07 code J20,J80 S22-15627
 P07 code K10K50, S22-15629
 P07 code K20K80, S22-15635
 P110 code J10J50, S22-15624
 P110 code J20,J80 S22-15634
 P110 code K10K50, S22-15631
 P110 code K20,K80 S22-15636

ITEM	DESCRIPTION	P07	P110	QTY.	
		PART NO.	PART NO.	J	K
1	Cap (Figure 10)	S22-15407	S22-15607	1	1
3	Screw	032-91461	032-91461	1	1
5	Clevis pin	321-40000	321-40000	1	1
6	Spring, Compression	032-92100	032-92100	1	1
7	Plug, Avseal	447-00026	447-00026	1	1
8	Screw	032-91445	032-91445	1	1
9	Nut, Hex Jam 1/4-20 UNC	340-00038	340-00038	1	1
10	Hex Nut, 3/4-16 UNF	032-91449	032-91449	1	1
11	Plug, 8HP N-S	488-35018	488-35018	1	1
14	O-Ring, 90 S-1 ARP 908	691-00908	691-00908	1	1
15	Screw, Primary Adjusting	032-91446	032-91446	1	1
16	Body assembly	S22-15396	S22-15396	1	1
17	Outer Spring – J Version	032-91440	032-91440	1	—
	Outer Spring – K Version	032-91440	032-91440	—	1
18	Inner Spring – J Version	032-92240	032-92240	1	—
	Inner Spring – K Version	032-91441	032-91441	—	1
19	Spring Retainer	032-91819	032-91819	1	1
21	Spool	032-91438	032-91438	1	1
23	O-ring, 70 S-1 ARP 118	671-00118	671-00118	2	2
25	Plug, 12 HP5N-S	488-35014	488-35014	1	1
26	O-Ring, 90 S-1 ARP 912	691-00912	691-00912	1	1
27	Sleeve	032-91437	032-91437	1	1
28	Arm assembly	S22-15520	S22-15520	1	1
29	O-Ring, 70 S-1 ARP 035	671-00035	671-00035	1	1
30	Dowel Pin, 1/8 Dia. x 1.50 Lg.	324-20824	324-20824	1	1
35	Screw, SHC 10-32 x 1/4	312-09041	312-09041	2	2
36	Nut	032-91645	032-91645	1	1
45	O-Ring, 70 S-1 ARP 010	671-00010	671-00010	1	1

TORQUE LIMITER CONTROL

DISASSEMBLY

1. See Figure 11. Remove 2 screws holding torque limiter body (16) to cap assembly (1).
2. Remove all parts from torque limiter body (16) except pin (30) and arm assembly (28). It is not necessary to remove these parts unless broken or worn. Examine parts for wear or damage.
3. Remove screw (3). Examine head for excessive wear, and body for smooth sealing surface with O-ring.
4. Remove maximum stop handwheel assembly or maximum stop screw assembly.
5. Remove cap assembly (1).
6. See Figure 10. Remove plug (15) and attached parts. Remove spring (11) and spool (18).
7. Remove adjusting plug (2) and attached parts. Remove spring (7) and cone (8).
8. Do not remove sleeve in body (1). Sleeve is pressed into cap and finished to size. If sleeve or cap is worn, replace the cap-sleeve assembly (1).
9. Examine seat (10) for wear. Do not remove unless damaged.

ASSEMBLY

See page 26 for tightening torque on plugs

1. See Figure 10. Install Avseal plugs (9) and .047", 1,19 mm. orifice (19) in body.
2. Press seat (10) into bore squarely against shoulder in bore.
3. Install spool (18) into bore as shown. Install spring (11) over end of spool. Install O-ring (6) on seal piston (16). Lubricate and install into plug (15). Install plug (15) into cap. Install screw (3), nut (4) and acorn nut (17). Install plug (12), (21) and (28). Torque plugs.
4. Install O-ring (6) on seal piston (5). Lubricate O-ring and install cone (8), spring (7) and seal piston (5) into bore in cap (1), being careful that cone enters seat (10). Install adjusting plug (2), screw (25), nut (4) and acorn nut (26).
5. Carefully install O-ring (27) in the cap.
6. Note proper location for control cap (pg. 24). Install O-rings on interface between cap and pump control pad. Install cap, guiding control piston into bore. Torque mounting screws to 75 lb.*ft., 102 Nm.
7. Install maximum volume handwheel or screw assembly. Set stop to clear control piston.
8. See Figure 11. Apply thread locking compound on threads of screw (3), lubricate the shank, thread through the cap into the control piston, and torque to 5 lb.*ft., 6,8 Nm
9. Measure height from control cap to top of screw. With control piston at full displacement, dimension must be 1.50 +/- .03 in., 38,1 +/- 0,76 mm.
10. Press dowel (30) into body (16), through the link assembly (28), to 1/4", 6,35 mm below surface. Apply hydraulic sealant to threads of screws (35) and install over dowel (30).
11. While sleeve (27) is engaged into dowel on link (28), slide spool (21) into bore of body (16), and through sleeve (27). Spool (21) must move freely and easily at all positions of the link (28).
12. Assemble remaining parts per drawing. While spring retainer is engaging clevis pin (5) under dowel of link (28), slide the other opening of spring retainer over the top of the screw (3). Attach body assembly (16) to cap (1) and torque screws to 75 lb.*ft., 102 Nm.

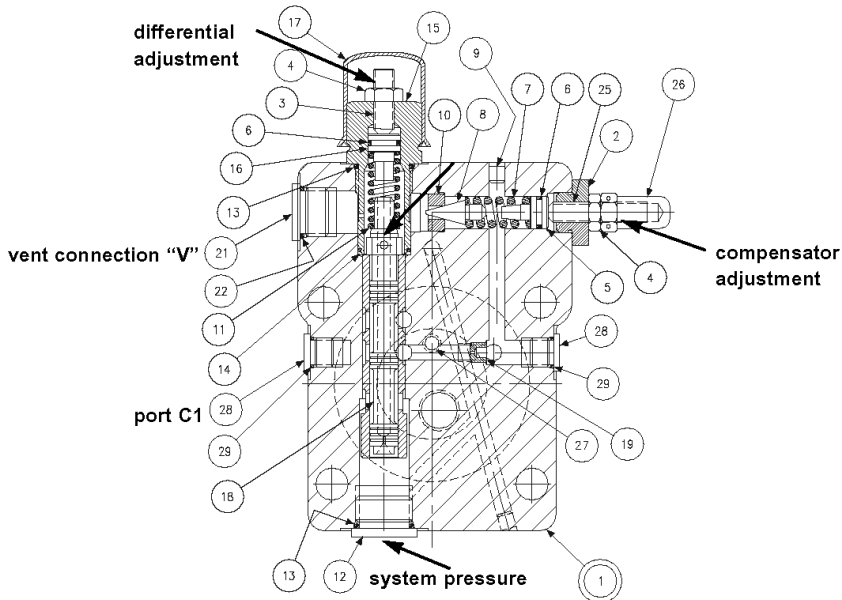

Ref. Figure 10
Torque limiter cap

LOAD SENSING PRESSURE COMPENSATOR CONTROL

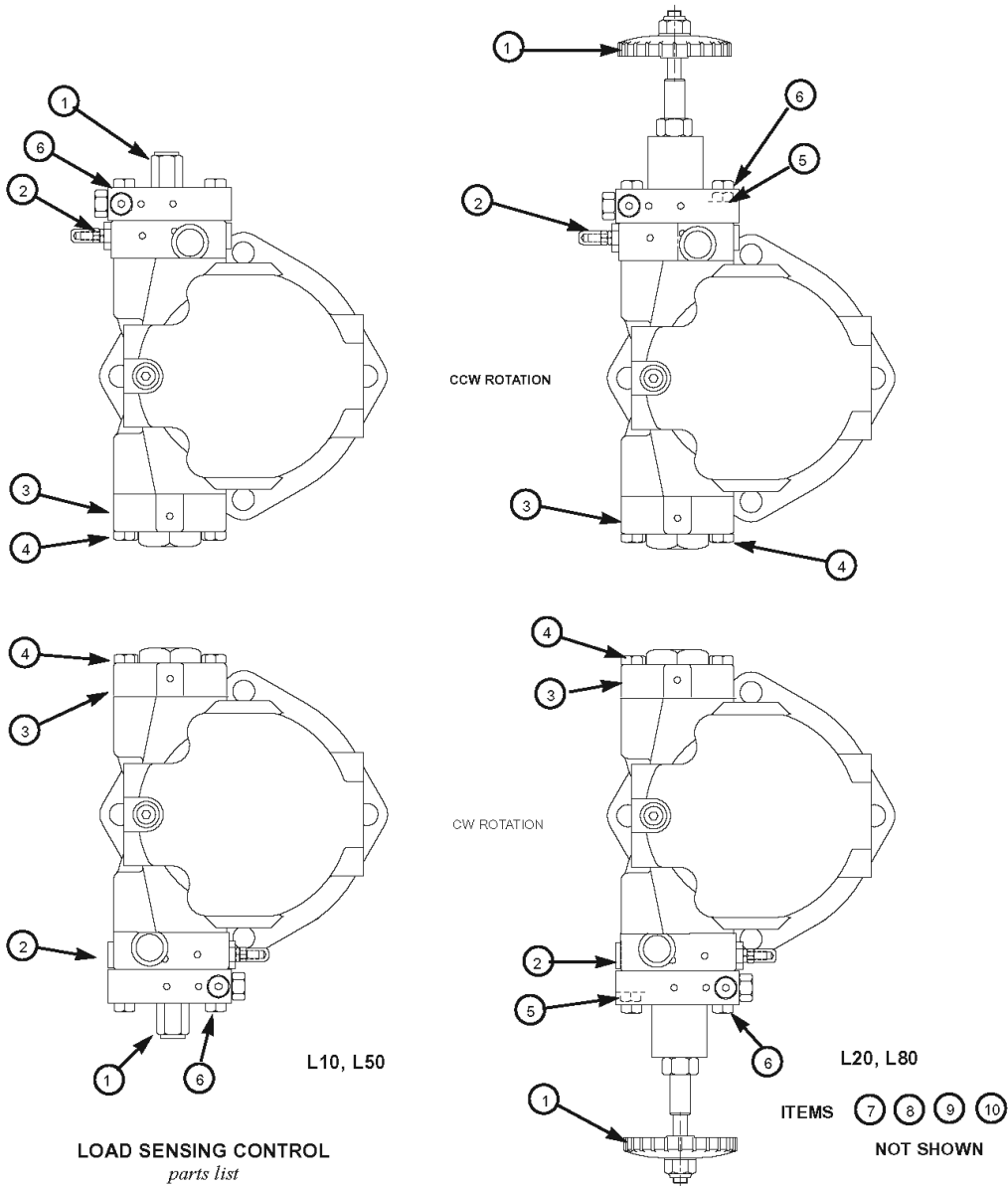

ITEM	DESCRIPTION	P07		P110		QTY.	
		PART NO.	PART NO.	PART NO.	PART NO.	L10, L50, L20, L80	
1	Maximum Volume Stop (Fig. 7)	S22-15467	S22-15467	1	—		
	Maximum Volume Handwheel (Fig. 8)	S22-15448	S22-15448	—	1		
2	*Load Sensing Control (L1*)(Fig. 12)	S22-15402	S22-15625	1	—		
2	*Load Sensing Control (L2*)(Fig. 12)	S22-15628	S22-15637	—	1		
3	Buck Up Cap (Fig. 9)	S22-15447	S22-15447	1	1		
4	Screw-H.H.C..M12 x 55 mm	363-12205	363-12205	6	4		
5	Screw-H.H.C., M12 x 80 mm	363-12225	363-12225	—	2		
6	Screw-H.H.C. M12 x 90 mm	363-12240	363-12240	2	2		
7	Control Piston	032-91836	032-91836	1	1		
8	O-Ring, 90 S-1 ARP 013	691-00013	691-00013	2	2		
9	O-Ring, 70 S-1 ARP 151	671-00151	671-00151	2	2		
10	Piston Ring	032-91816	032-91816	2	2		

*Include items 1 (Maximum Volume Stop), 4, 6, 8 and 9

LOAD SENSING PRESSURE COMPENSATOR CONTROL

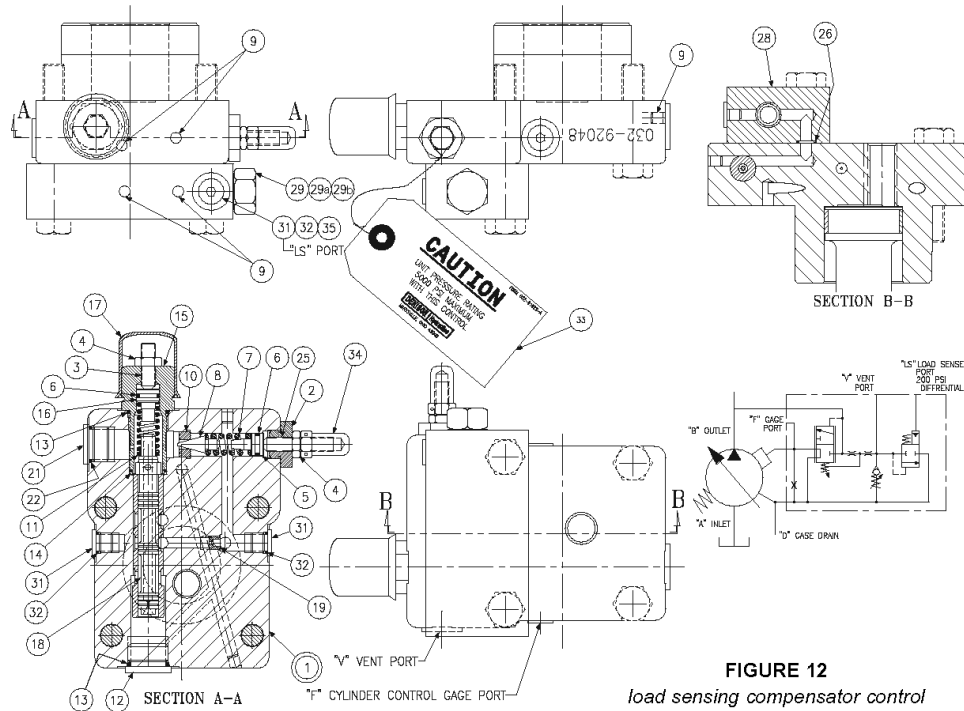

FIGURE 12
load sensing compensator control

PARTS LIST FOR FIGURE 12
LOAD SENSING COMPENSATOR

P07 L1* S22-15402

P07 L2* S22-15628

P110 L1* S22-15625

P110 L2* S22-15637

ITEM	DESCRIPTION	P07		P110	
		PART NO.	QTY	PART NO.	QTY
1	Cap-Sleeve Assembly	S22-15143	1	S22-15176	1
2	Adjusting Plug	032-91814	1	032-91814	1
3	Socket Setscrew	312-13160	1	312-13160	1
4	Nut, 5/16-24	335-13100	2	335-13100	2
5	Seal Piston	031-59367	1	031-59367	1
6	O-Ring, 90 S-1 ARP 012	691-00012	2	691-00012	2
7	Spring	032-91798	1	032-91798	1
8	Cone	036-12288	1	036-12288	1
9	Avseal Plug	447-00026	5	447-00026	5
10	Seat	036-11692	1	036-11692	1
11	Spring	033-71086	1	033-71086	1
12	Plug, SAE-8, 1/2 BSPP	488-35055	1	447-01008	1
13	O-Ring, 90 S-1 ARP 910	691-00910	2	691-00910	1
14	O-Ring, 90 S-1 ARP 017	691-00017	1	691-00017	1
15	Plug	031-57368	1	031-57368	1
16	Seal Piston	032-91305	1	032-91305	1
17	Cap	449-00612	1	449-00612	1
18	Spool	032-59482	1	032-59482	1
19	Orifice, .047", 1.19 mm.	033-25528	1	033-25528	1
21	Plug, SAE-10, 1/2 BSPP	488-35018	1	447-00032	1
22	O-Ring, 90 S-1 ARP 908	691-00908	1	-	-
25	Setscrew 5/16-24 x 1-1/4	312-13180	1	312-13180	1
26	O-Ring, 70 S-1 ARP 011	671-00011	2	671-00011	2
28	Body-Valve	032-91620	1	032-91620	1
29	Isolation Valve Cartridge	517-00063-5	1	517-00063-5	1
29-A	O-Ring 90 S-1 ARP 017	691-00017	2	691-00017	2
29-B	O-Ring 90 S-1 ARP 015	691-00015	1	691-00015	1
31	Plug, SAE-4, 1/4 BSPP	488-35061	2	447-01004	2
32	O-Ring, 90 S-1 ARP 904	691-00904	2	691-00904	1
33	Tag, Caution	032-91622	1	032-91622	1
34	Nut, Acorn	036-33474	1	036-33474	1
35	Adapter	-	-	032-91507	1

LOAD SENSING PRESSURE COMPENSATOR CONTROL

DISASSEMBLY

1. See Figure 12 Back off maximum volume screw or handwheel to full displacement. Remove maximum volume assembly.
2. Remove bolts holding cap to pump.
3. Remove isolation valve (29) from block (28). Remove plug (15) and attached parts. Remove spring (11) and spool (18).
4. Remove adjusting plug (2) and attached parts. Remove seal piston (5). Note: a 10-24 screw may be used to assist in pulling the piston. Remove spring (7) and cone (8).
5. Do not remove sleeve in body (1). Sleeve is pressed into cap and finished to size. If sleeve or cap is worn, replace the cap-sleeve assembly (1).
6. Examine seat (10) for wear. Do not remove unless damaged.

ASSEMBLY

See page 26 for tightening torque on plugs

1. Install Avseal plugs (9) and .047", 1,19 mm. orifice (19) in body.
2. Press seat (10) into bore squarely against shoulder in bore.
3. Install plug (12) and spool (18) into bore as shown. Install spring (11) over end of spool. Install O-ring (6) on seal piston(16). Lubricate and install into plug (15). Install plug (15) into cap. Install screw (3), nut (4) and cover (17).
4. Install O-ring (6) on seal piston (5).
5. Lubricate O-ring and install cone (8), spring (7) and seal piston into bore in cap (1), being careful that cone enters seat (10). Install remaining parts in body (1).
6. Install O-rings (29-a) and (29-b) on valve (29). See Figure 13, page 40. Observe that backup ring on inside groove is toward the outside, the one on the middle groove is toward the inside, and the one on the outside groove is toward the outside. Lubricate and install valve (29) in block (28), being careful to avoid damaging the O-rings. Torque to 50 lb.·ft., 67,8 Nm.
7. For the P110 only, install O-ring (32) on adapter (35). Install adapter in block (28). Install plug (31) in adapter (35). For the P07 only, install O-ring (32) on plug (31). Install plug (31) in block (28).
8. Note proper location for cap on pump (page 24). Install O-rings on interface between cap and pump control pad. Install O-rings (26) in block (28).
9. Install on pump control pad, guiding the control piston into the bore. Install maximum volume stop parts.
10. Torque mounting bolts to 75 lb.·ft., 102 Nm.

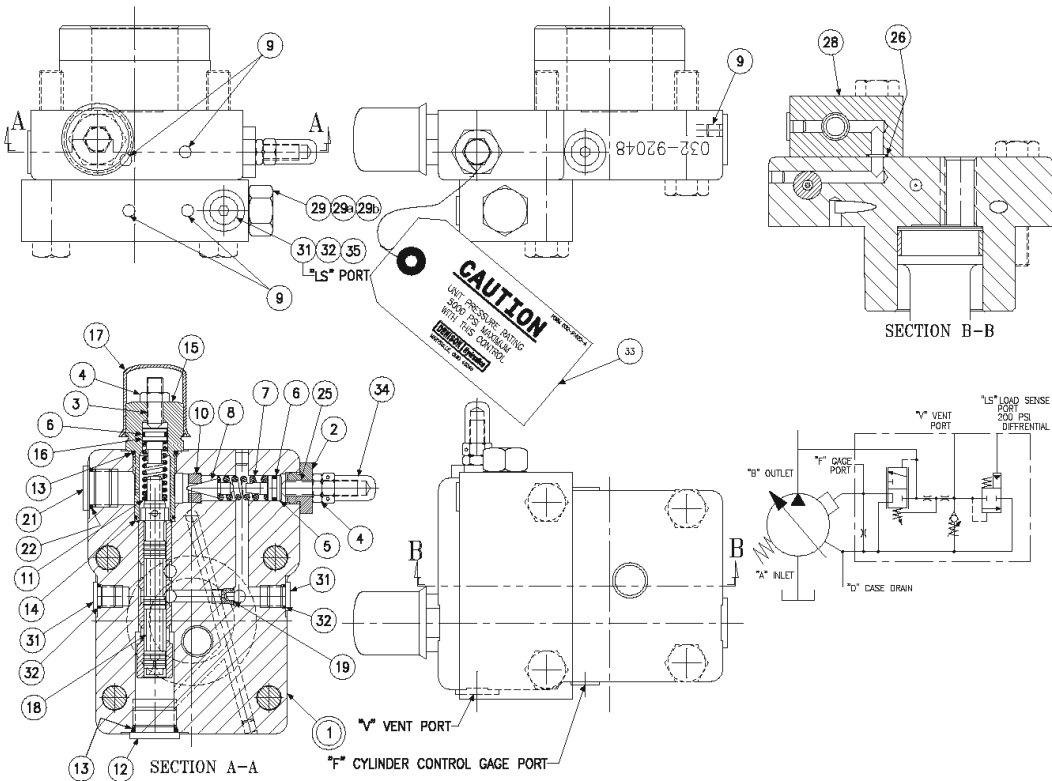

Ref. Figure 12
load sensing compensator control

LOAD SENSING TORQUE LIMITER CONTROL

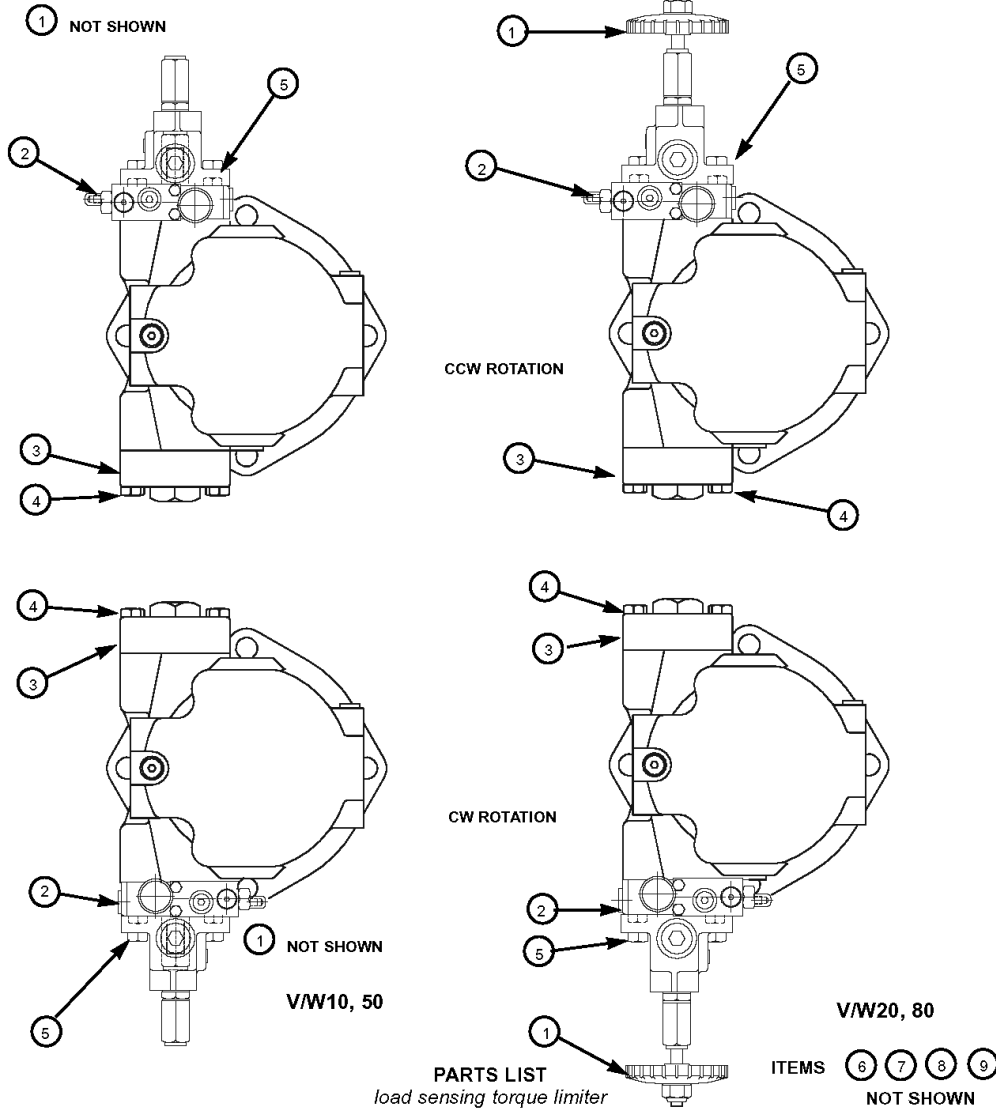

ITEM DESCRIPTION	P07	P110	QUANTITY			
	PART NO	PART NO.	V10*	W10*	V20**	W20**
1 Maximum Volume Stop (Fig. 7)	S22-15467	S22-15467	1	1	—	—
Maximum Volume Handwheel (Fig. 8)	S22-15448	S22-15448	—	—	1	1
2 ***Low Torque Limiter Load Sensing (V10)(Fig. 13)	S22-16186	S22-16188	1	—	—	—
2 ***Low Torque Limiter Load Sensing (V20)(Fig. 13)	S22-16195	S22-16196	—	—	1	—
***High Torque Limiter Load Sensing (W10)(Fig. 13)	S22-16187	S22-16189	—	1	—	—
***High Torque Limiter Load Sensing (W20)(Fig. 13)	S22-16197	S22-16198	—	—	—	1
3 Buck Up Cap (Fig. 9)	S22-15447	S22-15447	1	1	1	1
4 Screw-H.H.C., M12 x 55 mm	363-12205	363-12205	6	6	4	4
5 Screw-H.H.C., M12 x 80 mm	363-12225	363-12225	2	2	4	4
6 Control Piston	032-91836	032-91836	1	1	1	1
7 O-Ring, 90 S-1 ARP 013	691-00013	691-00013	2	2	2	2
8 O-Ring, 70 S-1 ARP 151	671-00151	671-00151	2	2	2	2
9 Piston ring	032-91816	032-91816	2	2	2	2

* Also V50, W50 **Also V80, W80 ***Includes items 1, 4, 5, 7 and 8

LOAD SENSING TORQUE LIMITER CONTROL

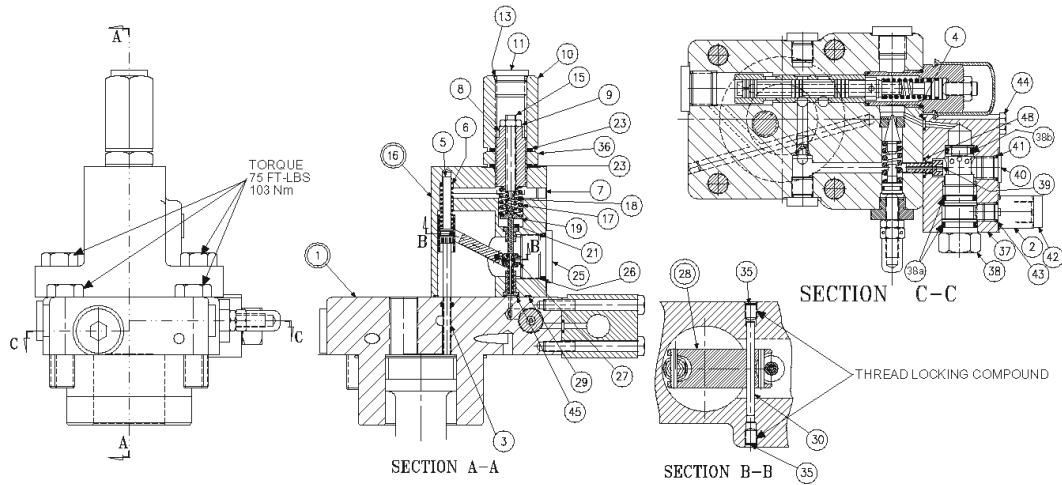

FIGURE 13

Load Sensing Torque Limiter

PARTS LIST FOR FIGURE 13

P07 code V10, V50, S22-16186
 P07 code W10, W50, S22-16187
 P110 code V10, V50, S22-16188
 P110 code W10, W50, S22-16189

ITEM	DESCRIPTION	P07		P110		QTY.	
		PART NO.	PART NO.	V	W		
1	Cap (Figure 14)	S22-16177	S22-16179	1	1		
2	Adapter	-	032-91507	1	1		
3	Screw	032-91461	032-91461	1	1		
5	Clevis pin	321-40000	321-40000	1	1		
6	Spring, Compression	032-92100	032-92100	1	1		
7	Plug, Avseal	447-00026	447-00026	1	1		
8	Screw	032-91445	032-91445	1	1		
9	Nut, Hex Jam 1/4-20 UNC	340-00038	340-00038	1	1		
10	Hex Nut, 3/4-16 UNF	032-91449	032-91449	1	1		
11	Plug, SAE-8	488-35018	488-35018	1	1		
13	O-Ring, 90 S-1 ARP 908	691-00908	691-00908	1	1		
15	Screw, Primary Adjusting	032-91446	032-91446	1	1		
16	Body assembly	S22-15396	S22-15396	1	1		
17	Outer Spring - V Version	032-91440	032-91440	1	—		
	Outer Spring - W Version	032-91440	032-91440	—	1		
18	Inner Spring - V Version	032-92240	032-92240	1	—		
	Inner Spring - W Version	032-91441	032-91441	—	1		
19	Spring Retainer	032-91819	032-91819	1	1		
21	Spool	032-91438	032-91438	1	1		
23	O-ring, 70 S-1 ARP 118	671-00118	671-00118	2	2		
25	Plug, 12 SAE-12	488-35014	488-35014	1	1		
26	O-Ring, 90 S-1 ARP 912	691-00912	691-00912	1	1		
27	Sleeve	032-91437	032-91437	1	1		
28	Arm assembly	S22-15520	S22-15520	1	1		
29	O-Ring, 70 S-1 ARP 035	671-00035	671-00035	1	1		
30	Dowel Pin, 1/8 Dia. x 1.50 Lg	324-20824	324-20824	1	1		
35	Screw, SHC 10-32 x 1/4	312-09041	312-09041	2	2		
36	Nut	032-91645	032-91645	1	1		
37	Body, load sense	032-92359	032-92359	1	1		
38	Valve, modulating	517-00063-5	517-00063-5	1	1		
38a	O-ring, 90 S-1 ARP 017	691-00017	691-00017	2	2		
38b	O-ring, 90 S-1 ARP 015	691-00015	691-00015	1	1		
39	Screw, special	033-70908	033-70908	1	1		
40	Plug, SAE-6	488-35003	488-35003	1	1		
41	O-ring, 90 S-1 ARP 906	691-00906	691-00906	1	1		
42	Plug, SAE-4, 1/4 BSPP	488-35013	447-01004	1	1		
43	O-ring, 90 S-1 ARP 904	691-00904	691-00904	1	1		
44	Screw, HHC, 1/4-20x2-1/4	306-40187	306-40187	2	2		
45	O-Ring, 70 S-1 ARP 010	671-00010	671-00010	1	1		
48	O-Ring, 70 S-1 ARP 012	671-00012	671-00012	1	1		

LOAD SENSING TORQUE LIMITER CONTROL

DISASSEMBLY

1. See Figure 13. Remove 2 screws holding torque limiter body (16) to cap assembly (1).
2. Remove all parts from torque limiter body (16) except pin (30) and arm assembly (28). It is not necessary to remove these parts unless broken or worn. Examine parts for wear or damage.
3. Remove screw (3). Examine head for excessive wear, and body for smooth sealing surface with O-ring.
4. Remove maximum stop handwheel assembly or maximum stop screw assembly.
5. Remove modulating valve (38) from body (37). Remove body (37) from cap assembly (1). Note plug (40) must be removed to remove special screw (39). Remove cap assembly (1).
1. See Figure 14. Remove plug (15) and attached parts. Remove spring (11) and spool (18).
2. Remove adjusting plug (2) and attached parts. Remove seal piston (5). Note: a 10-24 screw may be used to assist in pulling the piston. Remove spring (7) and cone (8).
3. Do not remove sleeve in body (1). Sleeve is pressed into cap and finished to size. If sleeve or cap is worn, replace the cap-sleeve assembly (1).
4. Examine seat (10) for wear. Do not remove unless damaged.

ASSEMBLY

See page 26 for tightening torque on plugs

1. See Figure 14. Install Avseal plug (9) and .047", 1,19 mm. orifice (19) in body.
2. Press seat (10) into bore squarely against shoulder in bore.
3. Install plug (12) and spool (18) into bore as shown. Install spring (11) over end of spool. Install O-ring (6) on seal piston (16). Lubricate and install into plug (15). Install plug (15) into cap. Install screw (3), nut (4) and cover (17).
4. Install O-ring (6) on seal piston (5).
5. Lubricate O-ring and install cone (8), spring (7) and seal piston into bore in cap (1), being careful that cone enters seat (10). Install remaining parts in body (1).
6. Note proper location for cap on pump (pg.24). Install O-rings on interface between cap and pump control pad
7. Install on pump control pad, guiding the control piston into the bore. Install maximum volume stop or handwheel parts.
8. See Figure 13. Install block (37) on cap (1) with O-rings (4) and (48). Use special screw (39) through the block.
7. Install O-rings (38a) and (38b) on valve (38). Observe that backup ring on inside groove is toward the outside, the one on the middle groove is toward the inside, and the one on the outside groove is toward the outside. Lubricate and install valve (38) in block (37), being careful to avoid damaging the O-rings. Torque to 50 lb.*ft., 67,8 Nm.
7. For the P110 only, install O-ring (43) on adapter (2). Install adapter in block (37). Install plug (31) in adapter (35). For the P07 only, install O-ring (43) on plug (42). Install plug (42) in block (37).
- 8.. Apply thread locking compound on threads of screw (3), lubricate the shank, thread through the cap into the control piston, and torque to 5 lb.*ft., 6,8 Nm
9. Measure height from control cap to top of screw. With control piston at full displacement, dimension must be 1.50 +/- .03 in., 38,1 +/- 0,76 mm.
10. Press dowel (30) into body (16), through the link assembly (28), to 1/4", 6,35 mm below surface. Apply hydraulic sealant to threads of screws (35) and install over dowel (30).
11. While sleeve (27) is engaged into dowel on link (28), slide spool (21) into bore of body (16), and through sleeve (27). Spool (21) must move freely and easily at all positions of the link (28).
12. Assemble remaining parts per drawing. While spring retainer is engaging clevis pin (5) under dowel of link (28), slide the other opening of spring retainer over the top of the screw (3). Attach body assembly (16) to cap (1) and torque mounting screws to 75 lb.*ft., 102 Nm.

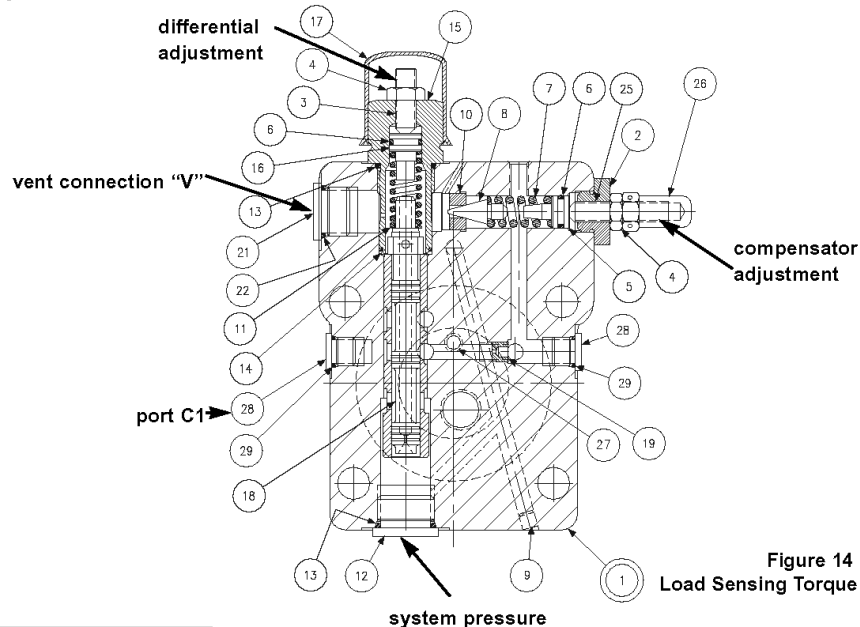
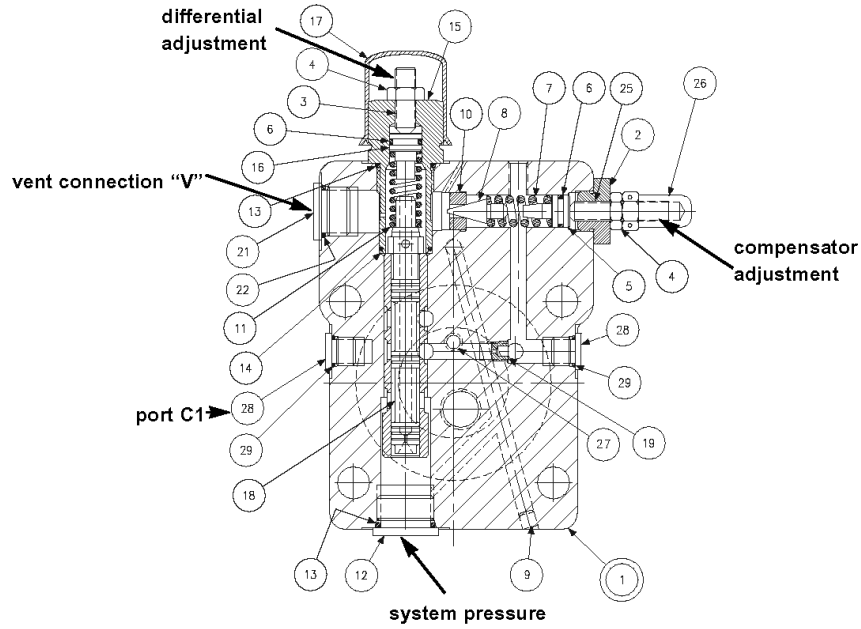

Figure 14
Load Sensing Torque limiter cap

LOAD SENSING TORQUE LIMITER CONTROL



Ref. Figure 14
Load Sensing Torque limiter cap

PARTS LIST FOR FIGURE 14
P07 load sensing torque limiter cap
 S22-16177
P110 load sensing torque limiter cap
 S22-16179

ITEM	DESCRIPTION	P07		P110	
		PART NO.	QTY	PART NO.	QTY
1	Cap-Sleeve Assembly	S22-16178	1	S22-16180	1
2	Adjusting Plug	032-91814	1	032-91814	1
3	Socket Setscrew 5/16-24 x 1	312-13160	1	312-13160	1
4	Nut, 5/16-24	335-13100	2	335-13100	2
5	Seal Piston	031-59367	1	031-59367	1
6	O-Ring, 90 S-1 ARP 012	691-00012	2	691-00012	2
7	Spring	032-91798	1	032-91798	1
8	Cone	036-12288	1	036-12288	1
9	Avseal Plug	447-00026	1	447-00026	1
10	Seat	036-11692	1	036-11692	1
11	Spring	033-71086	1	033-71086	1
12	Plug	488-35055	1	447-01008	1
13	O-Ring, 90 S-1 ARP 910	691-00910	2	691-00910	1
14	O-Ring, 90 S-1 ARP 017	691-00017	1	691-00017	1
15	Plug	031-57368	1	031-57368	1
16	Seal Piston	032-91305	1	032-91305	1
17	Cap	449-00612	1	449-00612	1
18	Spool	032-59482	1	032-59482	1
19	Orifice, .047", 1,19 mm.	033-25528	1	033-25528	1
21	Plug	488-35018	1	447-00032	1
22	O-ring, 70 S-1 ARP 908	691-00908	1	-	-
25	Setscrew, 5/16-24 x 1-1/4	312-13180	1	312-13180	1
26	Nut, Acorn 5/16-24	036-33474	1	036-33474	1
27	O-Ring, 70 S-1 ARP 008	671-00008	1	671-00008	1
28	Plug	488-35061	2	447-01004	2
29	O-ring 90 S-1 ARP 904	691-00904	2	-	-

ROTARY SERVO CONTROL

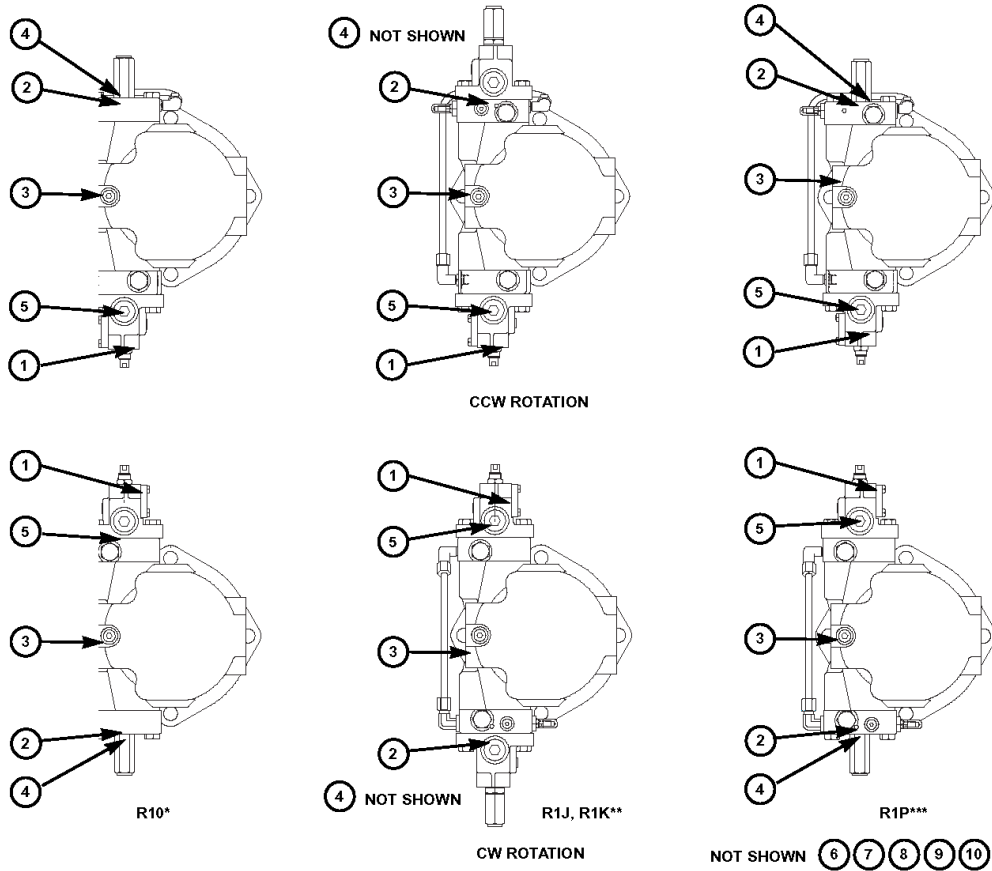

PARTS LIST

rotary servo

ITEM	DESCRIPTION	P07	P110	QUANTITY			
		PART NO.	PART NO.	R10*	R1J**	R1K**	R1P***
1	#Rotary Servo (Fig. 15)	S22-16200	S22-16199	1	1	1	1
2	#Control Cap (Fig.26)	S22-15325	S22-15613	1	—	—	—
	#Low Torque Override (Fig. 29)	S22-16207	S22-16208	—	1	—	—
	#High Torque Override (Fig. 29)	S22-16209	S22-16210	—	—	1	—
	#Compensator Override (Fig. 27)	S22-16205	S22-16206	—	—	—	1
3	Tube Assembly, CW rotation (Fig. 24)	S22-16035	S22-16037	1	1	1	1
	Tube Assembly, CCW rotation (Fig. 25)	S22-16036	S22-16038				
4	Screw-H.H.C., M12 x 55 mm	363-12205	363-12205	6	4	4	6
5	Screw-H.H.C., M12 x 80 mm	363-12225	363-12225	2	4	4	2
6	Control Piston	032-91848	032-91848	1	1	1	1
7	O-Ring, 90 S-1 ARP 013	691-00013	691-00013	2	2	2	2
8	O-Ring, 70 S-1 ARP 151	671-00151	671-00151	2	2	2	2
9	Piston Ring	032-91816	032-91816	1	1	1	1
10	Piston Ring	032-91811	032-91811	1	1	1	1

*Also R50

**Also R5J, R5K

***Also R5P

#Includes items 4, 5, 7 and 8

ROTARY SERVO CONTROL

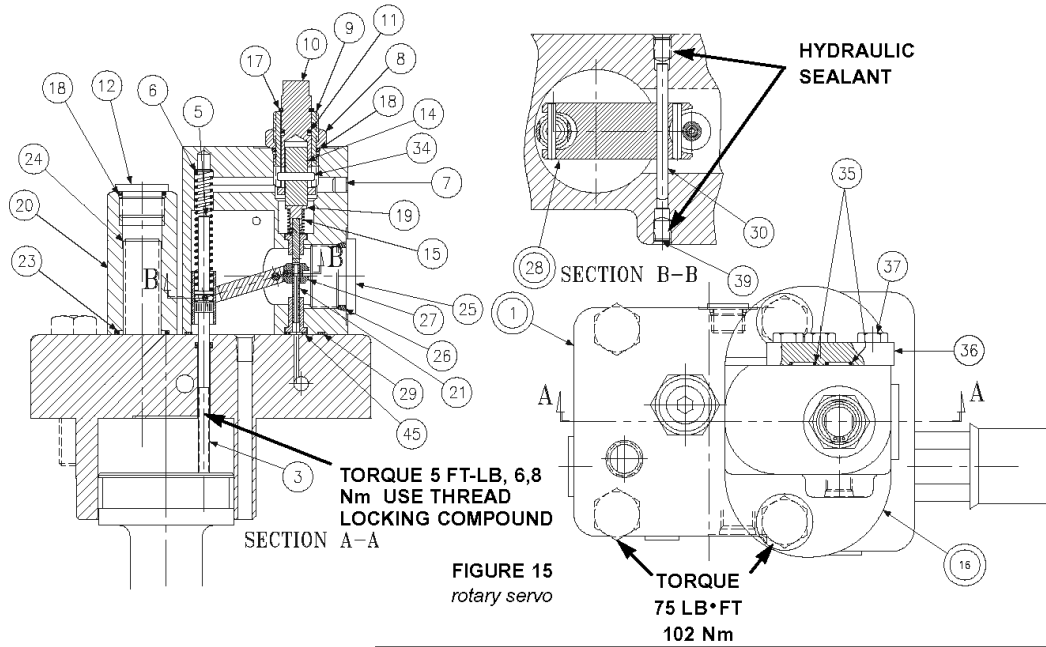

FIGURE 15
rotary servo

PARTS LIST FOR FIGURE 15
ROTARY SERVO
P07 S22-16200
P110 S22-16199

ITEM	DESCRIPTION	P07		P110	
		PART NO.	QTY.	PART NO.	QTY.
1	Cap (Figure 16)	S22-16063	1	S22-16064	1
3	Screw	032-91461	1	032-91461	1
5	Pin, Clevis	321-40000	1	321-40000	1
6	Spring, Compression	032-92100	1	032-92100	1
7	Plug, Avseal	447-00026	1	447-00026	1
8	Locknut	492-15116	1	492-15116	1
9	Cam	032-91515	1	032-91515	1
10	Shaft	032-91514	1	032-91514	1
11	O-Ring, 90 S-1 ARP 012	691-00012	1	691-00012	1
12	Plug, 10HP5N-S	488-35055	1	488-35055	1
13	O-Ring, 90 S-1 ARP 910	691-00910	1	691-00910	1
14	Slide Pin	032-91513	1	032-91513	1
15	Spring	225-92105	1	225-92105	1
16	Body	S22-15393	1	S22-15393	1
17	Retaining Ring	356-31050	1	356-31050	1
18	O-Ring, 90 S-1 ARP 908	691-00908	1	691-00908	1
19	Spring Retainer	032-91516	1	032-91516	1
20	Nut, M16	032-91822	1	031-91049	1
21	Spool	032-91438	1	032-91438	1
23	O-Ring, 70 S-1 ARP 118	671-00115	1	671-00115	1
24	Setscrew, M16(2P)x80mm	311-50001	1	311-50001	1
25	Plug, 12 HP5N-S	488-35014	1	488-35014	1
26	O-Ring, 90 S-1 ARP 912	691-00912	1	691-00912	1
27	Sleeve	032-91437	1	032-91437	1
28	Arm assembly	S22-15520	1	S22-15520	1
29	O-Ring, 70 S-1 ARP 035	671-00035	1	671-00035	1
30	Dowel Pin, 1/8 Dia x 1.50 Lg.	324-20824	1	324-20824	1
33	O-Ring, 70 S-1 ARP 904	671-00904	1	671-00904	1
34	Dowel Pin, 1/8 x 5/8	324-20810	1	324-20810	1
35	O-Ring, 70 S-1 ARP 011	671-00011	2	671-00011	2
36	Plate	032-91510	1	032-91510	1
37	Screw, HHC, 1/4 -20 x 3/4	306-40142	3	306-40142	3
38	Plug, SAE-4	488-35061	1	488-35061	1
39	Screw, SHC 10-32 x 1/4	312-09041	2	312-09041	2
45	O-Ring, 70 S-1 ARP 010	671-00010	1	671-00010	1

ROTARY SERVO CONTROL

DISASSEMBLY

1. See Figure 15. Remove 2 screws holding body (16) to cap assembly (1).
2. Remove all parts from body (16) except pin (30) and arm assembly (28). It is not necessary to remove these parts unless broken or worn. Examine parts for wear or damage.
3. Remove screw (3). Examine head for excessive wear, and body for smooth sealing surface with O-ring.
4. See Figure 16. Remove tube lines to cap assembly.
5. Remove screws holding cap assembly to pump body.
6. Remove cap assembly (1). Remove plug (4) with attached parts. Remove spring (11) and spool (6).
7. Do not remove sleeve in body (1). Sleeve is pressed into cap and finished to size. If sleeve or cap is worn, replace the cap-sleeve assembly (1).
8. Remove screw (13) and nut (14). Push a rod through the cap to remove the retainer (7).

ASSEMBLY

See page 26 for tightening torque on plugs

1. See Figure 16. Install Avseal plug (9) in cap.
2. Install spool (6) into bore as shown. Install spring (11) over end of spool.
3. Install O-ring (8) on spring retainer (7). Install retainer (7), screw (13) and nut (14) in plug (4).
4. Install O-rings (10) and (15) on plug (4). Install plugs (4) and (12) in body (1). Install .047", 1,19 mm orifice (19), and .071", 1,98 mm orifice (20), and plugs (2) and (17). Torque plugs. Install O-ring (21) in cap.
5. Turn screw (13) in until spring retainer (17) contacts spring (11). Turn an additional 1-1/2 turns and lock in position.
6. Note proper location for control on pump (pg. 24). Install O-rings on interface between cap and pump control pad. Install cap on pump control pad, guiding the control piston into the bore.
7. Torque two assembly bolts to 75 lb.*ft., 102 N m.
8. See Figure 15. Apply thread sealing compound on threads of screw (3), lubricate the shank, thread through the cap into the control piston, and torque to 5 lb.*ft., 6,78 N m.
9. Install minimum stop screw (24) and turn clockwise to by two springs, one which is always in contact with the pin, and the other comes in contact as pressure increases, to provide an increase in spring rate as pressure increases. Stroke pump to full displacement.. Measure height from control cap to top of screw (3). With control piston at full displacement, dimension must be .74 +/- .03 in., 18,8 +/- 0,76 mm. Back out minimum stop screw (24) till there is no contact with control piston.
10. Press dowel (30) into body (16), through the link (28), to 1/4 in., 6,35 mm below surface. Apply hydraulic sealant to threads of screws (39) and install over dowel (30).
11. Press spool (21) into retainer (19). Caution: do not use excessive force.
12. While sleeve (27) is engaged into dowel on link (28), slide above spool assembly with spring (15) into bore of body (16), and through sleeve (27). Spool (21) must move freely and easily at all positions of the link (28).
13. Press dowel (34) through slide pin (14), while inside shaft (10). Dowel (34) must evenly extend from both sides of slide pin (14).
14. Assemble all other components into body (16) per Figure 15. Torque plug (12)
15. While spring retainer is engaging clevis pin (5) under dowel of link (28), slide the other opening of spring retainer over the top of the screw (3). Attach body assembly (16) to cap (1) with two screws and torque to 75 lb.*ft., 103 N m.

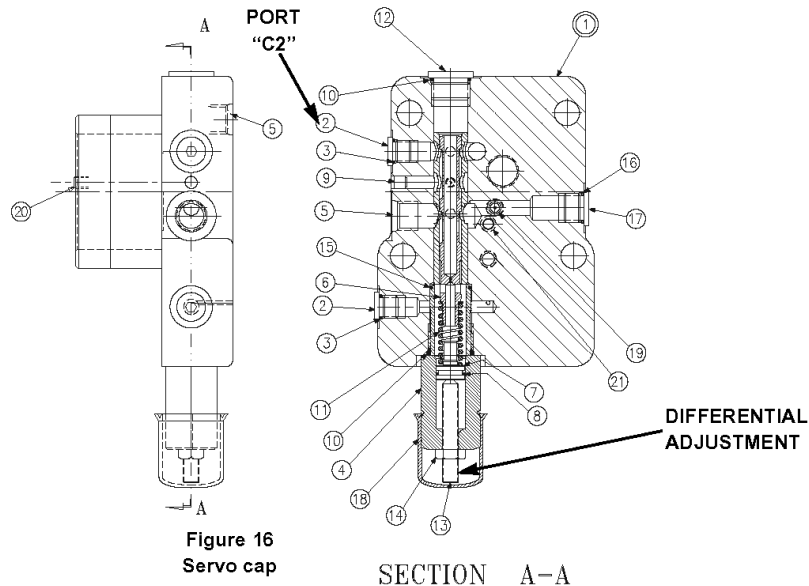
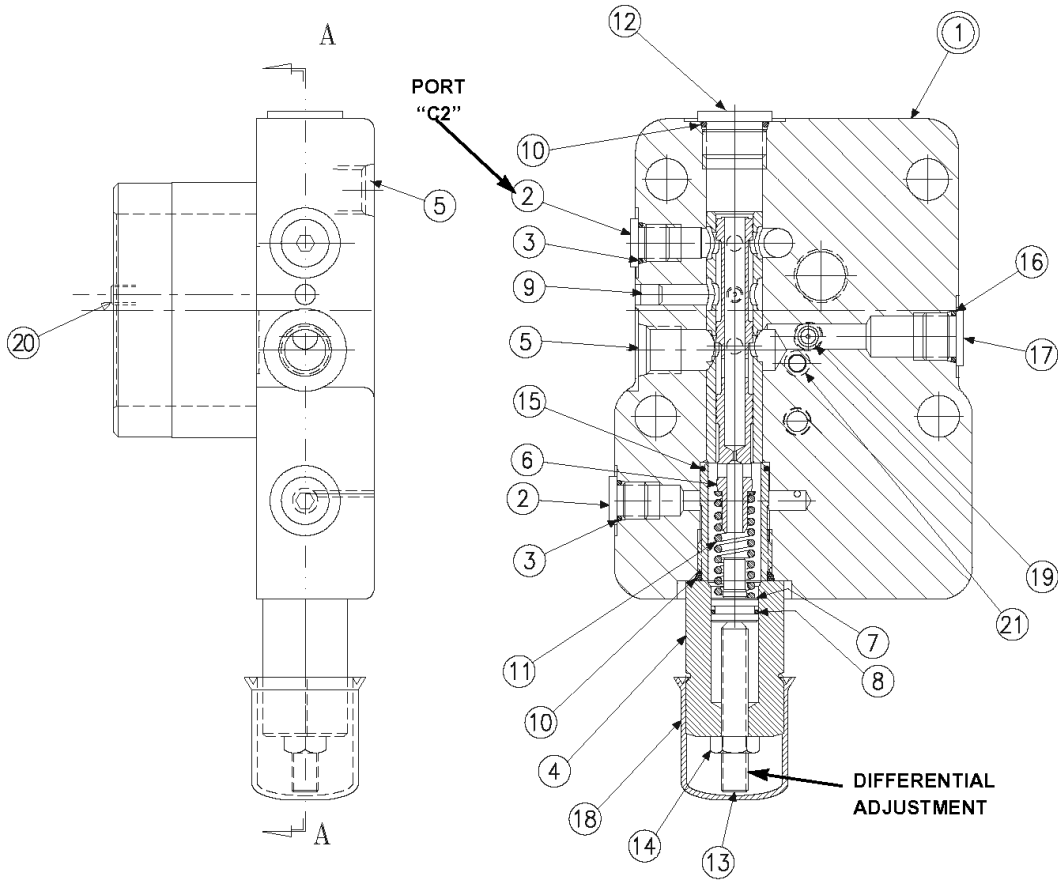

Figure 16
Servo cap

SECTION A-A

ROTARY SERVO CONTROL



Ref. Figure 16
Servo cap

SECTION A-A

PARTS LIST FOR FIGURE 16

P07 servo cap S22-16063
P110 servo cap S22-16064

ITEM	DESCRIPTION	P07		P110	
		PART NO.	QTY	PART NO.	QTY.
1	Cap/Sleeve	S22-16065	1	S22-16066	1
2	Plug, SAE-4, 1/4 BSPP	488-35061	2	447-01004	1
3	O-ring, 90 S-1 ARP 904	691-00904	2	--	-
4	Plug	032-91861	1	032-91861	1
5	Plug	449-00015	1	449-00599	1
6	Spool	032-92409	1	032-92409	1
7	Spring retainer	032-92550	1	032-92550	1
8	O-Ring, 90 S-1 ARP 013	691-00013	1	691-00013	1
9	Avseal Plug	447-00026	1	447-00026	1
10	O-Ring, 90 S-1 ARP 910	691-00910	2	691-00910	1
11	Spring	032-92098	1	032-92098	1
12	Plug, SAE-10, 1/2 BSPP	488-35018	1	447-01008	1
13	Screw, 5/16 -24 x 2	312-35062	1	312-35062	1
14	Nut, 5/16-24	335-13100	1	335-13100	1
15	O-Ring, 90 S-1 ARP 017	691-00017	1	691-00017	1
16	O-Ring, 90 S-1 ARP 906	691-00906	1	--	--
17	Plug, SAE-6, 3/8 BSPP	488-35041	1	447-00032	1
18	Cap	449-00612	1	449-00612	1
19	Orifice, .047", 1.19 mm	033-25528	1	033-25528	1
20	Orifice, .078", 1.98 mm	032-92399	1	032-92399	1
21	O-Ring, 70 S-1 ARP 008	671-00008	1	671-00008	1

HYDRAULIC STROKER CONTROL

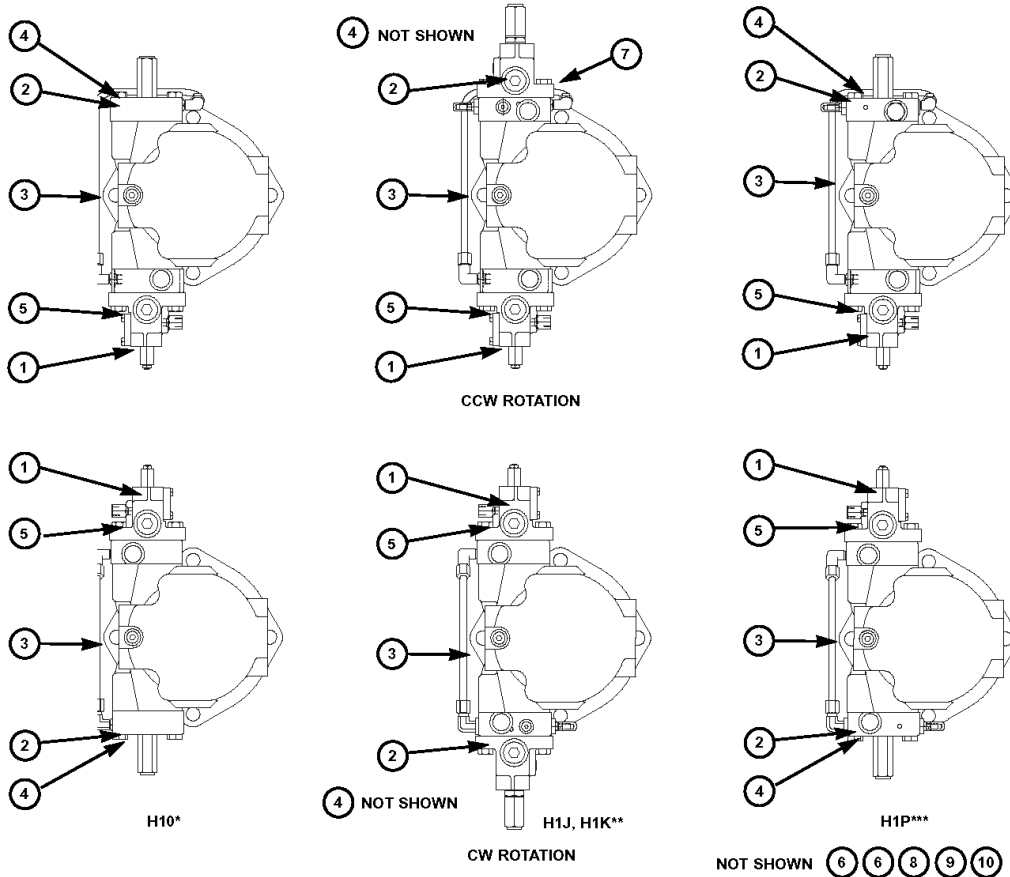

PARTS LIST *hydraulic stroker*

ITEM	DESCRIPTION	P110		QUANTITY			
		PART NO.	PART NO.	H10*	H1J**	H1K**	H1P***
1	#Hydraulic Stroker (Fig. 17)	S22-16202	S22-16201	1	1	1	1
2	#Control Cap (Fig. 26)	S22-15325	S22-15613	1	—	—	—
	#Low Torque Override (Fig. 29)	S22-16207	S22-16208	—	1	—	—
	#High Torque Override (Fig. 29)	S22-16209	S22-16210	—	—	1	—
	#Compensator Override (Fig. 27)	S22-16205	S22-16206	—	—	—	1
3	Tube Assembly, CW rotation (Fig. 24)	S22-16035	S22-16037	1	1	1	1
	Tube Assembly, CCW rotation (Fig. 25)	S22-16036	S22-16038	—	—	—	—
4	Screw-H.H.C., M12 x 55 mm	363-12205	363-12205	6	4	4	6
5	Screw-H.H.C., M12 x 80 mm	363-12225	363-12225	2	4	4	2
6	Control Piston	032-91848	032-91848	1	1	1	1
7	O-Ring, 90 S-1 ARP 013	691-00013	691-00013	2	2	2	2
8	O-Ring, 70 S-1 ARP 151	671-00151	671-00151	2	2	2	2
9	Piston Ring	032-91816	032-91816	1	1	1	1
10	Piston Ring	032-91811	032-91811	1	1	1	1

*Also H50

**Also H5J, H5K

***Also H5P

#Includes items 4, 5, 7 and 8

HYDRAULIC STROKER CONTROL

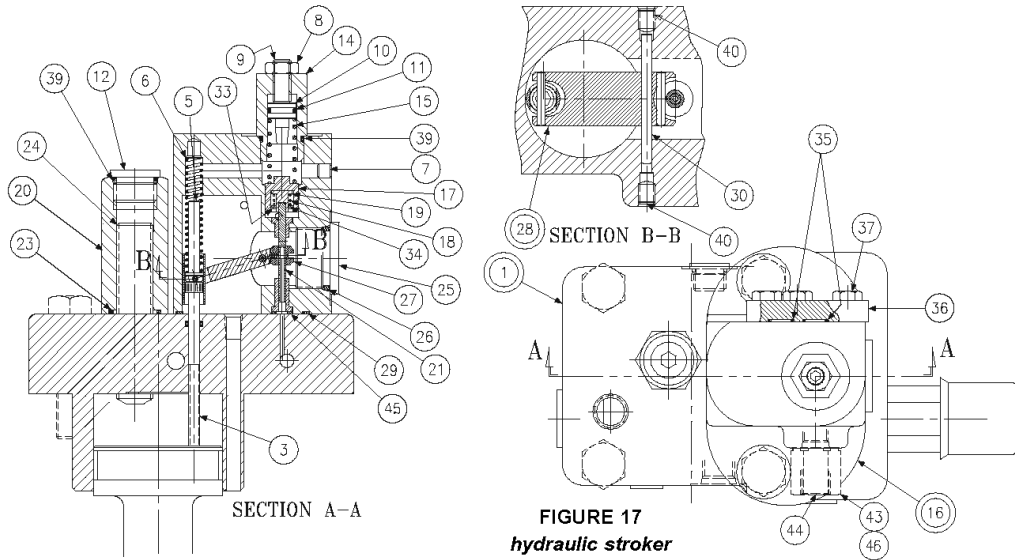

PARTS LIST FOR FIG. 17
P07 hydraulic stroker S22-16202
P110 hydraulic stroker S22-16201

ITEM	DESCRIPTION	P07		P110	
		PART NO.	QTY.	PART NO.	QTY.
1	Cap (Figure 16)	S22-16063	1	S22-16064	1
3	Screw	032-91461	1	032-91461	1
5	Clevis pin	321-40000	1	321-40000	1
6	Spring, Compression	032-92100	1	032-92100	1
7	Plug, Avseal	447-00026	1	447-00026	1
8	Nut, 5/16-24	335-13100	1	335-13100	1
9	Setscrew, 5/16-24 x 1-1/4	312-13180	1	312-13180	1
10	Seal Piston	032-91918	1	032-91918	1
11	O-Ring, 90 S-1 ARP 012	691-00012	1	691-00012	1
12	Plug, 10HP5N-S	488-35055	1	488-35055	1
14	Spring Cap	032-91511	1	032-91511	1
15	Spring	225-92101	1	225-92101	1
16	Body	S22-15393	1	S22-15393	1
17	Spool	032-91512	1	032-91512	1
18	Spring	225-92109	1	225-92109	1
19	Spring Retainer	032-91516	1	032-91516	1
20	Nut, 3/4-10	031-91049	1	031-91049	1
21	Spool	032-91438	1	032-91438	1
23	O-Ring, 70 S-1 ARP 118	671-00118	1	671-00118	1
24	Socket Setscrew, 3/4-10 x 3	311-26320	1	311-26320	1
25	Plug, SAE-12	488-35014	1	488-35014	1
26	O-Ring, 90 S-1 ARP 912	691-00912	1	691-00912	1
27	Sleeve	032-91437	1	032-91437	1
28	Arm assembly	S22-15520	1	S22-15520	1
29	O-Ring, 70 S-1 ARP 035	671-00035	1	671-00035	1
30	Dowel Pin, 1/8 Dia x 1.50 Lg.	324-20824	1	324-20824	1
33	Retaining Ring	356-30037	1	356-30037	1
34	Washer	032-91517	1	032-91517	1
35	O-Ring, 70 S-1 ARP 011	671-00011	2	671-00011	2
36	Plate	032-91510	1	032-91510	1
37	Screw, HHC, 1/4-20 x 3/4	306-40142	3	306-40142	3
39	O-Ring, 90 S-1 ARP 908	691-00908	1	691-00908	1
40	Screw, SHC 10-32 x 1/4	312-09041	2	312-09041	2
43	Fitting	-	-	032-91507	1
44	Seal	-	-	449-00603	1
45	O-Ring, 70 S-1 ARP 010	671-00010	1	671-00010	1
46	O-ring, 90 S-1 ARP 904	-	-	691-00904	1

HYDRAULIC STROKER CONTROL

DISASSEMBLY

1. See figure 17. Remove 2 screws holding body (16) to cap assembly (1).
2. Remove all parts from body (16) except pin (30) and arm assembly (28). It is not necessary to remove these parts unless broken or worn. Examine parts for wear or damage.
3. Remove screw (3). Examine head for excessive wear, and body for smooth sealing surface with O-ring.
4. See figure 16. Remove tube lines to cap assembly.
5. Remove screws holding cap assembly to pump body.
6. Remove cap assembly (1). Remove plug (4) with attached parts. Remove spring (11) and spool (6).
7. Do not remove sleeve in body (1). Sleeve is pressed into cap and finished to size. If sleeve or cap is worn, replace the cap-sleeve assembly (1).
8. Remove screw (13) and nut (14). Push a rod through the cap to remove the retainer (77).

ASSEMBLY

See page 26 for tightening torque on plugs

1. See figure 16. Install Avseal plug (9) in cap.
2. Install spool (6) into bore as shown. Install spring (11) over end of spool.
3. Install O-ring (8) on spring retainer (7). Install retainer (7), screw (13), and nut (14) in plug (4).
4. Install O-rings (10) and (15) on plug (4). Install plugs (4) and (12) in body (1). Install .047", 1.19 mm orifice (19), and .071", 1.98 mm orifice (20) and plugs (2) and (17). Torque plugs. Install O-ring (21) in cap.
5. Turn screw (13) in until spring retainer (7) contacts spring (11). Turn an additional 1-1/2 turns and lock in position.
6. Note proper location for control on pump (pg. 24). Install O-rings on interface between cap and pump control pad. Install cap on pump control pad, guiding the control piston into the bore.
7. Torque two assembly bolts to 75 lb.*ft., 102 Nm.
8. See figure 17. Apply thread locking compound on threads of screw (3), lubricate the shank, thread through the cap into the control piston, and torque to 5 lb.*ft., 6.78 Nm.
9. Install minimum stop screw (24) and turn clockwise to stroke pump to full volume. Measure height from control cap to top of screw (3). With control piston at full displacement, dimension must be .74 +/- .03 in., 18.8 +/- 0.76 mm. Back out minimum stop screw (24) till there is no contact with control piston.
10. Press dowel (30) into body (16), through the link (28), to 1/4", 6.35 mm below surface. Apply hydraulic sealant to threads of screws (40) and install over dowel (30).
11. Press spool (21) into retainer (19). Caution: do not use excessive force. Place spool/retainer assembly into spool (17) with spring (18) and washer (34). Secure with retaining ring (33).
12. While sleeve (27) is engaged into dowel on link (28), slide above spool assembly into bore of body (16), and through sleeve (27). Spool (21) must move freely and easily at all positions of the link (28).
13. Assemble all other components into body (16) per above drawing. Torque plug (12).
14. While spring retainer is engaging clevis pin (5) under dowel of link (28), slide the other opening of spring retainer over the top of the screw (3). Attach body assembly (16) to cap (1) with two screws and torque to 75 lb.-ft., 102 Nm.
15. Install tubing assembly (Figure 24, 25).

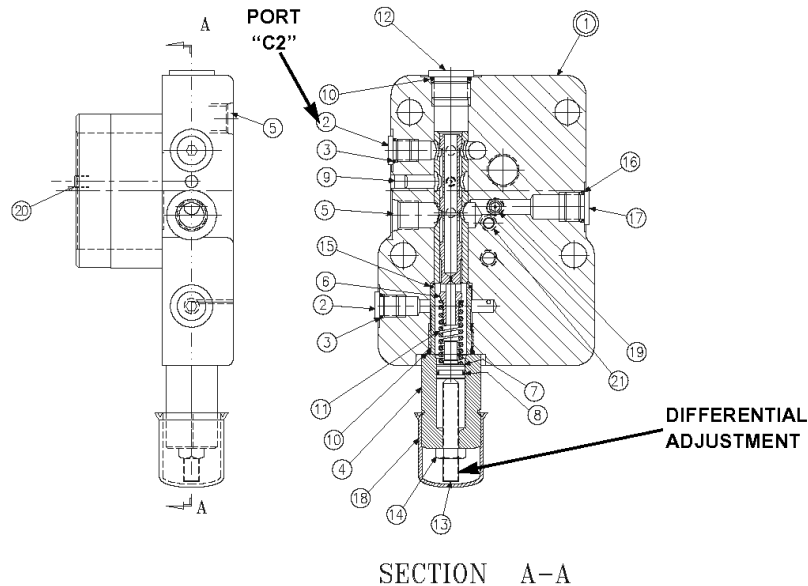

ref. Figure 16
SERVO CAP

ELECTROHYDRAULIC STROKER CONTROL

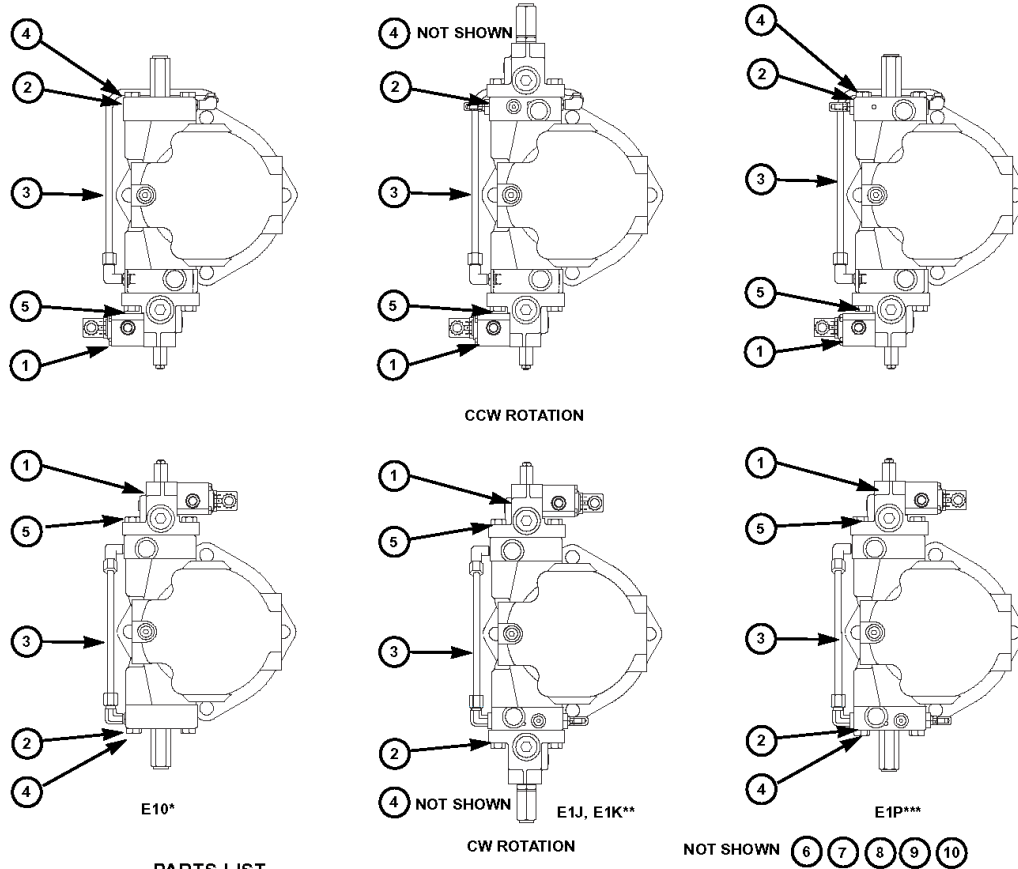

PARTS LIST
electrohydraulic stroker

ITEM	DESCRIPTION	P07	P110	QUANTITY			
		PART NO.	PART NO.	E10*	E1J**	E1K**	E1P***
1	#Electrohydraulic Stroker (Fig. 18)	S22-16057	S22-16060	1	1	1	1
2	#Control Cap (Fig.26)	S22-15325	S22-15613	1	—	—	—
	#Low Torque Override (Fig. 29)	S22-16207	S22-16208	—	1	—	—
	#High Torque Override (Fig. 29)	S22-16209	S22-16210	—	—	1	—
	#Compensator Override (Fig. 27)	S22-16205	S22-16206	—	—	—	1
3	Tube Assembly, CW rotation (Fig. 24)	S22-16035	S22-16037	1	1	1	1
	Tube Assembly, CCW rotation (Fig. 25)	S22-16036	S22-16038				
4	Screw-H.H.C., M12 x 55 mm	363-12205	363-12205	6	4	4	6
5	Screw-H.H.C., M12 x 80 mm	363-12225	363-12225	2	4	4	2
6	Control Piston	032-91848	032-91848	1	1	1	1
7	O-Ring, 90 S-1 ARP 013	691-00013	691-00013	2	2	2	2
8	O-Ring, 70 S-1 ARP 151	671-00151	671-00151	2	2	2	2
9	Piston Ring	032-91816	032-91816	1	1	1	1
10	Piston Ring	032-91811	032-91811	1	1	1	1

*Also E50

**Also E5J, E5K

***Also E5P

#Includes items 4, 5, 7 and 8

ELECTROHYDRAULIC STROKER CONTROL

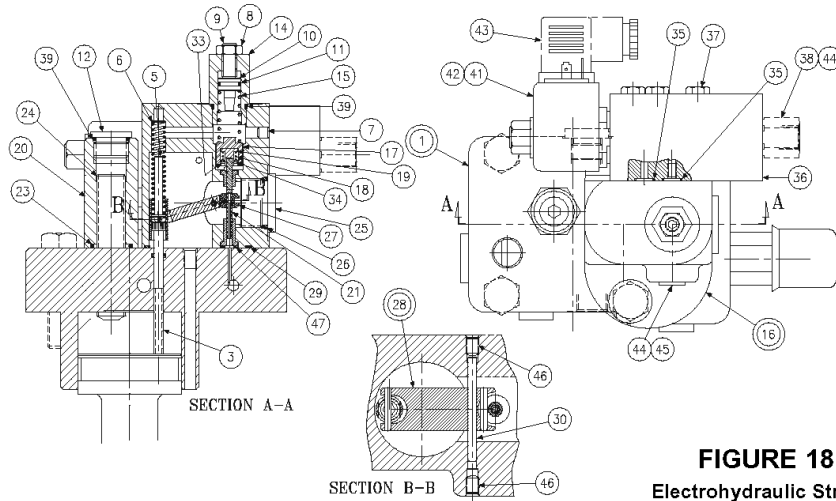

FIGURE 18
Electrohydraulic Stroker

PARTS LIST FOR FIGURE 18

P07 electrohydraulic stroker
S22-16204
P110 electrohydraulic stroker
S22-16203

ITEM	DESCRIPTION	P07		P110	
		PART NO.	QTY.	PART NO.	QTY.
1	Cap (Figure 16)	S22-16063	1	S22-16064	1
3	Screw	032-91461	1	032-91461	1
5	Clevis pin	321-40000	1	321-40000	1
6	Spring, Compression	032-92100	1	032-92100	1
7	Plug, Avseal	447-00026	1	447-00026	1
8	Nut, 5/16-24	335-13100	1	335-13100	1
9	Setscrew, 5/16-24 x 1-1/4	312-13180	1	312-13180	1
10	Seal Piston	032-91918	1	032-91918	1
11	O-Ring, 90 S-1 ARP 012	691-00012	1	691-00012	1
12	Plug, SAE-8	488-35018	1	488-35018	1
14	Spring Cap	032-91511	1	032-91511	1
15	Spring	225-92101	1	225-92101	1
16	Body	S22-15393	1	S22-15393	1
17	Spool	032-91512	1	032-91512	1
18	Spring	225-92109	1	225-92109	1
19	Spring Retainer	032-91516	1	032-91516	1
20	Nut, M16	031-91822	1	031-91822	1
21	Spool	032-91438	1	032-91438	1
23	O-Ring, 70 S-1 ARP 115	671-00115	1	671-00115	1
24	Socket Setscrew, M16	311-50001	1	311-50001	1
25	Plug, SAE-12	488-35014	1	488-35014	1
26	O-Ring, 90 S-1 ARP 912	691-00912	1	691-00912	1
27	Sleeve	032-91437	1	032-91437	1
28	Arm assembly	S22-15520	1	S22-15520	1
29	O-Ring, 70 S-1 ARP 035	671-00035	1	671-00035	1
30	Dowel Pin, 1/8 Dia x 1.50 Lg.	324-20824	1	324-20824	1
33	Retaining Ring	356-30037	1	356-30037	1
34	Washer	032-91517	1	032-91517	1
35	O-Ring, 70 S-1 ARP 011	671-00011	2	671-00011	2
36	Block	032-91509	1	032-91509	1
37	Screw, 1/4-20 x 2-1/4	306-40187	3	306-40187	3
38	Adapter	-	-	032-91507	1
39	O-Ring, 90 S-1 ARP 908	691-00908	1	691-00908	1
41	Proportional Pressure Valve	517-00095	1	517-00095	1
42	Coil, 24VDC	517-00096	1	517-00096	1
	Coil, 12VDC	517-00097		517-00097	
43	Connector	167-01008-8		167-01008-8	1
44	O-Ring, 90 S-1 ARP 904	691-00904	1	691-00904	2
45	Plug, SAE-4	488-35061	1	488-35061	1
46	Screw, SHC 10-32 x 1/4	312-09041	2	312-09041	2
47	O-Ring, 70 S-1 ARP 010	671-00010	1	671-00010	1

DISASSEMBLY

1. See Figure 18. Remove 3 screws (37) holding block (36) to body (16).
2. Remove 2 screws holding body (16) to cap assembly (1).
3. Remove all parts from body (16) except pin (30) and arm assembly (28). It is not necessary to remove these parts unless broken or worn. Examine parts for wear or damage.
4. Remove screw (3). Examine head for excessive wear, and body for smooth sealing surface with O-ring.
5. See Figure 16. Remove tube lines to cap assembly.
6. Remove screws holding cap assembly to pump body.
7. Remove cap assembly (1). Remove plug (4) with attached parts. Remove spring (11) and spool (6).
8. Do not remove sleeve in body (1). Sleeve is pressed into cap and finished to size. If sleeve or cap is worn, replace the cap-sleeve assembly (1).
9. Remove screw (13) and nut (14). Push a rod through the cap to remove the retainer (7).

ASSEMBLY

See page 26 for tightening torque on plugs

1. See Figure 16. Install Avseal plug (9) in cap.
2. Install spool (6) into bore as shown. Install spring (11) over end of spool.
3. Install O-ring (8) on spring retainer (7). Install retainer (7), screw (13), and nut (14) in plug (4).
4. Install O-rings (10) and (15) on plug (4). Install plugs (4) and (12) in body (1). Install .047", 1.19 mm orifice (19), and .071", 1.98 mm orifice, (20) and plugs (2) and (17). Torque plugs. Install O-ring (21) in cap.
5. Turn screw (13) in until spring retainer (7) contacts spring (11). Turn an additional 1-1/2 turns and lock in position.
6. Note proper location for control on pump (pg 24). Install O-rings on interface between cap and pump control pad. Install cap on pump control pad, guiding the control piston into the bore.
7. Torque two assembly bolts to 75 lb.*ft., 102 N m.
8. See Figure 18. Apply thread locking compound on threads of screw (3), lubricate the shank, thread through the cap into the control piston, and torque to 5 lb.*ft., 6.78 N * m.
9. Install minimum stop screw (24) and turn clockwise to stroke pump to full volume. Measure height from control cap to top of screw (3). With control piston at full displacement, dimension must be .74 +/- .03 in., 18.8 +/- 0.76 mm. Back out minimum stop screw (24) till there is no contact with control piston.
10. Press dowel (30) into body (16), through the link (28), to 1/4, 6.35 mm below surface, apply hydraulic sealant to threads of screws (46) and install over dowel (30).
11. Press spool (21) into retainer (19). Caution: do not use excessive force. Place spool/retainer assembly into spool (17) with spring (18) and washer (34). Secure with retaining ring (33).
12. While sleeve (27) is engaged into dowel on link (28), slide above spool assembly into bore of body (16), and through sleeve (27). Spool (21) must move freely and easily at all positions of the link (28).
13. Install proportional valve (41) in block. Torque to 20 ft.*lbs., 27 N m.
14. Install coil on proportional valve. Torque to 20-25 in.*lbs., 2.2-2.8 N m maximum
15. Assemble all other components into body (16) per above drawing. Torque the plug (12).
16. While spring retainer is engaging clevis pin (5) under dowel of link (28), slide the other opening of spring retainer over the top of the screw (3). Attach body assembly (16) to cap (1) with two screws and torque to 75 lb.*ft., 102 N m.
17. Install tubing assembly (Figure 24, 25).

Figure 16
Servo cap

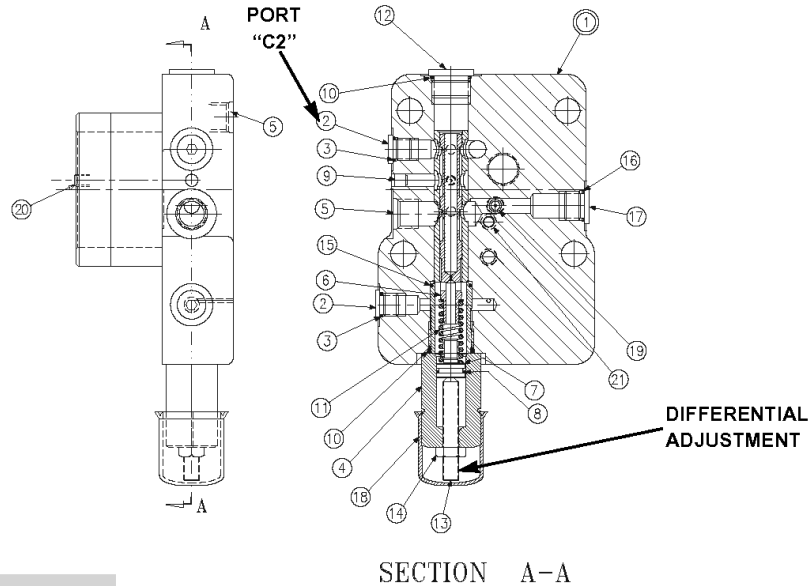

ADJUST FOR ZERO FLOW AT
175 MA ELECTRICAL COMMAND

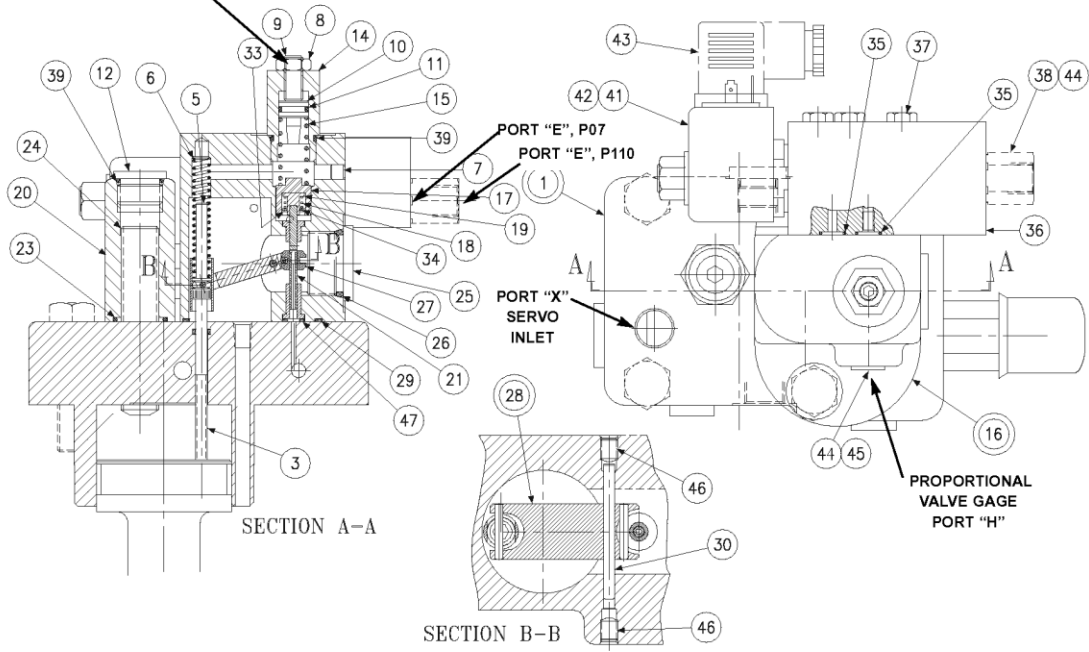

Ref. Figure 18
ELECTROHYDRAULIC STROKER

PQ CONTROL
IN PROCESS OF DEVELOPMENT

PQ CONTROL
IN PROCESS OF DEVELOPMENT

PQ CONTROL
IN PROCESS OF DEVELOPMENT

PQ CONTROL
IN PROCESS OF DEVELOPMENT

SECONDARY CONTROLS

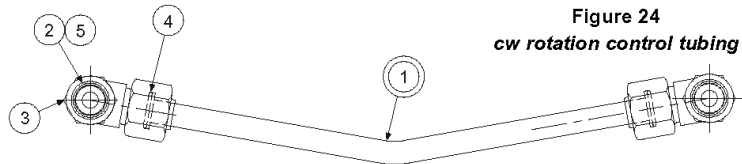

Figure 24
cw rotation control tubing

PARTS LIST FOR FIGURE 24

cw rotation control tubing S22-16035 (P07) S22-16037 (P110)

ITEM	DESCRIPTION	P07 PART NO.	P110 PART NO.	QTY.
1	Servo tube w/nut & sleeve	S22-16032	S22-16077	1
2	O-ring, 90 S-1	691-00906	691-00113	2
3	Elbow fitting	492-15382	492-15426	2
4	O-ring, 90 S-1 ARP 012	691-00012	691-00012	2
5	Fitting retaining ring	-	492-15417	2

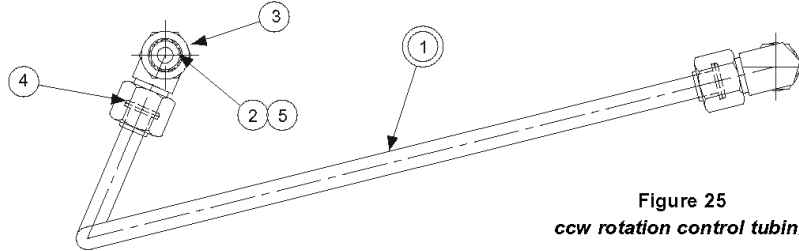

Figure 25
ccw rotation control tubing

PARTS LIST FOR FIGURE 25

ccw rotation control tubing S22-16036 (P07) S22-16038 (P110)

ITEM	DESCRIPTION	P07 PART NO.	P110 PART NO.	QTY.
1	Servo tube w/nut & sleeve	S22-16076	S22-16078	1
2	O-ring, 90 S-1	691-00906	691-00113	2
3	Elbow fitting	492-15382	492-15426	2
4	O-ring, 90 S-1 ARP 012	691-00012	691-00012	2
5	Fitting retaining ring	-	492-15417	2

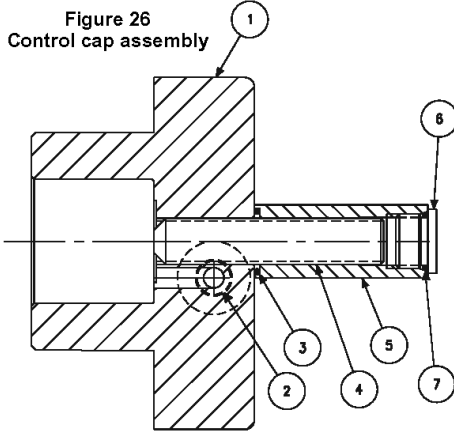

Figure 26
Control cap assembly

CONTROL CAP DISASSEMBLY

1. See Figure 26. Remove nut (5) and maximum volume screw (4).
2. Remove 4 screws holding cap to pump.
3. Remove cap assembly from pump.

ASSEMBLY

See page 26 for tightening torque on plugs

1. Install O-rings on interface between cap and pump control pad. Install cap on pump housing as indicated on the applicable view (pg. 24), guiding the control piston into the bore.
2. Torque the assembly bolts to 75 lb.*ft., 102 Nm.
3. Install screw (4) in cap. Install O-ring (3) on nut (5). Install nut (5) on screw.
4. Adjust screw till pump is slightly on stroke and lock nut (5).
5. Install O-ring (7) on plug (6). Install plug in nut (5). Torque plug (6).

PARTS LIST FOR FIGURE 26

P07 control cap assembly S22-15325
P110 control cap assembly S22-15613

ITEM	DESCRIPTION	P07		P110	
		PART NO.	QTY.	PART NO.	QTY.
1	Control Cap	032-91842	1	032-92229	1
2	Plug	449-00015	1	449-00599	1
3	O-ring, 70 S-1 ARP 115	671-00115	1	671-00115	1
4	Screw, M16	311-50001	1	311-50001	1
5	Nut, M16	031-91822	1	031-91822	1
6	Plug, SAE-8	488-35018	1	488-35018	1
7	O-ring 90 S-1 ARP 908	691-00908	1	691-00908	1

COMPENSATOR OVERRIDE CONTROL

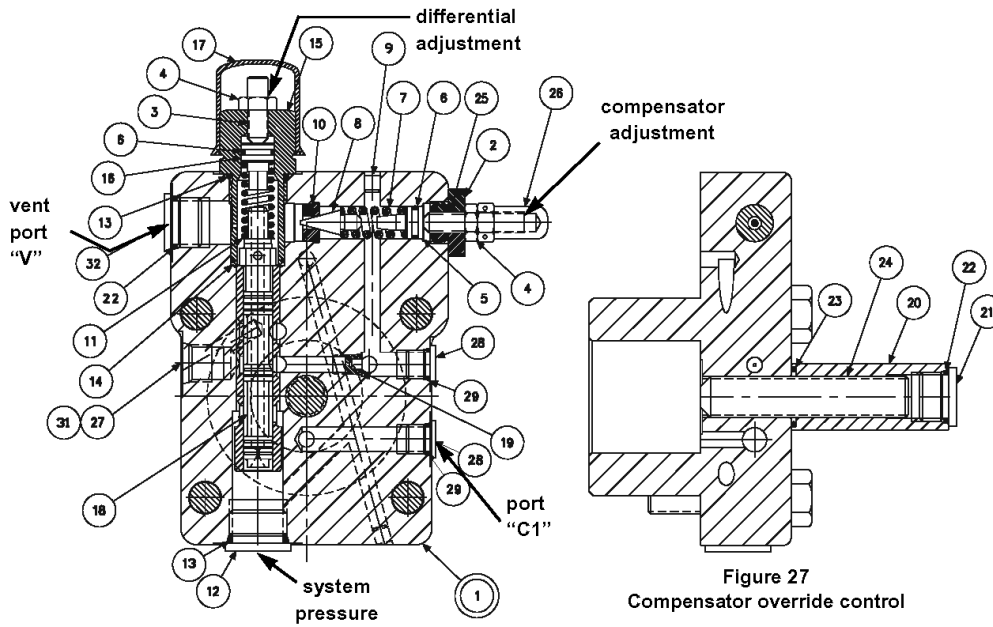

Figure 27
Compensator override control

PARTS LIST FOR FIGURE 27
compensator override control
P07 compensator override S22-16205
P110 comp. override S22-16206

ITEM	DESCRIPTION	P07		P110	
		PART NO.	QTY.	PART NO.	QTY.
1	Cap-Sleeve Assembly	S22-16043	1	S22-16044	1
2	Adjustment Plug	032-91814	1	032-91814	1
3	Socket Setscrew 5/16-24 x 1	312-13160	1	312-13160	1
4	Nut, 5/16-24	335-13100	2	335-13100	2
5	Seal Piston	031-59367	1	031-59367	1
6	O-Ring, 90 S-1 ARP 012	691-00012	2	691-00012	2
7	Spring	032-91798	1	032-91798	1
8	Cone	036-12288	1	036-12288	1
9	Avseal Plug	447-00026	2	447-00026	2
10	Seat	036-11692	1	036-11692	1
11	Spring	225-92101	1	225-92101	1
12	Plug, SAE-10, 1/2 BSPP	488-35055	1	447-01008	1
13	O-Ring, 90 S-1 ARP 910	691-00910	2	691-00910	1
14	O-Ring, 90 S-1 ARP 017	691-00017	1	691-00017	1
15	Plug	031-57368	1	031-57368	1
16	Seal piston	032-92480	1	032-92480	1
17	Cap	449-00612	1	449-00612	1
18	Spool	032-92549	1	032-92549	1
19	Plug, 1/16 NPTF	431-90104	1	431-90104	1
20	Nut, M16	032-91822	1	032-91822	1
21	Plug	488-35018	1	488-35018	1
22	O-ring, 90 S-1 ARP 908	691-00908	2	691-00908	1
23	O-ring, 70 S-1 ARP 115	671-00115	1	671-00115	1
24	Socket. Setscrew, M16	311-50001	1	311-50001	1
25	Socket Setscrew 5/16-24	312-13180	1	312-13180	1
26	Acorn Nut	036-33474	1	036-33474	1
27	Plug	449-00015	1	449-00599	1
28	Plug, SAE-4, 1/4 BSPP	488-35061	2	447-01004	2
29	O-ring, 90 S-1 ARP 904	691-00904	2	447-00032	2
31	Orifice	035-40489	1	035-40489	1
32	Plug, SAE-8, 3/8 BSPP	488-35018	1	447-00032	1

COMPENSATOR OVERRIDE CONTROL

DISASSEMBLY

1. See Figure 27. Remove tube line to cap.
2. Remove maximum volume stop assembly (items 20, 21, 22, 23, 24).
3. Remove cap assembly.
4. Remove plug (15) and attached parts. Remove spring (11) and spool (18).
5. Remove adjusting plug (2) and attached parts. Remove seal piston (5). Note: a 10-24 screw may be attached to assist in pulling the piston. Remove spring (7) and cone (8).
6. Do not remove sleeve in body (1). Sleeve is pressed into cap and finished to size. If sleeve, snout or cap is worn, replace the cap-sleeve assembly (1).
7. Examine seat (10) for wear. Do not remove unless damaged.

ASSEMBLY

See page 26 for tightening torque on plugs

1. Install Avseal plugs (9) in body. Install .032", 0,81 mm orifice (31) as indicated. Install plug (19) as shown.
2. Press seat (10) into bore to shoulder in bore.
3. Install spool (18) into bore as shown. Install spring (11) over end of spool. Install O-ring (6) on seal piston (16). Lubricate and install into plug (15). Install O-rings (13) and (14) on plug (15). Install plug (15) into cap. Install screw (3), nut (4) and cover (17).
4. Install O-ring (6) on seal piston (5).
5. Lubricate O-ring and install cone (8), spring (7) and seal piston into bore in cap (1), being careful that cone enters seat (10).
6. Install remaining parts. Torque plugs (12) (21) (28) and (32).
7. Note proper location for cap on pump (pg. 24). Install O-rings on interface between cap and pump control pad.
8. Install cap assembly on pump, guiding the control piston into the bore.
9. Torque mounting bolts to 75 lb.*ft., 102 N.m.
10. Install tubing assembly (Figure 24, 25).

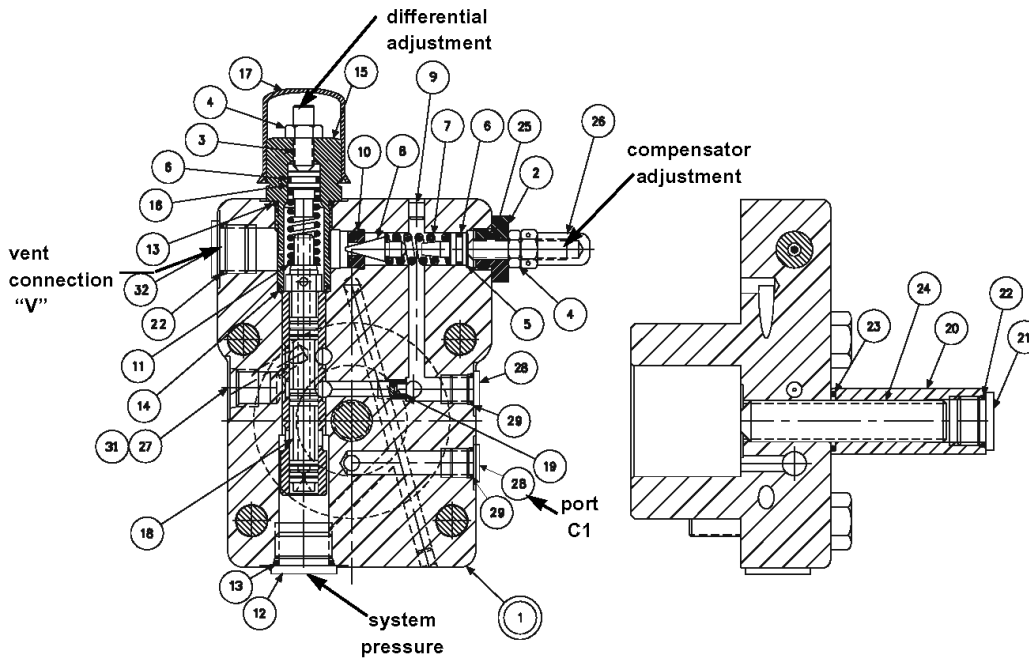

Ref. Figure 27
COMPENSATOR OVERRIDE CONTROL

TORQUE LIMITER OVERRIDE

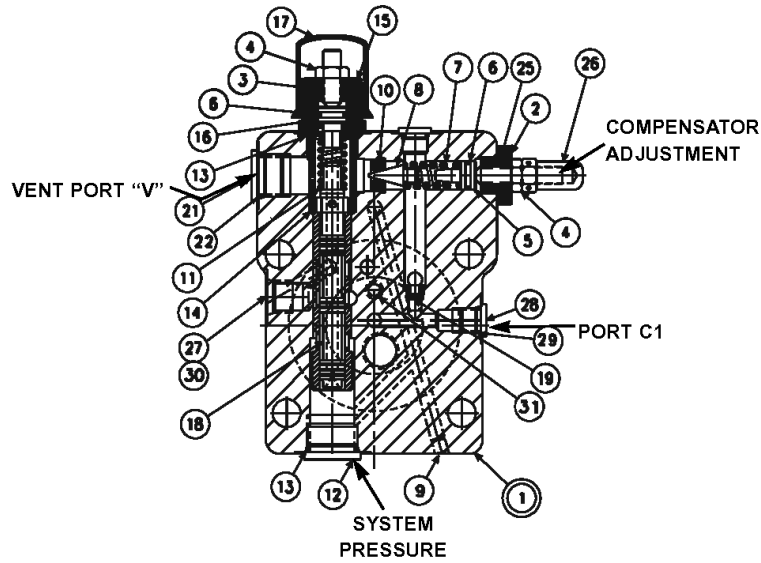

FIGURE 28
torque limiter override cap

PARTS LIST FOR FIGURE 28
torque limiter override cap
P07 cap S22-16049
P110 cap S22-16050

ITEM	DESCRIPTION	P07		P110	
		PART NO.	QTY.	PART NO.	QTY.
1	Cap-Sleeve Assembly	S22-16045	1	S22-16046	1
2	Adjustment. Plug	032-91814	1	032-91814	1
3	Socket Setscrew 5/16-24 x 1	312-13160	1	312-13160	1
4	Nut, 5/16-24	335-13100	2	335-13100	2
5	Seal Piston	031-59367	1	031-59367	1
6	O-Ring, 90 S-1 ARP 012	691-00012	2	691-00012	2
7	Spring	032-91798	1	032-91798	1
8	Cone	036-12288	1	036-12288	1
9	Avseal Plug	447-00026	2	447-00026	2
10	Seat	036-11692	1	036-11692	1
11	Spring	225-92101	1	225-92101	1
12	Plug, SAE-10, 1/2 BSPP	488-35055	1	447-01008	1
13	O-Ring, 90 S-1 ARP 910	691-00910	2	691-00910	1
14	O-Ring, 90 S-1 ARP 017	691-00017	1	691-00017	1
15	Plug	031-57368	1	031-57368	1
16	Seal Piston	032-92480	1	032-92480	1
17	Cap	449-00612	1	449-00612	1
18	Spool	032-92549	1	032-92549	1
19	Plug	431-90104	1	431-90104	1
21	Plug, SAE-8, 3/8 BSPP	488-35018	1	447-00032	1
22	O-ring 90 S-1 ARP 908	691-00908	1	-	-
23	Socket Setscrew	312-13180	1	312-13180	1
25	Acorn Nut	036-33474	1	036-33474	1
26	Plug	449-00015	1	449-00599	1
28	Plug, SAE-4, 1/4 BSPP	488-35061	2	447-01004	2
29	O-ring, 90 S-1 ARP 904	691-00904	2	-	-
30	Orifice, .032", 0.81 mm	035-40489	1	035-40489	1
31	O-Ring, 70 S-1 ARP 008	671-00008	1	671-00008	1

TORQUE LIMITER OVERRIDE

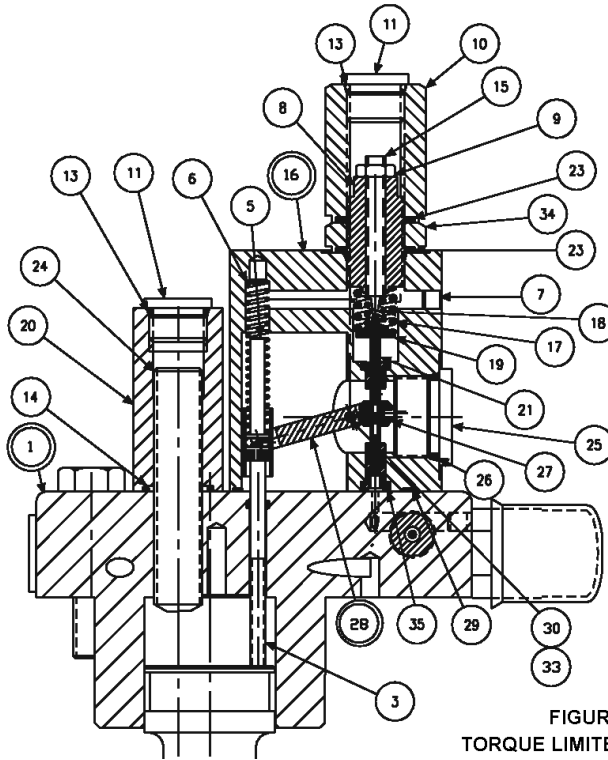

FIGURE 29
TORQUE LIMITER OVERRIDE

PARTS LIST FOR FIGURE 29

torque limiter override
P07 code J, S22-16207
P07 code K, S22-16209
P110 code J, S22-16208
P110 code K, S22-16210

ITEM	DESCRIPTION	P07	P110	QTY.	
		PART NO.	PART NO.	**J	**K
1	Cap (Figure 28)	S22-16049	S22-16050	1	1
3	Screw	032-91461	032-91461	1	1
5	Clevis pin	321-40000	321-40000	1	1
6	Spring, Compression	032-92100	032-92100	1	1
7	Plug, Avseal	447-00026	447-00026	1	1
8	Screw	032-91445	032-91445	1	1
9	Nut, Hex Jam 1/4-20 UNC	340-00038	340-00038	1	1
10	Hex Nut, 3/4-16 UNF	032-91449	032-91449	1	1
11	Plug, SAE-8	488-35018	488-35018	2	2
13	O-Ring, 90 S-1 ARP 908	691-00908	691-00908	2	2
14	O-ring, 70 S-1 ARP115	671-00115	671-00115	1	1
15	Screw, Primary Adjustment	032-91446	032-91446	1	1
16	Body assembly	S22-15396	S22-15396	1	1
17	Outer Spring – J Version	032-91440	032-91440	1	—
	Outer Spring – K Version	032-91440	032-91440	—	1
18	Inner Spring – J Version	032-92240	032-92240	1	—
	Inner Spring – K Version	032-91441	032-91441	—	1
19	Spring Retainer	032-91819	032-91819	1	1
20	Nut, M16 hex	032-91822	032-91822	1	1
21	Spool	032-91438	032-91438	1	1
23	O-ring, 70 S-1 ARP 118	671-00118	671-00118	2	2
24	Socket Setscrew, M16	311-50001	311-50001	1	1
25	Plug, SAE-12	488-35014	488-35014	1	1
26	O-Ring, 90 S-1 ARP 912	691-00912	691-00912	1	1
27	Sleeve	032-91437	032-91437	1	1
28	Arm assembly	S22-15520	S22-15520	1	1
29	O-Ring, 70 S-1 ARP 035	671-00035	671-00035	1	1
30	Dowel Pin	324-20824	324-20824	1	1
33	Screw, SHC 10-32 x 1/4	312-09041	312-09041	2	2
34	Nut	032-91645	032-91645	1	1
35	O-Ring, 70 S-1 ARP 010	671-00010	671-00010	1	1

TORQUE LIMITER OVERRIDE

Disassembly

1. See figure 29. Remove 2 screws holding torque limiter body (16) to cap assembly (1).
2. Remove all parts from torque limiter body (16) except pin (30) and arm assembly (28). It is not necessary to remove these parts unless broken or worn. Examine parts for wear or damage.
3. Remove screw (3). Examine head for excessive wear, and body for smooth sealing surface with O-ring.
4. See figure 28. Remove maximum volume stop assembly (items 11, 13, 14, 20, 24).
5. Remove cap assembly (1).
6. Remove plug (15) and attached parts. Remove spring (11) and spool (18).
7. Remove adjusting plug (2) and attached parts. Remove seal piston (5). Note: a 10-24 screw may be attached to assist in pulling the piston. Remove spring (7) and cone (8).
8. Do not remove sleeve in body (1). Sleeve is pressed into cap and finished to size. If sleeve, snout or cap is worn, replace the cap-sleeve assembly (1).
9. Examine seat (10) for wear. Do not remove unless damaged.

Assembly

See page 26 for tightening torque on plugs

1. See figure 28. Install Avseal plugs (9), plug (19), .032", 0,81 mm orifice (30).
2. Press seat (10) into bore squarely against shoulder in bore.
3. Install spool (18) into bore as shown. Install spring (11) over end of spool. Install O-ring (6) on seal piston (16). Lubricate and install into plug (15). Install O-rings (13) and (14) on plug (15) Install plug (15) into cap. Install screw (3), nut (4) and cover (17).
4. Install O-ring (6) on seal piston (5).
5. Lubricate O-ring and install cone (8), spring (7) and seal piston into bore in cap (1), being careful that cone enters seat (10). Install adjustment plug (2), screw (25), nut (4), and acorn nut (26).
6. Install plugs (12), (21) and (28) and torque.
7. Carefully install O-ring (31) into the cap.
8. Note proper location for cap (pg. 24). Install O-rings on interface between cap and pump control pad. Install cap assembly on pump, guiding the control piston into the bore. Torque two mounting screws to 75 lb.*ft., 102 Nm.
9. Install maximum stop screw (24), nut (20), O-ring (14) and plug (11) with O-ring (13).
10. See figure 29. Apply thread locking compound on threads of screw (3), lubricate the shank, thread through the cap into the control piston, and torque to 5 lb.*ft., 6,78 Nm.
11. Measure height from control cap to top of screw. With control piston at zero displacement, dimension must be .74 +/- .03 in., 18,8 +/- 0,76 mm.
12. Press dowel (30) into body (16), through the link assembly (28), to 1/4", 6,35 mm below surface. Apply hydraulic sealant to threads of screws (33) and install over dowel (30).
13. While sleeve (27) is engaged into dowel on link (28), slide spool (21) into bore of body (16), and through sleeve (27). Spool (21) must move freely and easily at all positions of the link (28).
14. Assemble remaining parts per drawing. Torque plug (11).
15. While spring retainer is engaging clevis pin (5) under dowel of link (28), slide the other opening of spring retainer over the top of the screw (3). Attach body assembly (16) to cap (1) and torque assembly screws to 75 lb.*ft., 102 Nm.
16. Install tubing assembly (Figure 24, 25).

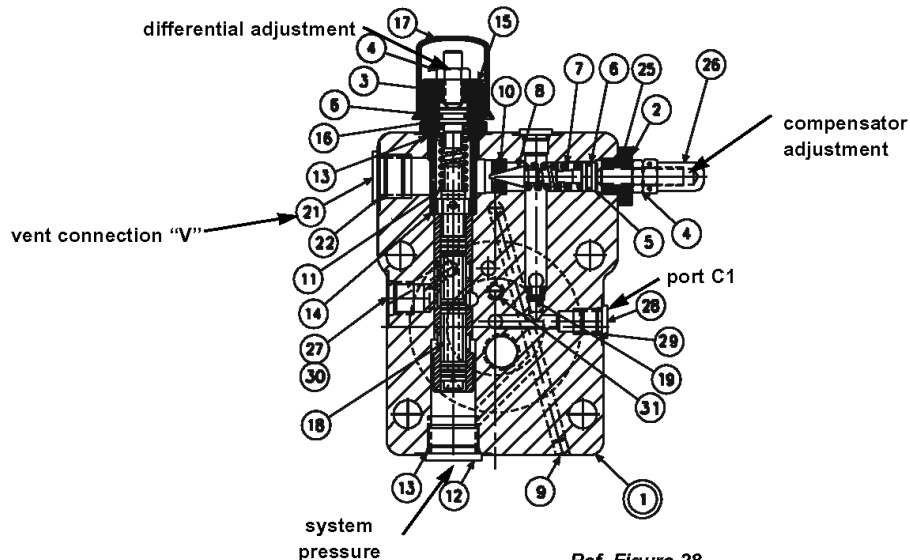

Ref. Figure 28
Torque limiter override cap

TEST PROCEDURE

Test Conditions: (If using service facility test stand)

Fluid: Mobil 4259 DE (ISO V6-32 or equivalent)

RPM: 1450 or 1750 \pm 50 RPM

Inlet Temperature: 120° F \pm 10° F, 49° C \pm 4° C

Inlet Condition: Atmospheric to + 5 psi, 0,345 bar

Case Pressure: 25 psi \pm 5 psi, 1,72 bar \pm 0,345 bar

Mount pump on test stand, or customer system. System line must have a relief valve. Connect system lines and case drain line. Fill pump case with clean oil. If pump is mounted vertically with the shaft up, vent the case by removing the plug from port "DG" to purge trapped air. To check for external leaks, install a check or relief valve in the case drain line to build 25 psi, 1,72 bar case pressure. Dry all oil from exterior of pump. If leaks are detected at any time, they shall be repaired before proceeding.

Adjust maximum volume stop to full displacement by backing off screw or handwheel CCW until there is no contact with control piston.

ROTARY SERVO TEST

The rotary servo mounts on the minimum displacement side of the pump. It utilizes a rotating shaft containing a cam to position a pin, and a sleeve positioned by a feedback link to the control cylinder. The sleeve/pin combination meters pilot flow to position a 4-way valve. This valve is ported to both ends of the control cylinder. The 4-way spool directs oil to/from the control cylinder such that it moves in a direction to maintain the metered position between the sleeve and spool. The pump displacement is thus established by the position of the shaft.

A compensator or torque limiter override may be installed on the on-stroke side of the control piston. When the set pressure or torque is reached, system pressure is directed into the piston to reduce displacement, overriding the servo commanded position.

Before testing the rotary servo, disable the compensator or torque limiter override, if applicable, by turning the compensator differential adjustment fully in. **CAUTION:** System must contain a relief valve to limit system pressure. System relief valve should be set to minimum pressure.

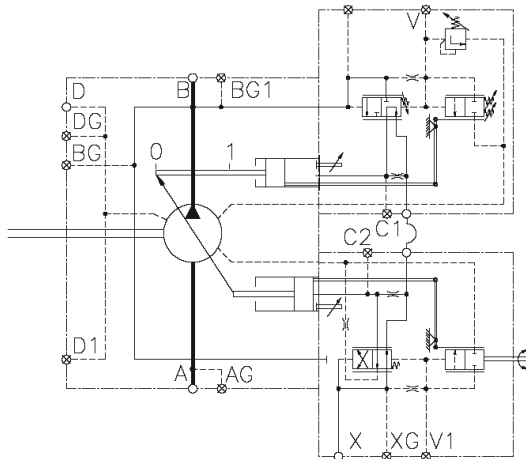

**HYDRAULIC CIRCUIT
ROTARY SERVO TORQUE
LIMITER OVERRIDE**

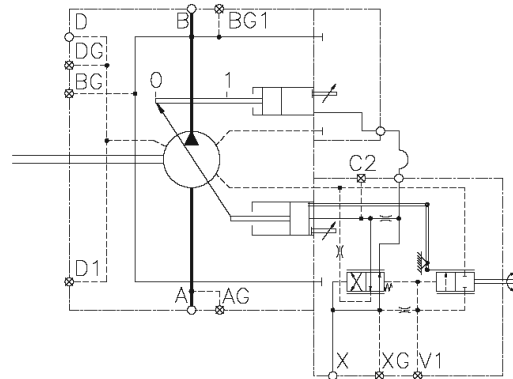

**HYDRAULIC CIRCUIT
ROTARY SERVO**

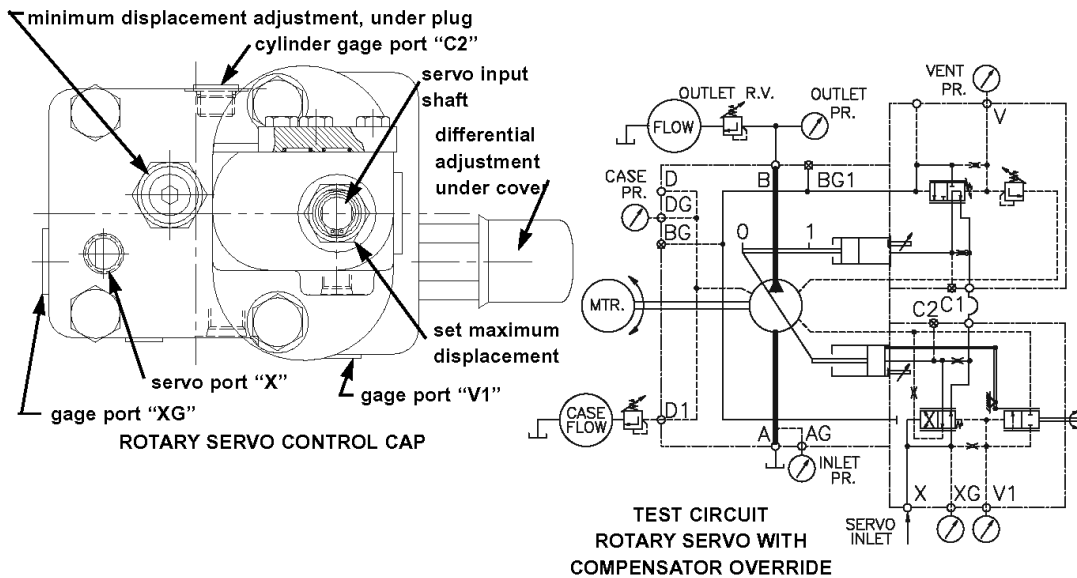

ROTARY SERVO TEST (continued)

Plumb servo supply (5 gpm, 19 lpm minimum at 1500 psi, 103 bar maximum) to control port "X".

Thread minimum displacement adjustment so that pump is on stroke.

Install gages on servo pressure gage port XG and on gage port V1, capable of measuring pressure difference to 10 psi, 0.69 bar. Gages must be adequate for servo pressure.

Turn servo differential adjustment screw in till solid, then seven turns out.

Start pump. Adjust rotary servo shaft till pump is at some displacement between zero and full. Adjust differential pressure by adjusting the differential screw until the difference in pressure readings between port XG and V1 is 250 +/-10 psi, 17.2 +/- 0.7 bar. Install cover over differential adjustment. Remove gages and plug gage ports.

With rotary servo shaft rotated fully clockwise, adjust maximum volume adjustment on servo until outlet flow is at the full displacement position. Lock in place.



Fully rotate servo shaft counter-clockwise. Pump flow should go towards zero displacement. Back out minimum volume stop until pump is at zero displacement. Lock in place.

Rotate shaft clockwise and counterclockwise at various outlet pressures. Pump displacement should follow shaft rotation between full and zero displacement smoothly and proportionally. Full to zero or zero to full displacement should be achieved in no more than .3 second.

Proceed to **COMPENSATOR TEST** (pg. 66), **TORQUE LIMITER TEST** (pg. 70), or **FINAL PUMP TEST** (pg. 75), as applicable.

TEST PROCEDURE

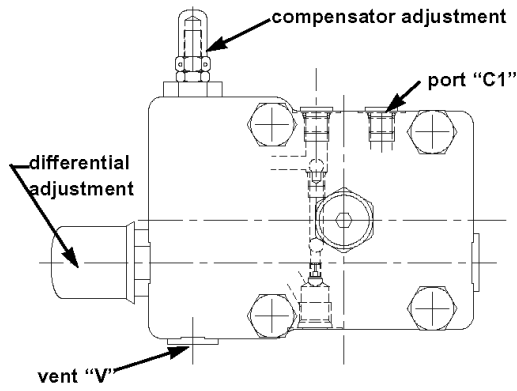

COMPENSATOR OVERRIDE CAP

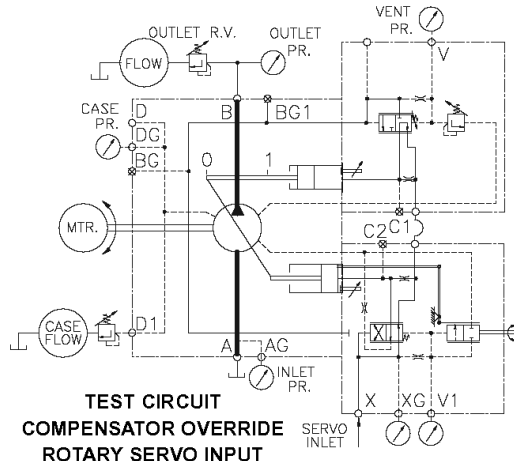

**TEST CIRCUIT
COMPENSATOR OVERRIDE
ROTARY SERVO INPUT**

COMPENSATOR TEST

Outlet relief valve should be set to minimum pressure.

If the pump contains a servo, hydraulic or electrohydraulic stroker control, test that control first, (pg. 64, 68 or 69) then set the control to give full displacement on the pump.

Install gages on outlet pressure and "V" capable of measuring pressure difference to 10 psi, 0,69 bar. Gages must be adequate for outlet pressure.

If testing pump with load sensing compensator or torque limiter control, the test stand must include a gage on the line from "LS" capable of measuring pressure difference to 10 psi, 0,69 bar and the other components shown in the load sensing test circuit. Open speed control valve fully, and close load valve to first test the compensator function.

Turn compensator adjustment screw CCW until there is no contact with spring, then adjust 1/2 turn CW after contact is made with spring.

Turn differential adjustment screw out till there is no contact with spring, then in 1-1/2 turns. (Approximately one nut width exposure of screw thread)

Start prime mover. Observe for correct rotation. Pump should be at full displacement at minimum pressure.

Adjust outlet relief valve until compensator destrokes pump to zero displacement. Adjust differential pressure across ports XG and V1 to 250+- 10 psi, 17,2 +- 0,7 bar. Compensator pressure should be approximately 1000 psi, 69 bar with the 1/2 turn pre-adjustment. Note: With servo type controls, minimum compensator pressure will be higher, depending on the servo supply pressure. See chart below.

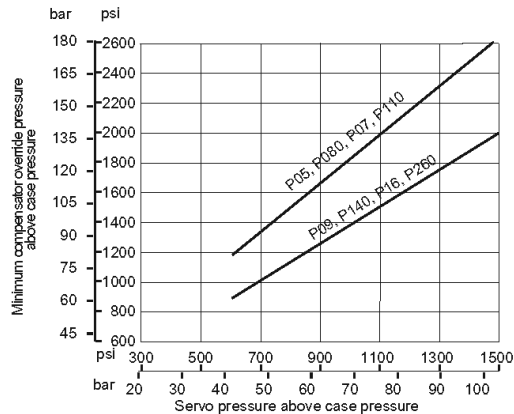

TEST PROCEDURE

Raise compensator from minimum to maximum outlet pressure. At each condition, increase the outlet pressure until the pump fully de-strokes. At no time should the outlet pressure vary over 150 psi, 10,3 bar from the compensator setting. The control should be steady and stable at all conditions.

Calculate compensator leakage by subtracting leakage flow at full flow from leakage flow fully compensated.
Compensator leakage: 5 gpm, 18.9 lpm. maximum

Reduce outlet pressure to 150 psi, 10,3 bar below the compensator setting. Pump should return to full displacement. Repeat two or more times. Compensator settings should be repeatable. Proceed to **FINAL PUMP TEST (pg. 75)**, or **LOAD SENSING TEST (below)** if applicable.

LOAD SENSING TEST

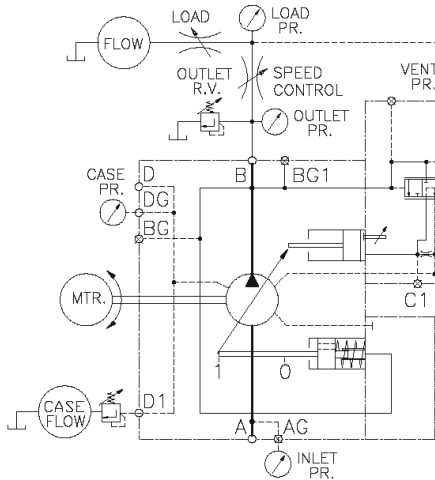

**TEST CIRCUIT
LOAD SENSING**

Caution: Load sensing control is limited to 5000 psi, 345 bar maximum pressure.

Pump should be connected to speed control valve, load sensing line and load valve as shown.

Close the speed control valve. Check the pressure difference from outlet pressure to load pressure. Using the differential adjustment, set this pressure difference to 450 psi \pm 25 psi, 31,0 \pm 1,72 bar or shop order requirement. Caution: Too low or too high a setting will cause the control to malfunction. Install cap on differential adjustment.

Fully open the speed control valve. Set the compensator to 3000 psi, 207 bar, and 5000 psi, 345 bar. (One turn of adjustment equals approximately 2000 psi, 138 bar.) At each condition, increase the outlet pressure by closing the load valve until the pump fully de-strokes. At no time should the outlet pressure vary more than 150 psi, 10,3 bar from the compensator setting. The control should be steady and stable at all conditions.

With pump at full flow and 5000 psi, 345 bar outlet pressure, close speed control valve till flow reduces slightly. Note flow. Open load valve slowly, to drop outlet pressure toward minimum. Flow shall remain constant within 2 gpm, 7,6 lpm at all pressures.

Adjust the speed control valve till flow is at a low value. Note flow. Raise and lower outlet pressure by closing and opening the load valve. Flow shall remain constant within 2 gpm, 7,6 lpm. Proceed to **FINAL PUMP TEST (pg. 75)**.

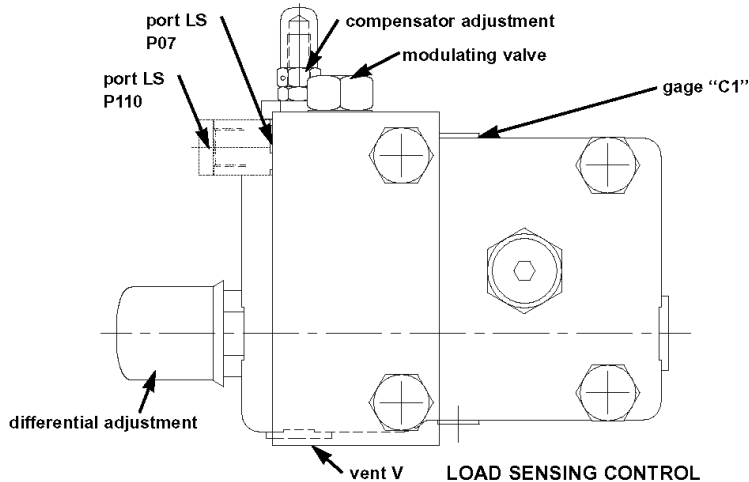

LOAD SENSING CONTROL

TEST PROCEDURE

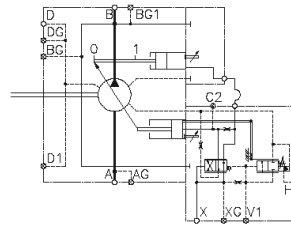
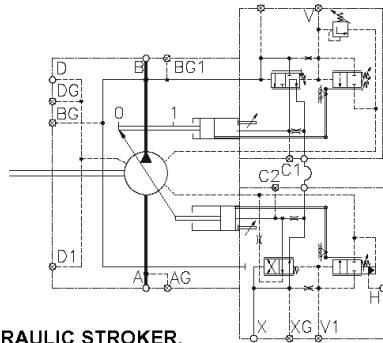
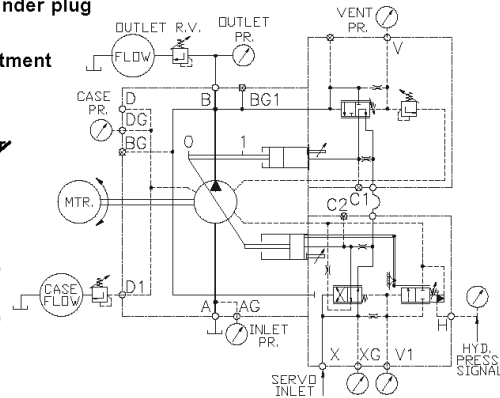
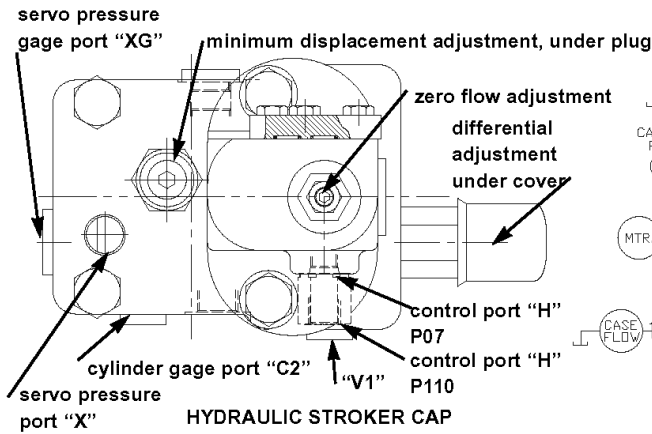

**HYDRAULIC STROKER,
 TORQUE LIMITER OVERRIDE**

HYDRAULIC STROKER

HYDRAULIC STROKER TEST

Before testing hydraulic stroker, disable the compensator or torque limiter override, if applicable, by turning the compensator differential adjustment fully in. (See compensator or torque limiter test). **CAUTION:** System must contain a relief valve to limit outlet pressure. Outlet relief valve should be set to minimum pressure.

Plumb servo supply (5 gpm, 19 lpm minimum at 1500 psi, 103 bar maximum) to control port "X". Plumb adjustable hydraulic pressure (50 to 350 psi, 3,45 to 24 bar) to control port "H".

Thread minimum displacement adjustment screw so that pump is on stroke.

Install gages on servo pressure gage port XG and on gage port V1, capable of measuring pressure difference to 10 psi, 0,69 bar. Gages must be adequate for servo pressure.

Turn hydraulic stroker differential adjustment screw in till solid, then out 7 turns.

Start pump. Apply hydraulic control signal to port "H" till pump is at some displacement between zero and full. Adjust differential pressure by adjusting the differential screw until the difference in pressure readings between port XG and V1 is 250 psi, 17,2 bar. Install cover over differential adjustment.

Set signal pressure to 50 psi, 3,45 bar. Back out zero volume stop and set zero flow adjustment until pump is at zero displacement. Lock both adjustments in place.

Slowly increase and decrease signal pressure between 0 and 275 psi, 19,0 bar several times at minimum and maximum operating outlet pressure. Pump displacement should follow control pressure smoothly and proportionally. Rapidly adjust signal pressure between 0 and 275 psi, 19,0 bar. Full to zero or zero to full displacement should be achieved in no more than 0,3 second.

Proceed to **COMPENSATOR TEST** (pg. 66), **TORQUE LIMITER TEST** (pg. 70), or **FINAL PUMP TEST** (pg. 75), as applicable.

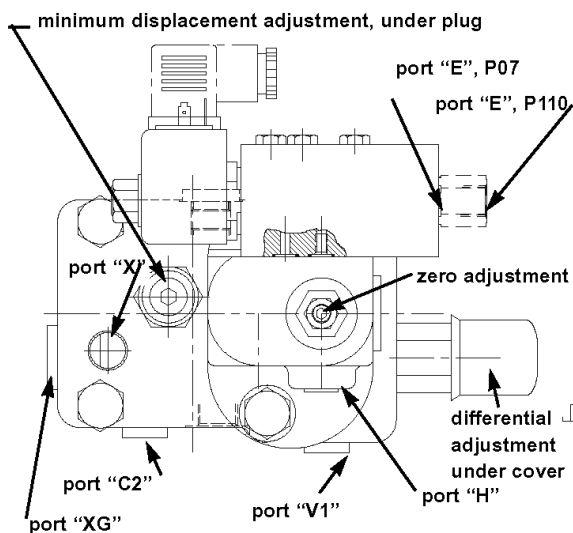

ELECTROHYDRAULIC STROKER CAP

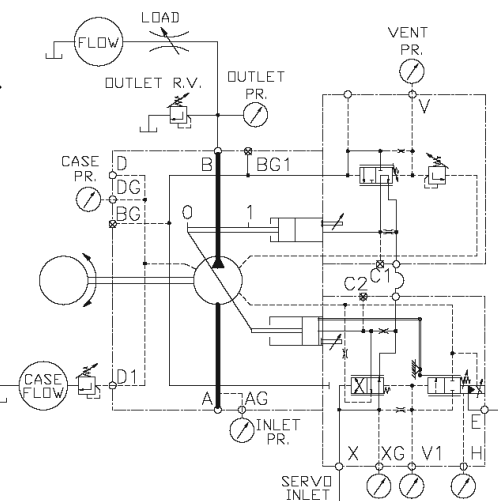

TEST CIRCUIT
ELECTROHYDRAULIC STROKER
COMPENSATOR OVERRIDE

ELECTROHYDRAULIC STROKER TEST

Before testing electrohydraulic stroker, disable the compensator or torque limiter override, if applicable, by turning the compensator differential adjustment fully in. (See compensator or torque limiter test) **CAUTION:** System must contain a relief valve to limit outlet pressure. Outlet relief valve should be set to minimum pressure.

Plumb servo supply (5 gpm, 19 lpm minimum at 1500 psi, 103 bar maximum) to control port "X", and to the electric stroker port, "E"

Install gages on servo pressure gage port XG and on gage port V1, capable of measuring pressure difference to 10 psi, 0,69 bar. Gages must be adequate for servo pressure.

Thread zero volume stop screw so that pump is on stroke.

Turn electrohydraulic stroker differential adjustment screw in till solid, then 7 turns out.

Start pump. Observe for correct rotation. Adjust current to proportional valve till pump is at some displacement between zero and full. Adjust differential pressure by adjusting the differential screw until the difference in pressure readings between port XG and V1 is 250 psi, 17,2 bar. Install cover over differential adjustment.

Adjust current to 170 mA. Back out zero volume stop and set zero flow adjustment until pump is at zero displacement. Lock both adjustments in place. If pump fails to respond, measure pressure at port "H", pressure to be 50 psi, 3,45 bar minimum, for 170 mA current with 24 V. coil. Remove gage after checking, to avoid unstable operation.

Increase current to 300 mA. Pump should go to full displacement. Set maximum volume screw on opposite control cap for full displacement.

Increase and decrease the amperage between 0 and 300 mA several times at minimum to maximum outlet pressure. Pump displacement should follow amperage smoothly and proportionally. Full to zero or zero to full displacement should be achieved in .3 second. Adjust amperage up to 225 mA from zero displacement, then adjust down from full displacement to 225 mA. The flows at the two 225 mA settings shall not vary more than 2 gpm, 7,6 lpm from each other.

Proceed to **COMPENSATOR TEST** (pg. 66), **TORQUE LIMITER TEST** (pg. 70), or **FINAL PUMP TEST** (pg. 75), as applicable.

TEST PROCEDURE

TORQUE LIMITER AND TORQUE LIMITER OVERRIDE TEST

The torque limiter design is a compensator with a means of varying pump displacement with pressure in this manner: The compensator vent port applies pressure to a pin. The pin moves against two independently adjustable springs. A sleeve, sliding over the pin, opens or closes the vent passage, to control the compensator pressure. The sleeve is connected through a linkage to the control piston. As pressure increases, the displacement must reduce, and vice versa, to provide approximate constant torque.

Install gages on outlet pressure and "V" capable of measuring pressure difference to 10 psi, 0,69 bar. Gages must be adequate for outlet pressure.

Turn compensator adjustment screw out to remove spring load, then 1/2 turn in.

Turn differential adjustment screw out till there is no contact with spring, then in 1-1/2 turns. (Approximately one nut width exposure of screw thread)

If the pump contains a servo, hydraulic or electrohydraulic stroker control, test that control first (pg. 64, 68 or 69) then set the control to give full displacement on the pump. **CAUTION:** System must contain a relief valve to limit outlet pressure. Outlet relief valve should be set at 500 psi, 34,5 bar.

To test and set compensator function, disable torque limiter in this manner: Back out high pressure flow adjustment screw (inner) to remove all load. Turn in high flow pressure adjustment screw (outer) to go solid. Caution! do not apply over 10 in.*lb, 1,2 Nm torque to avoid damage to internal parts!

Start prime mover with outlet relief set at 500 psi, 34,5 bar. Apply a load to the pump.

Pump should be at full displacement at 500 psi, 34,5 bar.

Increase outlet pressure until compensator de-strokes pump to zero displacement. Note minimum compensated pressure versus servo pressure in chart on page 66. Set compensator to minimum compensated pressure.

Adjust compensator differential spool pressure to 250 psi, 17,2 bar. This is accomplished by adjusting the differential screw until the difference in pressure readings between the outlet pressure and compensator vent "V" gages installed in the compensator cap is 250 psi, 17,2 bar. Install cover over differential adjustment.

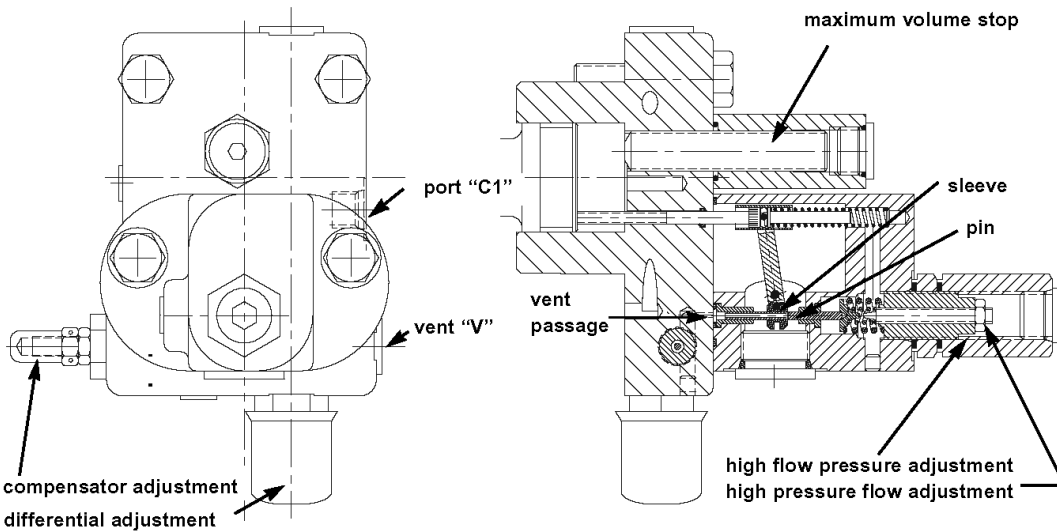
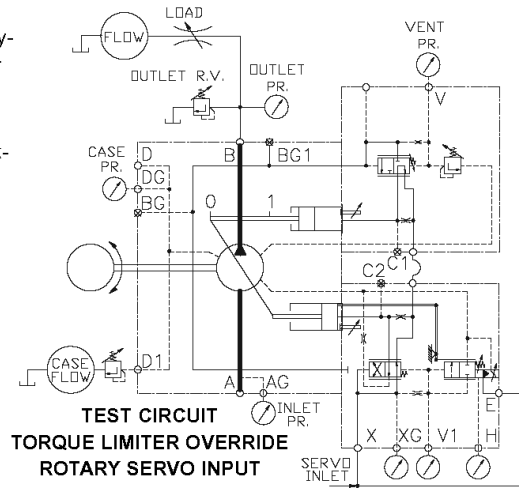

TORQUE LIMITER

TEST PROCEDURE

Set the compensator to 3000 psi, 207 bar, 6000 psi, 414 bar, and 7250 psi, 500 bar. (One turn approximately equals 2000 psi, 138 bar)

At each condition, increase the outlet pressure until the pump fully de-strokes. At no time should the outlet pressure vary more than 150 psi, 10,3 bar from the compensator setting. The control should be steady and stable at all conditions.

Reduce outlet pressure below the compensator setting. Pump should return to full displacement. Repeat two or more times. Compensator setting should be repeatable.

Set compensator adjustment to at least 500 psi, 34,5 bar above the maximum outlet pressure.

TORQUE LIMITER TEST AND ADJUSTMENT

Set the torque limiter by using the formula:

$$HP = P \cdot Q / (\text{Eff} \cdot 1714), \text{ or } P = HP (\text{Eff} \cdot 1714) / Q, \text{ or } Q = HP (\text{Eff} \cdot 1714) / P$$

where P = Pressure in psi

Q = flow in GPM

Eff. = overall efficiency

$$\text{or } kW = P \cdot Q / (\text{Eff} \cdot 600), \text{ or } P = kW (\text{Eff} \cdot 600) / Q, \text{ or } Q = kW (\text{Eff} \cdot 600) / P$$

where P = pressure in Bar

Q = flow in lpm

Eff. = overall efficiency

calculate these two values:

- a. Outlet pressure at full pump flow.
- b. Pump flow at full outlet pressure.

1. Set outlet to pressure (a) calculated above. Back out high pressure flow adjusting screw (inner screw) to remove all load. Set the high flow pressure adjusting screw (outer) so that pump just commences to de-stroke.

2. Set the system to the required maximum outlet pressure. Set high pressure flow adjusting screw (inner) to obtain the calculated flow (b) at full outlet pressure.

Note: Electric motor current or engine load may be used instead of calculated flows to set power. In step 1, set the high flow adjustment to achieve the rated motor current or engine load. In step 2, set the high pressure adjustment to achieve the rated motor current or engine load.

Proceed to **FINAL PUMP TEST** (pg. 75)

TEST PROCEDURE

LOAD SENSING TORQUE LIMITER

Caution: Load sensing control is limited to 5000 psi, 345 bar maximum pressure.

Pump should be connected to speed control valve, load sensing line and load valve as shown.

Install gages on outlet pressure and "V" capable of measuring pressure difference to 10 psi, 0,69 bar. Gages must be adequate for outlet pressure.

Turn compensator adjustment screw out to remove spring load, then 1/2 turn in.

Turn differential adjustment screw out till there is no contact with spring, then in 1-1/2 turns. (Approximately one nut width exposure of screw thread)

To test and set compensator and load sensing function, disable torque limiter in this manner: Back out high pressure flow adjustment screw (inner) to remove all load. Turn in high flow pressure adjustment screw (outer) to go solid. Caution! do not apply over 10 in.·lb, 1,2 Nm torque to avoid damage to internal parts!

Start prime mover with outlet relief set at 500 psi, 34,5 bar. Apply a load to the pump.

Pump should be at full displacement at 500 psi, 34,5 bar.

Increase outlet pressure until compensator de-strokes pump to zero displacement. Note minimum compensated pressure versus servo pressure in chart on page 58. Set compensator to minimum compensated pressure.

Adjust compensator differential spool pressure to 250 psi, 17,2 bar. This is accomplished by adjusting the differential screw until the difference in pressure readings between the outlet pressure and compensator vent "V" gages installed in the compensator cap is 250 psi, 17,2 bar. Install cover over differential adjustment.

Close the speed control valve. Check the pressure difference from outlet pressure to load pressure. Using the differential adjustment, set this pressure difference to 450 psi \pm 25 psi, 31,0 \pm 1,72 bar or shop order requirement. Caution: Too low or too high a setting will cause the control to malfunction. Install cap on differential adjustment.

Fully open the speed control valve. Set the compensator to 3000 psi, 207 bar, and 5000 psi, 345 bar. (One turn of adjustment equals approximately 2000 psi, 138 bar.) At each condition, increase the outlet pressure by closing the load valve until the pump fully de-strokes. At no time should the outlet pressure vary more than 150 psi, 10,3 bar from the compensator setting. The control should be steady and stable at all conditions.

With pump at full flow and 5000 psi, 345 bar outlet pressure, close speed control valve till flow reduces slightly. Note flow.

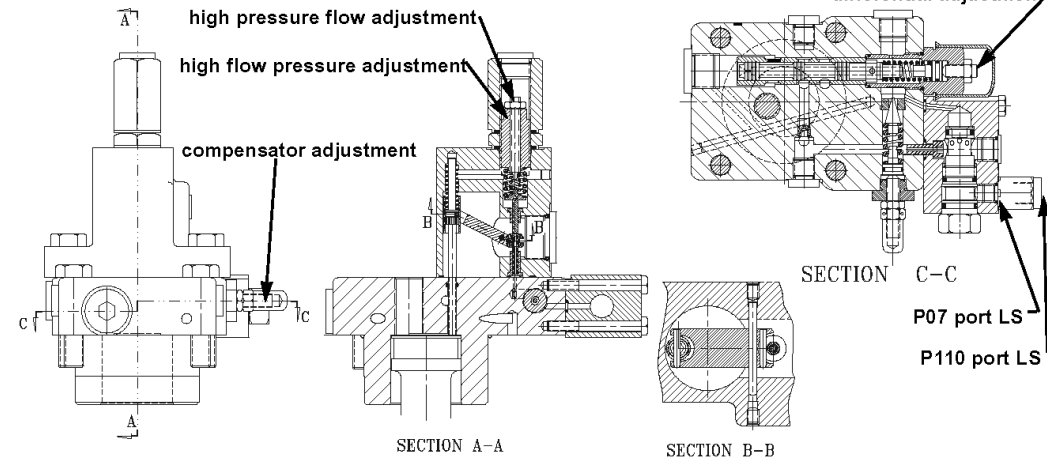
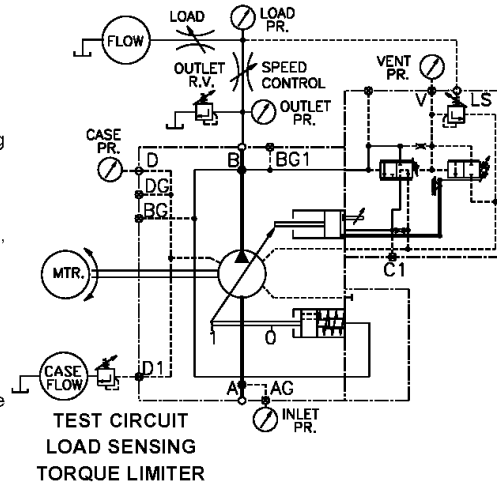

TEST PROCEDURE

Open load valve slowly, to drop outlet pressure toward minimum. Flow shall remain constant within 2 gpm, 7,6 lpm at all pressures.

Adjust the speed control valve till flow is at a low value. Note flow. Raise and lower outlet pressure by closing and opening the load valve. Flow shall remain constant within 2 gpm, 7,6 lpm.

Fully open the speed control valve.

Set the torque limiter by using the formula:

$$HP = P \cdot Q / (\text{Eff.} \cdot 1714), \text{ or } P = HP(\text{Eff.} \cdot 1714) / Q, \text{ or } Q = HP(\text{Eff.} \cdot 1714) / P$$

where P = Pressure in psi

Q = flow in GPM

Eff. = overall efficiency

$$\text{or } kW = P \cdot Q / (\text{Eff.} \cdot 600), \text{ or } P = kW(\text{Eff.} \cdot 600) / Q, \text{ or } Q = kW(\text{Eff.} \cdot 600) / P$$

where P = pressure in Bar

Q = flow in lpm

Eff. = overall efficiency

calculate these two values:

- a. Outlet pressure at full pump flow.
- b. Pump flow at full outlet pressure.

1. Set outlet to pressure (a) calculated above. Back out high pressure flow adjusting screw (inner screw) to remove all load. Set the high flow pressure adjusting screw (outer) so that pump just commences to de-stroke.

2. Set the system to the required maximum outlet pressure. Set high pressure flow adjusting screw (inner) to obtain the calculated flow (b) at full outlet pressure.

Note: Electric motor current or engine load may be used instead of calculated flows to set power. In step 1, set the high flow adjustment to achieve the rated motor current or engine load. In step 2, set the high pressure adjustment to achieve the rated motor current or engine load.

Proceed to **FINAL PUMP TEST (pg. 75)**

PQ CONTROL
IN PROCESS OF DEVELOPMENT

TEST PROCEDURE

FINAL PUMP TEST

Operate the pump with the following outlet pressures for the times indicated.

3000 psi \pm 100 psi, 207 bar \pm 6,9 bar	2 minutes minimum
5000 psi \pm 100 psi, 345 bar \pm 6,9 bar	1 minute minimum
6000 psi \pm 100 psi, 414 bar \pm 6,9 bar	1 minute minimum

While breaking in, destroke the pump several times at each pressure setting, by either reducing compensator setting, servo/stroker command, or Q command to PQ control, as applicable.

PUMP SERIES	FULL DISPLACEMENT REQUIREMENTS AT 6000 PSI, 414 BAR			
	MINIMUM OUTPUT FLOW		MAX CASE DRAIN FLOW	
	GPM	LPM	GPM	LPM
P07/P110 @ 1750 RPM	47.0	178	3.0	11,4
P07/P110 @ 1450 RPM	41.3	156	3.0	11,4

Raise compensator setting from minimum to maximum outlet pressure. **Caution:** Load sensing control is limited to 5000 psi, 345 bar maximum pressure.

At each condition, increase the outlet pressure until the pump fully de-strokes. At no time should the outlet pressure vary over 150 psi, 10,3 bar from full to zero flow. The control should be steady and stable at all conditions.

Reduce outlet pressure to 150 psi, 10,3 bar below the compensator setting. Pump should return to full displacement. Repeat two or more times. Compensator settings should be repeatable. Set compensator at 1000 psi \pm 100 psi, 69 bar \pm 6,9 bar standard, or desired value.

Check for leaks. NO external leaks are permitted. The shaft seal can be dry or damp. (Damp: A very small amount of oil at the seal and shaft joint, but NOT running onto the seal face).

ASSEMBLY TOOLS

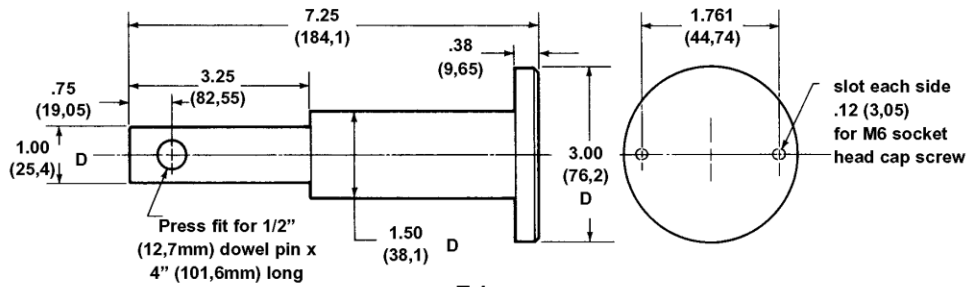

T-1
(Lifting tool)
barrel & inner race assembly

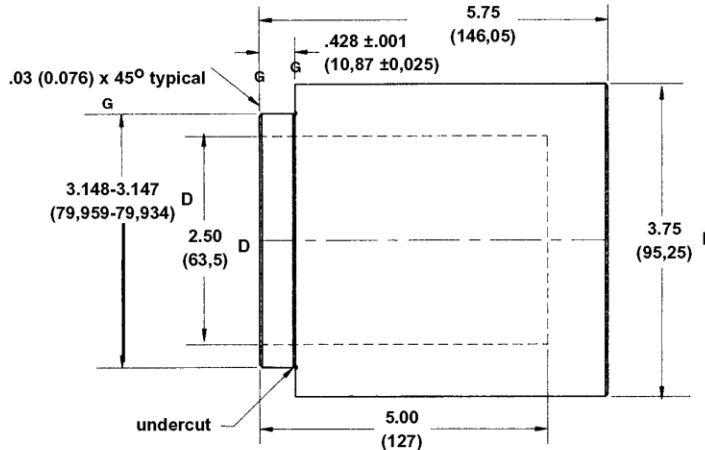

T-2
(installation tool)
retainer & shaft bearing in cradle

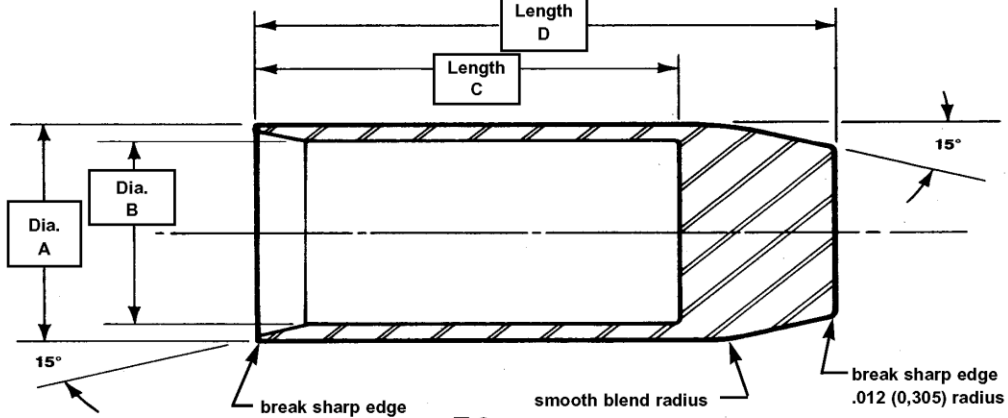

T-3
(installation tool)
shaft seal over shaft

Shaft	A		B		C		D	
	in.	mm	in.	mm	in.	mm	in.	mm
P07 keyed	1.878/1/880	47,70/47,75	1.755/1.760	44,58/44,70	3.00	76,2	4.50	114,3
P07 splined	1.878/1/880	47,70/47,75	1.725/1.730	43,82/43,94	3.00	76,2	4.50	114,3
P110 (all)	1.878/1/880	47,70/47,75	1.580/1.582	40,13/40,18	3.25	82,5	4.75	120,6

INSTALLATION PROCEDURES, AND TECHNICAL SPECIFICATIONS AND LIMITS

GENERAL

The DENISON HYDRAULICS P07/P110 Series is a variable displacement open circuit axial piston pump with advance pumping and control concepts.

MOUNTING

This pump is designed to operate in any position. The pump shaft must be in alignment with the shaft of the prime mover and should be checked with a dial indicator. The mounting pad or adapter into which the pump pilots must be concentric with the pump shaft to prevent bearing failure. This concentricity is particularly important if the shaft is rigidly connected to the prime mover without a flexible coupling.

SHAFT INFORMATION

Splined: The shafts will accept a maximum misalignment of .006", 0.15 mm TIR. Angular misalignment at the male and female spline axis must be less than 0.001 in. per in. radius, 0.001 mm per mm. The coupling interface must be lubricated. DENISON HYDRAULICS recommends lithium molydisulfide or similar grease. The female coupling should be hardened to 27-34 Rc. and must conform to SAE J498B (1971) class 1 flat root side fit. (P07), ISO 4156 fillet root side fit module 1.00 or DIN 5480 (9H) flat root side fit module 2.00 as applicable. (P110)

Keyed: High strength heat treated keys must be used. Replacement keys must be hardened to 27-34 Rc. The key corners must be chamfered .030"-.040", 0.75-1.00 mm at 45° to clear radii that exist in the keyway.

PORTING INFORMATION

See port identification section for port locations and sizes.

The maximum case pressure is 25 psi, 1.7 bar continuous, 50 psi, 3.4 bar intermittent. Case pressures must never exceed inlet pressure by more than 25 psi, 1.7 bar. When connecting case drain line make certain that drain plumbing passes above highest point of the pump before returning to the reservoir, if not, install a 5 psi, 0.3 bar case pressure check valve to be certain the case is filled with oil at all times.

The case drain line must be of sufficient size to prevent back pressure in excess of 25 psi, 1.7 bar and returned to the reservoir below the surface of the oil as far from the supply suction as possible. All fluid lines, whether pipe, tubing, or hose must be of adequate size and strength to assure free flow through the pump. An undersize inlet line will prevent the pump from reaching full speed and torque. An undersized outlet line will create back pressure and cause improper operation. Flexible hose lines are recommended. If rigid piping is used, the workmanship must be accurate to eliminate strain on the pump port block or to the fluid connections. Sharp bends in the lines must be eliminated wherever possible. All system piping must be cleaned with solvent or equivalent before installing pump. Make sure the entire hydraulic system is free of dirt, lint, scale, or other foreign material.

CAUTION: Do not use galvanized pipe. Galvanized coating can flake off with continued use.

INLET CONDITIONS AT SEA LEVEL, FULL DISPLACEMENT

SPEED	GAGE PRESSURE				ABS. PRESS.	
	psig	bar	in. hg	mm hg	psi	bar
1200	-3	-0.2	-6.1	-155	11.7	0.8
1800	-3	-0.2	-6.1	-155	11.7	0.8
2100	-3	-0.2	-6.1	-155	11.7	0.8
2450	0	0	0	0	0	1.01
3000	6.3	0.44	12.8	326	22.1	1.52

NOTE: Inlet conditions apply for petroleum base fluids. Contact DENISON HYDRAULICS for inlet conditions with other fluids.

RECOMMENDED FLUIDS

See DENISON HYDRAULICS bulletin **SPO-AM305** for more information

MAINTENANCE

This pump is self-lubricating and preventative maintenance is limited to keeping system fluid clean by changing filters frequently. Keep all fittings and screws tight. Do not operate at pressures and speeds in excess of the recommended limit. If the pump does not operate properly, check the troubleshooting chart before attempting to overhaul the unit. Overhauling is relatively simple and may be accomplished by referring to the disassembly, rework limits of wear parts and assembly procedures.

FLUID CLEANLINESS

Fluid must be cleaned before adding to the system, and continuously during operation by filters that maintain a cleanliness level of NAS 1638 Class 8. This approximately corresponds to ISO 17/14.

INSTALLATION PROCEDURES, AND TECHNICAL SPECIFICATIONS AND LIMITS

GENERAL

The DENISON HYDRAULICS P07/P110 Series is a variable displacement open circuit axial piston pump with advance pumping and control concepts.

MOUNTING

This pump is designed to operate in any position. The pump shaft must be in alignment with the shaft of the prime mover and should be checked with a dial indicator. The mounting pad or adapter into which the pump pilots must be concentric with the pump shaft to prevent bearing failure. This concentricity is particularly important if the shaft is rigidly connected to the prime mover without a flexible coupling.

SHAFT INFORMATION

Splined: The shafts will accept a maximum misalignment of .006", 0.15 mm TIR. Angular misalignment at the male and female spline axis must be less than 0.001 in. per in. radius, 0.001 mm per mm. The coupling interface must be lubricated. DENISON HYDRAULICS recommends lithium molydisulfide or similar grease. The female coupling should be hardened to 27-34 Rc. and must conform to SAE J498B (1971) class 1 flat root side fit. (P07), ISO 4156 fillet root side fit module 1.00 or DIN 5480 (9H) flat root side fit module 2.00 as applicable. (P110)

Keyed: High strength heat treated keys must be used. Replacement keys must be hardened to 27-34 Rc. The key corners must be chamfered .030"-.040", 0.75-1.00 mm at 45° to clear radii that exist in the keyway.

PORTING INFORMATION

See port identification section for port locations and sizes.

The maximum case pressure is 25 psi, 1.7 bar continuous, 50 psi, 3.4 bar intermittent. Case pressures must never exceed inlet pressure by more than 25 psi, 1.7 bar. When connecting case drain line make certain that drain plumbing passes above highest point of the pump before returning to the reservoir, if not, install a 5 psi, 0.3 bar case pressure check valve to be certain the case is filled with oil at all times.

The case drain line must be of sufficient size to prevent back pressure in excess of 25 psi, 1.7 bar and returned to the reservoir below the surface of the oil as far from the supply suction as possible. All fluid lines, whether pipe, tubing, or hose must be of adequate size and strength to assure free flow through the pump. An undersize inlet line will prevent the pump from reaching full speed and torque. An undersized outlet line will create back pressure and cause improper operation. Flexible hose lines are recommended. If rigid piping is used, the workmanship must be accurate to eliminate strain on the pump port block or to the fluid connections. Sharp bends in the lines must be eliminated wherever possible. All system piping must be cleaned with solvent or equivalent before installing pump. Make sure the entire hydraulic system is free of dirt, lint, scale, or other foreign material.

CAUTION: Do not use galvanized pipe. Galvanized coating can flake off with continued use.

INLET CONDITIONS AT SEA LEVEL, FULL DISPLACEMENT

SPEED	GAGE PRESSURE				ABS. PRESS.	
	psig	bar	in. hg	mm hg	psi	bar
1200	-3	-0.2	-6.1	-155	11.7	0.8
1800	-3	-0.2	-6.1	-155	11.7	0.8
2100	-3	-0.2	-6.1	-155	11.7	0.8
2450	0	0	0	0	0	1.01
3000	6.3	0.44	12.8	326	22.1	1.52

NOTE: Inlet conditions apply for petroleum base fluids. Contact DENISON HYDRAULICS for inlet conditions with other fluids.

RECOMMENDED FLUIDS

See DENISON HYDRAULICS bulletin SPO-AM305 for more information

MAINTENANCE

This pump is self-lubricating and preventative maintenance is limited to keeping system fluid clean by changing filters frequently. Keep all fittings and screws tight. Do not operate at pressures and speeds in excess of the recommended limit. If the pump does not operate properly, check the troubleshooting chart before attempting to overhaul the unit. Overhauling is relatively simple and may be accomplished by referring to the disassembly, rework limits of wear parts and assembly procedures.

FLUID CLEANLINESS

Fluid must be cleaned before adding to the system, and continuously during operation by filters that maintain a cleanliness level of NAS 1638 Class 8. This approximately corresponds to ISO 17/14.

PUMP ORDERING CODE

Ordering Code P07/110 - 02R1C - C10 - 00 - M2

Pump service _____

Displacement, max* -----

07 - 6.7 in³/rev.
110 - 109,8 cm³/rev.

Shaft _____

02-Keyed -SAE 44-1 (D) (P07)
- ISO 3019/2 G40N (P110)
03-Splined -SAE 44-4 (D) (P07)
- ISO 3019/2 K40N (P110)
06-Keyed - DIN 6885 40mm (P110)
07-Splined DIN 5480 40mm (P110)

Shaft rotation -----

(viewed from shaft end)
R-CW (standard, high speed)
L-CCW (standard, high speed)

Fluid class _____

1-compatible with Buna N
4-compatible with EPR
5-compatible with Viton

Design letter -----

Primary controls _____

C-Pressure compensator
E-Electric stroker
H-Hydraulic stroker
J-Low torque limiter *1100-1850 lbs-in., 124-209Nm
K-High torque limiter *over 1850 lbs-in., 209 Nm
L-Load sensing
R-Rotary servo
V- Low torque limiter with Load sensing *1100-1850 lbs-in., 124-209Nm
W- High torque limiter with Load sensing *over 1850 lbs-in., 209 Nm
X- 24 VDC PQ high response (pending)

Omit-Standard model
M2- Special modification to standard units
NP- No paint

Modification
O No pump mounted
1- Auxiliary pump (only) with M- modification
(user must advise attitude of rear pump/s mounting. For ordering two standard or three or more units refer to ordering code for multiple units)

Rear drive mounting
(Appropriate coupling and seals are included)
O-None
M-Rear drive blanking plate
A-SAE 82-2 (A) flange, SAE 16-4 (A) shaft
G-SAE 82-2 (A) flange, SAE 22-4 (B) shaft
B-SAE 101-2/4 (B) flange, SAE 22-4 (B) shaft
Q-SAE 101-2/4 (B) flange, SAE 25-4 (BB) shaft
C-SAE 127-2/4 (C) flange, SAE 32-4 (C) shaft
N-SAE 127-2/4 (C) flange, SAE 38-4 (CC) shaft
D-SAE 152-4 (D) flange, SAE 44-4 (D&E) shaft
Z-ISO 3019/2 (100 B4HW) flange, K25N shaft
Y-ISO 3019/2 (125 B4HW) flange, K32N shaft
X-ISO 3019/2 (160 B4HW) flange, K40N shaft
T-ISO 3019/2, (180 B4HW) flange, K40N shaft
L-ISO 3019/2, (180 B4HW) flange, DIN 40-18 shaft

Secondary controls
O-None
P-*Pressure compensator override
J-*Torque limiter override (low) 1100-1850 in-lbs., 124-209 Nm
K-*Torque limiter override (high) over 1850 in-lbs., 209 Nm
(*E, H & R primary controls only)

Primary control options
1-Standard maximum volume screw, without indicator
2-Handwheel maximum volume control without indicator
(available on C, J, K, L, V & W primary controls only)
3-Maximum volume screw with cam position potentiometer
(pending)
4-Maximum volume screw with cam position LVDT
(pending)
5-Maximum volume screw with cam position indicator
6-Handwheel maximum volume control with cam position potentiometer (pending)
7-Handwheel maximum volume control with cam position LVDT
(pending)
8-Handwheel maximum control with cam position indicator
(available on C, J, K, L, V & W primary controls only)

Available control combinations
C10, C20, C50, C80
E10, E50, E1P, E5P,
E1J, E5J, E1K, E5K,
H10, H50, H1P, H5P,
H1J, H5J, H1K, H5K
R10, R50, R1P, R5P,
R1J, R5J, R1K, R5K
J10, J20, J50, J80
K10, K20, K50, K80
L10, L20, L50, L80
V10, V20, V50, V80
W10, W20, W50, W80

* Minimum torque values to maintain 5000 psi, 345 bar at 1800 rpm. Consult DENISON Hydraulics for minimums at lesser pressures and speeds.

SALES & SERVICE WORLDWIDE

International Distributors

In Europe:

Cyprus
Czech Republic
Eastern Europe
The Faroe Islands
Finland
Greece
Hungary
Iceland
Norway
Poland
Portugal
Roumania
Russia
Serbia Montenegro
Slovakia
Slovenia
Switzerland
Turkey

In Africa:

Algeria
Egypt
Ivory Coast
Morocco
Nigeria
South Africa
Togo
Tunisia

In Middle East:

Bahrain
Iran
Israel
Jordan
Lebanon
Pakistan
Qatar
Saudi Arabia
Syria
United Arab Emirates

In Far East:

Indonesia
Korea
Malaysia
New Zealand
Philippines
Thailand

Australia

DENISON HYDRAULICS Pty. Ltd.
41-43 St. Hillers Road
P.O. Box 192
Auburn, N.S.W. 2144
Australia
Tel. (612) 9646 5200
Fax (612) 9643 1305

Other sales offices:
Queensland
South Wantirna Victoria
Western Australia

Austria

DENISON HYDRAULIK GmbH
Zweig Niederlassung Linz
Haidbachstraße 69
A-4061 Pasching
Austria
Tel. (43) 7229 4887
Fax (43) 7229 63092

BeneLux

DENISON HYDRAULICS
BENELUX B. V.
Pascallestraat 100
3316 Dordrecht
Holland
Tel. (31) 786179 900
Fax (31) 786175 755

Canada

DENISON HYDRAULICS
CANADA Inc.
2320 Bristol Circle, Unit 1
Oakville, ON L6H 5S2
Canada
Tel. (905) 829 5800
Fax (905) 829 5805

Other sales offices:
Montreal, QC
Calgary, AB

Denmark

DENISON HYDRAULIK
DENMARK A/S
Industrikrogen 2
DK-2635 Ishøj
Denmark
Tel. (45) 4371 15 00
Fax (45) 4371 15 16

Finland

DENISON HYDRAULICS
P.O. Box 1096
Alhotie 24
FIN-04431 Järvenpää
Finland
Tel/Fax (358) 0 2710 588

France

DENISON HYDRAULICS
FRANCE SA
14, route du Bois Blanc
BP 539
18105 Vierzon
France
Tel. (33) 2 48 53 01 20
Fax (33) 2 48 75 02 91

Other sales offices:
Bordeaux
Lyon
Paris

Germany

DENISON HYDRAULIK GmbH
Herdenstrasse 26
D-40721 Hilden
Germany
Tel. (49) 2103 940-6
Fax (49) 2103 940-880

Other sales offices:
Dresden
Hanover
Stuttgart

Great Britain

DENISON HYDRAULICS U.K.
Ltd.
Kermore Road
Wakefield 41, Industrial Estate
Wakefield, WF20XE
West Yorkshire
England
Tel. (44) 19 24 826 021
Fax (44) 19 24 826 146

Other sales offices:
Burgess Hill

Hong Kong

DENISON HYDRAULICS Ltd.
Unit 2, 25/F Wharf Cable Tower
9 Hoi Shing Road
Tsuen Wan
N.T., Hong Kong
Tel. (852) 24988381
Fax (852) 24991522

Italy

DENISON HYDRAULICS S.r.l.
Viale Europa 68
20090 Cusago
Milano
Italy
Tel. (39) 2 90330 1
Fax (39) 2 90390 695

Japan

DENISON JAPAN Inc.
4-2-1 Tsujido-Shinmachi
Fujisawa 251,
Japan
Tel. (81) 466 35 3257
Fax (81) 466 35 2029

Other sales office:
Osaka

Mexico, Central America, South America and Caribbean Countries Contact

DENISON HYDRAULICS Inc.
6167 NW 181 Terrace Circle North
Miami, FL 33015
USA
Tel. (305) 362 2246
Fax (305) 362 6220

P.R. China

DENISON HYDRAULICS Ltd.
3F, No. 1, Mao Jia Zhai, Bai Lian Jing
Pudong New Area,
Shanghai 200126, China
Tel. (86) 21 5886 8991
Fax (86) 21 5886 1978

Singapore

DENISON HYDRAULICS S.E.A. Pte
Ltd.
No. 11 Lorong Tukang Dua
Singapore 2261
Tel. (65) 2687840
Fax (65) 2687847

Spain

DENISON HYDRAULICS, S.A.
Gornis, 1
08023 Barcelona
Spain
Tel. (34) 3418 46 87
Fax (34) 3211 65 07

Other sales offices:
San Sebastian

Sweden

DENISON HYDRAULICS
SVENSKA AB
Sporregatan 13
213 77 - Malmö
Sweden
Tel. (46) 40 21 04 40
Fax (46) 40 21 47 26

Other sales offices:
Spånga

Taiwan

DENISON HYDRAULICS Ltd.
6F-10, No. 79, Sec. 2, Roosevelt road,
Taipei, Taiwan, R.O.C.
Tel. (886) 2 3645101 / 3645102
Fax (886) 2 3639025

USA

DENISON HYDRAULICS Inc.
14249 Industrial Parkway
Marysville, OH 43040
USA
Tel. 937 644 3915
Fax 937 642 3738
For nearest Distributor:
Call toll free 1 800 551 5956
E-Mail address:
denison@denisonhydraulics.com
WWW address:
http://www.denisonhydraulics.com

Other sales offices:

Fulton, CA
Mulberry, FL
Moline, IL
Rock Island, IL
Kentwood, MI
Portland, OR
Canton, MS
Arlington, TX
Houston, TX

Other European, Middle East and African Countries Contact

DENISON HYDRAULICS
FRANCE SA
14, route du Bois Blanc
BP 539
18105 Vierzon Cedex
France
Tel. (33) 2 48 53 01 44
Fax (33) 2 48 53 01 46

Your local DENISON representative

DENISON Hydraulics



APPENDIX VII

**Safety Data Sheet
(SDS)
Hydraulic Fluid**

Skydrol® LD4 Fire Resistant Hydraulic Fluid

Version Revision Date: SDS Number: Date of last issue: 06/02/2015
2.2 08/09/2016 150000093409 Date of first issue: 10/24/2013
SDSUS / PRD / 0001

SECTION 1. IDENTIFICATION

Product name : Skydrol® LD4 Fire Resistant Hydraulic Fluid

Product code : P3410201

Manufacturer or supplier's details

Company name of supplier : Eastman Chemical Company

Address : 200 South Wilcox Drive
 Kingsport TN 37660-5280

Telephone : (423) 229-2000

Emergency telephone number : CHEMTREC: +1-800-424-9300, +1-703-527-3887 CCN7321
 For emergency transportation information, in the United States:
 call CHEMTREC at 800-424-9300 or call 423-229-2000.

Recommended use of the chemical and restrictions on use

Recommended use : Hydraulic fluids

Restrictions on use : None known.

SECTION 2. HAZARDS IDENTIFICATION**GHS Classification**

Skin irritation : Category 2

Carcinogenicity : Category 2

GHS label elements

Hazard pictograms :



Signal word : Warning

Hazard statements : H315 Causes skin irritation.
 H351 Suspected of causing cancer.

Precautionary statements : **Prevention:**
 P201 Obtain special instructions before use.
 P202 Do not handle until all safety precautions have been read
 and understood.
 P264 Wash skin thoroughly after handling.
 P280 Wear protective gloves/ protective clothing/ eye protection/
 face protection.

Skydrol® LD4 Fire Resistant Hydraulic Fluid

Version Revision Date: SDS Number: Date of last issue: 06/02/2015
 2.2 08/09/2016 15000093409 Date of first issue: 10/24/2013
 SDSUS / PRD / 0001

Response:

P302 + P352 IF ON SKIN: Wash with plenty of soap and water.
 P308 + P313 IF exposed or concerned: Get medical advice/
 attention.

P332 + P313 If skin irritation occurs: Get medical advice/
 attention.

P362 Take off contaminated clothing and wash before reuse.

Storage:

P405 Store locked up.

Disposal:

P501 Dispose of contents/ container to an approved waste disposal plant.

Other hazards

None known.

SECTION 3. COMPOSITION/INFORMATION ON INGREDIENTS**Components**

Chemical name	CAS-No.	Concentration (% w/w)
Tributyl phosphate	126-73-8	55 - 65
Dibutylphenylphosphate	2528-36-1	20 - 30
Butyl diphenyl phosphate	2752-95-6	5 - 10
7-Oxabicyclo[4.1.0]heptane-3-carboxylic acid, 2-ethylhexyl ester	62256-00-2	< 10
butylated hydroxytoluene	128-37-0	1

SECTION 4. FIRST AID MEASURES

- If inhaled : Move to fresh air.
 If breathing is difficult, give oxygen.
 Consult a physician if necessary.
- In case of skin contact : Wash off immediately with plenty of water for at least 15 minutes.
 Get medical attention if symptoms occur.
 Wash contaminated clothing before reuse.
- In case of eye contact : In case of contact, immediately flush eyes with plenty of water for at least 15 minutes.
 Get medical attention if symptoms occur.
- If swallowed : Call a physician or poison control centre immediately.
 Do not induce vomiting without medical advice.
 Rinse mouth.
 Never give anything by mouth to an unconscious person.
- Most important symptoms and effects, both acute and delayed : Causes skin irritation.
 Suspected of causing cancer.

Skydrol® LD4 Fire Resistant Hydraulic Fluid

Version Revision Date: SDS Number: Date of last issue: 06/02/2015
 2.2 08/09/2016 15000093409 Date of first issue: 10/24/2013
 SDSUS / PRD / 0001

Wash thoroughly after handling.
 Wash contaminated clothing before reuse.
 Drain or remove substance from equipment prior to break-in or maintenance.
 Handle in accordance with good industrial hygiene and safety practice.

Conditions for safe storage : Store locked up.
 Keep container tightly closed in a dry and well-ventilated place.
 Keep in a cool place away from oxidizing agents.

SECTION 8. EXPOSURE CONTROLS/PERSONAL PROTECTION**Components with workplace control parameters**

Components	CAS-No.	Value type (Form of exposure)	Control parameters / Permissible concentration	Basis
Tributyl phosphate	126-73-8	TWA (Inhalable fraction and vapor)	5 mg/m ³	ACGIH
		TWA	0.2 ppm 2.5 mg/m ³	NIOSH REL
		TWA	5 mg/m ³	OSHA Z-1
		TWA	0.2 ppm 2.5 mg/m ³	OSHA P0
Dibutylphenylphosphate	2528-36-1	TWA	0.3 ppm	ACGIH
butylated hydroxytoluene	128-37-0	TWA (Inhalable fraction and vapor)	2 mg/m ³	ACGIH
		TWA	10 mg/m ³	NIOSH REL
		TWA	10 mg/m ³	OSHA P0

Hazardous components without workplace control parameters

Components	CAS-No.
7-Oxabicyclo[4.1.0]heptane-3-carboxylic acid, 2-ethylhexyl ester	62256-00-2

Engineering measures : Good general ventilation (typically 10 air changes per hour) should be used. Ventilation rates should be matched to conditions. If applicable, use process enclosures, local exhaust ventilation, or other engineering controls to maintain airborne levels below recommended exposure limits. If exposure limits have not been established, maintain airborne levels to an acceptable level.

Personal protective equipment

Respiratory protection : Use a properly fitted, particulate filter respirator complying with an approved standard if a risk assessment indicates this is necessary.

Skydrol® LD4 Fire Resistant Hydraulic Fluid

Version	Revision Date:	SDS Number:	Date of last issue: 06/02/2015
2.2	08/09/2016	150000093409	Date of first issue: 10/24/2013

SDSUS / PRD / 0001

Respirator selection, use, and maintenance must be in accordance with regulatory requirements, if applicable. If engineering controls do not maintain airborne concentrations below recommended exposure limits (where applicable) or to an acceptable level (in countries where exposure limits have not been established), an approved respirator must be worn.

Hand protection

Remarks : Wear suitable gloves. Please observe the instructions regarding permeability and breakthrough time which are provided by the supplier of the gloves. Also take into consideration the specific local conditions under which the product is used, such as the danger of cuts, abrasion, and the contact time. After contamination with product change the gloves immediately and dispose of them according to relevant national and local regulations.

Eye protection : Wear safety glasses with side shields (or goggles).

Skin and body protection : Wear suitable protective clothing.

Protective measures : Ensure that eye flushing systems and safety showers are located close to the working place.

SECTION 9. PHYSICAL AND CHEMICAL PROPERTIES

Appearance	: oily
Colour	: purple
Odour	: odourless
pH	: No data available
Melting point/range	: < -62 °C
Flash point	: 160 °C Method: Cleveland open cup
Vapour pressure	: 0.27 hPa (25 °C)
Relative density	: 1.004 - 1.014 (25 °C)
Viscosity	
Viscosity, kinematic	: < 2000 mm ² /s (-54 °C)
	11.15 mm ² /s (38 °C)
	3.83 mm ² /s (99 °C)

Skydrol® LD4 Fire Resistant Hydraulic Fluid

Version 2.2 Revision Date: 08/09/2016 SDS Number: 150000093409 Date of last issue: 06/02/2015
Date of first issue: 10/24/2013
SDSUS / PRD / 0001

SECTION 10. STABILITY AND REACTIVITY

Reactivity : None reasonably foreseeable.

Chemical stability : Stable under normal conditions.

Possibility of hazardous reactions : None known.

Conditions to avoid : None known.

Incompatible materials : Strong oxidizing agents

Hazardous decomposition products : Emits acrid smoke and fumes when heated to decomposition.

SECTION 11. TOXICOLOGICAL INFORMATION**Acute toxicity**

Not classified based on available information.

Product:

Acute oral toxicity : LD50 (Rat, Male and Female): 2,100 mg/kg

Acute inhalation toxicity : LC50 (Rat, male): > 5.8 mg/l
Exposure time: 4 h
Test atmosphere: dust/mist
Assessment: The substance or mixture has no acute inhalation toxicity
Remarks: (highest concentration tested)

Acute dermal toxicity : LD50 Dermal (Rabbit, Male and Female): > 3,160 mg/kg
Assessment: The substance or mixture has no acute dermal toxicity

Components:**Tributyl phosphate:**

Acute oral toxicity : LD50 Oral (Rat, Male and Female): 1,553 mg/kg
Method: Acute Oral Toxicity
Assessment: Harmful if swallowed.

Acute inhalation toxicity : LC50 (Rat, Male and Female): > 4.242 mg/l
Exposure time: 4 h
Test atmosphere: dust/mist
Assessment: The substance or mixture has no acute inhalation toxicity

Acute dermal toxicity : LD50 Dermal (Rabbit, Male and Female): > 3,100 mg/kg
Assessment: The substance or mixture has no acute dermal toxicity

Dibutylphenylphosphate:

Skydrol® LD4 Fire Resistant Hydraulic Fluid

Version 2.2 Revision Date: 08/09/2016 SDS Number: 150000093409 Date of last issue: 06/02/2015
Date of first issue: 10/24/2013
SDSUS / PRD / 0001

Acute oral toxicity : Acute toxicity estimate (Rat, Male and Female): 2,400 - 3,000 mg/kg
Assessment: Not classified

Acute inhalation toxicity : LCLo (Rat, Male and Female): > 5 mg/l
Exposure time: 4 h
Test atmosphere: dust/mist

LC50 (Rat, Male and Female): > 5 mg/l
Exposure time: 4 h
Test atmosphere: dust/mist
Assessment: Not classified

Acute dermal toxicity : LD50 Dermal (Rabbit, Male and Female): > 5,000 mg/kg
Assessment: Not classified

7-Oxabicyclo[4.1.0]heptane-3-carboxylic acid, 2-ethylhexyl ester:

Acute oral toxicity : LD50 Oral (Rat, Male and Female): 4,470 mg/kg

Acute dermal toxicity : LD50 Dermal (Rabbit, Male and Female): > 7,940 mg/kg

butylated hydroxytoluene:

Acute oral toxicity : LD50 Oral (Rat): > 6,000 mg/kg

Acute dermal toxicity : LD50 Dermal (Guinea pig): > 20,000 mg/kg

Skin corrosion/irritation

Causes skin irritation.

Product:

Species: Rabbit
Exposure time: 24 h
Assessment: irritating
Result: moderate irritation

Components:**Tributyl phosphate:**

Species: Rabbit
Exposure time: 4 h
Assessment: Causes skin irritation.
Method: Acute Dermal Irritation / Corrosion
Result: irritating

Dibutylphenylphosphate:

Species: Rabbit
Assessment: Not classified

Species: Humans
Exposure time: 24 h
Assessment: Not classified

7-Oxabicyclo[4.1.0]heptane-3-carboxylic acid, 2-ethylhexyl ester:

Species: Rabbit

Skydrol® LD4 Fire Resistant Hydraulic Fluid

Version 2.2 Revision Date: 08/09/2016 SDS Number: 150000093409 Date of last issue: 06/02/2015
Date of first issue: 10/24/2013
SDSUS / PRD / 0001

Exposure time: 24 h
Assessment: Not classified as hazardous.
Result: slight to moderate irritation

butylated hydroxytoluene:

Species: Rabbit
Exposure time: 24 h
Result: very slight

Serious eye damage/eye irritation

Not classified based on available information.

Product:

Species: Rabbit
Result: slight
Exposure time: 24 h
Assessment: Not classified

Components:**Tributyl phosphate:**

Species: Rabbit
Result: slight irritation
Exposure time: 24 h
Assessment: Not classified
Method: Acute Eye Irritation / Corrosion

Dibutylphenylphosphate:

Species: Rabbit
Result: slight
Assessment: Not classified

7-Oxabicyclo[4.1.0]heptane-3-carboxylic acid, 2-ethylhexyl ester:

Species: Rabbit
Result: slight irritation
Exposure time: 24 h
Assessment: Not classified

butylated hydroxytoluene:

Species: Rabbit
Result: none

Respiratory or skin sensitisation

Skin sensitisation: Not classified based on available information.
Respiratory sensitisation: Not classified based on available information.

Product:

Test Type: Human experience
Assessment: Not classified
Method: Human Repeat Insult Patch Test
Result: Does not cause skin sensitisation.

Components:

Skydrol® LD4 Fire Resistant Hydraulic Fluid

Version 2.2 Revision Date: 08/09/2016 SDS Number: 150000093409 Date of last issue: 06/02/2015
Date of first issue: 10/24/2013
SDSUS / PRD / 0001

Tributyl phosphate:

Test Type: Skin Sensitization
Species: Guinea pig
Assessment: Not classified
Result: Does not cause skin sensitisation.

Test Type: Skin Sensitization
Species: Humans
Assessment: Not classified
Result: Does not cause skin sensitisation.

Dibutylphenylphosphate:

Test Type: Human experience
Species: Humans
Assessment: Not classified
Result: non-sensitizing

7-Oxabicyclo[4.1.0]heptane-3-carboxylic acid, 2-ethylhexyl ester:

Test Type: Skin Sensitization
Species: Guinea pig
Result: May cause sensitisation by skin contact.

butylated hydroxytoluene:

Test Type: Skin sensitisation
Species: Guinea pig
Result: non-sensitizing

Germ cell mutagenicity

Not classified based on available information.

Product:

Genotoxicity in vitro : Test Type: Salmonella typhimurium assay (Ames test)
Metabolic activation: +/- activation
Result: negative

: Test Type: Mutagenicity - Mammalian
Metabolic activation: +/- activation
Method: In vitro Mammalian Chromosome Aberration Test
Result: negative

Components:**Tributyl phosphate:**

Genotoxicity in vitro : Test Type: Mutagenicity - Bacterial
Metabolic activation: +/- activation
Method: Bacterial Reverse Mutation Assay
Result: negative

: Test Type: Mutagenicity - Mammalian
Metabolic activation: +/- activation
Method: In vitro Mammalian Chromosome Aberration Test
Result: equivocal

Genotoxicity in vivo : Species: Rat (Male and Female)

Skydrol® LD4 Fire Resistant Hydraulic Fluid

Version 2.2 Revision Date: 08/09/2016 SDS Number: 150000093409 Date of last issue: 06/02/2015
Date of first issue: 10/24/2013
SDSUS / PRD / 0001

Application Route: oral: gavage
Method: Mammalian Bone Marrow Chromosome Aberration Test
Result: negative

Dibutylphenylphosphate:

Genotoxicity in vitro

- : Test Type: Salmonella typhimurium assay (Ames test)
Metabolic activation: +/- activation
Method: Bacterial Reverse Mutation Assay
Result: negative
- : Test Type: Mutagenicity - Mammalian
Metabolic activation: +/- activation
Method: In vitro Mammalian Cell Gene Mutation Test
Result: negative
- : Test Type: Chromosome aberration test in vitro
Metabolic activation: +/- activation
Method: In vitro Mammalian Chromosome Aberration Test
Result: negative
- : Test Type: Mutagenicity - Mammalian
Metabolic activation: - activation
Method: Genetic Toxicology: DNA Damage and Repair, Un-scheduled DNA Synthesis in Mammalian Cells In Vitro
Result: negative

Genotoxicity in vivo

- : Species: Rat (Male and Female)
Application Route: intraperitoneal injection
Result: negative

7-Oxabicyclo[4.1.0]heptane-3-carboxylic acid, 2-ethylhexyl ester:

Genotoxicity in vitro

- : Test Type: Salmonella typhimurium assay (Ames test)
Metabolic activation: +/- activation
Method: Bacterial Reverse Mutation Assay
Result: negative
- : Test Type: Mutagenicity - Mammalian
Metabolic activation: +/- activation
Method: In vitro Mammalian Chromosome Aberration Test
Result: equivocal
- : Test Type: Mutagenicity - Mammalian
Metabolic activation: +/- activation
Method: In vitro Mammalian Cell Gene Mutation Test
Result: negative

Genotoxicity in vivo

- : Species: Rat (Male and Female)
Application Route: intraperitoneal injection
Method: Mammalian Bone Marrow Chromosome Aberration Test
Result: equivocal

Skydrol® LD4 Fire Resistant Hydraulic Fluid

Version Revision Date: SDS Number: Date of last issue: 06/02/2015
 2.2 08/09/2016 150000093409 Date of first issue: 10/24/2013
 SDSUS / PRD / 0001

Carcinogenicity

Suspected of causing cancer.

Components:**Tributyl phosphate:**

Species: Rat, (Male and Female)
 Application Route: Ingestion
 Method: EPA OTS 798.3300
 Remarks: Limited evidence of a carcinogenic effect.
 May cause cancer.

IARC

No component of this product present at levels greater than or equal to 0.1% is identified as probable, possible or confirmed human carcinogen by IARC.

OSHA

No component of this product present at levels greater than or equal to 0.1% is identified as a carcinogen or potential carcinogen by OSHA.

NTP

No component of this product present at levels greater than or equal to 0.1% is identified as a known or anticipated carcinogen by NTP.

Reproductive toxicity

Not classified based on available information.

Components:**Tributyl phosphate:**

Effects on fertility :
 : Test Type: Two Generation Reproductive Toxicity Study
 : Species: Rat
 : Sex: Male and Female
 : Application Route: Ingestion
 : NOAEL: 225 mg/kg,
 : Method: EPA OTS 798.4900

Effects on foetal development : Species: Rat
 : Application Route: Oral
 : 750 mg/kg
 : Method: EPA OTS 798.4900

Dibutylphenylphosphate:

Effects on fertility :
 : Species: Rat
 : Sex: Male and Female
 : Application Route: Ingestion
 : NOAEL: 5 mg/l,
 : F1: Lowest observed adverse effect level 50 mg/kg,
 : F2: Lowest observed adverse effect level 50 mg/kg,
 : Method: EPA OTS 798.4900

Effects on foetal development : Species: Rat
 : Application Route: oral (gavage)

Skydrol® LD4 Fire Resistant Hydraulic Fluid

Version 2.2 Revision Date: 08/09/2016 SDS Number: 150000093409 Date of last issue: 06/02/2015
Date of first issue: 10/24/2013
SDSUS / PRD / 0001

300 mg/kg
3 mg/kg

STOT - single exposure

Not classified based on available information.

Components:**Tributyl phosphate:**

Assessment: Based on available data, the classification criteria are not met.

Dibutylphenylphosphate:

Assessment: Not classified

STOT - repeated exposure

Not classified based on available information.

Components:**Tributyl phosphate:**

Assessment: Based on available data, the classification criteria are not met.

Dibutylphenylphosphate:

Exposure routes: inhalation (dust/mist/fume)

Target Organs: Respiratory system

Assessment: Not classified

Repeated dose toxicity**Product:**

Species: Rat, Male and Female

NOAEL: 40 mg/m³

Application Route: Inhalation

Exposure time: 28 days

Target Organs: Blood, Respiratory system

Remarks: Irritating to eyes and respiratory system.

Components:**Tributyl phosphate:**

Species: Mouse, Male and Female

NOEL: 75 mg/kg

Application Route: in feed

Exposure time: 90 days

Dibutylphenylphosphate:

Species: Rat, Male and Female

NOAEL: 5 mg/kg

LOAEL: 50 mg/kg

Application Route: oral (feed)

Exposure time: 90 days

Species: Rat, Male and Female

NOAEC: 5 mg/m³

Application Route: Inhalation

Skydrol® LD4 Fire Resistant Hydraulic Fluid

Version 2.2 Revision Date: 08/09/2016 SDS Number: 150000093409 Date of last issue: 06/02/2015
Date of first issue: 10/24/2013
SDSUS / PRD / 0001

Exposure time: 90 days

Species: Rabbit, Male and Female
No observed adverse effect level: 100 mg/kg bw/day
Application Route: Dermal Study
Exposure time: 21 d

Aspiration toxicity

Not classified based on available information.

Product:

Not applicable

Components:

7-Oxabicyclo[4.1.0]heptane-3-carboxylic acid, 2-ethylhexyl ester:

Not applicable

Experience with human exposure**Product:**

Inhalation : Remarks: None known.
Skin contact : Remarks: Causes skin irritation.
Eye contact : Remarks: Contact with the eyes may be very painful but does not cause damage.
Ingestion : Remarks: None known.

SECTION 12. ECOLOGICAL INFORMATION**Ecotoxicity****Product:**

Toxicity to fish : LC50 (Oncorhynchus mykiss (rainbow trout)): 5.2 mg/l
Exposure time: 96 h
Toxicity to daphnia and other aquatic invertebrates : LC50 (Daphnia magna (Water flea)): 5.8 mg/l
Exposure time: 48 h
Toxicity to algae : EC50 (Selenastrum capricornutum (green algae)): 8.2 mg/l
Exposure time: 96 h

Components:**Tributyl phosphate:**

Toxicity to fish : LC50 (Oncorhynchus mykiss (rainbow trout)): 4.2 mg/l
Exposure time: 96 h
Toxicity to daphnia and other : EC50 (Daphnia magna (Water flea)): 1.8 mg/l

Skydrol® LD4 Fire Resistant Hydraulic Fluid

Version 2.2 Revision Date: 08/09/2016 SDS Number: 150000093409 Date of last issue: 06/02/2015
 Date of first issue: 10/24/2013
 SDSUS / PRD / 0001

aquatic invertebrates	Exposure time: 48 h
Toxicity to algae	: EC50 (Desmodesmus subspicatus (Scenedesmus subspicatus)): 1.1 mg/l Exposure time: 72 h
Toxicity to fish (Chronic toxicity)	: NOEC (Oncorhynchus mykiss (rainbow trout)): 0.82 mg/l Exposure time: 95 d 1.7 mg/l
Toxicity to daphnia and other aquatic invertebrates (Chronic toxicity)	: NOEC (Daphnia magna (Water flea)): 1.3 mg/l Exposure time: 21 d
Dibutylphenylphosphate:	
Toxicity to fish	: LL50 (Cyprinus carpio (Carp)): 1.8 mg/l Exposure time: 96 h
Toxicity to daphnia and other aquatic invertebrates	: EC50 (Daphnia magna (Water flea)): 1.4 mg/l Exposure time: 48 h
Toxicity to algae	: EL50 (Selenastrum capricornutum (green algae)): 9.6 mg/l Exposure time: 72 h Method: EL50 method of the water accommodated fraction (W.A.F.) NOELR (Selenastrum capricornutum (green algae)): 3.5 mg/l Exposure time: 72 h Method: EL50 method of the water accommodated fraction (W.A.F.)
Toxicity to fish (Chronic toxicity)	: NOEC (Oncorhynchus mykiss (rainbow trout)): > 0.11 mg/l Exposure time: 60 d
Toxicity to daphnia and other aquatic invertebrates (Chronic toxicity)	: NOEC (Daphnia magna (Water flea)): 0.106 mg/l Exposure time: 21 d
butylated hydroxytoluene:	
Toxicity to fish	: LC50 (Fish): 0.199 mg/l Exposure time: 96 h
Toxicity to daphnia and other aquatic invertebrates	: EC50 (Daphnia (water flea)): 0.48 mg/l Exposure time: 48 h
Toxicity to algae	: EC50 (Chlorella pyrenoidosa (aglae)): 0.758 mg/l Exposure time: 96 h

Persistence and degradability**Product:**

Biochemical Oxygen Demand (BOD) : Remarks: not determined

Skydrol® LD4 Fire Resistant Hydraulic Fluid

Version 2.2 Revision Date: 08/09/2016 SDS Number: 150000093409 Date of last issue: 06/02/2015
Date of first issue: 10/24/2013
SDSUS / PRD / 0001

Chemical Oxygen Demand (COD) : Remarks: not determined

Components:**Tributyl phosphate:**

Biodegradability : Result: Readily biodegradable

Dibutylphenylphosphate:

Biodegradability : Method: Ready Biodegradability: Manometric Respirometry Test

Remarks: Readily biodegradable

Method: Ready Biodegradability: Modified MITI Test (I)

Remarks: Not readily biodegradable.

7-Oxabicyclo[4.1.0]heptane-3-carboxylic acid, 2-ethylhexyl ester:

Biodegradability : Concentration: 100 mg/l
Method: Ready Biodegradability: Modified MITI Test (I)
Remarks: Readily biodegradable

Bioaccumulative potential**Components:****Tributyl phosphate:**

Bioaccumulation : Species: Cyprinus carpio (Carp)
Bioconcentration factor (BCF): 20
Exposure time: 56 d
Method: OECD Test Guideline 305

Bioconcentration factor (BCF): 35

Exposure time: 38 d

Partition coefficient: n-octanol/water : Pow: 10,100

Dibutylphenylphosphate:

Bioaccumulation : Species: Cyprinus carpio (Carp)
Bioconcentration factor (BCF): 35
Method: OECD Test Guideline 305

Mobility in soil

No data available

Other adverse effects**Product:**

Ozone-Depletion Potential :

Regulation: 40 CFR Protection of Environment; Part 82 Protection of Stratospheric Ozone - CAA Section 602 Class I Substances

Skydrol® LD4 Fire Resistant Hydraulic Fluid

Version Revision Date: SDS Number: Date of last issue: 06/02/2015
2.2 08/09/2016 150000093409 Date of first issue: 10/24/2013
SDSUS / PRD / 0001

Remarks: This product neither contains, nor was manufactured with a Class I or Class II ODS as defined by the U.S. Clean Air Act Section 602 (40 CFR 82, Subpt. A, App.A + B).

SECTION 13. DISPOSAL CONSIDERATIONS**Disposal methods**

Waste from residues : This product meets the criteria for a synthetic used oil under the U.S. EPA Standards for the Management of Used Oil (40 CFR 279). Those standards govern recycling and disposal in lieu of 40 CFR 260 -272 of the Federal hazardous waste program in states that have adopted these used oil regulations. Consult your attorney or appropriate regulatory official to be sure these standards have been adopted in your state. Recycle or burn in accordance with the applicable standards. Dispose of in accordance with local regulations.

SECTION 14. TRANSPORT INFORMATION**International Regulation****IATA-DGR**

Not regulated as a dangerous good

IMDG-Code

Not regulated as a dangerous good

Transport in bulk according to Annex II of MARPOL 73/78 and the IBC Code

Not applicable for product as supplied.

National Regulations**49 CFR**

Not regulated as a dangerous good

SECTION 15. REGULATORY INFORMATION**EPCRA - Emergency Planning and Community Right-to-Know Act****SARA 311/312 Hazards**

: Acute Health Hazard
Chronic Health Hazard

SARA 302

: No chemicals in this material are subject to the reporting requirements of SARA Title III, Section 302.

SARA 313

: This material does not contain any chemical components with known CAS numbers that exceed the threshold (De Minimis) reporting levels established by SARA Title III, Section 313.

Clean Air Act

Skydrol® LD4 Fire Resistant Hydraulic Fluid

Version Revision Date: SDS Number: Date of last issue: 06/02/2015
 2.2 08/09/2016 150000093409 Date of first issue: 10/24/2013
 SDSUS / PRD / 0001

Association; IBC - International Code for the Construction and Equipment of Ships carrying Dangerous Chemicals in Bulk; IC50 - Half maximal inhibitory concentration; ICAO - International Civil Aviation Organization; IECSC - Inventory of Existing Chemical Substances in China; IMDG - International Maritime Dangerous Goods; IMO - International Maritime Organization; ISHL - Industrial Safety and Health Law (Japan); ISO - International Organisation for Standardization; KECI - Korea Existing Chemicals Inventory; LC50 - Lethal Concentration to 50 % of a test population; LD50 - Lethal Dose to 50% of a test population (Median Lethal Dose); MARPOL - International Convention for the Prevention of Pollution from Ships; MSHA - Mine Safety and Health Administration; n.o.s. - Not Otherwise Specified; NFPA - National Fire Protection Association; NO(A)EC - No Observed (Adverse) Effect Concentration; NO(A)EL - No Observed (Adverse) Effect Level; NOELR - No Observable Effect Loading Rate; NTP - National Toxicology Program; NZIoC - New Zealand Inventory of Chemicals; OECD - Organization for Economic Co-operation and Development; OPPTS - Office of Chemical Safety and Pollution Prevention; PBT - Persistent, Bioaccumulative and Toxic substance; PICCS - Philippines Inventory of Chemicals and Chemical Substances; (Q)SAR - (Quantitative) Structure Activity Relationship; RCRA - Resource Conservation and Recovery Act; REACH - Regulation (EC) No 1907/2006 of the European Parliament and of the Council concerning the Registration, Evaluation, Authorisation and Restriction of Chemicals; RQ - Reportable Quantity; SADT - Self-Accelerating Decomposition Temperature; SARA - Superfund Amendments and Reauthorization Act; SDS - Safety Data Sheet; TCSI - Taiwan Chemical Substance Inventory; TSCA - Toxic Substances Control Act (United States); UN - United Nations; UNRTDG - United Nations Recommendations on the Transport of Dangerous Goods; vPvB - Very Persistent and Very Bioaccumulative

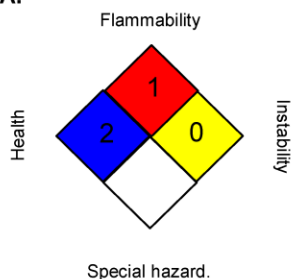
Further information**NFPA:****HMIS III:**

HEALTH	2*
FLAMMABILITY	1
PHYSICAL HAZARD	0

0 = not significant, 1 = Slight,
 2 = Moderate, 3 = High
 4 = Extreme, * = Chronic

Sources of key data used to compile the Safety Data Sheet : www.EastmanAviationSolutions.com
 Revision Date : 08/09/2016

The information provided in this Safety Data Sheet is correct to the best of our knowledge, information and belief at the date of its publication. The information given is designed only as a guidance for safe handling, use, processing, storage, transportation, disposal and release and is not to be considered a warranty or quality specification. The information relates only to the specific material designated and may not be valid for such material used in combination with any other materials or in any process, unless specified in the text.

Skydrol® LD4 Fire Resistant Hydraulic Fluid

Version	Revision Date:	SDS Number:	Date of last issue: 06/02/2015
2.2	08/09/2016	150000093409	Date of first issue: 10/24/2013

SDSUS / PRD / 0001

US / EN



APPENDIX VIII

Instrument Certification Notice



Instrument Certification Notice

The gauge Certificates of Calibration supplied for the gauge(s) on this unit contain the calibration data for the actual instrument calibrated, along with the calibration date of the **STANDARD** used to perform the calibration check.

The due date for re-calibration of the instrument should be based upon the date the instrument was placed in service in your facility. Re-calibration should be done on a periodic basis as dictated by the end user's quality system or other overriding requirements.

Note that Tronair, Inc. does not supply certificates of calibration on pyrometers unless requested at the time of placed order. This instrument is considered a reference indicator only and is not critical to the test(s) being performed on the aircraft.