

**58X3 Series
5813, 5823, 5833, 5843
Hydraulic Power Unit**



04/2023 – Rev. 02

**For Spare Parts, Operations & Service Manuals or Service Needs
Scan the QR code or visit Tronair.com/aftermarket**



REVISION	DATE	TEXT AFFECTED
01	06/2022	Original release
02	04/2023	Modified 9.5.2 Return Filter Element, added 5843

TABLE OF CONTENTS

PAGE

1.0	PRODUCT INFORMATION	1
1.1	DESCRIPTION.....	1
1.2	MODEL & SERIAL NUMBER.....	1
1.3	MANUFACTURER.....	1
1.4	FUNCTION.....	1
1.5	REQUIREMENTS.....	1
2.0	SAFETY INFORMATION	2
2.1	USAGE AND SAFETY INFORMATION.....	2
2.2	EXPLANATION OF WARNING & DANGER SIGNS.....	2
2.3	COMPONENT SAFETY FEATURES.....	2
2.4	FUNCTIONAL SAFETY FEATURES.....	2
2.5	PERSONAL PROTECTION EQUIPMENT.....	2
2.6	SAFETY GUIDELINES.....	2
2.7	GENERAL COMMENTS.....	2
3.0	PREPARATION PRIOR TO FIRST USE	3
3.1	GENERAL.....	3
3.2	SERVICING RESERVOIR.....	3
3.3	CONNECTING ELECTRICAL LEADS.....	3
4.0	TRAINING	3
4.1	TRAINING REQUIREMENTS.....	3
4.2	TRAINING PROGRAM.....	3
4.3	OPERATOR TRAINING.....	3
5.0	OPERATION	4
5.1	OPERATING PARAMETERS.....	4
5.2	NUMERICAL VALUES.....	4
5.2.1	Fluid.....	4
5.2.2	Physical.....	4
5.2.3	Motor Driven Hydraulic Pump.....	5
5.2.4	Electric Motor.....	5
5.2.5	Filters.....	5
5.2.6	Hand Pump (<i>Option M</i>).....	5
5.3	LOCATION & LAYOUT OF CONTROLS.....	6
5.3.1	Front Panel Controls.....	6
5.3.2	Electrical Control Panel.....	7
5.3.3	Hydraulic Control Panel.....	8
5.3.4	Rear Panel Controls.....	9
5.3.5	Hydraulic Pump Controls.....	10
5.3.6	Hand Pump Controls (<i>Option M</i>).....	11
5.3.7	Split System Controls (<i>Option C</i>).....	12
5.4	START UP PROCEDURES.....	13
5.4.1	Pump Rotation Check Procedure (First Time Use or Change of Electrical Supply Only).....	13
5.4.2	Initial Start Up of the HPU.....	13
5.5	PRELIMINARY ADJUSTMENTS FOR OPERATION.....	13
5.5.1	Flow Control Adjustment.....	13
5.5.2	Pressure Control Adjustment.....	14
5.5.3	Reservoir Selector Valve Operation.....	14
5.5.4	Bypass Valve Operation.....	14
5.5.5	RETURN BACK-PRESSURE VALVE OPERATION.....	15
5.5.6	RETURN SIGHTGAUGE.....	15
5.6	BLEEDING AIR FROM SYSTEM.....	15
5.6.1	To Easily Purge the Unit of Air.....	15
5.7	SPLIT SYSTEM OPERATION.....	15
5.7.1	To Operate the Split System.....	16
5.8	HAND PUMP OPERATION (<i>Option M</i>).....	16
5.8.1	To Operate the Hand Pump.....	16
5.9	SAMPLE VALVE.....	16
5.10	EMERGENCY SHUT DOWN PROCEDURE.....	16
5.11	DESCRIPTION OF ALARM SYSTEMS.....	16
5.11.1	High Fluid Temperature Indicator.....	16
5.11.2	Voltage/Phase Monitor Indicator.....	16
5.11.3	High and Low Reservoir Level Indicator (<i>Option L</i>).....	17
5.11.4	Clogged Filter Indicator Light.....	17
5.12	INFREQUENT HPU USE.....	17
5.12.1	Infrequent HPU Use Start Up Procedure.....	17
6.0	PACKAGING AND STORAGE	18

6.1	PACKAGING REQUIREMENTS	18
6.2	HANDLING	18
6.3	PACKAGING PROTECTION	18
6.4	LABELING OF PACKAGING	18
6.5	STORAGE COMPATIBILITY	18
6.6	STORAGE ENVIRONMENT	18
6.7	STORAGE SPACE AND HANDLING FACILITIES	18
7.0	TRANSPORTATION	18
8.0	TROUBLE SHOOTING	19
8.1	HPU WILL NOT START	19
8.2	NO FLOW	19
8.3	REDUCED FLOW	20
8.4	NO PRESSURE or REDUCED PRESSURE	20
8.5	FLUID OVERHEATS.....	20
8.6	HAND PUMP (<i>Option M</i>) IS NOT PUMPING FLUID.....	20
9.0	MAINTENANCE	21
9.1	GENERAL.....	21
9.2	ELECTRIC MOTOR	21
9.3	MOTOR DRIVEN HYDRAULIC PUMP	22
9.3.1	Motor Driven Hydraulic Pump Replacement Parts.....	22
9.3.2	Motor Driven Hydraulic Pump Replacement Kits List.....	22
9.4	HYDRAULIC FLUID	23
9.5	FILTERS	23
9.5.1	Pressure Filter Element.....	24
9.5.2	Return Filter Element	25
9.5.3	Hand Pump (<i>Option M</i>) Filter Element	26
9.5.4	Desiccant Air Filter	27
9.5.5	Pressure Filter Assembly with Electric Filter Clogging Indicator	28
9.5.6	Return Filter Assembly.....	29
9.6	HYDRAULIC HOSES.....	31
9.7	INSTRUMENT PANEL.....	33
9.7.1	Electric Panel	34
9.7.2	Hydraulic Panel	35
9.7.3	Control Block Assembly	36
9.7.3.a	System Pressure Relief Valve.....	37
9.7.3.b	Check Valve.....	38
9.7.3.c	Bypass Valve	39
9.7.4	Pump Flow Control.....	40
9.8	RESERVOIR ASSEMBLY.....	41
9.9	PRESSURE MANIFOLD ASSEMBLY.....	43
9.10	RETURN MANIFOLD ASSEMBLY	45
9.10.1	Return System Pressure Relief Valve	47
9.11	ELECTRICAL COMPONENTS	49
9.12	HEAT EXCHANGER ASSEMBLY.....	51
9.13	EXTERNAL COMPONENTS.....	52
9.14	ADDITIONAL FEATURES	53
9.14.1	50 ft (15.2 m) Hoses (<i>Option B</i>).....	53
9.14.2	Electric Reservoir Level (<i>Option L</i>).....	53
9.14.3	Hand Pump (<i>Option M</i>)	54
9.14.3.a	Two Stage Pump with Relief	55
9.14.4	Towing Trailer (<i>Option N</i>).....	57
9.15	REPLACEMENT LABELS PARTS LISTS.....	58
9.15.1	Base Unit	58
9.15.2	Fluid Labels.....	58
9.15.3	Filter Element Kit Labels	59
9.15.4	Split System (<i>Option C</i>) Labels	59
9.15.5	Hand Pump (<i>Option M</i>) Labels.....	59
10.0	PROVISION OF SPARES	60
10.1	SOURCE OF SPARE PARTS.....	60
10.2	RECOMMENDED SPARE PARTS LISTS	60
10.2.1	Spare Electrical Parts.....	60
10.2.2	Spare Parts	60
11.0	CALIBRATION OF INSTRUMENTATION	61
11.1	SOURCE OF CALIBRATION.....	61
11.2	ANALOG PRESSURE GAUGE – System Pressure	61
11.2.1	Self Calibration.....	61
11.3	ANALOG PRESSURE GAUGE (Hand Pump Pressure- <i>Option M Only</i>)	62
11.3.1	Self Calibration.....	62

11.4	ANALOG TEMPERATURE GAUGE (<i>Pyrometer</i>)	62
11.4.1	Self Calibration.....	62
12.0	IN SERVICE SUPPORT	63
13.0	GUARANTEES/LIMITATION OF LIABILITY	63
14.0	APPENDICES	63

This product can not be modified without the written approval of Tronair, Inc. Any modifications done without written approval voids all warranties and releases Tronair, Inc., its suppliers, distributors, employees, or financial institutions from any liability from consequences that may occur. Only Tronair OEM replacement parts shall be used.

1.0 PRODUCT INFORMATION

1.1 DESCRIPTION

Hydraulic Power Unit

Model Number Fluid Type

5813	MIL-PRF-5606
5823	MIL-PRF-83282
5833	Aviation Phosphate Ester, Type IV
5834	MIL-PRF-87257

1.2 MODEL & SERIAL NUMBER

Reference nameplate on unit.

1.3 MANUFACTURER

TRONAIR, Inc.
1 Air Cargo Pkwy East
Swanton, Ohio 43558 USA

Telephone: (419) 866-6301 or 800-426-6301
Fax: (419) 867-0634
E-mail: sales@tronair.com
Website: www.tronair.com

1.4 FUNCTION

The Hydraulic Power Unit (HPU) provides a source of clean, pressurized hydraulic fluid for performing required aircraft maintenance. An electric motor drives a pressure compensated piston pump. Filters are provided on the pressure and return systems. A bypass (dump) valve allows starting and stopping of the unit under a no-load, safe condition. The unit may use either the aircraft or on-board HPU reservoir. Cooling is provided for continuous operation.

1.5 REQUIREMENTS

Adequate electrical power must be provided for proper functioning of the HPU. See the unit nameplate for proper voltage and frequency. See the Technical Manual for proper sizing of electrical supply and protection equipment in the facility.

2.0 SAFETY INFORMATION

2.1 USAGE AND SAFETY INFORMATION

The HPU provides pressurized hydraulic fluid for performing aircraft maintenance.

To insure safe operations please read the following statements and understand their meaning. Also refer to your equipment manufacturer's manual for other important safety information. This manual contains safety precautions which are explained below. Please read carefully.



WARNING! — Warning is used to indicate the presence of a hazard that **can cause severe personal injury, death, or substantial property damage** if the warning notice is ignored.

CAUTION! — Caution is used to indicate the presence of a hazard that **will or can cause minor personal injury or property damage** if the caution notice is ignored.

2.2 EXPLANATION OF WARNING & DANGER SIGNS



Accidental Starts! Before servicing the HPU or equipment, always disconnect electrical power supply to prevent accidental starting.



Rotating Parts! Keep hands, feet, hair, and clothing away from all moving parts to prevent injury. Never operate the HPU with covers, shrouds, or guards removed.



Electrical Shock! Never touch electrical wires or components while the HPU is attached to the power source. They can be sources of electrical shock. **DO NOT** operate HPU with cabinet panels removed.



Pressurized Fluid! Before servicing the HPU or equipment, always open the bypass valve to relieve any residual pressure in the hydraulic system.

2.3 COMPONENT SAFETY FEATURES

- Pump/Motor coupling guard
- Sheet metal panels
- Pressure and return system relief valves
- Control circuit fuses
- Motor overload protection
- 3- Phase Power Input Fuses

2.4 FUNCTIONAL SAFETY FEATURES

- Emergency shut off switch
- Floor lock
- Calibration port shut off valve
- Fluid sample shut off valve

2.5 PERSONAL PROTECTION EQUIPMENT

- Safety glasses must be worn when operating the HPU.
- Additional equipment recommended by the fluid manufacturer (gloves, etc.). **Reference Appendix VII Material Safety Data Sheet pertaining to fluid(s).**

2.6 SAFETY GUIDELINES

- Operator must be properly trained prior to operating the HPU.
- HPU power switch must be in "Off" position when connecting or disconnecting hoses to the aircraft.
- Bypass valve must be in the "Open" position when starting or stopping the HPU.
- Electrical power must be disconnected from the HPU and the bypass valve must be in the "Open" position before servicing the HPU.

2.7 GENERAL COMMENTS

The HPU is intended to be operated by personnel trained in the proper use in conjunction with the aircraft maintenance manual.

The HPU must be used in accordance with the Technical and Operator Manuals and the intended aircraft.

3.0 PREPARATION PRIOR TO FIRST USE

3.1 GENERAL

Prior to operating the HPU, the user should become familiar with this Operator Manual.

3.2 SERVICING RESERVOIR

Fill the reservoir with the correct fluid (see label next to reservoir fill for correct type of fluid) until fluid level is above the minimum fluid level mark but below the maximum fluid level. See Figure 6.3.1 Front Panel Controls for reservoir fill location. NOTE: Leave the Reservoir Selector Valve in the Aircraft Reservoir position (as shipped) until the Hydraulic Power Unit reservoir has been filled.

3.3 CONNECTING ELECTRICAL LEADS



Electrical Shock! Never touch electrical wires or components while electrical power is attached. Only qualified electricians should connect the electrical leads.

Install the proper electrical plug onto the electrical cord. Read **5.0 Training** and **6.0 Operation** of this manual and become familiar with control locations. Reference **5.1 Electrical Power and Protection Requirements Table** for power requirements and fuse sizes. Follow instructions in **5.4.1 Pump Rotation Checking Procedure**.

WARNING!



Balanced three phase voltage must be available to prevent overheating and damage to the motor.

Voltage unbalanced between phases occurs when the voltages differ from one another.

Some reasons for imbalance are:

1. Unequal loading of each phase
2. Poor connections in the supply
3. Single phase condition caused by blown fuses or bad connections

If these conditions occur in the incoming power system, a protective device, such as a voltage monitor, should be installed on the machine to prevent motor damage.

4.0 TRAINING

4.1 TRAINING REQUIREMENTS

The employer of the operator is responsible for providing a training program sufficient for the safe operation of the HPU.

4.2 TRAINING PROGRAM

The employer provided operator training program should cover safety procedures concerning use of the HPU in and around the intended aircraft at the intended aircraft servicing location.

4.3 OPERATOR TRAINING

The operator training should provide the required training for safe operation of the HPU.

NOTE: Maintenance and Trouble Shooting are to be performed by a skilled and trained technician.

5.0 OPERATION

5.1 OPERATING PARAMETERS

- The user shall use the HPU in accordance with the aircraft manufacturer's instructions.
- The user shall operate the HPU in accordance with the Technical and Operator Manuals.
- The employer of the operator shall provide all necessary training.
- The electrical power supply for the HPU must include a fused disconnect using Type J or Type R fuses or equivalent magnetic type circuit breakers designed for protecting an electrical motor. This necessary equipment is for protection of the HPU, power cord, and customer-supplied plug and receptacle. *Reference the Table below:*

ELECTRICAL POWER AND PROTECTION REQUIREMENTS

60 Hz Applications			
Voltage	380	460	575
Full Load Amps	130	121	96.8
Locked Rotor Amps	908	789	632
Recommended Fuse Size	175	150	125
Maximum Fuse Size	200	175	150

50 Hz Applications			
Voltage	380	415	440
Full Load Amps	146	134	124
Locked Rotor Amps	849	778	734
Recommended Fuse Size	200	175	150
Maximum Fuse Size	200	200	175

5.2 NUMERICAL VALUES

5.2.1 Fluid

Model Number	Fluid Type
5813	MIL-PRF-5606
5823	MIL-PRF-83282
5833	Aviation Phosphate Ester, Type IV
5834	MIL-PRF-87257

5.2.2 Physical

Weight (Dry)	6,000 lbs (2722 kg) Estimated
Width	68-5/8 in (35 cm) Add 6.0 in (15.2 cm) for Split System
Height	62-7/8 in (25 cm)
Depth	101-13/16 in (40 cm) Add 11 in (25 cm) for trailer option
Power Cord	50 ft (15.24 m) long
Pressure Hoses	25 ft (7.62 m)..... Standard Length
	50 ft (15.24 m)..... Optional Length
	-16 (1 in, 25.4 mm)..... Working Diameter
Return Hoses	25 ft (7.62 m)..... Standard Length
	50 ft (15.24 m)..... Optional Length
	-24 (1½ in, 38.1 mm)..... Working Diameter
Hand Pump Hose	15 ft (4.57 m)..... Standard Length
	-4 (¼ in, 6.35 mm)..... Working Diameter

5.2.3 Motor Driven Hydraulic Pump

A pressure compensated, adjustable maximum volume piston pump.

- Maximum flow at 60 Hz 63 gpm (239 lpm)
- Maximum flow at 50 Hz 53 gpm (200 lpm)
- Maximum operating pressure at 50 Hz and 60 Hz 4,000 psi (276 bar)
- System pressure relief valve setting 4,250 psi (293 bar)
- Performance Curve for 50 Hz and 60 Hz

Chart Area

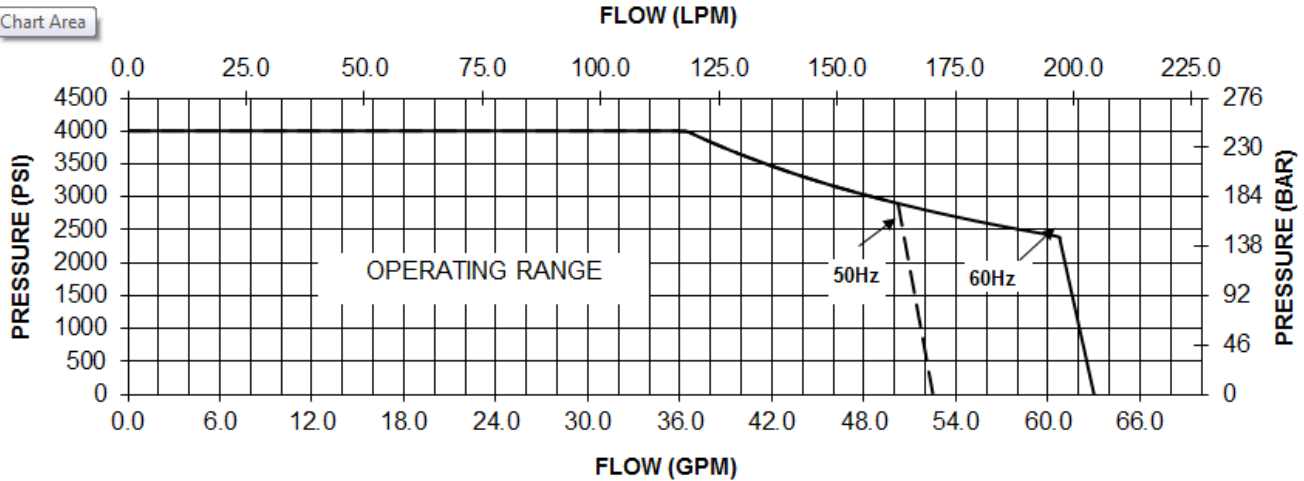

5.2.4 Electric Motor

A 100 horsepower, TEFC electric motor is the prime mover for the HPU. This is attached to the hydraulic pump using a pump/motor adapter and a spider/coupling rotating interface.

MOTOR POWER REQUIREMENTS

60 Hz Applications		50 Hz Applications	
Voltage	Full Load Amps	Voltage	Full Load Amps
380	130	380	146
460	121	415	134
575	96.8	440	124

5.2.5 Filters

- Pressure 2 micron rating, non-bypass high collapse microglass type. Non-cleanable element
- Return 5 micron rating, 25 psi (1.72 bar) bypass microglass type. Non-cleanable element
- Hand Pump (Option M) 2 micron rating, non-bypass microglass type. Non-cleanable element
- Air/Desiccant 3 micron filter, silica gel desiccant type. Non-cleanable element

5.2.6 Hand Pump (Option M)

Two stage hand pump, low pressure stage 0–500 psi (0–34.47 bars) and 500–5,000 psi (34.47–344.74 bars) high pressure stage. Pump automatically changes stage internally based on system pressure.

- Low Pressure Stage Piston Diameter 1½ in (38.1 mm)
 - Working Pressure 0–500 psi (0–34.47 bar)
 - Displacement/Stroke 2.1 in3 (34.4 cm3)
 - Force/100 psi (6.89 bar) 12.0 lbs/100 psi (7.74 N/bar)
- High Pressure Stage Piston Diameter 5/8 in (15.88 mm)
 - Working Pressure 500–5,000 psi (34.47–344.74)
 - Displacement/Stroke 0.4 in3 (6.55 cm3)
 - Force/100 psi (6.89 bar) 2.2 lbs/100 psi (1.42 N/bar)
- Pressure Relief Setting 5,250 psi (362.0 bar)

5.3 LOCATION & LAYOUT OF CONTROLS

5.3.1 Front Panel Controls

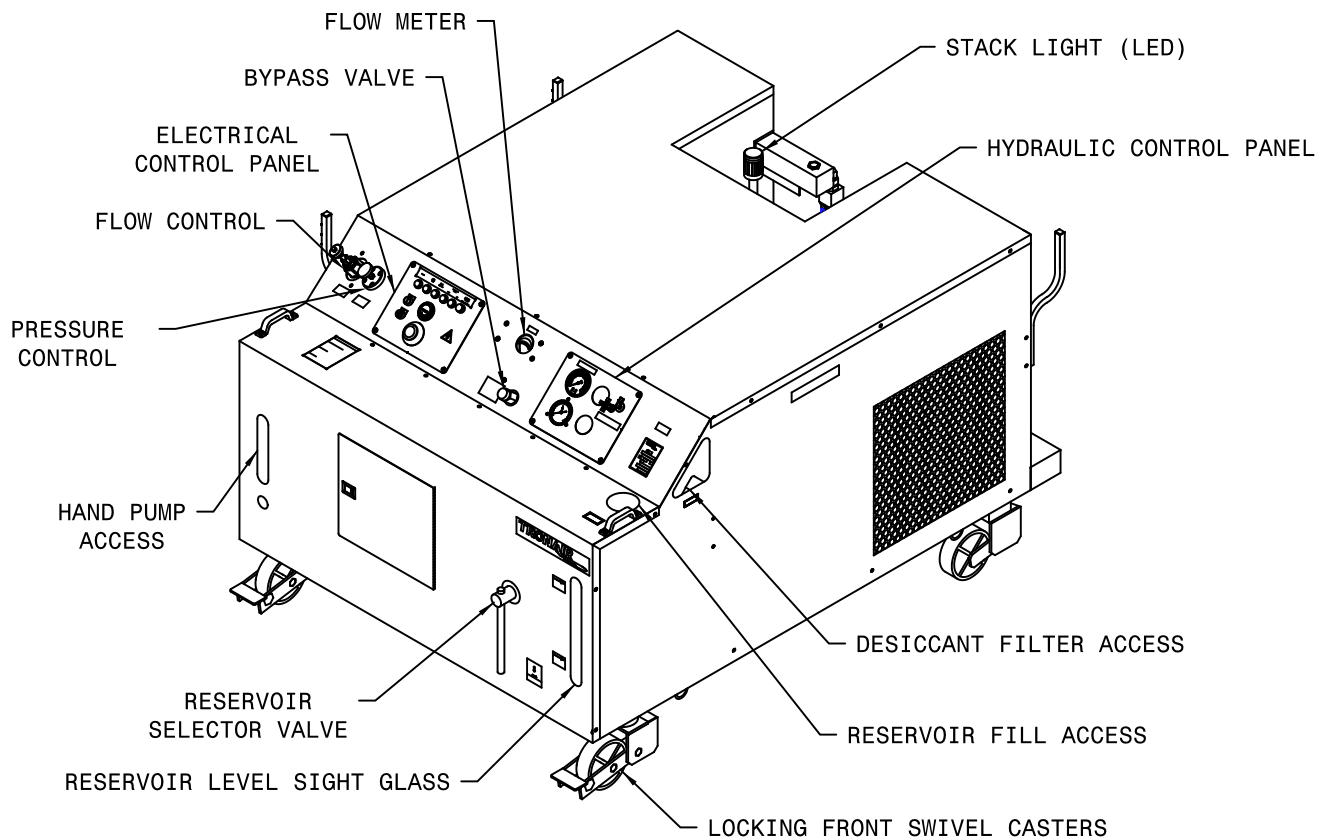

Electrical Control Panel	See Section 6.3.2
Hydraulic Control Panel	See Section 6.3.3
Bypass Valve	For loading and unloading the motor driven hydraulic pump
Flowmeter	Displays the flow from the motor driven hydraulic pump
Reservoir Selector	For selecting between using the aircraft reservoir or the HPU reservoir
Sight Gauge	Visual indicator displays the fluid level in the reservoir
Reservoir Fill Access	Locking cap for servicing the HPU reservoir
Desiccant Filter	Access to the reservoir air filter/desiccant filter
Hand Pump (<i>Option M</i>)	Access for hand pump and relief screw, handle stored inside
Locking Swivel Caster	Locking/unlocking, foot actuated and released locking front caster
Stack Light (<i>Option SL</i>)	Displays green LED light when unit is running
Flow Control	See 6.3.5 Hydraulic Pump Controls
Pressure Control	See 6.3.5 Hydraulic Pump Controls

5.3.2 Electrical Control Panel

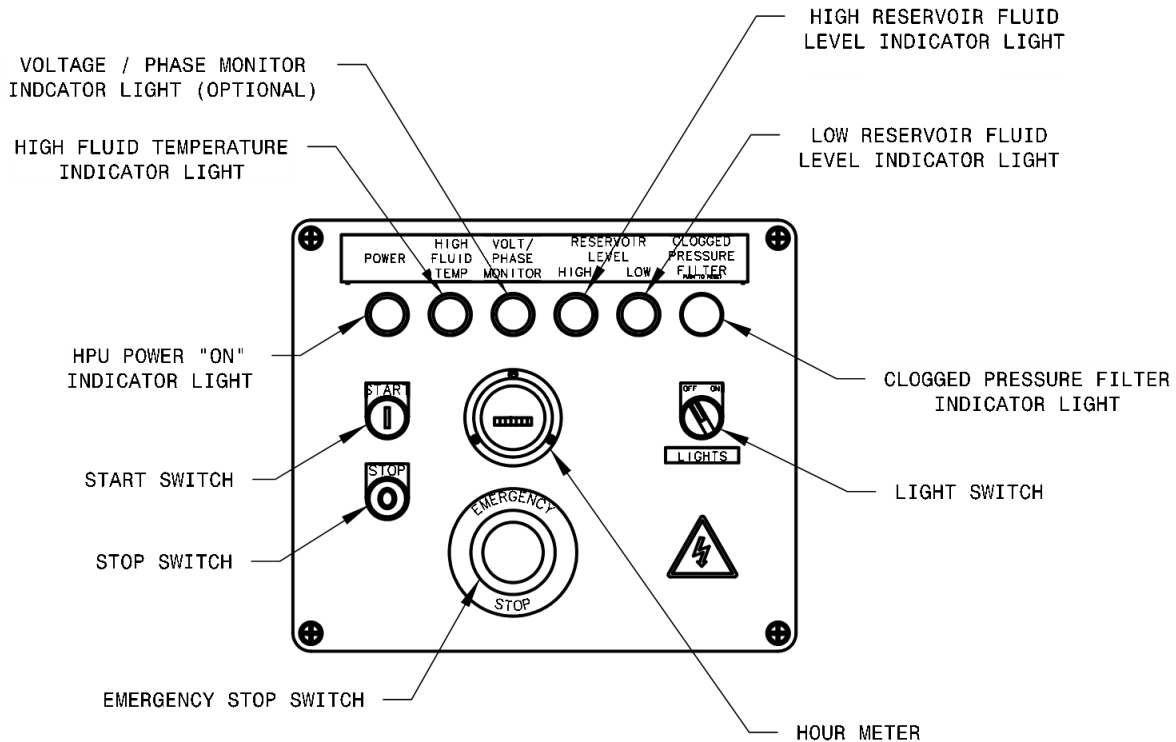

Emergency Stop	Removes power to all electrical devices, must turn to reset
Stop Switch	Turns off the electric motors driving the hydraulic pump and cooling fan
Start Switch	Turns on the electric motors driving the hydraulic pump and cooling fan
HPU Power "On" Indicator Light	Light is illuminated when the electric motors driving the hydraulic pump and cooling fan are on
High Fluid Temperature Indicator Light	Light is illuminated when the return fluid temperature reaches 170° F (77° C) or above. The HPU will shut down when light is illuminated. The HPU can be re-started when the fluid has cooled and the indicator light is off
High Reservoir Fluid Level Indicator Light	Light is illuminated when the fluid level in the reservoir is above the normal operating range. The HPU will shut down until the fluid level is restored to a normal operating level
Light Switch	Turns on lights for viewing return sight gauge instrumentation in low light conditions
Low Reservoir Fluid Level Indicator Light	Light is illuminated when the fluid level in the reservoir is below the normal operating range. The HPU will shut down until the fluid level is restored to a normal operating level
Voltage/Phase Monitor Indicator Light	Light is illuminated if any of the following conditions occur <ul style="list-style-type: none"> - Voltage imbalance between L1, L2, L3, greater than 5% - Loss of voltage from L1, L2, L3 - Over voltage from L1, L2, L3, greater than 5% - Change in phase orientation between L1, L2, L3. The HPU will shut down until the electrical problem is corrected
Clogged Pressure Filter Indicator Light	Light is illuminated when the pressure filter element requires changing. The HPU will not shut down when illuminated. Pressing the illuminated button will reset the light

5.3.3 Hydraulic Control Panel

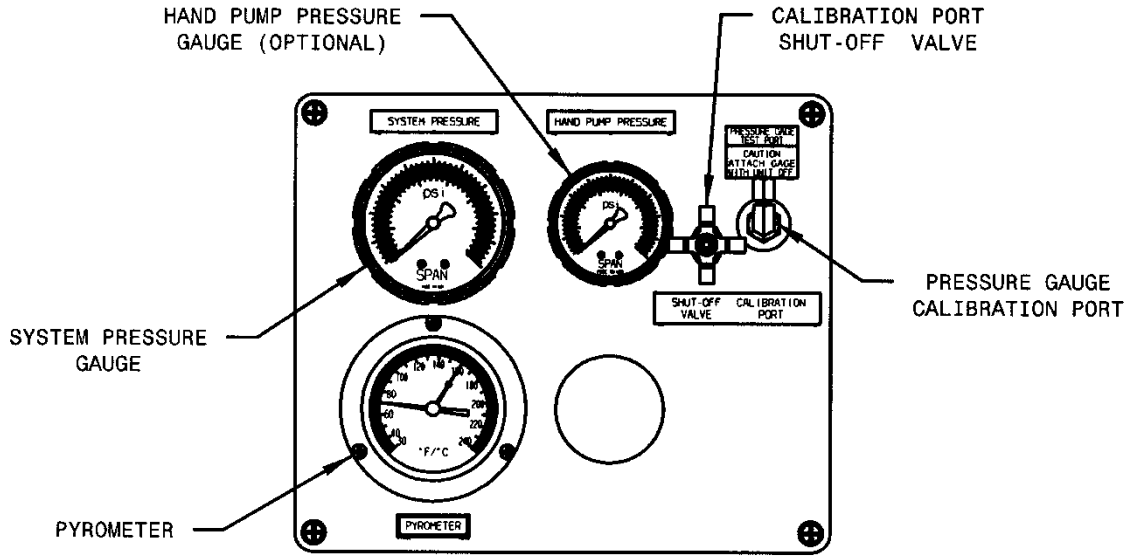

System Pressure Gauge	Displays the system pressure on an analog fluid dampened gauge
Pyrometer	Displays the fluid temperature in the return system on an analog gauge. A warning indicator preset to 160° F (71° C) warns of high operating temperature
Pressure Gauge Calibration Port	Allows for calibration of the system pressure gauge up to the operating pressure of HPU. Calibration port shut off valve must be used in conjunction with the calibration port
Calibration Port Shut Off Valve (Part of Calibration Port)	Used to shut off pressure to the calibration port. This valve should only be opened when the external standard gage is attached. (See Operation & Service Manual for proper procedure)
Hand Pump Pressure Gauge (Option M)	Displays the hand pump system pressure on an analog fluid dampened gauge

5.3.4 Rear Panel Controls

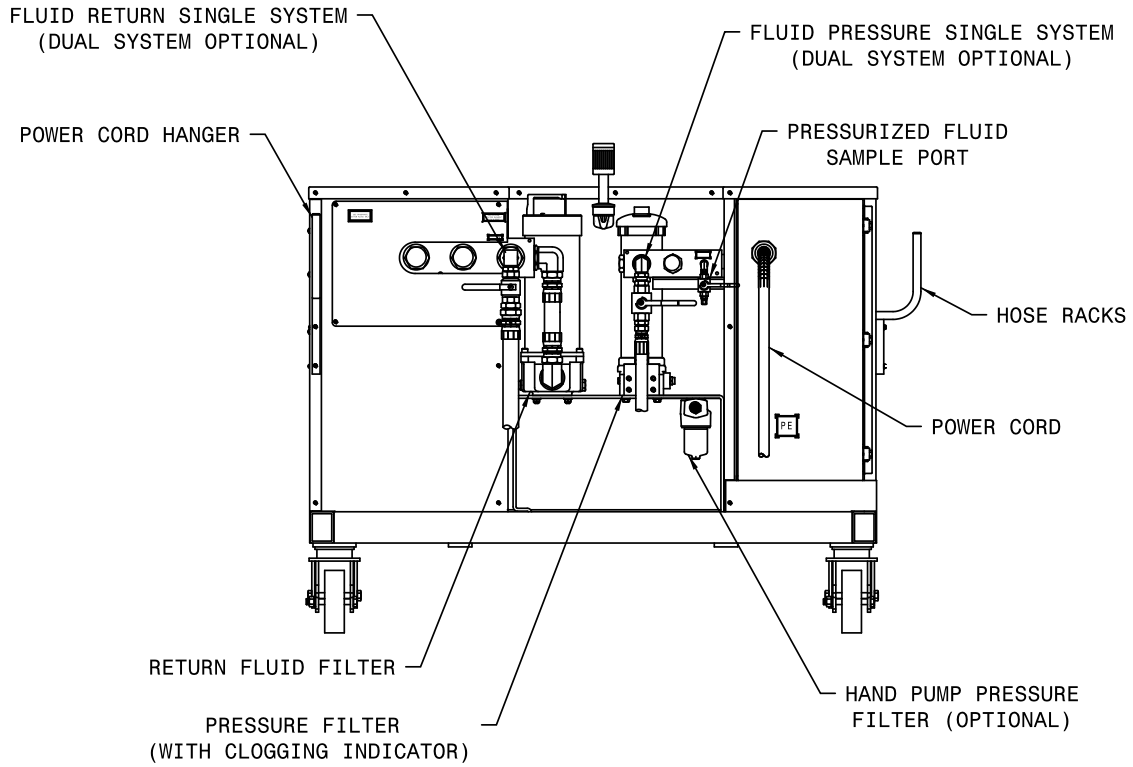

* Fluid Pressure System	The source of pressurized fluid from the HPU that flows to the aircraft pressure system through the pressure hose
* Fluid Return System	Fluid returning to the HPU from the aircraft that flows through the return hoses
Pressure Fluid Filter	Filters the pressurized fluid before it flows to the aircraft pressure system
Return Fluid Filter	Filters the fluid returning from the aircraft before it enters the HPU
Pressurized Fluid Sample Port	A sample valve is provided to obtain a fluid sample for analysis. In order to obtain a representative sample, it is suggested that ANSI/B93.19M-1972(R1993) be followed
Hand Pump Pressure Filter (Option M)	Filters the pressurized fluid before it flows to the aircraft system
Hose Racks	Location for storing the pressure, return and optional hand pump hoses when not in use
Power Cord Hanger	Location for storing the power cord when not in use

* **Split System (Optional) consists of two (2) each of these items.**

5.3.5 Hydraulic Pump Controls

The hydraulic pump flow control and pressure control are located through the pump control access door.

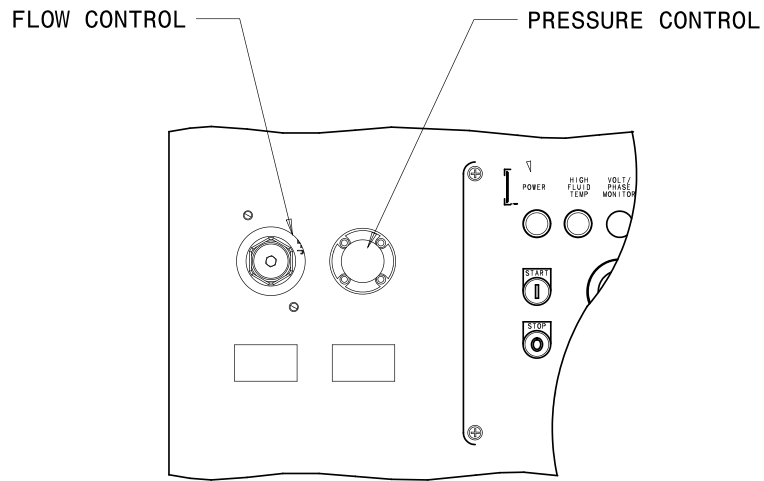

Flow Control	This control is used to set the maximum flow required from the HPU
Pressure Control	The pressure control is used to set the system pressure of the HPU during operation

5.3.6 Hand Pump Controls (*Option M*)
Reference 5.8 Hand Pump Operation

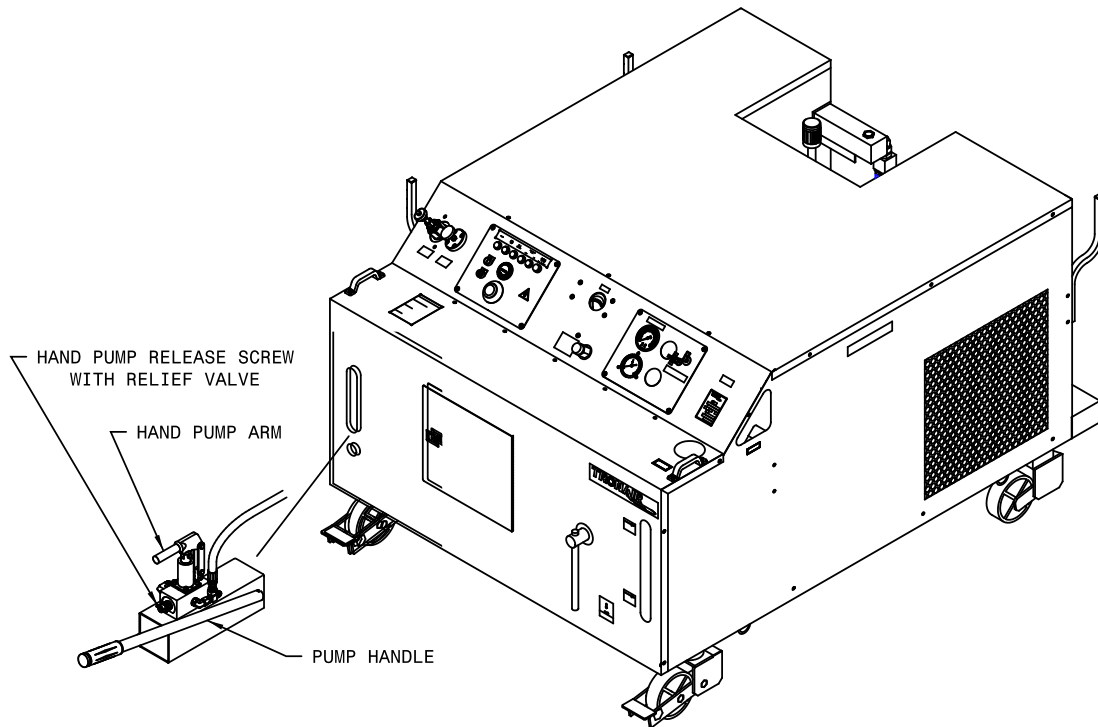

Pump Handle	Located inside the front access door is the hand pump handle used for opening and closing the hand pump relief screw and stroking the hand pump arm
Hand Pump Relief Screw	Accessed through the front panel opening, this screw allows opening and closing of the hand pump hydraulic circuit using the hand pump handle
Hand Pump Arm	The handle is used to access the hand pump arm used for up and down motion to produce hydraulic flow and pressure

5.3.7 Split System Controls (Option C)
Reference 5.7 Split System Operation

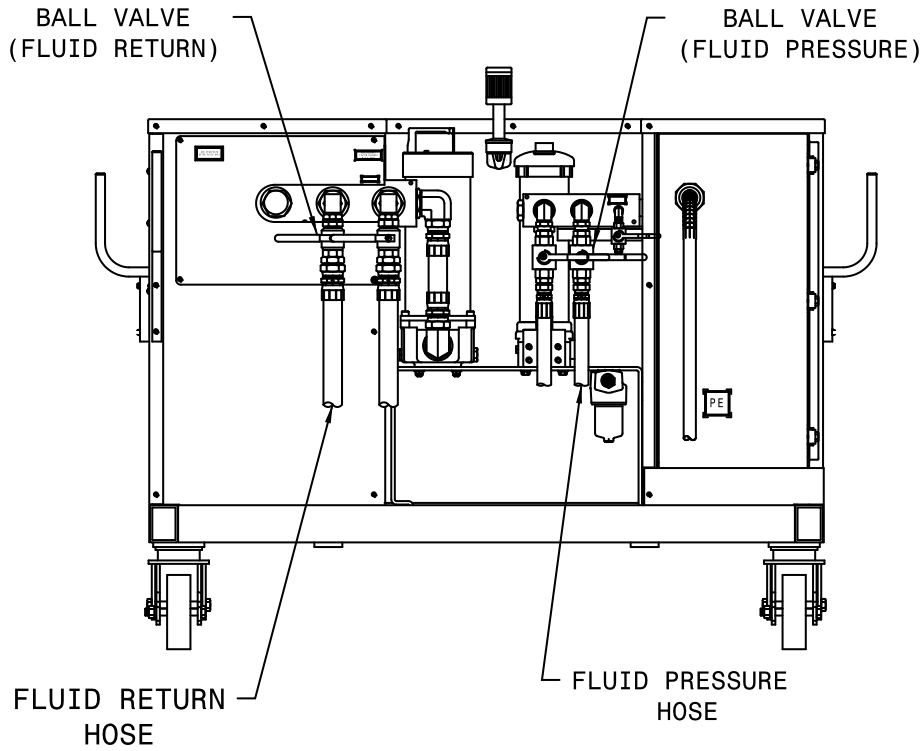

Fluid Pressure Ball Valve	Used to turn on and off the flow to separate aircraft systems. Always use in either fully open or fully closed position; never use in a partially open position
Fluid Pressure Hose	Connects HPU to aircraft pressure systems
Fluid Return Hose	Connects HPU to aircraft return systems
Fluid Return Ball Valve	Used to turn on and off the flow from separate aircraft systems. Always use in either fully open or fully closed position; never use in a partially open position



WARNING!

NEVER open or close split system valves without shutting off the Hydraulic Power Unit. Damage to the aircraft system or reservoir may result if either return line valve is closed while the machine is running.

5.4 START UP PROCEDURES

5.4.1 Pump Rotation Check Procedure (First Time Use or Change of Electrical Supply Only)

Phase Monitor (Options H – J Only): Check that the phase monitor light on the instrument panel is not illuminated. If the light is illuminated, change any two of the three input leads at the plug. Once the phase monitor light is not illuminated with power attached, check for proper motor rotation.

To check rotation (with or without Phase Monitor):

- Close the fluid pressure ball valve(s) at the rear of the HPU. Reference **5.3.4** for location of ball valve.
- Open the bypass valve on the instrument panel fully counter-clockwise.
- Set the flow control on the pump to maximum flow (fully counter-clockwise).
- Place the reservoir selector valve in HPU Reservoir position.
- Remove the pump/motor coupling guard. Reference Pump/Motor Coupling Access. figure

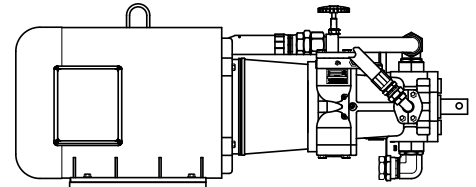

Pump/Motor Coupling Access



Rotating Parts! Keep hands, feet, hair, and clothing away from all moving parts to prevent injury. Never operate the HPU with covers, shrouds, or guards removed.



Electrical Shock! Never touch electrical wires or components while the HPU is attached to the power source. They can be sources of electrical shock. Do not operate HPU with cabinet panels removed.

- Verify that the unit has been prepared for use by connecting electrical leads and servicing the reservoir. (Reference 3.0 Preparation Prior to First Use)
- Keeping hands clear of the pump/motor coupling area, momentarily press the start button and immediately press the stop button.
- Observe direction of rotation of the pump/motor coupling. When the Operator is facing the front panel, the pump/motor coupling should be rotating in a clockwise direction.
- If the pump/motor coupling is rotating in a counter-clockwise direction, change any two of the three leads at the plug. Observe direction of rotation to verify that pump/motor is rotating in a clockwise direction.
- Replace the pump/motor coupling guard.

5.4.2 Initial Start Up of the HPU

- Unit must be prepared per **4.0 Preparation Prior to First Use** and **6.4.1 Pump Rotation Check Procedure (First Time Use or Change of Electrical Supply Only)** before starting the HPU.
- Operator must be familiar with this manual and be properly trained prior to starting the HPU.
- Close the fluid pressure ball valve(s) at the rear of the HPU. Reference **5.3.4** for location of ball valve.
- Open the bypass valve on the instrument panel fully counter-clockwise.
- Set the flow control on the pump to maximum flow (fully counter-clockwise).
- Place the reservoir selector valve in HPU Reservoir position.
- Press the start switch; the flowmeter should show full flow immediately. If no flow displays on the flow meter, press the stop switch immediately and reference **8.2 No Flow** in Trouble Shooting section.
- Adjust the flow down to approximately 10–20 gpm (38–76 lpm).
- Close the bypass valve, adjust the pressure control until 3,000 psi (206.84 bar) is displayed on the pressure gauge. (If no pressure displays on the system pressure gauge after adjusting the pressure control, reference **Trouble Shooting 8.4 No Pressure or Reduced Pressure**).
- Open the bypass valve; press the stop switch

NOTE: Maintenance and Trouble Shooting are to be performed by a skilled and trained technician.

5.5 PRELIMINARY ADJUSTMENTS FOR OPERATION

The following are basic to the operation of the HPU and should be thoroughly understood. The pressure and flow controls have lock nuts to prevent rotation of the control shaft during operation. These nuts should be moved away from the pump during adjustment of flow or pressure in order to eliminate binding of the control shafts.

5.5.1 Flow Control Adjustment

- Open bypass valve.
- Select "Hydraulic Power Unit" position with reservoir selector valve.
- Start HPU.
- Adjust flow control on pump for maximum desired flow. Observing the flowmeter, read flow in gallons (liters) per minute directly from flowmeter. Be sure the control shaft lock nut is loose during adjustment. Tighten after adjustment to maintain setting.

5.5.2 Pressure Control Adjustment

- a. Open bypass valve.
- b. Select "Hydraulic Power Unit" position with reservoir selector valve.
- c. Start HPU.
- d. Close bypass valve.
- e. Adjust pressure control for desired pressure; observing the system pressure gauge, read in psi (bars). Be sure the control shaft lock nut is loose during adjustment. Tighten after adjustment to maintain setting.

NOTE: Once the flow and pressure controls have been adjusted, it is not necessary to change these settings after each operation unless desired.

5.5.3 Reservoir Selector Valve Operation

Operation of the reservoir selector valve allows the operator to select either the aircraft reservoir (closed loop) or the HPU reservoir (open loop).



CAUTION!

The reservoir selector valve should only be operated when the HPU is not running. The operation of the reservoir selector valve should be done prior to starting the HPU.

a. Aircraft Reservoir Position (Closed Loop)

In this position, the HPU is dependent on the aircraft reservoir and system for an adequate supply of fluid. Cavitation, due to an inadequate fluid supply from the aircraft, may be indicated by erratic fluctuation of the system pressure gauge or flowmeter. At times, the aircraft fluid supply will be restricted due to small return oil lines in the aircraft. If this is a problem, decrease the flow control setting until the cavitation is eliminated.

b. HPU Reservoir Position (Open Loop)

In this position, the HPU reservoir supplies fluid to the pump and accepts return fluid from the aircraft. It is desirable to operate the HPU in this mode since it eliminates any possibility of cavitation.

Since the HPU reservoir is vented to atmosphere and the aircraft is at a higher level, it is normal for the aircraft reservoir to drain into the HPU reservoir. It is, therefore, necessary to be sure that sufficient room is available in the HPU reservoir to accommodate the additional fluid.



CAUTION!

The aircraft system reservoir must be serviced after completion of operational testing.

In the "HPU Reservoir" position, faster landing gear swings are usually possible since there is no restriction to flow at the pump inlet.

5.5.4 Bypass Valve Operation

The bypass valve is used for unloading the pump. The valve should be either in the fully open or fully closed position only. Do not operate the valve in a partially open position.

a. Start Up Operation

The bypass valve must be opened prior to starting the HPU in order to allow the motor to start under a no load condition and not pressurize the aircraft hydraulic system.

b. Shut Down Operation:

Prior to shutdown, the bypass valve must be opened to bleed off any residual system pressure.



CAUTION!

Excessive heat, which could damage machine components, will be generated if the bypass valve is partially open or is used for regulating flow or pressure.

- Use the flow and pressure controls for regulation.
- Use the bypass valve for unloading the system only.

5.5.5 RETURN BACK-PRESSURE VALVE OPERATION

The **backpressure** valve is used for maintaining a preset (adjustable) pressure in the return line from the aircraft. The **backpressure bypass** valve allows fluid to flow directly from the aircraft to the HPU reservoir, bypassing the backpressure valve. The **return line pressure gauge** displays the pressure in the return line from the aircraft (See figure 6.3.4 on page 11). The **backpressure bypass** valve can also be used to slowly relieve the backpressure in the return line.

Return Backpressure Setting:

1. Disconnect electrical power from the HPU.
2. Connect the pressure and return hoses together (matching systems).
3. Open the pressure and return system **ball valves**.
4. Connect electrical power to the HPU.
5. Open the system bypass valve, start the HPU, set the flow to one (5) gpm.
6. With the HPU running, close the **system bypass** valve and the **return bypass** valve.
7. While observing the return line **pressure gauge**, adjust the **return backpressure** valve to the desired pressure by turning the knob clockwise to increase pressure; counterclockwise to decrease pressure.
8. Open the **system bypass** valve.
9. Shut off the HPU.
10. Disconnect electrical power from the HPU.
11. Return the hoses to the original condition.

NOTE: Once the back pressure valve has been adjusted, it is not necessary to change the setting after each operation.

5.5.6 RETURN SIGHTGAUGE

The **return sightgauge** is used for monitoring the return fluid from the aircraft. This gauge displays the fluid in return line, allowing a visual check for air in the aircraft hydraulic system (See figure 6.3.4). A light behind the sightgauge is supplied for easy viewing in poor lighting conditions (See figure 6.3.2).

5.6 BLEEDING AIR FROM SYSTEM

Rapid fluctuations of the pressure gauge and flow meter are indications of cavitation or entrapped air in the hydraulic lines and/or components. Air may enter the system when:

- Operating the unit with insufficient oil in the reservoir.
- Changing a component on the aircraft.
- Changing hose connections and/or couplings.

5.6.1 To Easily Purge the Unit of Air

- a. Fill reservoir to recommended level.
- b. Open bypass valve.
- c. Place reservoir selector valve in "Hydraulic Power Unit" position.
- d. Start unit and adjust flow control to maximum position.

NOTE: If fluid is not flowing, shut off HPU and reference 8.2 No Flow in Trouble Shooting section

- e. Run unit for five (5) minutes and shut off.
- f. If additional bleeding is required, connect the pressure and return hoses together and open all pressure and return ball valves at the rear of the HPU. Start the HPU and slowly close the bypass valve (system pressure should remain under 200 psi (approximately 14 bar). Allow fluid to flow at full flow for five (5) minutes, then shut the HPU off.



WARNING!

Failure to open the return ball valves will cause hose or valve rupture. Property damage and personal injury can result.

5.7 SPLIT SYSTEM OPERATION

The split system option allows control of fluid flow to aircraft with two hydraulic systems. The systems consist of two sets of hoses and valves located in the pressure and return systems. The valves are mounted on the rear of the hydraulic power unit and are of the 90° ball type. The valves are open when the operating handle is in line with the valve.

Although both systems may be operated simultaneously, usually only one system is required at any one time. If both valve sets are open simultaneously, the pump output will be divided between the two systems. Also, cross flow between aircraft reservoirs may occur if a reservoir level or pressure differential exists. Select valve positions prior to starting machine.

5.7.1 To Operate the Split System

- a. Before starting machine, open pressure and return valves of the same system.



WARNING!

Ensure pressure and return hoses of the same system are paired and used together.

- b. After completing tests on one system, shut the machine off before selecting the second system.



WARNING!

NEVER open or close split system valves without shutting off the Hydraulic Power Unit. Damage to the aircraft system or reservoir may result if either return line valve is closed while the machine is running.

5.8 HAND PUMP OPERATION (*Option M*)

The Hand Pump Option allows for filling the reservoir (low pressure) or static testing of components or system (high pressure). The hand pump circuit is separate from the main hydraulic system; a separate filter and hose are attached to the back panel of the HPU.

5.8.1 To Operate the Hand Pump

- a. Remove the pump handle from inside the front access door. (Reference **5.3.6 – Hand Pump Controls**)
- b. Insert the end of the pump handle through the front panel opening into the hand pump relief screw.
- c. Turn the pump handle clockwise to close the relief screw.
- d. Insert the pump handle onto the hand pump arm through the front panel slot.
- e. Pump the handle using an up and down motion. Observe the hand pump system pressure on the hydraulic control panel (**Figure 6.3.3 Hydraulic Control Panel**). The pump is an automatic two stage pump. 500 psi (34.47 bar) can be produced with high fluid flow and 5,000 psi (344.74 bar) can be produced with low fluid flow.
- f. Turning the relief screw in a counter-clockwise direction releases hydraulic pressure in the hand pump system.



Pressurized Fluid! Before disconnecting the hand pump pressure hose, ALWAYS open the relief screw valve to relieve any residual pressure in the hydraulic system.

5.9 SAMPLE VALVE

A sample valve is provided on the rear of the unit to obtain a fluid sample for analysis or inspection. In order to obtain a representative fluid sample, it is suggested that ANSI/B93.19M-1972 (R1993) be followed. *Reference Appendix VIII.*



Pressurized Fluid! Before servicing the HPU or equipment, ALWAYS open the bypass valve to relieve any residual pressure in the hydraulic system.

5.10 EMERGENCY SHUT DOWN PROCEDURE

In the event an emergency shut down is necessary, press the emergency stop switch located on the electrical panel. (Reference **5.3.2 – Electrical Control Panel**) Open the bypass valve to remove any system pressure.

5.11 DESCRIPTION OF ALARM SYSTEMS

Reference **5.3.2 – Electrical Control Panel**

5.11.1 High Fluid Temperature Indicator

The indicator light for high fluid temperature is an active light which will illuminate when the return fluid temperature is 170° F (77° C) or above. The HPU will shut down if the light is illuminated. The HPU can be re-started when the fluid has cooled sufficiently and the light has shut off.

If the high temperature light is illuminated reference section **8.0 Trouble Shooting**.

5.11.2 Voltage/Phase Monitor Indicator

The indicator light for the voltage/phase monitor is an active light which will illuminate if there is a problem with the incoming electrical power source. The HPU will shut down if the light is illuminated.

If the voltage/phase monitor light is illuminated, reference section 8.0 Trouble Shooting.

5.11.3 High and Low Reservoir Level Indicator (*Option L*)

The indicator lights for high and low reservoir level are active lights which will illuminate when the reservoir fluid level is either above the maximum level or below the minimum level. The HPU will shut down if either of the lights are illuminated.

If the light on either of the reservoir level indicator lights, restore the fluid level in the reservoir to a normal operating range.

5.11.4 Clogged Filter Indicator Light

The indicator light for the clogged filter is a passive light which will illuminate if the pressure filter element becomes clogged or is in need of replacement. The HPU will not shut down if the light is illuminated.

If the clogged filter indicator light is illuminated, the pressure filter element requires changing. Reference 9.5.1 Pressure Filter Element) for maintenance procedure. Pressing the clogging filter indicator light will reset the light and the light will turn off.

NOTE: Maintenance and Trouble Shooting are to be performed by a skilled and trained technician.

5.12 INFREQUENT HPU USE

If the unit is not used frequently Tronair recommends operating the unit monthly. Operating regularly assures that the seals are kept lubricated, eliminates air pockets in the system, reduces moisture in the fluid and helps extend the hose life.

5.12.1 Infrequent HPU Use Start Up Procedure

1. Assure that the HPU reservoir is filled between the minimum and maximum level
2. Connect the unit to a proper electrical power source
3. If unit is equipped with a run around kit, connect the pressure and return hoses together
4. Place the reservoir selector valve in "HPU Reservoir" position
5. Open the return ball valves on the back of the unit
6. Pressure ball valves
 - a. If unit **IS** equipped with a runaround kit **ensure the hoses are connected to each other**, open the pressure ball valves on the back of the unit
 - b. If the hoses **are not connected to each other**, close the pressure ball valves on the back of the unit
7. Verify the return ball valves on the back of the unit are open
8. Fully open the bypass valve
9. Adjust the pressure control to the minimum setting (CCW)
10. Start the unit and verify the flow is above "0" on the flowmeter
 - a. If flow is present: adjust the flow control to increase flow (CW)
 - b. If no flow is immediately present: turn unit off, verify the motor rotation (see 3.3 Connecting Electrical Leads), correct rotation if necessary
11. Set flow to ½ the maximum flow capacity of the unit. You may need to increase the pressure adjustment to achieve flow.
12. Bypass valve
 - a. If unit **IS** equipped with a runaround kit **ensure the hoses are connected to each other**, fully close the bypass valve
 - b. If the hoses **are not connected to each other**, leave the bypass valve fully open
13. Operate the unit for 15-30 minutes in this condition. Fluid temperature should reach 100°-130° F (37.8°-54.4° C)
14. At the completion of the 15-30 minute circulation run, open the bypass valve and shut off the unit
15. Remove the electric power
16. Place the selector valve in the Aircraft Reservoir position
17. Close the pressure and return ball valves on the back of the unit

6.0 PACKAGING AND STORAGE

6.1 PACKAGING REQUIREMENTS

- a. Drain hydraulic fluid until level is below the minimum fluid level indicator.
- b. Block up the unit on a pallet so the wheels are not touching the pallet or shipping container.
- c. Plug all hose ends.
- d. Strap unit to pallet or shipping container using the tie down rings located on the frame bottom.

NOTE: Use at least four (4) straps with a minimum 8,000 lb (3,629 kg) capacity each.

6.2 HANDLING

The unit is designed to be moved by hand using the handles located on the front of the unit. The unit can be lifted by means of a fork truck from the center of the machine. Lifting must be from the motor side of the unit only.

NOTE: Be sure the forks are long enough to reach the frame cross members for stability during lifting. Spread the forks to their maximum width for stability. Reference Figure HPU on Forklift.

6.3 PACKAGING PROTECTION

No special packaging material for cushioning or suspension is required.

6.4 LABELING OF PACKAGING

Packaging should be labeled as follows:

**DO NOT DROP
THIS SIDE UP
DO NOT STACK** ↑

6.5 STORAGE COMPATIBILITY

No special considerations for short term storage (less than three months).

6.6 STORAGE ENVIRONMENT

Cover HPU with a suitable, non-abrasive tarp if storing outside. For storage periods greater than three months, drain hydraulic fluid from all hoses and the reservoir. Cover unit to protect outside surface.

If storing outside, protect unit from freezing water, sand, dirt, and direct sunlight. A cover is highly recommended.

6.7 STORAGE SPACE AND HANDLING FACILITIES

Weight (Dry) 6,000 lbs (2,722 kg)
 Width 68-5/8 in (35 cm) Add 6.0 in (15.2 cm) for Split System
 Height 62-7/8 in (25 cm)
 Depth 101-13/16 in (40 cm) Add 11 in (25 cm) for trailer option

7.0 TRANSPORTATION

1. Do not stack Hydraulic Power Units.
2. The unit can be lifted by means of a fork truck from the motor side center of the HPU.

NOTE: Be sure the forks are long enough to reach frame cross members for stability during lifting. Spread the forks to their maximum width for stability. Reference figure HPU on Forklift.

Weight (Dry) 6,000 lbs (2,722 kg) *Estimated*

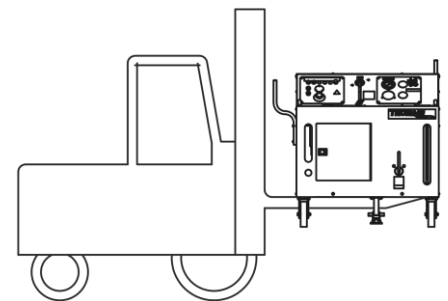

HPU on Forklift

8.0 TROUBLE SHOOTING

The following is a guide to solutions of common problems associated with the HPU. See related Appendices for Hydraulic and Electrical Schematics.

If the problem is not resolved using the trouble shooting information, call the manufacturer for Technical Assistance (See Section **1.3 Manufacturer**).

NOTE: Maintenance and Trouble Shooting are to be performed by a skilled and trained Technician.

8.1 HPU WILL NOT START

Possible Cause	Solution
Supply power off	Check incoming power and restore power. Check across-the-line voltage on all three phase legs
Supply power fuses are blown/ circuit breakers tripped	Check and replace. Check across-the-line voltage on all three phase legs
Control Transformer fuses blown	Check and replace
Supply power phase or voltage incorrect (Phase/Voltage Monitor Option G – J only)	Voltage/Phase Monitor Indicator light will be illuminated Refer to Section 3.3 Connecting Electrical Leads
Reservoir fluid level is too high or too low (Electric Reservoir Level Option L only)	One reservoir level indicator light (Low or High) will be illuminated. Fill the reservoir above the Minimum Fluid Level arrow to extinguish the Low Level light. Drain fluid below the Maximum Fluid Level arrow to extinguish the High Level light
High return fluid temperature (Electric Over-Temperature Option S only)	High Fluid Temperature indicator light will be illuminated. Allow the hydraulic fluid to cool until the light goes out. Refer to Section 8.5 for over-heated causes
Motor has tripped thermal overload device	Allow the motor to cool. The thermal overload device (motor starter) will reset automatically after sufficient cooling. The tripped condition is usually caused by loading the motor beyond its rated capacity; however, any condition (such as unbalanced voltage) that causes an increase in amperage can result in a tripped condition

NOTE: Using the bypass valve to meter flow or pressure will increase the motor load and may cause the thermal overload device to trip. Refer to section 6.5.4 Bypass Valve Operation for proper use of the bypass valve.

8.2 NO FLOW

Possible Cause	Solution
Motor turning in wrong direction	See Section 3.3 Connecting Electrical Leads
Flow control set too low	Increase flow setting
Fluid level in reservoir too low	Service the HPU reservoir
Air in pump inlet lines	Disconnect the HPU from the aircraft. Fill the HPU reservoir to a level above the pump inlet port. Set the reservoir selector valve to the HPU Reservoir position. Fully open the Bypass Valve. Close the Pressure and Return ball valves at the rear of the unit. Adjust the pump flow to maximum and "bump" the start and stop switches to "jog" the motor. Flow should be indicated at the Flowmeter on first or second "jog"

NOTE: Under some conditions where a large amount of air has entered the system, the pump may not be able to draw an initial prime. If this occurs, loosen the inlet hose near the pump and allow air to escape. Re-tighten the hose when fluid appears.

Possible Cause	Solution
Motor is turning but pump is not	Check pump and motor couplings to ensure they are tight
Flow path does not exist	A flow path (such as a moving actuator or an open circuit) must exist for flow to be present. When system pressure exceeds the compensator control setting, or when the system no longer requires flow, the control de-strokes the pump while maintaining the preset pressure

8.3 REDUCED FLOW

Possible Cause	Solution
Flow control set too low	Increase flow setting.
Pressure adjustment is set too low	Slightly increase pressure setting.
Pressure compensator control is reducing pump output	When system pressure exceeds the compensator control setting, or when the system no longer requires flow, the control de-strokes the pump while maintaining the preset pressure.
Pump inlet is not receiving enough fluid (cavitation)	Follow the procedure for “Air in pump inlet lines” in Section 8.2.
Motor is “Single Phasing”	Motor is not getting power on all three phase legs. Check across-the-line voltage on all three phase legs.
Supply voltage is 50 Hz	Pumps used on 50 Hz units will flow at only 83% of the pump nameplate rating. An HPU designed to run on 50 Hz will supply flow as stated in the specifications for that unit.

8.4 NO PRESSURE or REDUCED PRESSURE

Possible Cause	Solution
Pressure adjustment is set too low	Increase pressure adjustment.
Motor is “Single Phasing”	Motor is not getting power on all three phase legs. Check across-the-line voltage on all three phase legs.
Pump inlet is not receiving enough fluid (cavitation)	Follow the procedure for “Air in pump inlet lines” in Section 8.2.
Flow path is open	Pressure is resistance to flow. The HPU will reach full pressure as flow paths (such as moving actuators and open valves) are closed.

8.5 FLUID OVERHEATS

Possible Cause	Solution
Fan is not functioning properly	Check the cooler fan output. Forced air should be easily detected at the right hand side of the HPU. Check the fuses for the fan motor (See Appendices – Electrical Schematic INS-2016).
Bypass valve or rear ball valve is being used in a partially closed position	The bypass valve and all ball valves must be used in a fully open or fully closed position. These valves are not intended for metering flow. All flow adjustments must be made using the pump flow control.

8.6 HAND PUMP (*Option M*) IS NOT PUMPING FLUID

Possible Cause	Solution
Release screw is open	Use the slotted end of the pump handle to close the release screw located at the base of the pump.
Ball valve is closed	Open the ball valve for the pump inlet line located at the bottom of the reservoir.
Pump piston is filled with air	If the pump is not primed after several strokes, remove the bleed screw from the top of the pump piston (See Section 9.13.9.a – <i>Pump Diagram</i>). Slowly stroke the pump until fluid is present at the bleed screw. Replace the bleed screw.

9.0 MAINTENANCE

If the unit is not used frequently Tronair recommends operating the unit monthly. Operating regularly assures that the seals are kept lubricated, eliminates air pockets in the system, reduces moisture in the fluid and helps extend the hose life. If the unit is not used frequently see 5.12 Infrequent Use Procedure.

9.1 GENERAL

Periodically inspect the HPU for loose fasteners, hose fittings, damaged hoses, and worn electrical cables. Make repairs as needed for safe operation.

Reference Sections **9.2 – 9.15** for Parts Lists, Descriptions and Illustrations.

9.2 ELECTRIC MOTOR

The Electric Motor is pre-greased by the manufacturer. Periodic greasing is necessary on a frequently used HPU. **Reference Appendix – Lincoln Motor Manual** for details.

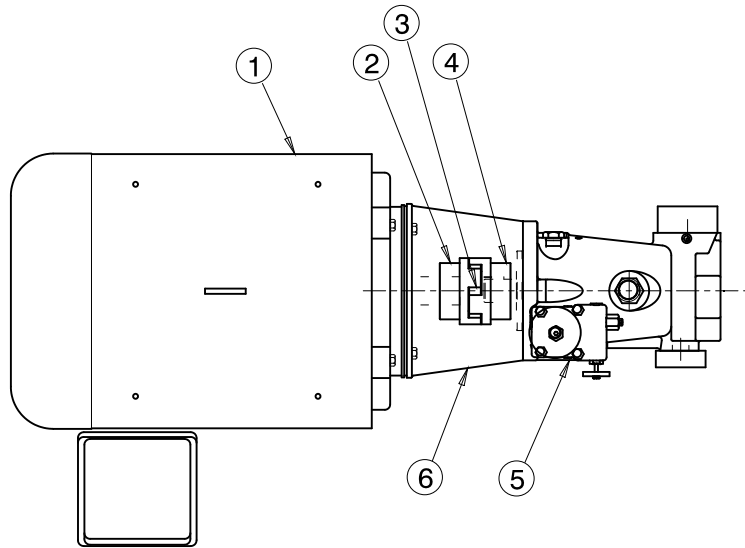

Parts List

Item	Part Number	Description	Qty
1	Reference table below	Electric Motor	1
2	H-2552-30	Coupling (Motor Half)	1
3	H-2551	Spider (Hytrel)	1
4	H-3245	Coupling (Pump Half)	1
5	Reference 10.3 and 10.3.1	Motor Driven Hydraulic Pump	1
6	HC-1427-08	Pump/Motor Adapter	1

60 Hz Applications	
Voltage	Part Number
380	EC-1224-17
460	EC-1224-17
575	EC-1224-18

50 Hz Applications	
Voltage	Part Number
380	EC-1224-17
415	EC-1224-17
440	EC-1224-17

9.3 MOTOR DRIVEN HYDRAULIC PUMP

The hydraulic pump does not require regular maintenance. Under normal operating conditions, the pump will perform for thousands of hours of use without rebuilding. See **Appendix VI – Denison PV Series Pumps** for further details.

9.3.1 Motor Driven Hydraulic Pump Replacement Parts

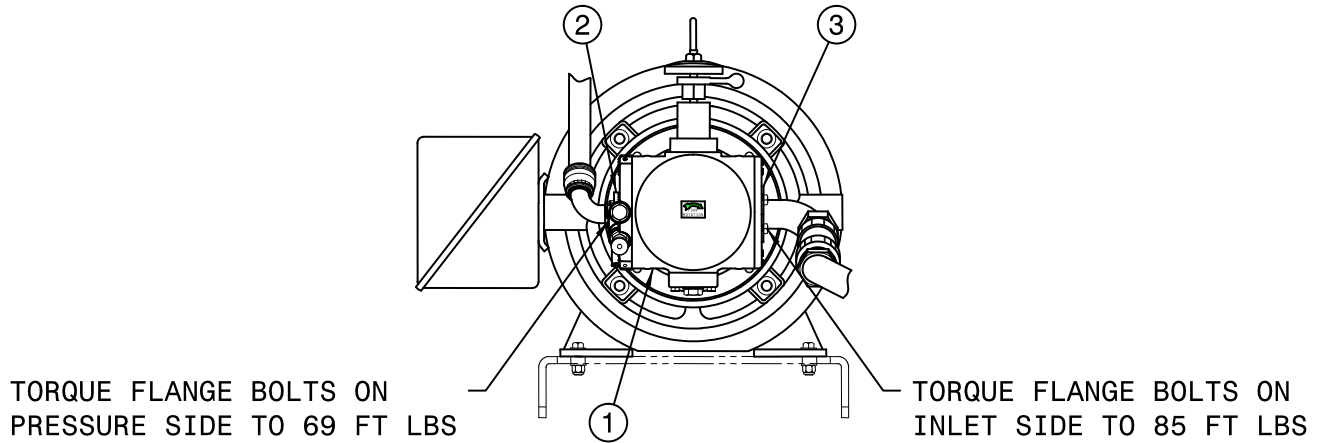

Parts List

Model Number	Fluid Type
5813	MIL-PRF-5606
5823	MIL-PRF-83282
5833	Aviation Phosphate Ester, Type IV and V
5834	MIL-PRF-87257

	5813, 5823, 5843	5833		
Item	Part Number	Part Number	Description	Qty
◆ 1	◆ HC-2956	◆ HC-2720-01	ASSEMBLY, HYDRAULIC PUMP	1
2	HC-2664-03-S-V	HC-2664-03-S-E	KIT, FLANGE (<i>PRESSURE SIDE</i>)	1
3	N-3191-07	N-2674-07	KIT, FLANGE (<i>INLET SIDE</i>)	1
N/S	N-2007-29-S-V	N-2007-29-S-E	FITTING, CONNECTOR (<i>CASE DRAIN PORT</i>)	1
N/S	N-2924	N-2924	CONNECTOR, IN-LINE ORIFICE	

◆ Refer to section 9.14 for listing of Replacement Labels.

9.3.2 Motor Driven Hydraulic Pump Replacement Kits List

Fluid Type: Aviation Phosphate Ester, Type IV, V

Part Number	Description
*	Kit, Shaft and Bearing Assembly
*	Kit, Shaft Seal

* Call Tronair for Details

9.4 HYDRAULIC FLUID

Any time an unusual color, smell or visual indicator is noticed with the hydraulic fluid, a sample analysis should be performed to determine the condition of the fluid. (See 6.9 – Sample Valve Operation)

Refer to the manufacturer of the specific fluid for your unit to obtain additional information:

Model Number	Fluid Type
5813	MIL-PRF-5606
5823	MIL-PRF-83282
5833	Aviation Phosphate Ester, Type IV
5834	MIL-PRF-87257

9.5 FILTERS

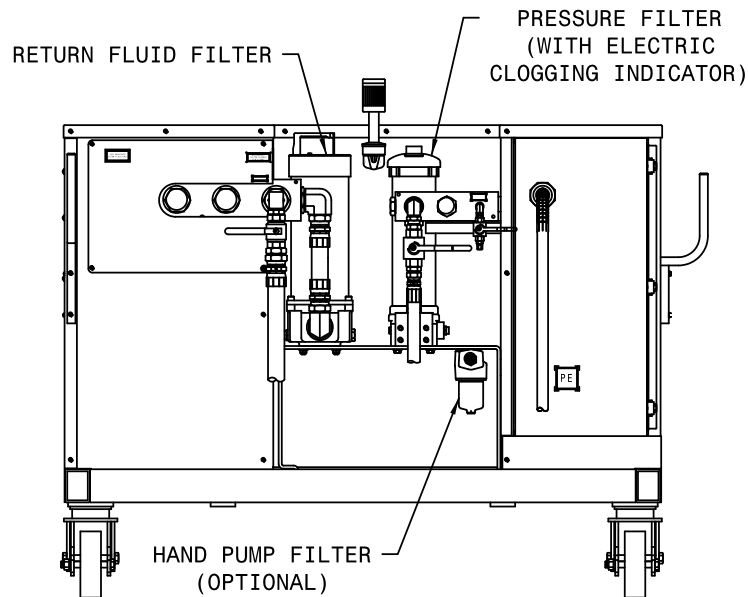

9.5.1 Pressure Filter Element

Replace the filter element any time the clogged filter indicator light is triggered.
Replace the filter element annually to ensure proper cleanliness of the hydraulic system. This is a minimum requirement.

Standard filter changes depend on how frequently the HPU is used and the cleanliness of the fluid, along with the environment to which the HPU is exposed. Periodic fluid analysis is recommended to properly determine the optimum frequency of filter element changes.

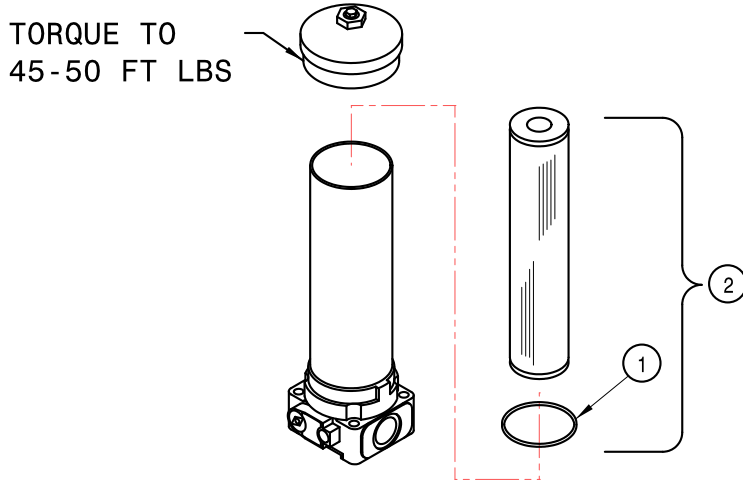

Parts List

Model Number	Fluid Type
5813	MIL-PRF-5606
5823	MIL-PRF-83282
5833	Aviation Phosphate Ester, Type IV and V
5834	MIL-PRF-87257

Item	5813, 5823, 5843		5833	Description	Qty
	Part Number	Part Number	Part Number		
1	HC-2007-246	HC-2006-246		O-RING	1
2	K-5033	K-3588		KIT, FILTER ELEMENT	1

9.5.2 Return Filter Element

Replace the return filter element at the same time the pressure filter element is being replaced.

TO ACCESS FILTER ELEMENT,
REMOVE TOP OF FILTER
BODY. HANDLE TORQUE
IS TO BE HAND TIGHT.

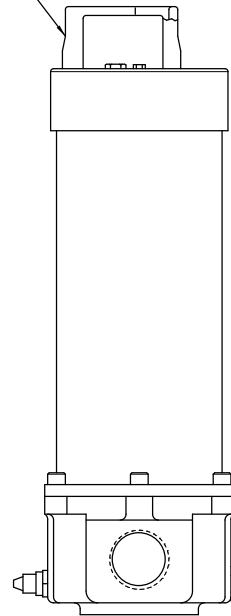

Parts List

Model Number	Fluid Type
5813	MIL-PRF-5606
5823	MIL-PRF-83282
5833	Aviation Phosphate Ester, Type IV and V
5834	MIL-PRF-87257

	5813, 5823, 5843	5833		
Item	Part Number	Part Number	Description	Qty
1	N72257	HC-2006-257	O-RING	1
2	◆ K-5619	◆ K-3587	KIT, REPLACEMENT FILTER ELEMENT	1

- ◆ K-5619 – N72257 O-ring is included in Kit
- ◆ K-3587 - HC-2006-257 O-ring is included in Kit

9.5.3 Hand Pump (Option M) Filter Element

Replacement of the hand pump filter element is dictated by frequency of use and the cleanliness of the fluid, along with the environment to which the HPU is exposed. Changing the hand pump filter element at the same time as the pressure filter element will ensure a regular maintenance schedule.

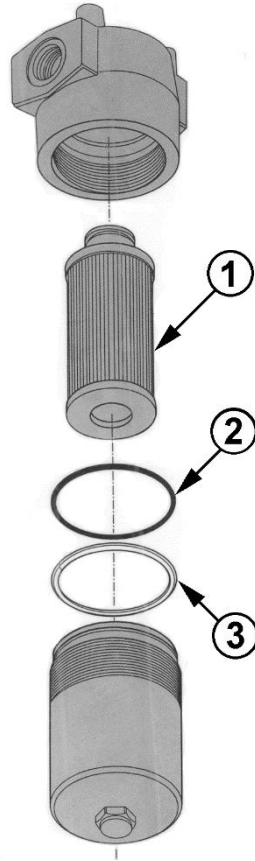

Parts List

Model Number	Fluid Type
5813	MIL-PRF-5606
5823	MIL-PRF-83282
5833	Aviation Phosphate Ester, Type IV and V
5834	MIL-PRF-87257

	5813, 5823, 5843	5833		
Item	Part Number	Part Number	Description	Qty
2 & 3	K-3832	K-3797	O-RING AND BACKUP RING	1
1 - 3	K-3831	K-3752	KIT, REPLACEMENT FILTER ELEMENT	1

9.5.4 Desiccant Air Filter

Replace the desiccant/air filter whenever the material inside the element is pink or reddish in color (see Element Label for details).

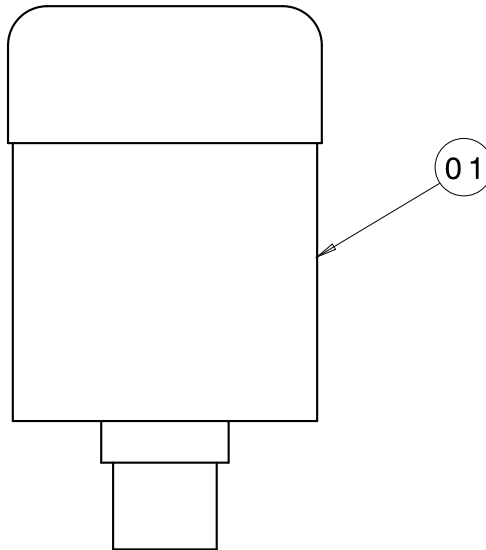
**Parts List**

Item	Part Number	Description	Qty
1	HC-1763	Filter Element	1

9.5.5 Pressure Filter Assembly with Electric Filter Clogging Indicator

The Electric Filter Clogging Indicator does not require regular general maintenance. The panel light will illuminate when the clogging indicator senses a 50 psi differential pressure across the filter element. Installing a new filter element will eliminate the clogged condition. Pushing the illuminated button will reset the indicator light.

NOTE: Higher flow rates will result in higher differential pressures. (Example: The clogging indicator may sense a 50 psi differential pressure at a flow rate of 34 gpm but not show a clogged condition when the flow rate is reduced to 10 gpm.)

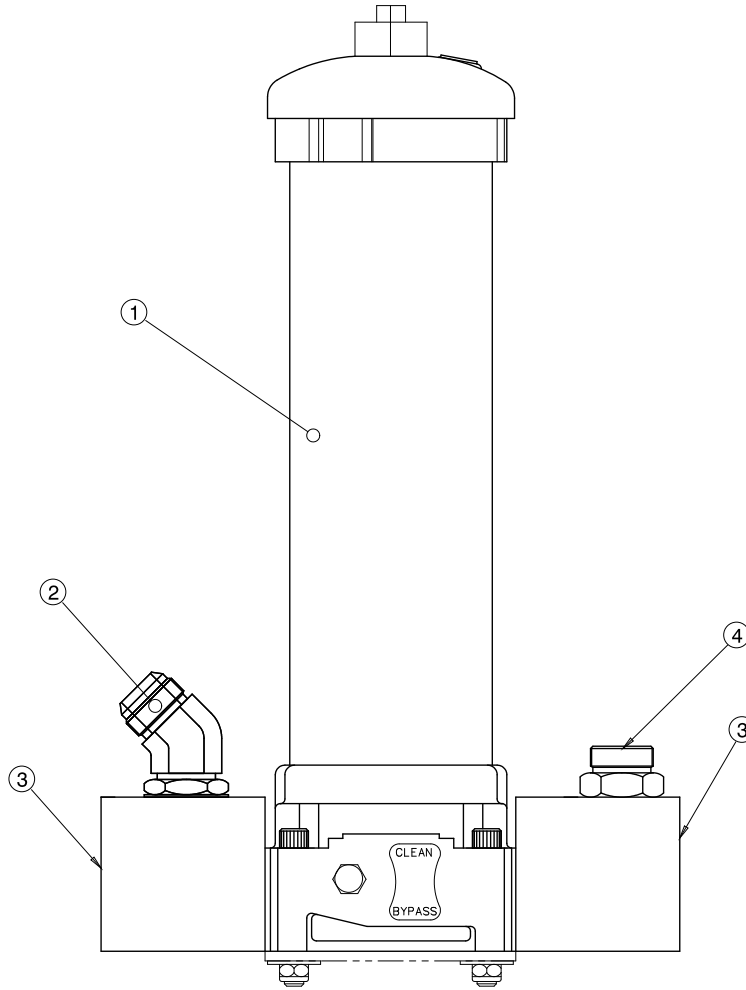

Parts List

Model Number	Fluid Type
5813	MIL-PRF-5606
5823	MIL-PRF-83282
5833	Aviation Phosphate Ester, Type IV and V
5834	MIL-PRF-87257

Item	5813, 5823, 5843	5833	Description	Qty
	Part Number	Part Number		
1	HC-2659	HC-2053	FILTER, PRESSURE	1
2	N-2974-S-V	N-2974-S-E	ELBOW, 45° STRAIGHT THREAD	1
3	HC-2106	HC-2106	FLANGE, ELBOW	1

9.5.6 Return Filter Assembly

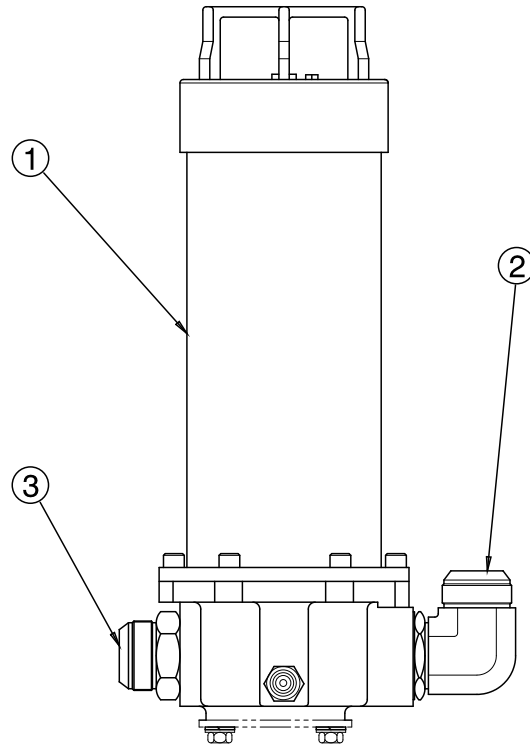

Parts List

Model Number	Fluid Type
5813	MIL-PRF-5606
5823	MIL-PRF-83282
5833	Aviation Phosphate Ester, Type IV and V
5834	MIL-PRF-87257

Item	5813, 5823, 5843	5833	Description	Qty
	Part Number	Part Number		
1	HC-2661	HC-2052	FILTER, RETURN	1
2	N-2001-33-S-V	N-2001-33-S-E	ELBOW, STRAIGHT THREAD	1
3	N-2007-33-S-V	N-2007-33-S-E	CONNECTOR, #32 STRAIGHT THREAD	1

This page left blank intentionally.

9.6 HYDRAULIC HOSES

Hoses used on the HPU must be periodically inspected for damage, blisters, leaks, or hose end problems. Any damaged or defective hose should be replaced as soon as possible.

Hoses used on Aviation Phosphate Ester, Type IV units have a shorter useful life than hoses used on Mineral Base units. Surface moisture is normal with Aviation Phosphate Ester, Type IV hoses as long as the fluid does not form into drops.

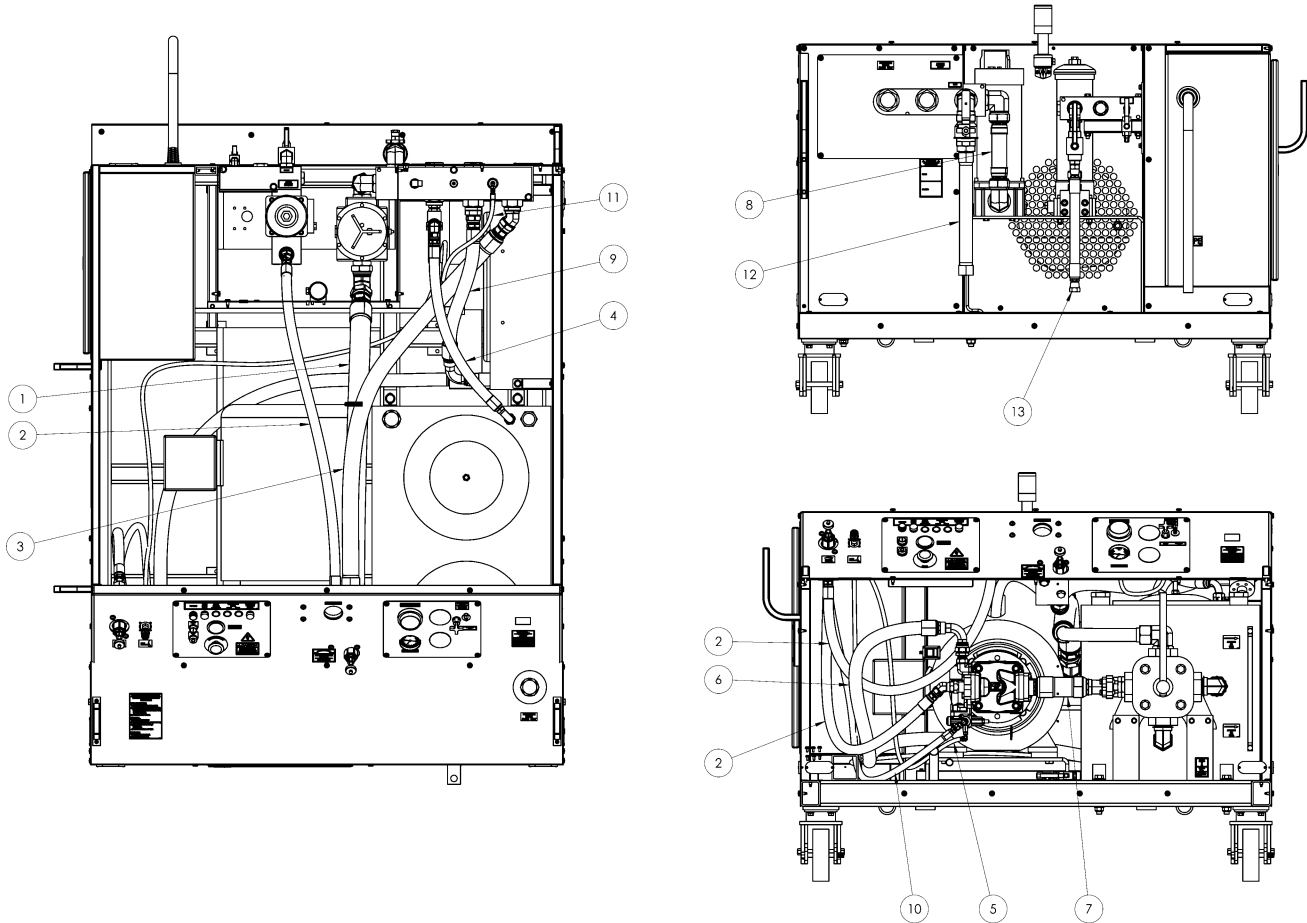

9.6 HYDRAULIC HOSES (continued)

Parts List

Model Number	Fluid Type
5813	MIL-PRF-5606
5823	MIL-PRF-83282
5833	Aviation Phosphate Ester, Type IV and V
5834	MIL-PRF-87257

Item	5813, 5823, 5843	5833	Description	Qty
	Part Number	Part Number		
1	TF-1039-32-59.0	TF-1041-18*59.0	ASSEMBLY, HOSE #32	1
2	TF-1117-37-57.5	TF-1117-37-57.5	ASSEMBLY, HOSE #16	3
3	TF-1039-04-70.5	TF-1041-04*70.5	ASSEMBLY, HOSE #24	1
4	TF-1039-09-37.5	TF-1041-16*37.5	ASSEMBLY, HOSE #16	1
5	TF-1038-14-66.0	TF-1041-05*66.0	ASSEMBLY, HOSE #4	1
6	TF-1039-33-110	TF-1041-32*110	ASSEMBLY, HOSE #20	1
7	TF-1196-11-12.5	TF-1196-11-12.5	ASSEMBLY, HOSE #32	1
8	TF-1039-32-11.7	TF-1041-18*11.7	ASSEMBLY, HOSE #32	1
9	TF-1039-33-29.0	TF-1041-54*29.0	ASSEMBLY, HOSE #20	1
10	TF-1195-02-75.0	TF-1195-02-75.0	ASSEMBLY, HOSE #8	1
11	TF-1038-14-180	TF-1041-05-180	ASSEMBLY, HOSE #4	1
12	TF-1038-40*300	TF-1040-05*300	EXTERNAL PRESSURE HOSE	1
13	TF-1038-04*300	TF-1041-04*300	EXTERNAL RETURN HOSE	1
14	TF-1038-16-24.0	TF-1040-42-24.0	ASSEMBLY, HOSE #4	1
15	TF-1038-16-32.0	TF-1040-42-32.0	ASSEMBLY, HOSE #4	1

9.7 INSTRUMENT PANEL

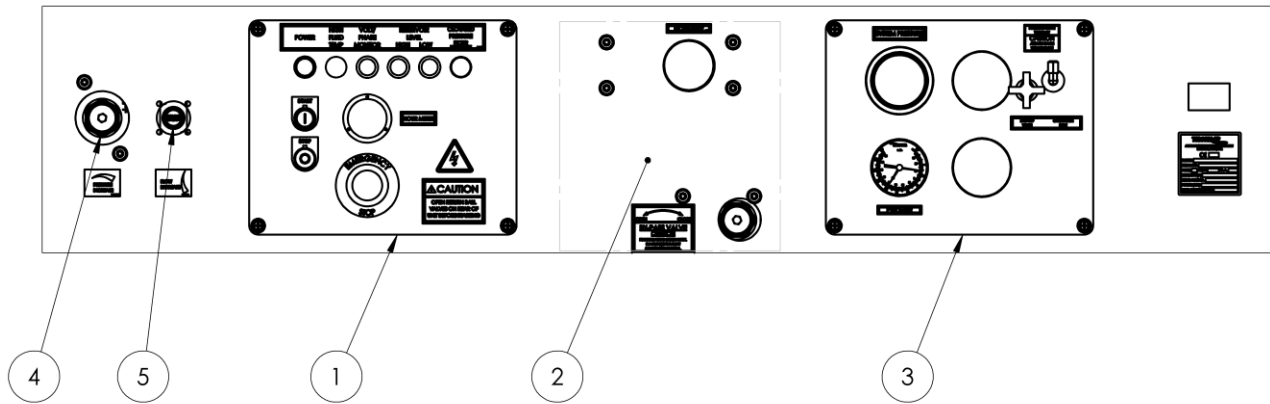

Parts List

Model Number	Fluid Type
5813	MIL-PRF-5606
5823	MIL-PRF-83282
5833	Aviation Phosphate Ester, Type IV and V
5834	MIL-PRF-87257

Item	5813, 5823, 5843	5833	Description	Qty
	Part Number	Part Number		
1	See Section 9.7.1	See Section 9.7.1	ELECTRIC PANEL	1
2	See Section 9.7.3	See Section 9.7.3	ASSEMBLY, CONTROL BLOCK	1
3	See Section 9.7.2	See Section 9.7.2	HYDRAULIC PANEL	1
4	Z-9150-03	Z-9150	ASSEMBLY, FLOW CONTROL	1
5	Z-9149-03	Z-9149	ASSEMBLY, PRESSURE CONTROL	1

9.7.1 Electric Panel

The Electric Panel does not require regular general maintenance.

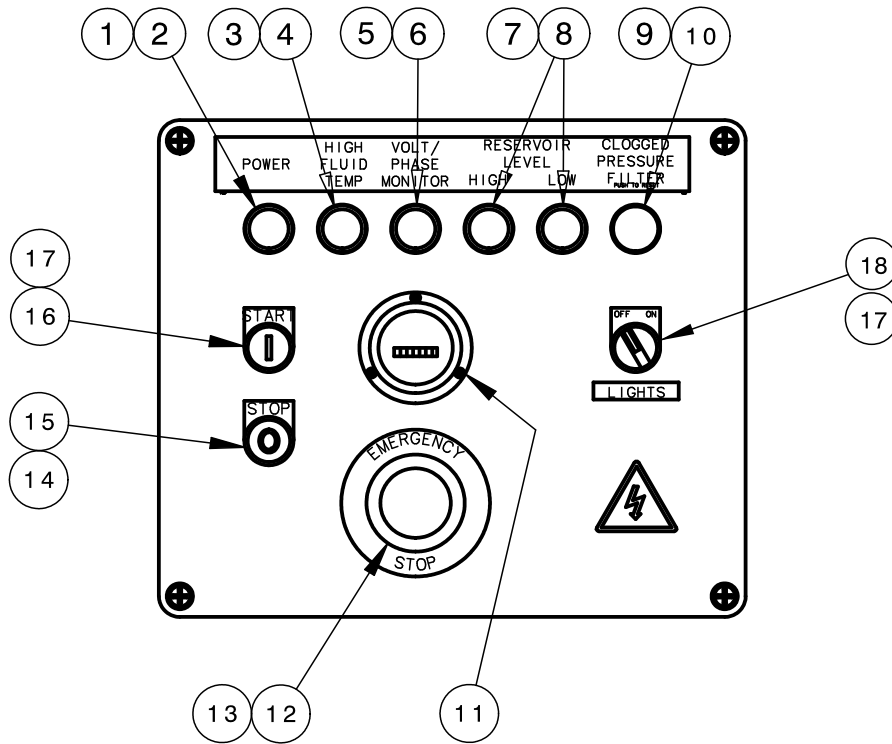

Parts List

Item	Component	Part Number	Description	Qty
1	Standard	EC-1945-01	Light, Diffused Pilot	1
2	Standard	EC-1951-MN5G	Power, Module w/Latch	1
3	Option	EC-1945-03	Light, Diffused Pilot	1
4	Option	EC-1951-MN5Y	Power, Module w/Latch	1
5	Option	EC-1945-03	Light, Diffused Pilot	1
6	Option	EC-1951-MN5Y	Power, Module w/Latch	1
7	Option	EC-1945-04	Light, Diffused Pilot	2
8	Option	EC-1951-MN5B	Power, Module w/Latch	2
9	Option	EC-1952	Push Button, Illuminated/Flush	1
10	Option	EC-1944	Power, Module w/Contact/Latch	1
11	Option	EC-1577	Hour Meter (50 Hz Operation)	1
		EC-1578	Hour Meter (60 Hz Operation)	1
12	Option	EC-1948	Switch, Emergency Stop	1
13	Standard	EC-1946-MX02	Contact Block w/Latch	1
14	Standard	EC-1953-ME205	Push Button, Non-Illuminated	1
15	Standard	EC-1946-MX01	Contact Block w/Latch	1
16	Standard	EC-1953-MF306	Push Button, Non-Illuminated	1
17	Standard	EC-1946-MX10	Contact Block w/Latch1	1
18	Special	EC-1947	Switch, Selector Non-Illuminated	1
N/S	Special	EC-1767	Light Base	6
N/S	Special	EC-1825	Light Bulb	6
N/S	Special	SC-1776	Light Shield	6

9.7.2 Hydraulic Panel

Annual calibration of instrumentation is recommended. See Section 11.0 – *Calibration of Instrumentation* for details of calibration.

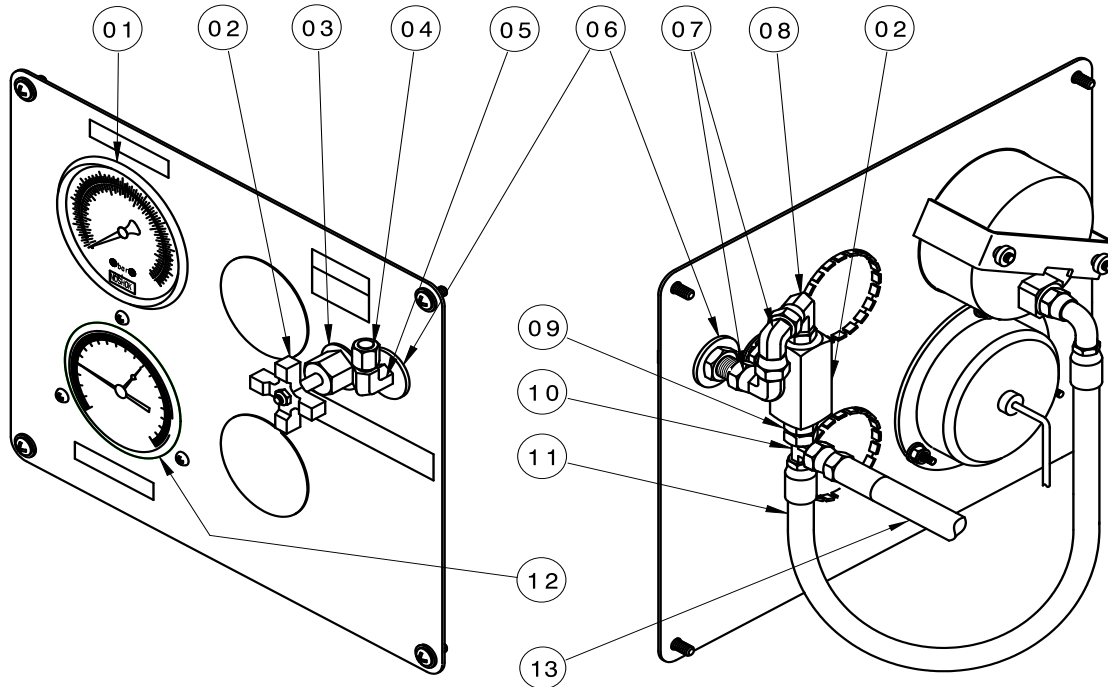

Parts List

Model Number	Fluid Type
5813	MIL-PRF-5606
5823	MIL-PRF-83282
5833	Aviation Phosphate Ester, Type IV and V
5834	MIL-PRF-87257

Item	5813, 5823, 5843	5833	Description	Qty
	Part Number	Part Number		
1	HC-2144	HC-2144	GAUGE, PRESSURE	1
2	HC-1900-03	HC-1900-02	VALVE, NEEDLE	1
3	HC-1122	HC-1122	KIT, PANEL MOUNTING	1
4	N-2008-03-S	N-2008-03-S	CAP, 1/4 JIC	1
5	N-2022-03-S	N-2022-03-S	ELBOW, BULKHEAD UNION #4	1
6	G-1250-1080W	G-1250-1080W	FLATWASHER, 7/16 WIDE	1
7	N-2002-03-S	N-2002-03-S	ELBOW, 90° SWIVEL NUT #4	2
8	N-2049-07-S-V	N-2049-07-S-E	ELBOW, 90° SWIVEL 6-4	1
9	N-2007-03-S-V	N-2007-03-S-E	CONNECTOR, STRAIGHT THREAD	1
10	N-2016-03-S	N-2016-03-S	TEE, SWIVEL NUT RUN #4	1
11	TF-1038-16*24.0	TF-1040-42*24.0	ASSEMBLY, HOSE	1
12	HC-2268-03	HC-2268-02	GAUGE, PYROMETER	1
13	TF-1038-16*32.0	TF-1040-42*32.0	ASSEMBLY, HOSE	1

9.7.3 Control Block Assembly

The Control Block Assembly components do not require regular general maintenance.

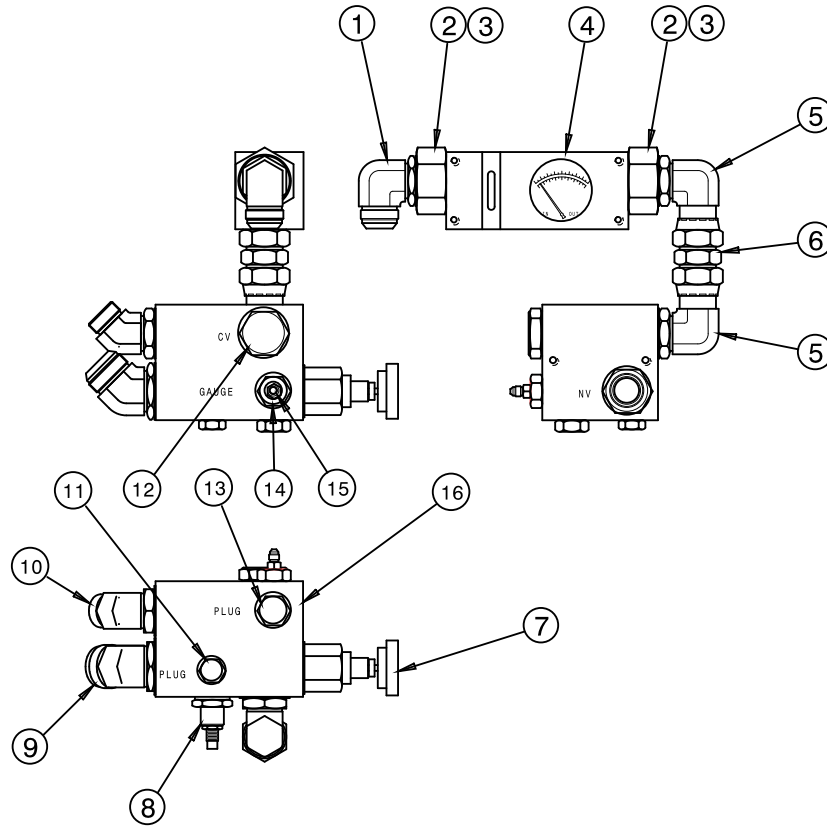

Parts List

Model Number	Fluid Type
5813	MIL-PRF-5606
5823	MIL-PRF-83282
5833	Aviation Phosphate Ester, Type IV and V
5834	MIL-PRF-87257

Item	5813, 5823, 5843	5833	Description	Qty
	Part Number	Part Number		
1	N-2001-27-S-V	N-2973-S-E	ELBOW, STRAIGHT THREAD	1
2	N-2676	N-2676	REDUCER, STRAIGHT THREAD MODIFIED	2
3	HC-2014-924	HC-2013-924	O-RING, SERIES 3	2
4	HC-2075	HC-2075-A1	FLOWMETER (CALIBRATED)	1
5	N-2634-07-S-V	N-2634-07-S-E	ELBOW, 90° SWIVEL, ORFS TUBE END (-20)	2
6	N-2665-13-S-V	N-2665-13-S-E	ORFS TUBE END (-20)	1
7	HC-2213	HC-2214	VALVE, NEEDLE	1
8	HC-2665	HC-1772	VALVE, RELIEF CARTRIDGE	1
9	N-2042-14-S-V	N-2042-14-S-E	ELBOW, 45° STRAIGHT THREAD (-24)	1
10	N-2042-25-S-V	N-2974-S-E	ELBOW, MALE 45°	1
11	N-2053-07-S-V	N-2053-07-S-E	PLUG, O-RING HEX HEAD (-10)	1
12	HC-2664	HC-2103	VALVE, CHECK	1
13	N-2053-08-S-V	N-2053-08-S-E	PLUG, O-RING HEX HEAD (-12)	1
14	N-2463-34-S-V	N-2463-34-S-E	FITTING, REDUCER/EXPANDER (12-4)	1
15	N-2007-03-S-V	N-2007-03-S-E	CONNECTOR, STRAIGHT THREAD (-04)	1
16	J-3331	J-3331	MANIFOLD, PRESSURE	1

9.7.3.a System Pressure Relief Valve

The System Pressure Relief Valve does not require regular general maintenance. It is possible however, for a contaminant to hold the relief valve in a partially open condition. If service is required, the new or repaired relief valve must be reset to 4,250 psig.

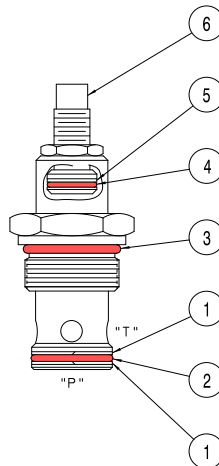

Parts List

Model Number	Fluid Type
5813	MIL-PRF-5606
5823	MIL-PRF-83282
5833	Aviation Phosphate Ester, Type IV and V
5834	MIL-PRF-87257

Item	5813, 5823, 5843	5833	Description	Qty
	Part Number	Part Number		
1	HC-2037	HC-2037	RING, BACKUP	2
2	HC-2007-119	HC-2006-119	O-RING, SERIES 2	1
3	HC-2014-916	HC-2013-916	O-RING, SERIES 3	1
4	HC-2007-015	HC-2006-015	O-RING, SERIES 2	1
5	HC-2020-015	HC-2020-015	RING, BACKUP	1
◆ 6	HC-2665	HC-1772	VALVE, PRESSURE RELIEF (NOT SET)	1

◆ Item 6 consists of Items 1 – 5.

9.7.3.b Check Valve

The Check Valve does not require regular general maintenance.

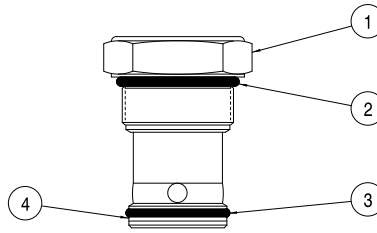

Parts List

Model Number	Fluid Type
5813	MIL-PRF-5606
5823	MIL-PRF-83282
5833	Aviation Phosphate Ester, Type IV and V
5834	MIL-PRF-87257

	5813, 5823, 5843	5833		
Item	Part Number	Part Number	Description	Qty
◆ 1	HC-2664	HC-2103	CHECK VALVE	1
2	HC-2014-920	HC-2013-920	O-RING, SERIES 3	1
3	HC-2007-124	HC-2006-124	O-RING, SERIES 2	1
4	HC-2020-124	HC-2020-124	BACKUP RING	1

◆ *Item 1 consists of Items 2 – 4.*

9.7.3.c Bypass Valve
The Bypass Valve does not require regular general maintenance.

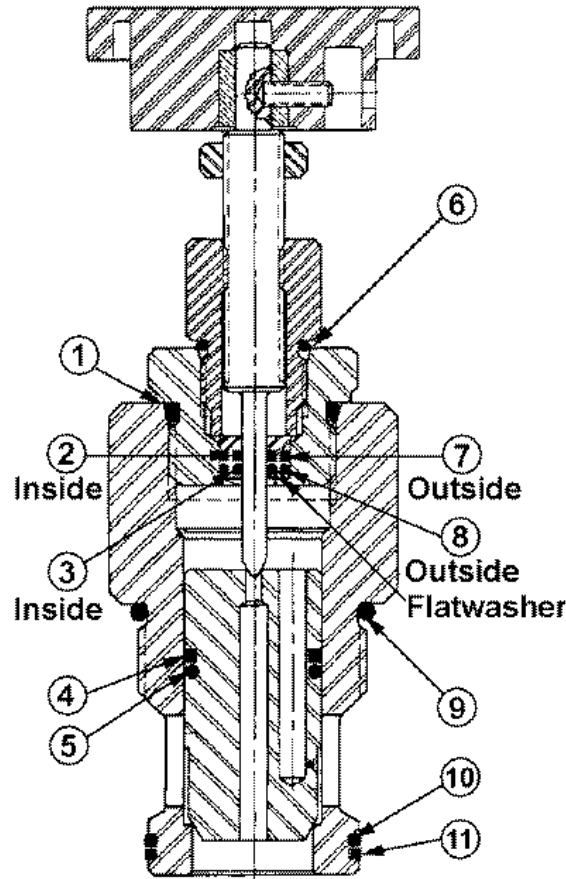

Parts List

Model Number	Fluid Type
5813	MIL-PRF-5606
5823	MIL-PRF-83282
5833	Aviation Phosphate Ester, Type IV and V
5834	MIL-PRF-87257

	5813, 5823, 5843	5833		
Item	Part Number	Part Number	Description	Qty
1	HC-2014-914	HC-2013-914	O-RING, SERIES 3	1
2	HC-2020-008	HC-2020-008	RING, BACKUP (TEFLON)	1
3	HC-2007-008	HC-2006-008	O-RING, SERIES 3	1
4	HC-2020-019	HC-2020-019	RING, BACKUP (TEFLON)	1
5	HC-2007-019	HC-2006-019	O-RING, SERIES 2	1
6	HC-2014-908	HC-2013-908	O-RING, SERIES 3	1
7	HC-2020-012	HC-2020-012	RING, BACKUP (TEFLON)	1
8	HC-2007-012	HC-2006-012	O-RING, SERIES 2	1
9	HC-2014-920	HC-2013-920	O-RING, SERIES 3	1
10	HC-2007-028	HC-2006-028	O-RING, SERIES 2	1
11	HC-2020-028	HC-2020-028	RING, BACKUP (TEFLON)	1
◆12	HC-2214	HC-2214	VALVE, NEEDLE	1

◆ Item 12 consists of Items 1 – 11.

9.7.4 Pump Flow Control

The Pump Flow Control does not require regular general maintenance

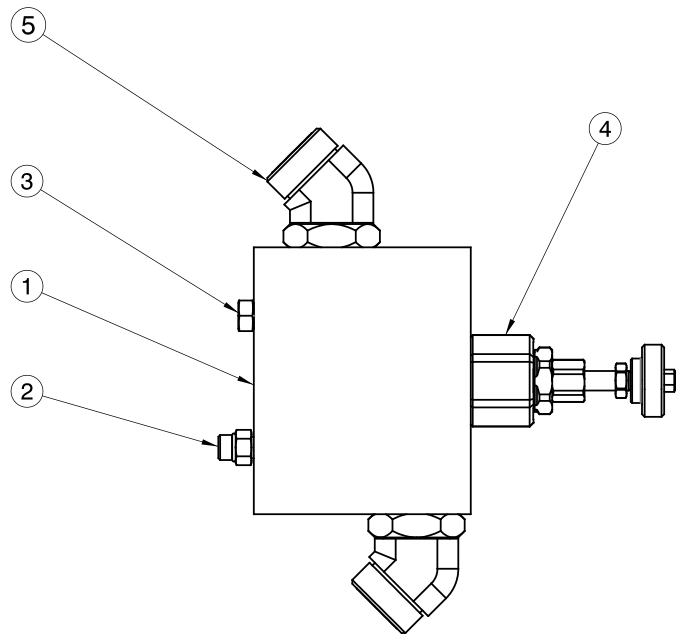

Parts List

Model Number	Fluid Type
5813	MIL-PRF-5606
5823	MIL-PRF-83282
5833	Aviation Phosphate Ester, Type IV and V
5834	MIL-PRF-87257

Item	5813, 5823, 5843	5833	Description	Qty
	Part Number	Part Number		
1	J-5799	J-5799	MAINFOLD	1
2	N-2007-08-S-V	N-2007-08-S-E	CONNECTOR, STRAIGHT THREAD	1
3	N-2053-05-S-V	N-2053-05-S-E	PLUG, HEX HEAD WITH O-RING	1
4	HC-2213	HC-2214	VALVE, NEEDLE	1
5	N-2974-S-V	N-2633-18-S-E	ELBOW, 45° ORFS	2

9.8 RESERVOIR ASSEMBLY

Replace the desiccant air filter whenever the material inside the element is pink or reddish in color (See Element label for details). The Reservoir Assembly does not require regular general maintenance. If periodic inspections for silt are desired, be certain to thoroughly clean the dome cover and surrounding area before removing the dome cover.

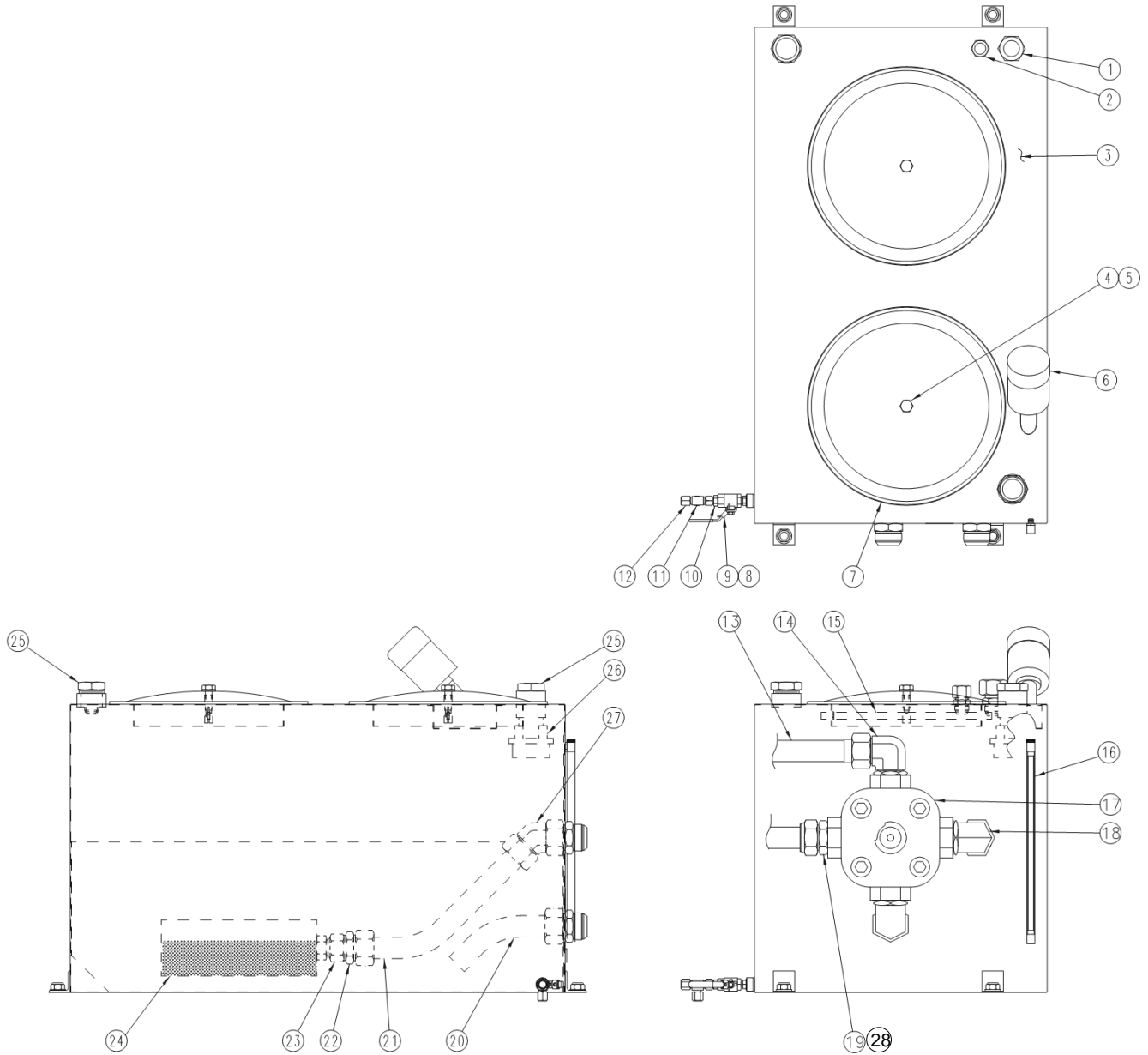

9.8 RESERVOIR ASSEMBLY (continued)

Parts List

Model Number	Fluid Type
5813	MIL-PRF-5606
5823	MIL-PRF-83282
5833	Aviation Phosphate Ester, Type IV and V
5834	MIL-PRF-87257

Item	5813, 5823, 5843	5833	Description	Qty
	Part Number	Part Number		
1	N-2008-12-S	N-2008-12-S	CAP, #24	1
2	N-2008-10-S	N-2008-10-S	CAP, #16	1
3	H-2553	H-2553	RESERVOIR, 150 GALLON (567.8 LT) STAINLESS STEEL	1
4	H-1735-02	H-1735-02	WASHER, NYLON	2
5	G-1100-110024	G-1100-110024	BOLT, HEX HEAD, GRADE 5, 5/8 -11 X 2 1/2" LONG	2
6	HC-1763	HC-1763	FILTER, DESICCANT	1
7	H-2560	H-2562	ASSEMBLY, COVER	2
8	HC-2014-908	HC-2013-908	O-RING, SERIES 3	1
9	HC-1761	HC-1761	VALVE, BALL, SAE #8 LOCKABLE	1
10	N-2007-11-S-V	N-2007-11-S-E	CONNECTOR, STRAIGHT THREAD #8 SAE X #8 JIC	1
11	N-2016-06-S	N-2016-06-S	TEE, SWIVEL RUN, #8 JIC	1
12	N-2008-06-S	N-2008-06-S	CAP, #8	2
13	Z-5803	Z-5803	ASSEMBLY, RETURN TUBE	1
14	N-2001-33-S-V	N-2001-33-S-E	ELBOW, STRAIGHT THREAD	1
15	Z-5338	Z-5338	ASSEMBLY, CLAMP	1
16	HC-2340-18	HC-1383-18	GAUGE, SIGHT	1
17	HC-2657	HC-2198	VALVE, SELECTOR	1
18	N-2049-32-S-V	N-2049-32-S-E	ELBOW, 90° SWIVEL, #32 SAE	2
19	N-2007-33-S-V	N-2007-33-S-E	CONNECTOR, STRAIGHT THREAD	1
20	Z-5802	Z-5802	ASSEMBLY, HYDRAULIC TUBE	1
21	Z-5801	Z-5801	ASSEMBLY, HYDRAULIC TUBE	1
22	N-2009-30-S	N-2009-30-S	CONNECTOR, MALE	1
23	N-2210-31-S	N-2210-31-S	REDUCER, PIPE THREAD	1
24	HC-1397-07	HC-1397-07	DIFFUSER, 3" NPT	1
25	N-2206-09-S	N-2206-09-S	PLUG, HEX HEAD, 2" NPT	2
26	HC-1542	HC-1542	STRAINER, NIPPLE STYLE	1
27	N-2081-11-S	N-2081-11-S	ELBOW, 45° SWIVEL NUT	1
28	N-3011	N-3011	ANCHOR, FLANGE	1

9.9 PRESSURE MANIFOLD ASSEMBLY

The Pressure Manifold does not require regular general maintenance other than ensuring fitting connections remain tight and leak free.

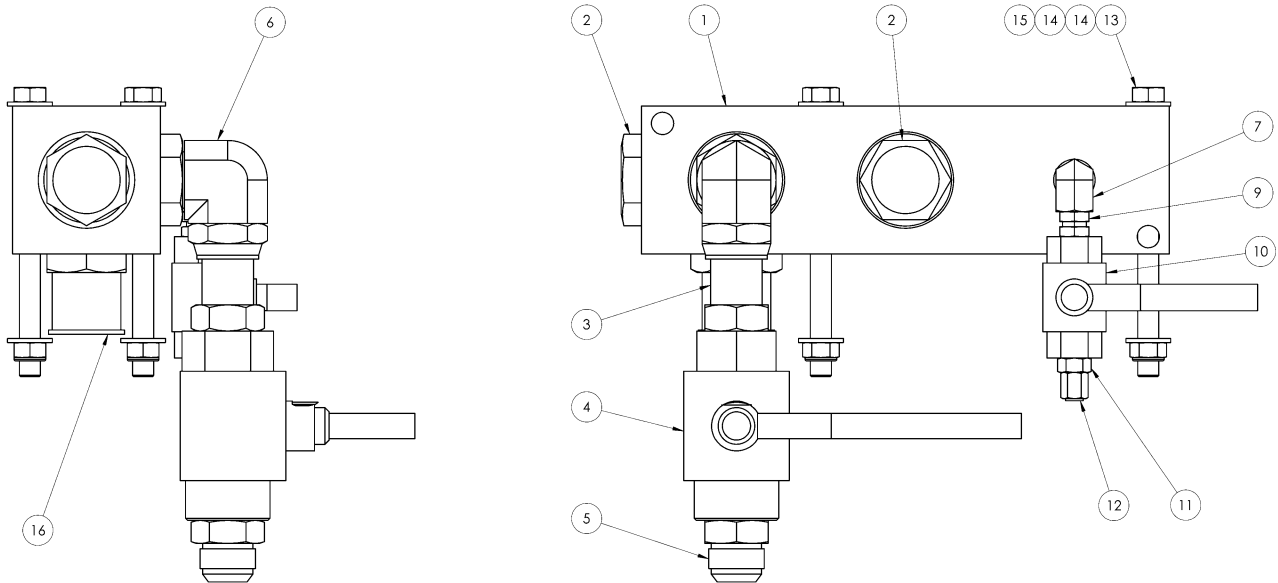

Parts List

Model Number	Fluid Type
5813	MIL-PRF-5606
5823	MIL-PRF-83282
5833	Aviation Phosphate Ester, Type IV and V
5834	MIL-PRF-87257

Item	5813, 5823, 5843	5833	Description	Qty
	Part Number	Part Number		
1	HC-2054	HC-2054	MANIFOLD, PRESSURE	1
2	N-2053-11-S-V	N-2053-11-S-E	PLUG, O-RING HEX HEAD	2
3	N-2650-06-S-V	N-2650-06-S-E	CONNECTOR, ORFS SWIVEL	1
4	HC-2206-05	HC-1771-05	VALVE, BALL	1
5	N-2975-S-V	N-2975-S-E	CONNECTOR, STRAIGHT THREAD	1
6	N-2630-20-S-V	N-2630-20-S-E	ELBOW, 90° ORFS	1
7	N-2661-02-S-V	N-2661-02-S-E	ELBOW, STRAIGHT THREAD	1
9	N-2464-05-S-V	N-2464-05-S-E	UNION, STRAIGHT THREAD	1
10	HC-2206-02	HC-1771-02	VALVE, BALL	1
11	N-2007-05-S-V	N-2007-05-S-E	CONNECTOR, STRAIGHT THREAD	1
12	N-2008-03-S	N-2008-03-S	CAP	1
13	G-1100-109564	G-1100-109564	BOLT, ½-20 X 6-1/2 HED HD GR 5	2
14	G-1250-1090N	G-1250-1090N	FLATWASHER, ½ NARROW	4
15	G-1202-1095	G-1202-1095	STOPNUT, ½-20 ELASTIC	2
16	N-2507-25-S-V	N-2507-25-S-E	CONNECTOR, STRAIGHT THREAD (-20)	

This page left blank intentionally.

9.10 RETURN MANIFOLD ASSEMBLY

The Return Manifold does not require regular general maintenance.

NOTE: DO NOT attempt to adjust the Return System Pressure Relief Valve. See Section 9.9.1 – Return System Pressure Relief Valve for details.

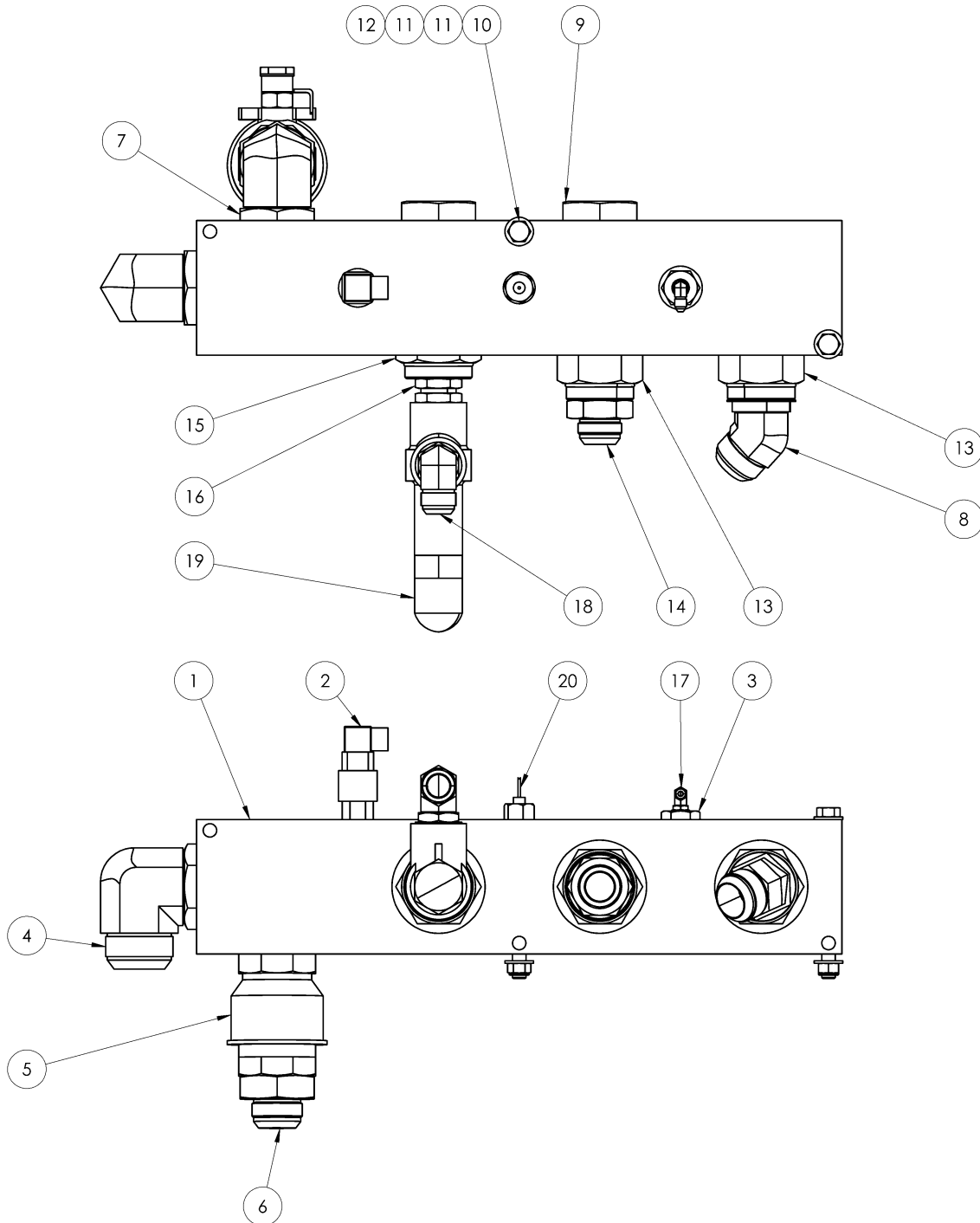

9.10 RETURN MANIFOLD ASSEMBLY (continued)

Parts List

Model Number	Fluid Type
5813	MIL-PRF-5606
5823	MIL-PRF-83282
5833	Aviation Phosphate Ester, Type IV and V
5834	MIL-PRF-87257

Item	5813, 5823, 5843	5833	Description	Qty
	Part Number	Part Number		
1	HC-2049	HC-2049	MANIFOLD, RETURN	1
2	EC-1782-03	EC-1782-02	SWITCH, TEMPERATURE	1
3	N-2463-34-S-V	N-2463-34-S-E	FITTING, REDUCER/EXPANDER	1
4	N-2001-33-S-V	N-2001-33-S-E	ELBOW, STRAIGHT THREAD	1
5	HC-2058-03	HC-2058-03	VALVE, BALL	1
6	N-2007-32-S-V	N-2007-32-S-E	CONNECTOR, STRAIGHT THREAD	1
7	N-2666-09-S-V	N-2666-09-S-E	ELBOW, STRAIGHT THREAD	1
8	N-2042-14-S-V	N-2042-14-S-E	ELBOW, 45 DEG STR THD	1
9	N-2053-13-S-V	N-2053-13-S-E	PLUG, HEX HD W/O-RING	2
10	G-1100-109560	G-1100-109560	BOLT, 1/2-20 X 6.0" HEX HD GR 5	2
11	G-1250-1090N	G-1250-1090N	FLATWASHER. 1/2 NARROW	4
12	G-1202-1095	G-1202-1095	STOPNUT, 1/2-20 ELASTIC	2
13	N-2463-28-S-V	N-2463-28-S-E	FITTING, REDUCER/EXPANDER	2
14	N-2007-30-S-V	N-2007-30-S-E	CONNECTOR, STRAIGHT THREAD	1
15	N-2463-26-S-V	N-2463-26-S-E	FITTING, REDUCER/EXPANDER	1
16	N-2464-10-S-V	N-2464-10-S-E	UNION, #16 STRAIGHT THREAD	1
17	N-2001-03-S-V	N-2001-03-S-E	ELBOW, STRAIGHT THREAD	1
18	N-2001-24-S-V	N-2001-24-S-E	ELBOW, STRAIGHT THREAD	1
19	HC-2202	HC-2202	VALVE,PRE-SET PRESS RELIEF(PE)	1
20	HC-2268-03	HC-2268-02	GAUGE, PYROMETER (PE)	1

9.10.1 Return System Pressure Relief Valve

The Return System Pressure Relief Valve can be purchased as a preset assembly. If the relief valve is serviced by the end user, the valve must be set to crack at 150+/-7 psig **before** being re-installed on the HPU.

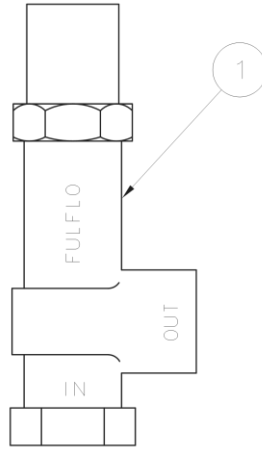

Parts List

Model Number	Fluid Type
5813	MIL-PRF-5606
5823	MIL-PRF-83282
5833	Aviation Phosphate Ester, Type IV and V
5834	MIL-PRF-87257

	5813, 5823, 5843	5833		
Item	Part Number	Part Number	Description	Qty
1	HC-2201	HC-2202	VALVE, PRESSURE RELIEF (PRE-SET)	1
N/S	◆ HC-2007-220	◆ HC-2006-220	O-RING, SERIES 2	1

◆ **Included with Item 1.**

This page left blank intentionally.

9.11 ELECTRICAL COMPONENTS

Regularly inspect the external power cord for nicks, cuts, abrasion, and fluid damage. Replace power cord if damage is found. Reference **9.0 Provision of Spares** for recommended spare fuses.

Reference following page for component descriptions.

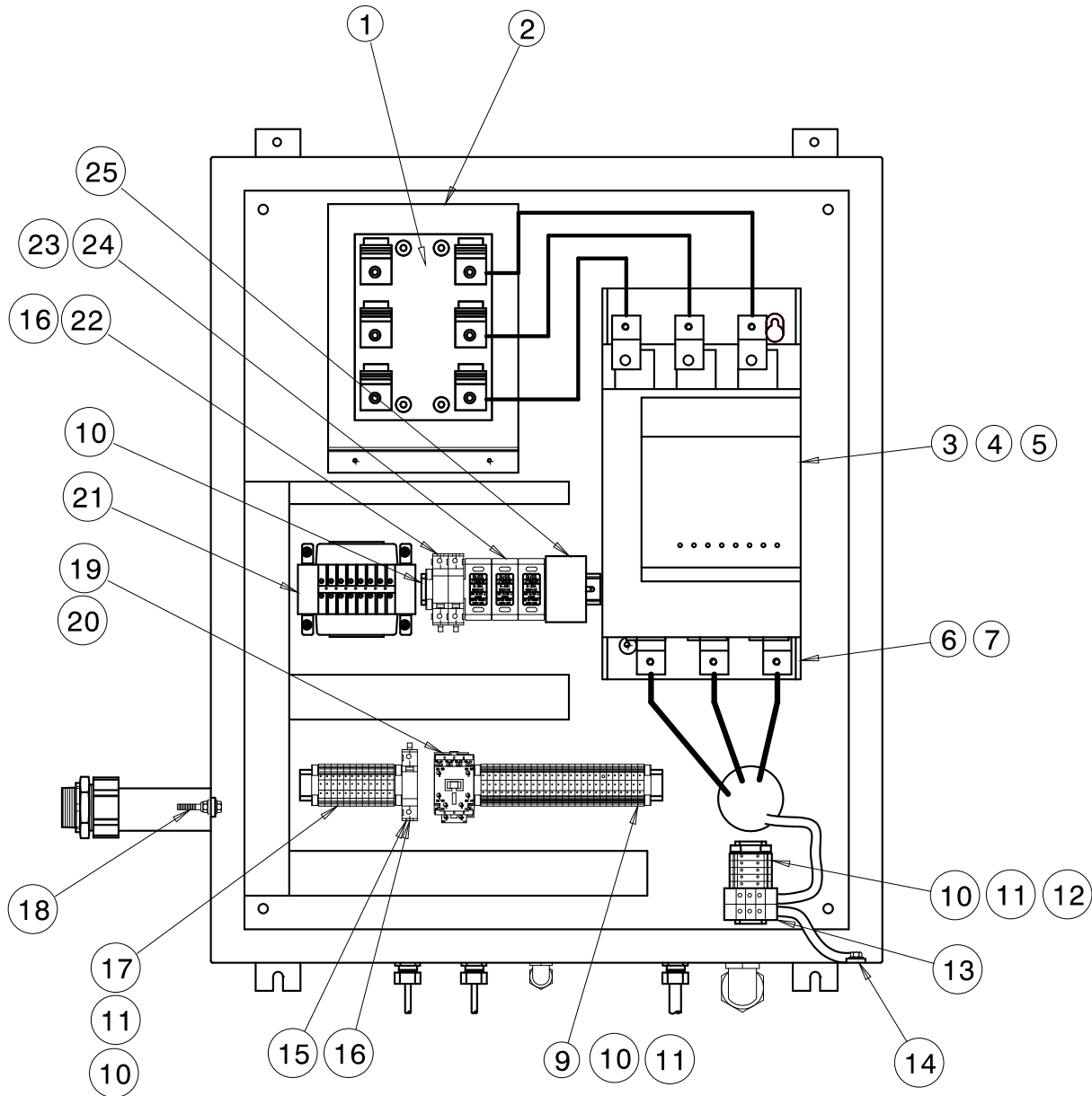

100 HP ASSEMBLY

NOTE: Set Item 6 to Automatic Reset position. Set "A2" to its corresponding full load amps listed in 5.2.4 Motor Power Requirements. Wire per Electrical Schematic INS-1608. Reference Wire Diagram INS-1661.

9.11 ELECTRICAL COMPONENTS *(continued)*

Parts List

Fluid Type: Aviation Phosphate Ester, Type IV

Item	Part Number	Description	Qty
2	EC-1560	Fuse Block, Class J	1
4	EC-1724	Kit, Terminal Lug	2
5	EC-1746	Kit, Terminal Cover	1
6	EC-1564	Relay, Overload	1
7	EC-1603	Shield, Anti-Tamper	1
9	EC-1956-02	Block, IEC Terminal Red	26
10	EC-1959	Anchor, IEC, End	7
11	EC-1960-01	Barrier, End	3
12	EC-1958	Block, IEC Ground	5
13	EC-1957	Block, IEC Ground	2
14	EC-1532-04	Lug, Ground	2
15	EC-1542-14	Fuse, LP-CC Low Peak 1-6/10 A (<i>Secondary</i>)	1
16	EC-1541-01	Fuse Holder, IEC Class CC	Ref
17	EC-1956-03	Block, IEC Terminal, Blue	12
18	EC-1432-04	Lug, Ground	1
19	EC-1591-04	Latch, Mechanical	1
20	EC-1564	Relay, Control	1
21	EC-1804-04	Transformer, Control (200 W)	1
23	EC-1596-01	Fuse Holder, Class J	3
24	EC-1557-01	Fuse, Class J (Heat Exchanger)	3
26	EC-1675-12	Fuse, KTK-R 2 amp (<i>Optional</i>)	Ref
N/S	EC-1227-05*0600	Power Cord	1

THE FOLLOWING PARTS ARE APPLICATION SPECIFIC

Be sure to locate the correct voltage and hertz of the unit before selecting the part

Item	60 Hz Applications			Description	Qty
	380	460	575		
1	EC-1556-08	EC-1556-07	EC-1556-06	Fuse, Class J	3
3	EC-1974	EC-1974	EC-2022	Controller, Softstart Motor	1
22	EC-1726-14	EC-1726-11	EC-1726-08	Fuse, Class CC (<i>Primary</i>)	2
23	EC-1596-01	EC-1596-01	EC-1596-01	Fuse Holder, Class J	3
25	EC-1543-03	EC-1543-04	EC-1543-05	Monitor, Phase (<i>Optional</i>)	Ref

Item	50 Hz Applications			Description	Qty
	380	415	440		
1	EC-1556-09	EC-1556-08	EC-1556-08	Fuse, Class J	3
3	EC-1975	EC-1975	EC-1975	Controller, Softstart Motor	1
22	EC-1726-14	EC-1726-13	EC-1726-12	Fuse, Class CC (<i>Primary</i>)	2
23	EC-1596-01	EC-1596-01	EC-1596-01	Fuse Holder, Class J	3
25	EC-1543-03	EC-1543-04	EC-1543-05	Monitor, Phase (<i>Optional</i>)	Ref

9.12 HEAT EXCHANGER ASSEMBLY

The Heat Exchanger Assembly does not require regular general maintenance.

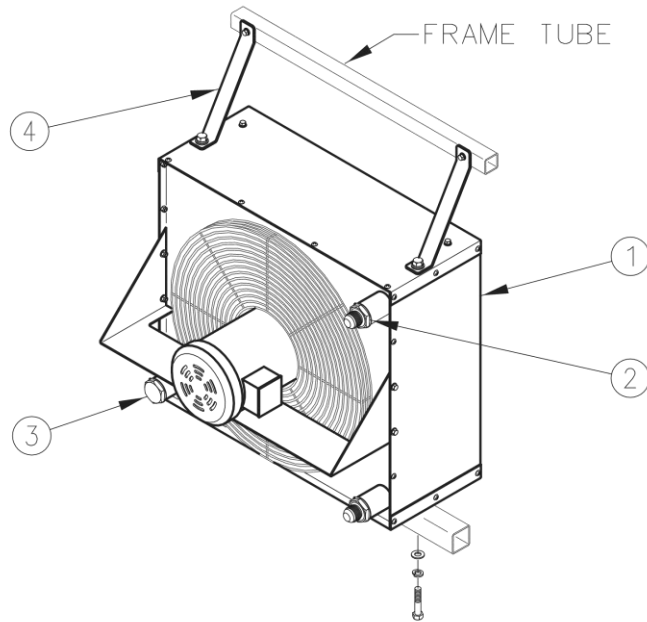

Parts List

Model Number	Fluid Type
5813	MIL-PRF-5606
5823	MIL-PRF-83282
5833	Aviation Phosphate Ester, Type IV and V
5834	MIL-PRF-87257

Item	5813, 5823, 5843	5833	Description	Qty
	Part Number	Part Number		
1	Reference Table below		HEAT EXCHANGER	1
2	N-2007-28-S-V	N-2007-28-S-E	CONNECTOR, #20 SAE X #20 JIC	2
3	N-2066-20-S-V	N-2066-20-S-E	PLUG, #20 SAE (HIDDEN)	1
4	J-3403-01	J-3403-01	STRAP	2

Voltage	Frequency	Part Number
380V	60 Hz	HC-2138-01
460V	60 Hz	HC-2138-01
575V	60 Hz	HC-2138-02
380V	50 Hz	HC-2138-01
415V	50 Hz	HC-2138-01
440V	50 Hz	HC-2138-01

9.13 EXTERNAL COMPONENTS

Keep HPU clean. Do not allow labels to become damaged; thusly illegible. Regularly inspect casters and floor locks to ensure safe working condition.

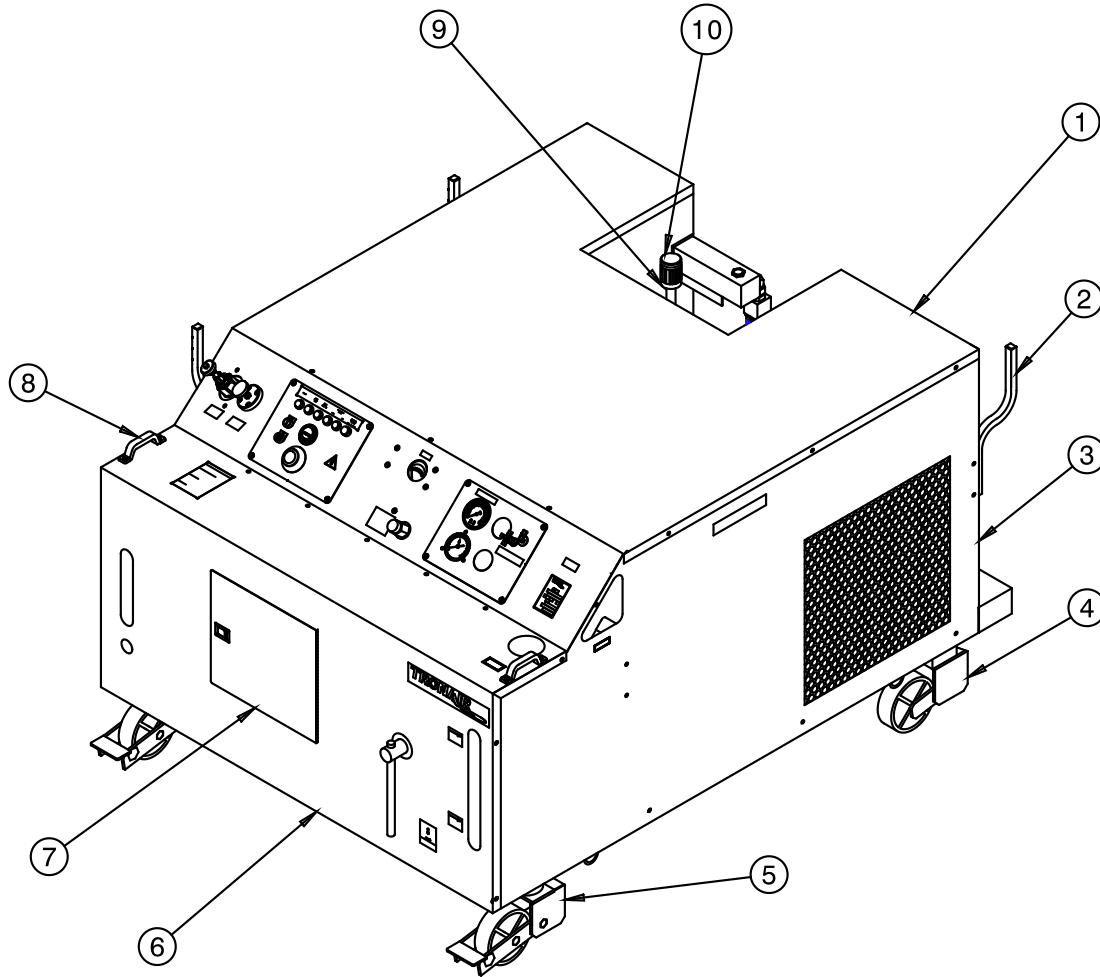

Parts List

Item	Part Number	Description	Qty
1	S-1799-01	TOP PANEL	1
2	Z-5549-01	HANGER	3
3	Z-5382-01	RIGHT SIDE PANEL	1
4	U-1102	RIGID CASTER	2
5	U-1101	SWIVEL CASTER	2
6	Z-9146	FRONT PANEL	1
7	Z-5397	FRONT ACCESS DOOR	1
8	H-1780	HANDLE	2
9	EC-1794	BOX, VERTICAL MOUNT JUNCTION	1
10	EC-1791	LIGHT, POLE MOUNTED STACK	1
N/S	Z-5383-01	LEFT SIDE PANEL	1
N/S	S-1804-01	RETURN MANIFOLD ACCESS PANEL	1
N/S	S-1896-01	SKIRT PANEL (UNDER ELECTRICAL BOX)	1
N/S	S-1798-01	BACK PANEL	1

9.14 ADDITIONAL FEATURES

9.14.1 50 ft (15.2 m) Hoses (*Option B*)

Refer to Section **10.6 Hydraulic Hoses** concerning hose inspection.

Parts List

Model Number	Fluid Type
5813	MIL-PRF-5606
5823	MIL-PRF-83282
5833	Aviation Phosphate Ester, Type IV and V
5834	MIL-PRF-87257

5813, 5823, 5843		5833	
Part Number	Part Number	Description	Qty
TF-1038-40*300	TF-1040-05*300	PRESSURE HOSE, 25 FT/7.6 M	1 per Option
TF-1039-04*300	TF-1041-04*300	RETURN HOSE, 25 FT/7.6 M	1 per Option
N-2011-10-S	N-2011-10-S	UNION, #16	1 per Option
N-2011-12-S	N-2011-12-S	UNION, #12	1 per Option

9.14.2 Electric Reservoir Level (*Option L*)

The Electric Reservoir Level switch does not require regular general maintenance. Panel indicator lights will indicate low or high fluid level.

NOTE: Wire per Electrical Schematic INS-1608. Reference Wiring Diagram INS-1661. Reference 9.7.1 Electrical Panel for Panel Light.

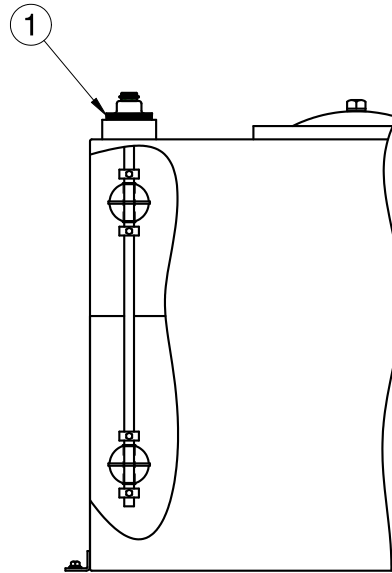

Parts List

Item	Part Number	Description	Qty
1	EC-1783	MULTI-LEVEL SWITCH (includes Plug-in Cable)	1

9.14.3 Hand Pump (Option M)

Refer to Section 9.6 **Hydraulic Hoses** concerning hose inspection for general maintenance on Items 4, 5, 7 and 13 hose assemblies. Refer to Section 9.5.3 – **Hand Pump (Optional) Filter**.

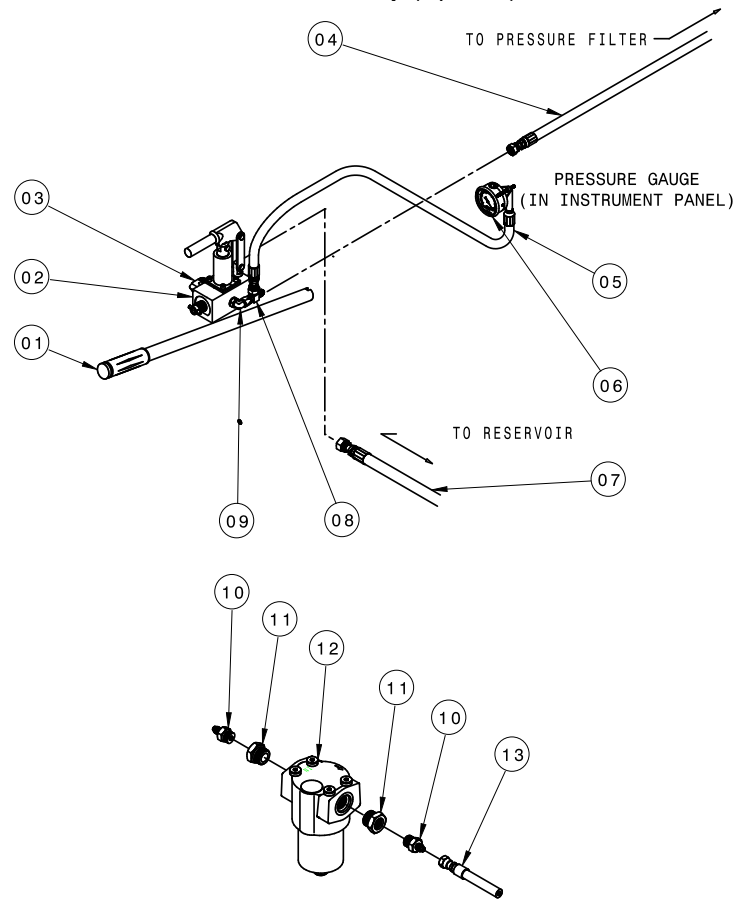

Parts List

Model Number	Fluid Type
5813	MIL-PRF-5606
5823	MIL-PRF-83282
5833	Aviation Phosphate Ester, Type IV and V
5834	MIL-PRF-87257

Item	5813, 5823, 5843	5833	Description	Qty
	Part Number	Part Number		
1	H-1009-01	H-1009-01	PUMP HANDLE	1
2	HC-1779	HC-1779	HAND PUMP, TWO STAGE	1
3	N-2001-11-S-V	N-2001-11-S-E	ELBOW, #8 SAE X #8 JIC FLARE	1
4	TF-1038-14-75.0	TF-1041-05-76.0	HOSE ASSEMBLY, #4	1
5	TF-1038-15-79.0	TF-1040-42*79.0	HOSE ASSEMBLY, #4	1
6	HC-2146	HC-2146	PRESSURE GAUGE	1
7	TF-1037-21-36.0	TF-1041-21*36.0	HOSE ASSEMBLY, #8	1
8	N-2016-03-S	N-2016-03-S	TEE, SWIVEL NUT, #4	1
9	N-2001-05-S-V	N-2001-05-S-E	ELBOW, #6 SAE X #4 JIC FLARE	1
10	N-2007-06-S-V	N-2007-06-S-E	FITTING, MALE CONNECTOR	1
11	N-2463-10-S-V	N-2463-10-S-E	REDUCER FITTING	2
12	HC-2250	HC-1777	PRESSURE FILTER	1
13	TF-1038-14-180	TF-1041-05*180	HOSE ASSEMBLY, #4	1

9.14.3.a Two Stage Pump with Relief

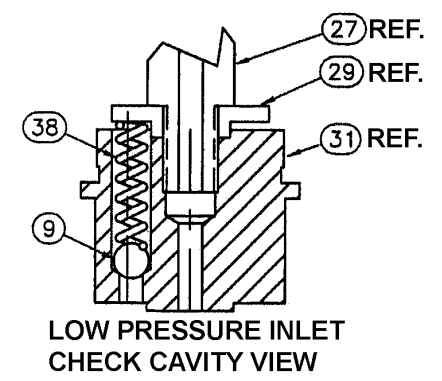
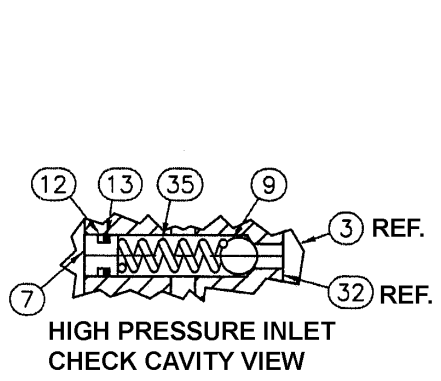
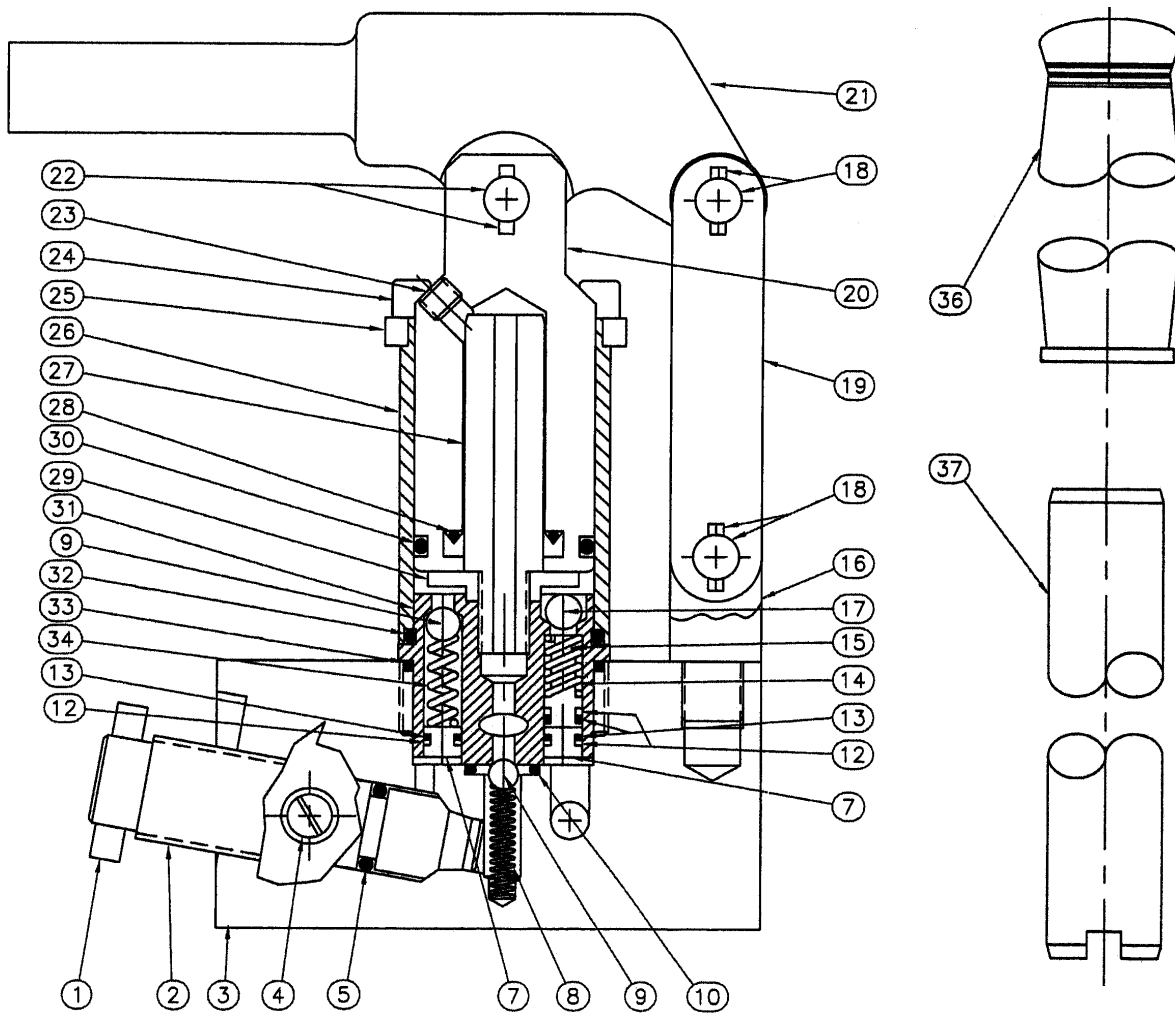

9.14.3.a Two Stage Pump with Relief (continued)

Parts List

Item	Part Number	Description	Qty
1	519-000	PIN	1
3	CXC-990022-001	BODY	1
7	505-001	PLUG, VALVE BODY	3
15	571-121	PISTON, BYPASS ASSEMBLY	1
16	508-000	PIVOT	1
20	566-125	PISTON L.P	1
23	583-120	PLUG	1
24	09-ADDF-04-20 X 56	TIE ROD	4
25	582-125	FLANGE	1
26	563-121	TUBE	1
27	562-125	H.P. PISTON	1
29	564-120	RETAINER	1
31	560-120	VALVE BODY	1
36	H-1223	GRIP, HANDLE	1
37	H-1009-01	HANDLE WITH GRIP	1
	HK-1095	KIT, INTERNAL PARTS; consists of:	
6	(Not Shown)	BALL, RELEASE	0
8		SPRING, OUTLET CHECK	1
9		BALL, CHECK	4
14		SPRING, BYPASS	1
17		BALL, BYPASS	1
34		SPRING, L.P. OUTLET	1
35		SPRING, H.P. OUTLET	1
38		SPRING, INTAKE L.P	1
	HK-1030	KIT, PUMP SEAL; consists of:	
5		O-RING, EPR	1
10		O-RING, EPR	1
12		BACKUP RING (TEFLON)	4
13		O-RING, EPR	4
28		H.P. PISTON SEAL	1
30		O-RING, EPR	1
32		O-RING, EPR	1
33		O-RING, EPR	1
	HK-1068	KIT, PUMP LINKAGE; consists of:	
18		PIN LINKAGE ASSEMBLY	2
19		STRAP	2
21		HANDLE BRACKET	1
22		CLEVIS PIN ASSEMBLY	1
	HK-3117	KIT, RELEASE SCREW; consists of:	
2		SCREW, RELEASE/RELIEF	1
4		RETAINER, RELEASE SCREW	1

9.14.4 Towing Trailer (Option M)

Capacity 6,500 lbs (2,948 kg)
 Front Axle Capacity 3,250 lbs (1,474 kg)
 Rear Axle Capacity 3,250 lbs (1,474 kg)
 Tires 13x5x10 - Rated at 2,580 lbs (1,170 kg) at 6 mph (9.6 kph)

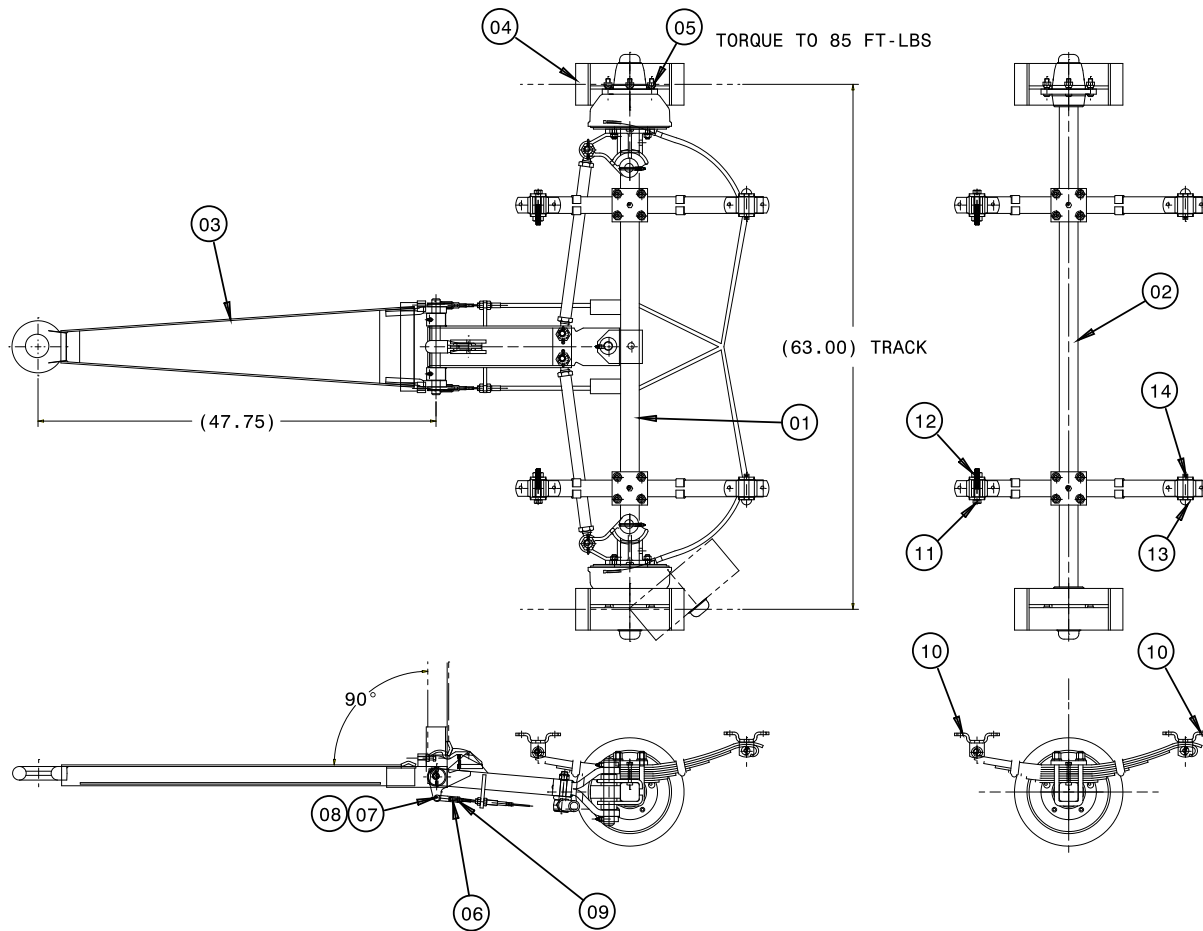

Parts List

Item	Part Number	Description	Qty
1	9-2196	ASSEMBLY, FRONT AXLE	1
2	18-2146	ASSEMBLY, REAR AXLE	1
3	47-3504	ASSEMBLY, DRAWBAR	1
4	1-3761	ASSEMBLY, WHEEL & TIRE	4
5	4603-1	NUT, WHEEL ½-20 UN	20
6	5205	YOKE	2
7	5206	PIN, YOKE	2
8	4800-2	PIN, COTTER ¾ X 0.75	2
9	4601-47	NUT, HEX ¾ -24 NF	2
10	4251	BRACKET, SPRING	8
11	4901-19	BOLT, GRADE 5, 9/16 -12 UN X 3.75" LONG	4
12	4601-33	NUT, HEX, 9/16 -12 UN	4
13	5403-1	RIVET	4
14	4800-3	PIN, COTTER, 1/8 X 1" LONG	4

9.15 REPLACEMENT LABELS PARTS LISTS

9.15.1 Base Unit

Part Number	Description	Qty
V-1001	"Made in USA"	1
V-1033	"TRONAIR"	1
V-1050	ISO Electrical Shock Symbol	2
V-1348	"FLOW (Increase)"	1
V-1366	"HPU BY-PASS VALVE"	1
V-1374	"ROTATION"	1
V-1470	"CAUTION..."	1
V-1882	Control Panel Lights	1
V-1883	"HOUR METER"	1
V-1884	"FLOWMETER"	1
V-1886	"PYROMETER"	1
V-1888	"SHUT-OFF/CALIBRATION PORT"	1
V-1893	"SAMPLE VALVE"	1
V-1894	"PRESSURE"	1
V-1895	"RETURN"	1
V-1896	"MAXIMUM OIL LEVEL"	1
V-1897	"MINIMUM OIL LEVEL"	1
V-1898	"PRESSURE and FLOW CONTROLS INSIDE"	1
V-1900	"WARNING KEEP 5 FT CLEAR..."	2
V-1914	Reservoir Selector Valve	1
V-1918	"PE"	1
V-1919	"OPERATING INSTRUCTIONS..."	1

9.15.2 Fluid Labels

Model 5813 Parts List

Fluid Type: MIL-PRF-5606

Part Number	Description	Qty
V-1975	"MIL-PRF-5606"	2

Model 5823 Parts List

Fluid Type: MIL-PRF-83282

Part Number	Description	Qty
V-1976	"MIL-PRF-83282"	2

Model 5833 Parts List

Fluid Type: Aviation Phosphate Ester, Type IV and V

Part Number	Description	Qty
V-1977	"PHOSPHATE ESTER FLUIDS ONLY"	2

Model 5843 Parts List

Fluid Type: MIL-PRF-87257

Part Number	Description	Qty
V-2027	"MIL-PRF-87257"	2

9.15.3 Filter Element Kit Labels

Model 5813, 5823 & 5843 Parts List

Fluid Type: MIL-PRF-5606, MIL-PRF-83282 & MIL-PRF-87257

Part Number	Description	Qty
V-2601	"REPLACEMENT FILTER ELEMENT K-5033"	1
V-2600	"REPLACEMENT FILTER ELEMENT K-5034"	1
V-1916	"REPLACEMENT DESICCANT FILTER ELEMENT HC-1763"	1

Model 5833 Parts List

Fluid Type: Aviation Phosphate Ester, Type IV

Part Number	Description	Qty
V-1956	"REPLACEMENT FILTER ELEMENT K-3588"	1
V-1955	"REPLACEMENT FILTER ELEMENT K-3587"	1
V-1916	"REPLACEMENT DESICCANT FILTER ELEMENT HC-1763"	1

9.15.4 Split System (Option C) Labels

Part Number	Description	Qty
V-2004	"SYSTEM 1 PRESSURE"	1
V-2005	"SYSTEM 2 PRESSURE"	1
V-2006	"SYSTEM 1 RETURN"	1
V-2007	"SYSTEM 2 RETURN"	1

9.15.5 Hand Pump (Option M) Labels

Model 5813, 5823 & 5843 Parts List

Fluid Type: MIL-PRF-5606, MIL-PRF-83282 & MIL-PRF-87257

Part Number	Description	Qty
V-1887	"HAND PUMP PRESSURE"	1
V-1915	"HAND PUMP"	1
V-2050	"REPLACEMENT FILTER ELEMENT K-3831"	1

Model 5833 Parts List

Fluid Type: Aviation Phosphate Ester, Type IV

Part Number	Description	Qty
V-1887	"HAND PUMP PRESSURE"	1
V-1915	"HAND PUMP"	1
V-1989	"REPLACEMENT FILTER ELEMENT K-3752"	1

10.0 PROVISION OF SPARES

10.1 SOURCE OF SPARE PARTS

Spare parts may be obtained from the manufacturer:

TRONAIR, Inc.	Telephone: (419) 866-6301 or 800-426-6301
1 Air Cargo Pkwy East	Fax: (419) 867-0634
Swanton, Ohio 43558 USA	E-mail: sales@tronair.com
	Website: www.tronair.com



For Spare Parts, Operations & Service Manuals or Service Needs:
Scan the QR code or visit Tronair.com/aftermarket

10.2 RECOMMENDED SPARE PARTS LISTS

It is recommended that the following spare parts be kept on hand and available for immediate use during maintenance.

10.2.1 Spare Electrical Parts

Part Number	Description	Qty
Refer to Section 9.10 Electrical Components Item 22	Fuse, Transformer Primary	2
EC-1542-12	Fuse, Transformer Secondary	1
Refer to Section 9.10 Electrical Components Item 24	Fuse, Heat Exchanger	3

10.2.2 Spare Parts

Model 5813, 5823 & 5843 Parts List

Fluid Type: MIL-PRF-5606, MIL-PRF-83282 & MIL-PRF-87257

Part Number	Description	Qty
HC-1763	Desiccant Filter Element	1
K-5033	Kit, Pressure Filter Element	1
K-5034	Kit, Return Filter Element	1
*	Kit, Shaft Seal	1
K-3831	Kit, Hand Pump Filter Element (Optional)	1

* Call Tronair for details

Model 5833 Parts List

Fluid Type: Aviation Phosphate Ester, Type IV

Part Number	Description	Qty
HC-1763	Desiccant Filter Element	1
K-3588	Kit, Pressure Filter Element	1
K-3587	Kit, Return Filter Element	1
*	Kit, Shaft Seal	1
K-3752	Kit, Hand Pump Filter Element (Optional)	1

* Call Tronair for details

11.0 CALIBRATION OF INSTRUMENTATION

All gauges on the Hydraulic Power Unit can be either returned to Tronair for calibration or certified by the end user if proper calibration equipment is available. Gauges returned to Tronair for calibration will be tested with standards traceable to N.I.S.T. (National Institute of Standards and Technology). Tronair recommends calibration of instrumentation at yearly intervals, but actual calibration dates may be based upon frequency of use and the end users quality system. For information on returning gauges for calibration, Reference 12.1 – Source of Calibration.

11.1 SOURCE OF CALIBRATION

<p>TRONAIR, Inc. 1 Air Cargo Pkwy East Swanton, Ohio 43558 USA</p>	<p>Telephone: (419) 866-6301 or 800-426-6301 Fax: (419) 867-0634 E-mail: sales@tronair.com Website: www.tronair.com</p>
---	---

11.2 ANALOG PRESSURE GAUGE – System Pressure

11.2.1 Self Calibration

An accurate pressure calibration gauge is required for calibration of the System Pressure gauge. There are two methods available. Method A can be used if the HPU is equipped with a calibration port (*Option Q*). Method B must be used if the HPU is **not** equipped with a calibration port. Follow the necessary steps below.

NOTE: Method A can only test the gauge up to the rated operating pressure of the HPU (4,000 psi).

Method A: Shut off HPU and disconnect from aircraft. Close the calibration port **Shut-off Valve** on the instrument panel of the HPU. Attach the “Master” calibration gauge to the **Calibration Port** on the instrument panel.

Set up the HPU as follows:

Reservoir Selector Valve	Set to HPU Reservoir
Bypass Valve.....	Open
Pressure Ball Valves (at rear of unit).....	Closed
Return Ball Valves (at rear of unit)	Closed

Start the HPU. Open the calibration port Shut-off Valve. Close the Bypass valve to build system pressure. Record gauge values at the designated increments.

Open the Bypass valve.

Shut off the HPU and close the calibration port Shut-off Valve before disconnecting the “Master” calibration gauge.

Method B: Shut off the HPU and disconnect it from the power source. Remove the **Hydraulic Panel** from the front instrument panel (four screws). Disconnect the hose from the System Pressure gauge (remove gauge from panel if necessary). Attach calibration test equipment to the gauge and record gauge values at the designated increments.

SYSTEM PRESSURE GAUGE (HC-2144)

Applied Pressure (System Pressure Gauge) (psig)	Minimum Acceptable (psig)	Maximum Acceptable (psig)	Gauge Movement (Direction)	Indicated Pressure (Calibration Gauge) (psig)
1000	910	1090	Increasing	
2000	1910	2090	Increasing	
3000	2910	3090	Increasing	
4000	3910	4090	Increasing	
5000	4910	5090	Increasing	
6000	5910	6090	Increasing	
5000	4910	5090	Decreasing	
4000	3910	4090	Decreasing	
3000	2910	3090	Decreasing	
2000	1910	2090	Decreasing	
1000	910	1090	Decreasing	

Allowable operating tolerance: +/- 1.5% of full scale (90 psig) at room temperature (70° F).

11.3 ANALOG PRESSURE GAUGE (Hand Pump Pressure- *Option M Only*)

11.3.1 Self Calibration

An accurate pressure calibration gauge is required for calibration of the Hand Pump Pressure gauge. Follow the necessary steps below.

Shut off the HPU and disconnect it from the power source. Remove the **Hydraulic Panel** from the front instrument panel (four screws). Disconnect the hose from the Hand Pump Pressure gauge (remove gauge from panel if necessary). Attach calibration test equipment to the gauge and record gauge values at the designated increments.

HAND PUMP PRESSURE GAUGE (HC-2146)

Applied Pressure (Hand Pump Pressure Gauge) (psig)	Minimum Acceptable (psig)	Maximum Acceptable (psig)	Gauge Movement (Direction)	Indicated Pressure (Calibration Gauge) (psig)
1000	700	1300	Increasing	
2000	1700	2300	Increasing	
5000	4800	5200	Increasing	
8000	7700	8300	Increasing	
10,000	9700	10,300	Increasing	
8000	5940	8300	Decreasing	
5000	4800	5200	Decreasing	
2000	1700	2300	Decreasing	
1000	700	1300	Decreasing	

Allowable operating tolerance: +/- 3% of full scale (300 psig) at room temperature (70° F).
+/- 2% of full scale for middle third of scale (200 psig) at room temperature (70° F).

11.4 ANALOG TEMPERATURE GAUGE (*Pyrometer*)

11.4.1 Self Calibration

An accurate temperature calibration gauge is required for calibration of the Pyrometer. The pyrometer bulb is located in the return manifold (rear of unit) and can be accessed by removal of the HPU top panel. See Section 9.7.2 – Pyrometer for location. Follow the necessary steps below.

- 1 Remove the pyrometer bulb from the return manifold by removing the slotted brass nut that retains the bulb in the well.
- 2 Connect the temperature calibration gauge to the bulb of the pyrometer.

The Temperature Value Must Be:

Pyrometer Temperature Display (° F)	Minimum Acceptable (° F)	Maximum Acceptable (° F)	Temperature Calibration gauge (° F)
160	158	162	

12.0 IN SERVICE SUPPORT

Contact Tronair, Inc. for technical services and information. See Section 1.3 – Manufacturer.

13.0 GUARANTEES/LIMITATION OF LIABILITY

Tronair products are warranted to be free of manufacturing or material defects for a period of one year after shipment to the original customer. This is solely limited to the repair or replacement of defective components. This warranty does not cover the following items:

- a) Parts required for normal maintenance
- b) Parts covered by a component manufacturers warranty
- c) Replacement parts have a 90-day warranty from date of shipment

If you have a problem that may require service, contact Tronair immediately. Do not attempt to repair or disassemble a product without first contacting Tronair, any action may affect warranty coverage. When you contact Tronair be prepared to provide the following information:

- a) Product Model Number
- b) Product Serial Number
- c) Description of the problem

If warranty coverage is approved, either replacement parts will be sent or the product will have to be returned to Tronair for repairs. If the product is to be returned, a Return Material Authorization (RMA) number will be issued for reference purposes on any shipping documents. Failure to obtain a RMA in advance of returning an item will result in a service fee. A decision on the extent of warranty coverage on returned products is reserved pending inspection at Tronair. Any shipments to Tronair must be shipped freight prepaid. Freight costs on shipments to customers will be paid by Tronair on any warranty claims only. Any unauthorized modification of the Tronair products or use of the Tronair products in violation of cautions and warnings in any manual (including updates) or safety bulletins published or delivered by Tronair will immediately void any warranty, express or implied.

The obligations of Tronair expressly stated herein are in lieu of all other warranties or conditions expressed or implied. **Any unauthorized modification of the Tronair products or use of the Tronair products in violations of cautions and warnings in any manual (including updates) or safety bulletins published or delivered by Tronair will immediately void any warranty, express or implied and Tronair disclaims any and all liability for injury (WITHOUT LIMITATION and including DEATH), loss or damage arising from or relating to such misuse.**

14.0 APPENDICES

APPENDIX I	Declaration of Conformity
APPENDIX II	Hydraulic Schematic (INS-2370)
APPENDIX III	Electrical Schematic (INS-2238)
APPENDIX IV	Wiring Diagram (INS-1664)
APPENDIX V	Instrument Certification Notice
APPENDIX VI	Safety Data Sheet (SDS) MIL-PRF-5606 Hydraulic Fluid
APPENDIX VII	Safety Data Sheet (SDS) MIL-PRF-83282 Hydraulic Fluid
APPENDIX VIII	Safety Data Sheet (SDS) Aviation Phosphate Ester, Type IV and V Hydraulic Fluid



APPENDIX I

Declaration of Conformity



Declaration of Conformity

The design, development and manufacture is in accordance with European Community guidelines

Mobile Hydraulic Power Unit (Electric Motor Driven)

Relevant draft complied with by the machinery:
EN 1915-1:1995

Relevant standards complied with by the machinery:
EN 982:1996
EN 60204-1:1997
HFPA/JIC T2.24.1-1990
ISO 4021:1997
ARP 1247B
NFPA 70/NEC 1999

Identification of person empowered to sign on behalf of the Manufacturer:

A handwritten signature in cursive script that reads "Patrick Finch". The signature is written in black ink and is positioned above a solid horizontal line.

Quality Assurance Representative



APPENDIX II

**Hydraulic Schematic
(INS-2370)**

THIS DRAWING IS THE PROPERTY OF TRONAIR, INC. IT IS FURNISHED TO YOU FOR CONFIDENTIAL INFORMATION PURPOSES ONLY AND IS NOT TO BE DISCLOSED TO ANYONE ELSE OR REPRODUCED OR USED FOR MANUFACTURING PURPOSES WITHOUT THE EXPRESS WRITTEN PERMISSION OF TRONAIR, INC.

LET	REVISION	ECN	DWN	CHK	DATE
A	ORIGINAL RELEASE	20309	-	-	01-30-17

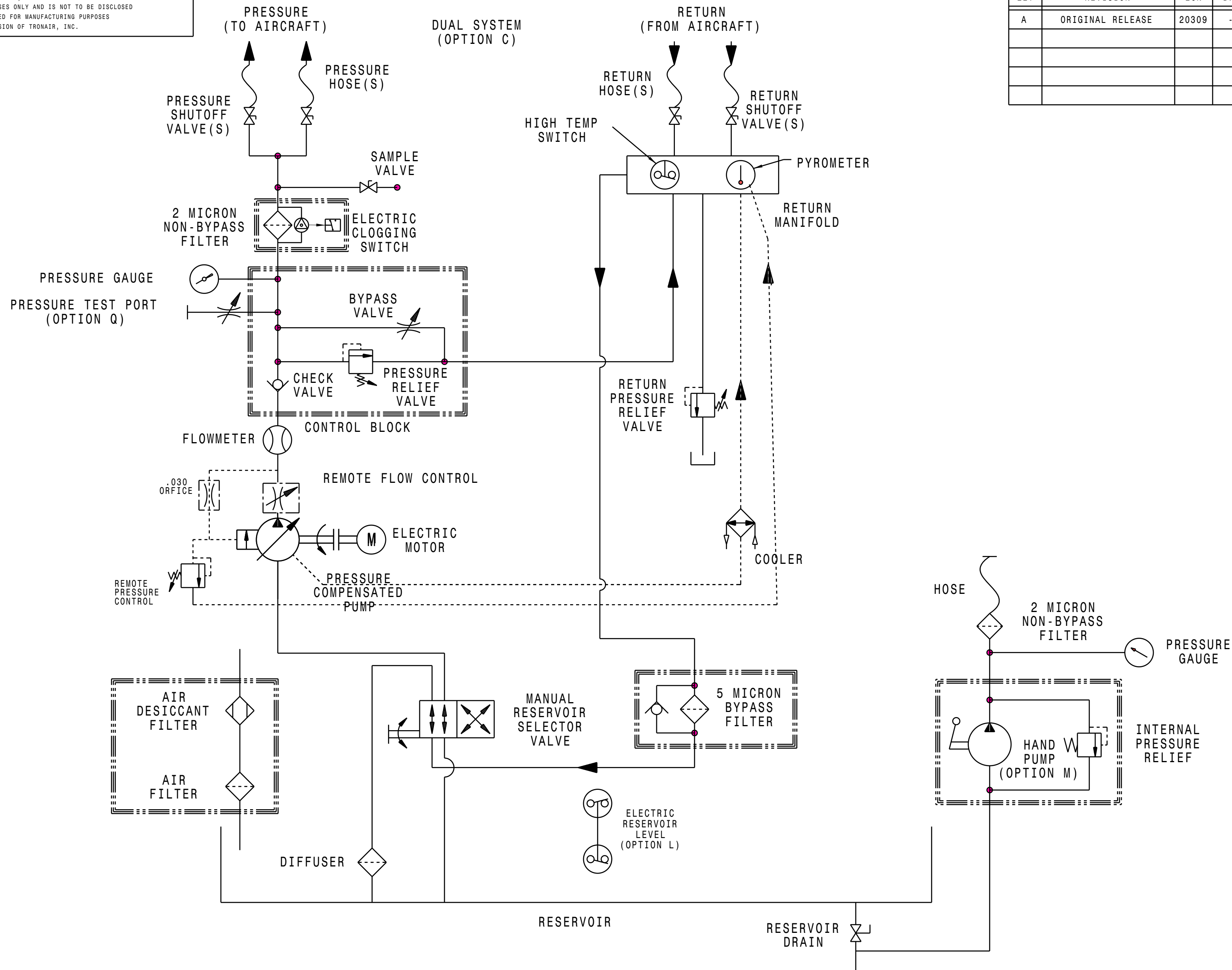

MAKE FROM:	N / A
MATERIAL:	N / A
FINISH:	N / A
REFERENCE:	N / A
SCALE:	FULL
TYPE:	N / A
SIZE:	C
DO NOT SCALE DRAWING	

BREAK ALL SHARP EDGES AND CORNERS
TOLERANCES UNLESS OTHERWISE SPECIFIED

DECIMAL .X ± .100
.XX ± .030
.XXX ± .010

FRACTION X/XX ± 1/16

ANGLES: ± 1/2 DEGREE

< > INDICATES CRITICAL DIMENSIONS
() INDICATES REFERENCE DIMENSIONS

TRONAIR AIRCRAFT GROUND SUPPORT EQUIPMENT

DWN BY CDG CKD BY PEH 01-31-17

SCHEMATIC, HYDRAULIC

05 **INS-2370** REV A



APPENDIX III

**Electrical Schematic
(INS-2238)**

THIS DRAWING IS THE PROPERTY OF TRONAIR, INC. IT IS FURNISHED TO YOU FOR CONFIDENTIAL INFORMATION PURPOSES ONLY AND IS NOT TO BE DISCLOSED TO ANYONE ELSE OR REPRODUCED OR USED FOR MANUFACTURING PURPOSES WITHOUT THE EXPRESS WRITTEN PERMISSION OF TRONAIR, INC.

LET	REVISION	ECN	DWN	CHK	DATE
A	ORIGINAL RELEASE	19173	-	-	11-27-13
B	ADDED WIRES 70 & 71	21208	ADO	PEH	03-19-19

COMPONENT ABBREVIATION
 MS - MOTOR STARTER
 SS - SOFT START
 MTR - MOTOR
 SJ - SWITCH
 CR - CONTROL RELAY
 HR - HOURMETER
 FU - FUSE
 TR - TRANSFORMER
 LT - LIGHT
 SN - SENSOR
 PE - POTENTIAL EARTH

WIRE COLORS:
 - LT - BLUE
 - NE - RED
 - INTERCONNECTION - RED
 - 3 PHASE - BLACK
 - GROUND - GREEN-YELLOW

(X) - DEVICE TERMINATION
 [] - TERMINAL BLOCK CONNECTION
 1TB - GROUND TERMINAL BLOCK
 2TB - NEUTRAL TERMINAL BLOCK
 3TB - CONTROL TERMINAL BLOCK
 --- OPTIONS JUMPER

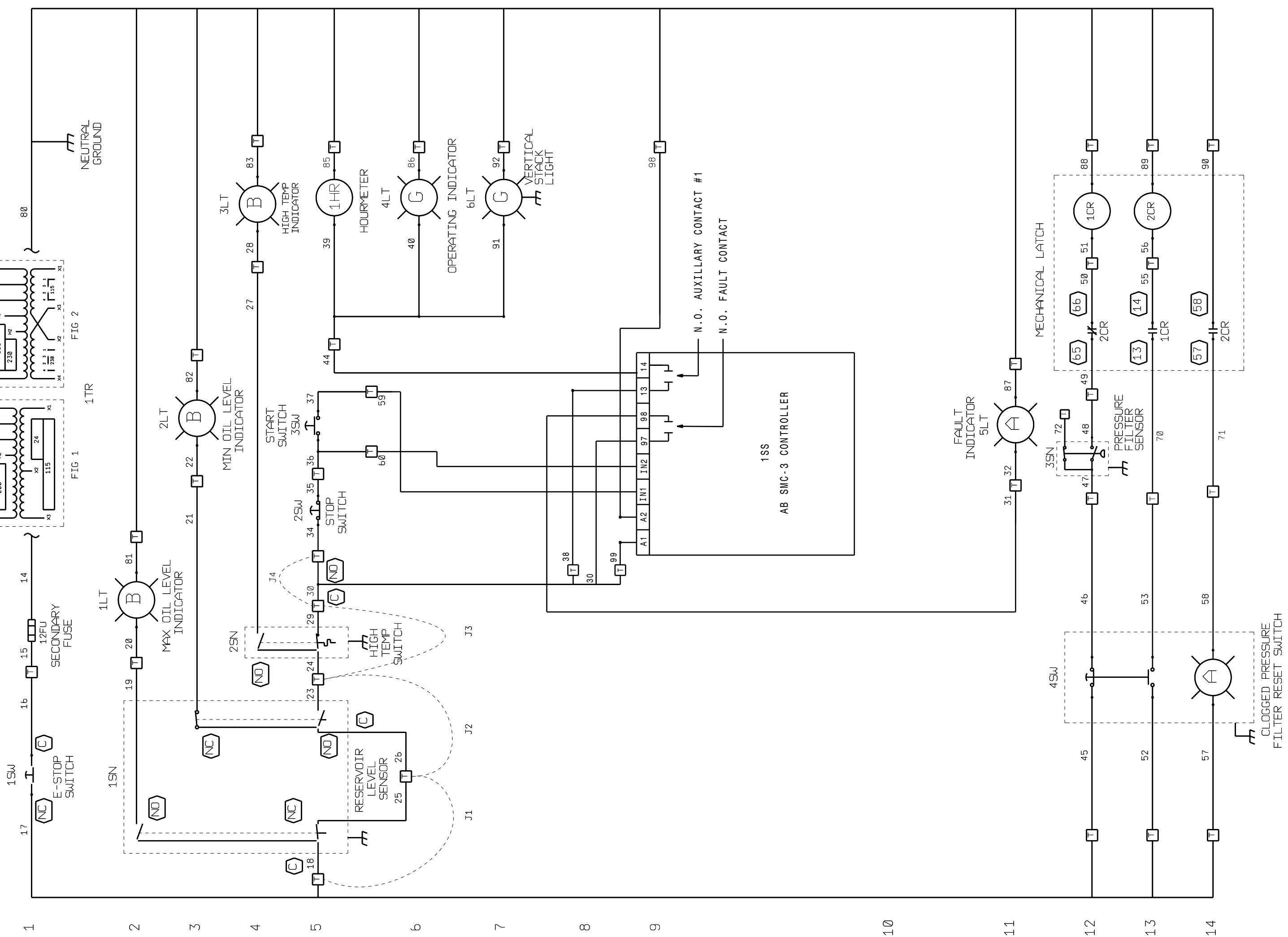
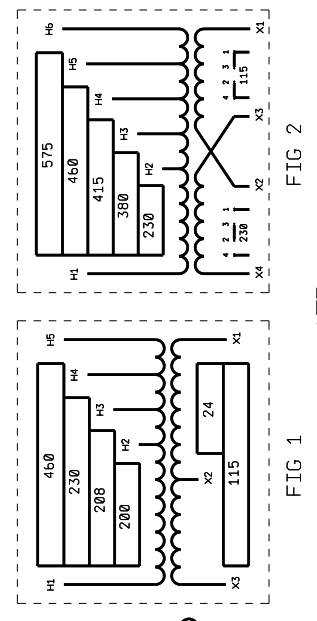
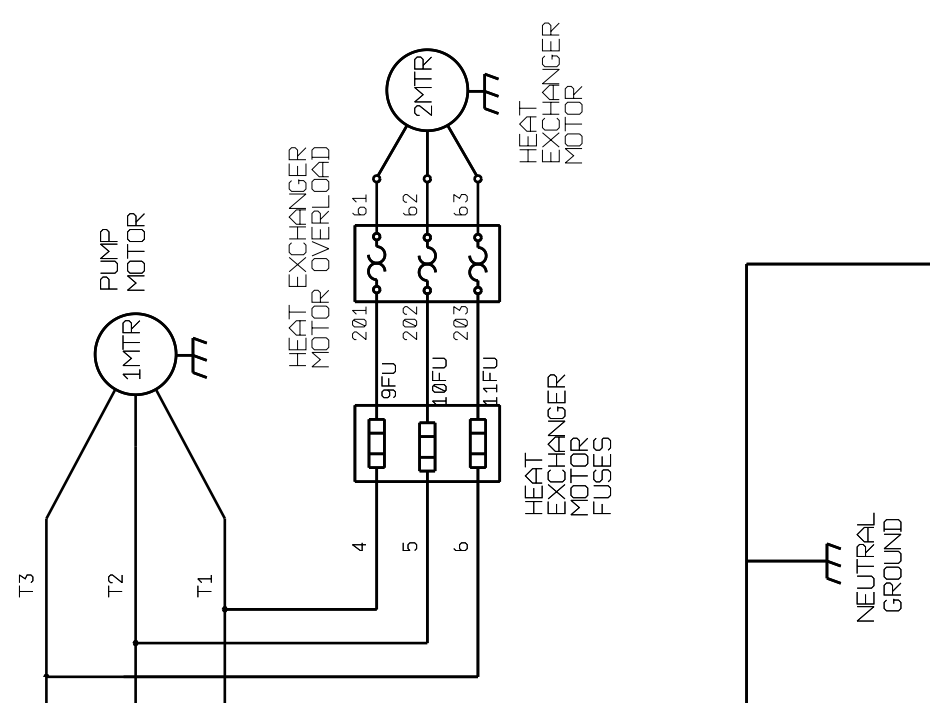

MAKE FROM: N / A	TYPE: N / A
MATERIAL: N / A	FINISH: MILL
REFERENCE:	SIZE: []
SCALE: N. S. R.	DO NOT SCALE DRAWING

BREAK ALL SHARP EDGES AND CORNERS
 TOLERANCES UNLESS OTHERWISE SPECIFIED

DECIMAL	.X	± .100
	.XX	± .030
	.XXX	± .010
FRACTION	X/XX	± 1/16

ANGLES: ± 1/2 DEGREE
 < > INDICATES CRITICAL DIMENSIONS
 () INDICATES REFERENCE DIMENSIONS

TRONAIR AIRCRAFT GROUND SUPPORT EQUIPMENT

DWN BY	WCG	CKD BY	PEH	DATE	11-27-13
SCHEMATIC, HPU ELECTRICAL (CE/CSA)					
05	INS-2238			REV	B



APPENDIX IV

Wiring Diagram (INS-1664)

THIS DRAWING IS THE PROPERTY OF TRONAIR, INC. IT IS FURNISHED TO YOU FOR CONFIDENTIAL INFORMATION PURPOSES ONLY AND IS NOT TO BE DISCLOSED TO ANYONE ELSE OR REPRODUCED OR USED FOR MANUFACTURING PURPOSES WITHOUT THE EXPRESS WRITTEN PERMISSION OF TRONAIR, INC.

LET	REVISION	EDN	DUN	CHK	DATE
-	ORIGINAL RELEASE	11765	-	-	05-18-01
A	1. ADDED STACK LT. 2. WIRE 93 WPS 91 3. UPDATED GEOMETRY	12249	WCG	PEH	11-04-02
B	CHANGED SOFT START AND WIRING	15354	WCG	PEH	05-06-08
C	ADDED TERMINALS	16953	JMB	PEH	04-15-09
D	DELETED 41, 42, 61 TERMINALS	18738	JMB	PEH	09-20-12
E	ADDED WIRES 70 & 71	21208	ADD	PEH	03-19-19

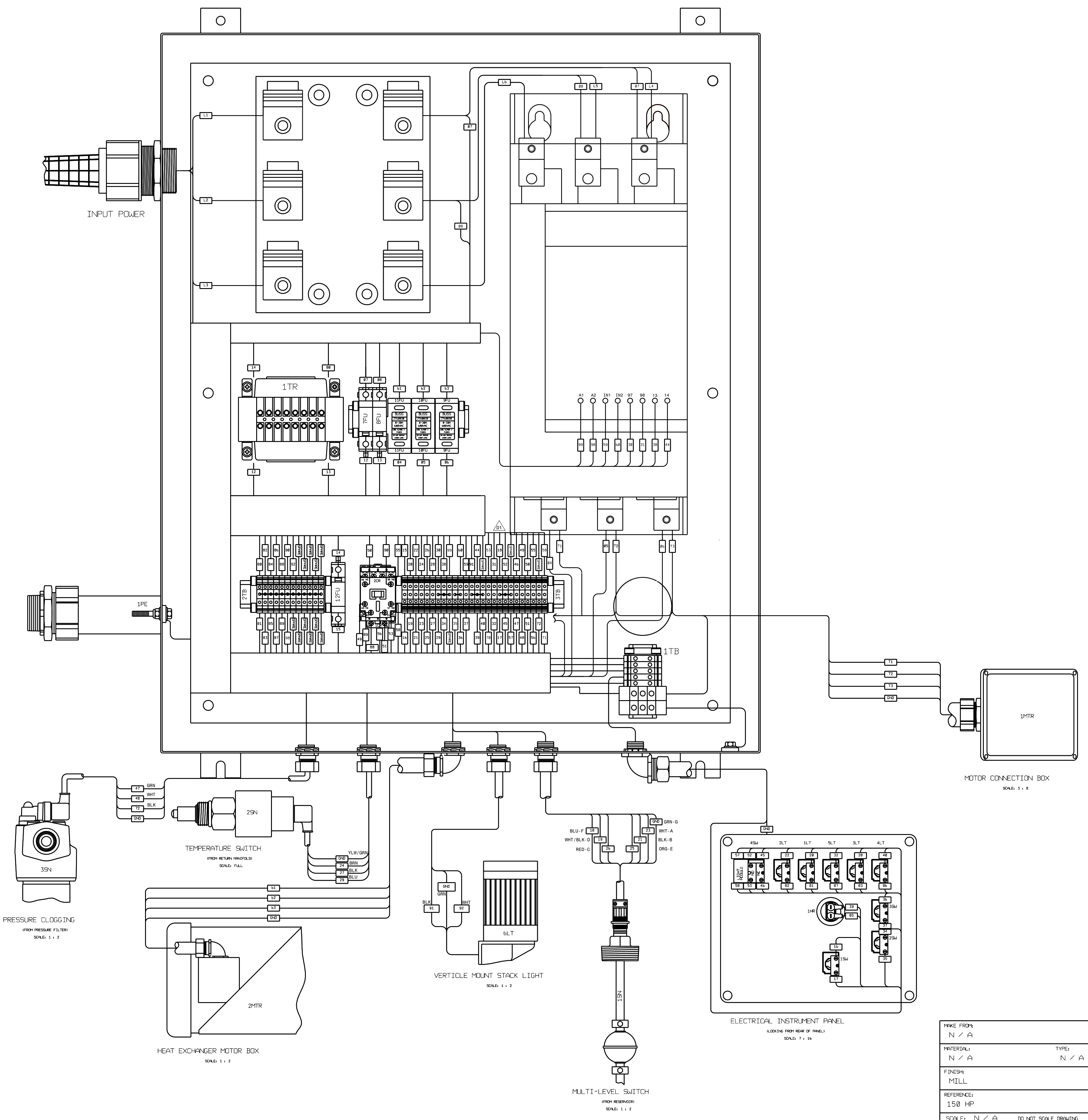

MAKE FRIDS N / A MATERIAL: N / A FINISH: MILL REFERENCE: 150 HP SCALE: N / A DO NOT SCALE DRAWING	TYPE: N / A SIZE: D	BREAK ALL SHARP EDGES AND CORNERS TOLERANCES UNLESS OTHERWISE SPECIFIED DECIMAL .X ± .100 .XX ± .030 .XXX ± .010 FRACTION X/XX ± 1/16 ANGLES: ± 1/2 DEGREE < > INDICATES CRITICAL DIMENSIONS () INDICATES REFERENCE DIMENSIONS	TRONAIR AIRCRAFT GROUND SUPPORT EQUIPMENT DWN BY SJD CKD BY WJL 05-18-01 INSTRUCTION, WIRING DIAGRAM (CE) 05 INS-1664 REV E
---	------------------------------	---	---



APPENDIX V

Instrument Certification Notice



Instrument Certification Notice

The gauge Certificates of Calibration supplied for the gauge(s) on this unit contain the calibration data for the actual instrument calibrated, along with the calibration date of the **STANDARD** used to perform the calibration check.

The due date for re-calibration of the instrument should be based upon the date the instrument was placed in service in your facility. Re-calibration should be done on a periodic basis as dictated by the end user's quality system or other overriding requirements.

Note that Tronair, Inc. does not supply certificates of calibration on pyrometers unless requested at the time of placed order. This instrument is considered a reference indicator only and is not critical to the test(s) being performed on the aircraft.



APPENDIX VI

**Safety Data Sheet (SDS)
MIL-PRF-5606 Hydraulic Fluid**

Product Name: MOBIL AERO HFA
Revision Date: 01 Oct 2015
Page 1 of 12

SAFETY DATA SHEET

SECTION 1 PRODUCT AND COMPANY IDENTIFICATION

PRODUCT

Product Name: MOBIL AERO HFA
Product Description: Base Oil and Additives
Product Code: 201550401020, 490110-00, 970584
Intended Use: Aviation hydraulic oil

COMPANY IDENTIFICATION

Supplier: EXXON MOBIL CORPORATION
22777 Springwoods Village Parkway
Spring, TX. 77253 USA

24 Hour Health Emergency 609-737-4411
Transportation Emergency Phone 800-424-9300 or 703-527-3887 CHEMTREC
Product Technical Information 800-662-4525
MSDS Internet Address <http://www.exxon.com>, <http://www.mobil.com>

SECTION 2 HAZARDS IDENTIFICATION

This material is hazardous according to regulatory guidelines (see (M)SDS Section 15).

CLASSIFICATION:

Flammable liquid: Category 4.
Aspiration toxicant: Category 1.

LABEL:

Pictogram:



Signal Word: Danger

Hazard Statements:

H227: Combustible liquid. H304: May be fatal if swallowed and enters airways.

Precautionary Statements:

P210: Keep away from flames and hot surfaces. -- No smoking. P273: Avoid release to the environment. P280: Wear protective gloves and eye / face protection. P301 + P310: IF SWALLOWED: Immediately call a POISON CENTER or doctor/physician. P331: Do NOT induce vomiting. P370 + P378: In case of fire: Use water fog, foam, dry chemical or carbon dioxide (CO2) to extinguish. P403 + P235: Store in a well-ventilated place. Keep cool. P405: Store locked up. P501: Dispose of contents and container in accordance with local regulations.

Product Name: MOBIL AERO HFA
 Revision Date: 01 Oct 2015
 Page 2 of 12

Other hazard information:

HAZARD NOT OTHERWISE CLASSIFIED (HNOC): None as defined under 29 CFR 1910.1200.

PHYSICAL / CHEMICAL HAZARDS

Material can accumulate static charges which may cause an ignition. Material can release vapors that readily form flammable mixtures. Vapor accumulation could flash and/or explode if ignited. Combustible.

HEALTH HAZARDS

High-pressure injection under skin may cause serious damage. Excessive exposure may result in eye, skin, or respiratory irritation.

ENVIRONMENTAL HAZARDS

No significant hazards.

NFPA Hazard ID:	Health: 1	Flammability: 2	Reactivity: 0
HMIS Hazard ID:	Health: 1*	Flammability: 2	Reactivity: 0

NOTE: This material should not be used for any other purpose than the intended use in Section 1 without expert advice. Health studies have shown that chemical exposure may cause potential human health risks which may vary from person to person.

SECTION 3	COMPOSITION / INFORMATION ON INGREDIENTS
------------------	---

This material is defined as a mixture.

Hazardous Substance(s) or Complex Substance(s) required for disclosure

Name	CAS#	Concentration*	GHS Hazard Codes
2,6-DI-TERT-BUTYL-P-CRESOL	128-37-0	0.1 - < 1%	H400(M factor 1), H410(M factor 1)
DISTILLATES (PETROLEUM), HYDROTREATED LIGHT	64742-47-8	5 - < 10%	H304
HYDROTREATED LIGHT NAPHTHENIC DISTILLATE (PETROLEUM)	64742-53-6	50 - < 70%	H227, H304
HYDROTREATED MIDDLE DISTILLATE (PETROLEUM)	64742-46-7	20 - < 30%	H304
TRIPHENYL PHOSPHATE	115-86-6	0.1 - < 0.25%	H400(M factor 1), H410(M factor 1)

* All concentrations are percent by weight unless material is a gas. Gas concentrations are in percent by volume.

As per paragraph (i) of 29 CFR 1910.1200, formulation is considered a trade secret and specific chemical identity and exact percentage (concentration) of composition may have been withheld. Specific chemical identity and exact percentage composition will be provided to health professionals, employees, or designated representatives in accordance with applicable provisions of paragraph (i).

SECTION 4	FIRST AID MEASURES
------------------	---------------------------

INHALATION

Product Name: MOBIL AERO HFA

Revision Date: 01 Oct 2015

Page 3 of 12

Remove from further exposure. For those providing assistance, avoid exposure to yourself or others. Use adequate respiratory protection. If respiratory irritation, dizziness, nausea, or unconsciousness occurs, seek immediate medical assistance. If breathing has stopped, assist ventilation with a mechanical device or use mouth-to-mouth resuscitation.

SKIN CONTACT

Wash contact areas with soap and water. Remove contaminated clothing. Launder contaminated clothing before reuse. If product is injected into or under the skin, or into any part of the body, regardless of the appearance of the wound or its size, the individual should be evaluated immediately by a physician as a surgical emergency. Even though initial symptoms from high pressure injection may be minimal or absent, early surgical treatment within the first few hours may significantly reduce the ultimate extent of injury.

EYE CONTACT

Flush thoroughly with water. If irritation occurs, get medical assistance.

INGESTION

Seek immediate medical attention. Do not induce vomiting.

NOTE TO PHYSICIAN

If ingested, material may be aspirated into the lungs and cause chemical pneumonitis. Treat appropriately.

SECTION 5 FIRE FIGHTING MEASURES

EXTINGUISHING MEDIA

Appropriate Extinguishing Media: Use water fog, foam, dry chemical or carbon dioxide (CO₂) to extinguish flames.

Inappropriate Extinguishing Media: Straight Streams of Water

FIRE FIGHTING

Fire Fighting Instructions: Evacuate area. Prevent runoff from fire control or dilution from entering streams, sewers, or drinking water supply. Firefighters should use standard protective equipment and in enclosed spaces, self-contained breathing apparatus (SCBA). Use water spray to cool fire exposed surfaces and to protect personnel.

Unusual Fire Hazards: Combustible. Pressurized mists may form a flammable mixture.

Hazardous Combustion Products: Aldehydes, Incomplete combustion products, Oxides of carbon, Phosphorus oxides, Smoke, Fume, Sulfur oxides

FLAMMABILITY PROPERTIES

Flash Point [Method]: >82°C (180°F) [ASTM D-93]

Flammable Limits (Approximate volume % in air): LEL: 0.7 UEL: 7.0 [Estimated]

Autoignition Temperature: >225°C (437°F)

SECTION 6 ACCIDENTAL RELEASE MEASURES

NOTIFICATION PROCEDURES

In the event of a spill or accidental release, notify relevant authorities in accordance with all applicable

regulations. US regulations require reporting releases of this material to the environment which exceed the applicable reportable quantity or oil spills which could reach any waterway including intermittent dry creeks. The National Response Center can be reached at (800)424-8802.

PROTECTIVE MEASURES

Avoid contact with spilled material. Warn or evacuate occupants in surrounding and downwind areas if required due to toxicity or flammability of the material. See Section 5 for fire fighting information. See the Hazard Identification Section for Significant Hazards. See Section 4 for First Aid Advice. See Section 8 for advice on the minimum requirements for personal protective equipment. Additional protective measures may be necessary, depending on the specific circumstances and/or the expert judgment of the emergency responders.

For emergency responders: Respiratory protection: respiratory protection will be necessary only in special cases, e.g., formation of mists. Half-face or full-face respirator with filter(s) for dust/organic vapor or Self Contained Breathing Apparatus (SCBA) can be used depending on the size of spill and potential level of exposure. If the exposure cannot be completely characterized or an oxygen deficient atmosphere is possible or anticipated, SCBA is recommended. Work gloves that are resistant to hydrocarbons are recommended. Gloves made of polyvinyl acetate (PVA) are not water-resistant and are not suitable for emergency use. Chemical goggles are recommended if splashes or contact with eyes is possible. Small spills: normal antistatic work clothes are usually adequate. Large spills: full body suit of chemical resistant, antistatic material is recommended.

SPILL MANAGEMENT

Land Spill: Eliminate all ignition sources (no smoking, flares, sparks or flames in immediate area). Stop leak if you can do it without risk. All equipment used when handling the product must be grounded. Do not touch or walk through spilled material. Prevent entry into waterways, sewer, basements or confined areas. A vapor suppressing foam may be used to reduce vapors. Use clean non-sparking tools to collect absorbed material. Absorb or cover with dry earth, sand or other non-combustible material and transfer to containers. Large Spills: Water spray may reduce vapor; but may not prevent ignition in closed spaces. Recover by pumping or with suitable absorbent.

Water Spill: Stop leak if you can do it without risk. Confine the spill immediately with booms. Warn other shipping. Remove from the surface by skimming or with suitable absorbents. Seek the advice of a specialist before using dispersants.

Water spill and land spill recommendations are based on the most likely spill scenario for this material; however, geographic conditions, wind, temperature, (and in the case of a water spill) wave and current direction and speed may greatly influence the appropriate action to be taken. For this reason, local experts should be consulted. Note: Local regulations may prescribe or limit action to be taken.

ENVIRONMENTAL PRECAUTIONS

Large Spills: Dike far ahead of liquid spill for later recovery and disposal. Prevent entry into waterways, sewers, basements or confined areas.

SECTION 7	HANDLING AND STORAGE
------------------	-----------------------------

HANDLING

Avoid contact with skin. Avoid prolonged breathing of mists and heated vapor. Prevent small spills and leakage to avoid slip hazard. Material can accumulate static charges which may cause an electrical spark (ignition source). When the material is handled in bulk, an electrical spark could ignite any flammable vapors from liquids or residues that may be present (e.g., during switch-loading operations). Use proper bonding and/or ground procedures. However, bonding and grounds may not eliminate the hazard from static

accumulation. Consult local applicable standards for guidance. Additional references include American Petroleum Institute 2003 (Protection Against Ignitions Arising out of Static, Lightning and Stray Currents) or National Fire Protection Agency 77 (Recommended Practice on Static Electricity) or CENELEC CLC/TR 50404 (Electrostatics - Code of practice for the avoidance of hazards due to static electricity).

Static Accumulator: This material is a static accumulator.

STORAGE

The container choice, for example storage vessel, may effect static accumulation and dissipation. Keep container closed. Handle containers with care. Open slowly in order to control possible pressure release. Store in a cool, well-ventilated area. Storage containers should be grounded and bonded. Fixed storage containers, transfer containers and associated equipment should be grounded and bonded to prevent accumulation of static charge.

SECTION 8 EXPOSURE CONTROLS / PERSONAL PROTECTION

EXPOSURE LIMIT VALUES

Exposure limits/standards (Note: Exposure limits are not additive)

Substance Name	Form	Limit / Standard		NOTE	Source
2,6-DI-TERT-BUTYL-P-CRESOL	Inhalable fraction and vapor	TWA	2 mg/m3	N/A	ACGIH
DISTILLATES (PETROLEUM), HYDROTREATED LIGHT [total hydrocarbon vapor]	Non-Aerosol	TWA	200 mg/m3	Skin	ACGIH
HYDROTREATED LIGHT NAPHTHENIC DISTILLATE (PETROLEUM)	Mist.	TWA	5 mg/m3	N/A	OSHA Z1
HYDROTREATED LIGHT NAPHTHENIC DISTILLATE (PETROLEUM)	Inhalable fraction.	TWA	5 mg/m3	N/A	ACGIH
HYDROTREATED LIGHT NAPHTHENIC DISTILLATE (PETROLEUM)	Mist.	TWA	5 mg/m3	N/A	ACGIH
HYDROTREATED MIDDLE DISTILLATE (PETROLEUM)	Mist.	TWA	5 mg/m3	N/A	OSHA Z1
HYDROTREATED MIDDLE DISTILLATE (PETROLEUM)	Inhalable fraction.	TWA	5 mg/m3	N/A	ACGIH
TRIPHENYL PHOSPHATE		TWA	3 mg/m3	N/A	OSHA Z1
TRIPHENYL PHOSPHATE		TWA	3 mg/m3	N/A	ACGIH

Exposure limits/standards for materials that can be formed when handling this product: When mists/aerosols can occur the following are recommended: 5 mg/m³ - ACGIH TLV (inhalable fraction), 5 mg/m³ - OSHA PEL.

NOTE: Limits/standards shown for guidance only. Follow applicable regulations.

No biological limits allocated.

ENGINEERING CONTROLS

The level of protection and types of controls necessary will vary depending upon potential exposure conditions.

Control measures to consider:

Use explosion-proof ventilation equipment to stay below exposure limits.

PERSONAL PROTECTION

Personal protective equipment selections vary based on potential exposure conditions such as applications, handling practices, concentration and ventilation. Information on the selection of protective equipment for use with this material, as provided below, is based upon intended, normal usage.

Respiratory Protection: If engineering controls do not maintain airborne contaminant concentrations at a level which is adequate to protect worker health, an approved respirator may be appropriate. Respirator selection, use, and maintenance must be in accordance with regulatory requirements, if applicable. Types of respirators to be considered for this material include:

No special requirements under ordinary conditions of use and with adequate ventilation.

For high airborne concentrations, use an approved supplied-air respirator, operated in positive pressure mode. Supplied air respirators with an escape bottle may be appropriate when oxygen levels are inadequate, gas/vapor warning properties are poor, or if air purifying filter capacity/rating may be exceeded.

Hand Protection: Any specific glove information provided is based on published literature and glove manufacturer data. Glove suitability and breakthrough time will differ depending on the specific use conditions. Contact the glove manufacturer for specific advice on glove selection and breakthrough times for your use conditions. Inspect and replace worn or damaged gloves. The types of gloves to be considered for this material include:

If prolonged or repeated contact is likely, chemical resistant gloves are recommended. If contact with forearms is likely, wear gauntlet style gloves.

Eye Protection: If contact is likely, safety glasses with side shields are recommended.

Skin and Body Protection: Any specific clothing information provided is based on published literature or manufacturer data. The types of clothing to be considered for this material include:

If prolonged or repeated contact is likely, chemical, and oil resistant clothing is recommended.

Specific Hygiene Measures: Always observe good personal hygiene measures, such as washing after handling the material and before eating, drinking, and/or smoking. Routinely wash work clothing and protective equipment to remove contaminants. Discard contaminated clothing and footwear that cannot be cleaned. Practice good housekeeping.

ENVIRONMENTAL CONTROLS

Comply with applicable environmental regulations limiting discharge to air, water and soil. Protect the environment by applying appropriate control measures to prevent or limit emissions.

SECTION 9

PHYSICAL AND CHEMICAL PROPERTIES

Note: Physical and chemical properties are provided for safety, health and environmental considerations only and may not fully represent product specifications. Contact the Supplier for additional information.

GENERAL INFORMATION

Physical State: Liquid

Color: Red

Product Name: MOBIL AERO HFA
 Revision Date: 01 Oct 2015
 Page 7 of 12

Odor: Characteristic
Odor Threshold: N/D

IMPORTANT HEALTH, SAFETY, AND ENVIRONMENTAL INFORMATION

Relative Density (at 15 °C): 0.88
Flammability (Solid, Gas): N/A
Flash Point [Method]: >82°C (180°F) [ASTM D-93]
Flammable Limits (Approximate volume % in air): LEL: 0.7 UEL: 7.0 [Estimated]
Autoignition Temperature: >225°C (437°F)
Boiling Point / Range: N/D
Decomposition Temperature: N/D
Vapor Density (Air = 1): N/D
Vapor Pressure: [N/D at 20 °C]
Evaporation Rate (n-butyl acetate = 1): N/D
pH: N/A
Log Pow (n-Octanol/Water Partition Coefficient): N/D
Solubility in Water: Negligible
Viscosity: 13.8 cSt (13.8 mm2/sec) at 40 °C | 5.1 cSt (5.1 mm2/sec) at 100°C [ASTM D 445]
Oxidizing Properties: See Hazards Identification Section.

OTHER INFORMATION

Freezing Point: N/D
Melting Point: N/A
Pour Point: -60°C (-76°F) [ASTM D97]
DMSO Extract (mineral oil only), IP-346: < 3 %wt

SECTION 10 STABILITY AND REACTIVITY

REACTIVITY: See sub-sections below.

STABILITY: Material is stable under normal conditions.

CONDITIONS TO AVOID: Open flames and high energy ignition sources.

MATERIALS TO AVOID: Strong oxidizers

HAZARDOUS DECOMPOSITION PRODUCTS: Material does not decompose at ambient temperatures.

POSSIBILITY OF HAZARDOUS REACTIONS: Hazardous polymerization will not occur.

SECTION 11 TOXICOLOGICAL INFORMATION

INFORMATION ON TOXICOLOGICAL EFFECTS

Hazard Class	Conclusion / Remarks
Inhalation	
Acute Toxicity: No end point data for material.	Minimally Toxic. Based on assessment of the components.
Irritation: No end point data for material.	Elevated temperatures or mechanical action may form vapors, mist, or fumes which may be irritating to the eyes, nose, throat, or lungs.

Ingestion	
Acute Toxicity: No end point data for material.	Minimally Toxic. Based on assessment of the components.
Skin	
Acute Toxicity: No end point data for material.	Minimally Toxic. Based on assessment of the components.
Skin Corrosion/Irritation: No end point data for material.	May dry the skin leading to discomfort and dermatitis. Based on assessment of the components.
Eye	
Serious Eye Damage/Irritation: No end point data for material.	May cause mild, short-lasting discomfort to eyes. Based on assessment of the components.
Sensitization	
Respiratory Sensitization: No end point data for material.	Not expected to be a respiratory sensitizer.
Skin Sensitization: No end point data for material.	Not expected to be a skin sensitizer. Based on assessment of the components.
Aspiration: Data available.	May be fatal if swallowed and enters airways. Based on physico-chemical properties of the material.
Germ Cell Mutagenicity: No end point data for material.	Not expected to be a germ cell mutagen. Based on assessment of the components.
Carcinogenicity: No end point data for material.	Not expected to cause cancer. Based on assessment of the components.
Reproductive Toxicity: No end point data for material.	Not expected to be a reproductive toxicant. Based on assessment of the components.
Lactation: No end point data for material.	Not expected to cause harm to breast-fed children.
Specific Target Organ Toxicity (STOT)	
Single Exposure: No end point data for material.	Not expected to cause organ damage from a single exposure.
Repeated Exposure: No end point data for material.	Not expected to cause organ damage from prolonged or repeated exposure. Based on assessment of the components.

TOXICITY FOR SUBSTANCES

NAME	ACUTE TOXICITY
2,6-DI-TERT-BUTYL-P-CRESOL	Oral Lethality: LD50 0.89 g/kg (Rat)

OTHER INFORMATION

For the product itself:

Repeated and/or prolonged exposure may cause irritation to the skin, eyes, or respiratory tract. Small amounts of liquid aspirated into the lungs during ingestion or from vomiting may cause chemical pneumonitis or pulmonary edema.

Contains:

Base oil severely refined: Not carcinogenic in animal studies. Representative material passes IP-346, Modified Ames test, and/or other screening tests. Dermal and inhalation studies showed minimal effects; lung non-specific infiltration of immune cells, oil deposition and minimal granuloma formation. Not sensitizing in test animals.

The following ingredients are cited on the lists below: None.

--REGULATORY LISTS SEARCHED--

Product Name: MOBIL AERO HFA
Revision Date: 01 Oct 2015
Page 9 of 12

1 = NTP CARC
2 = NTP SUS

3 = IARC 1
4 = IARC 2A

5 = IARC 2B
6 = OSHA CARC

SECTION 12 ECOLOGICAL INFORMATION

The information given is based on data available for the material, the components of the material, and similar materials.

ECOTOXICITY

Material -- Not expected to be harmful to aquatic organisms.

MOBILITY

More volatile component -- Highly volatile, will partition rapidly to air. Not expected to partition to sediment and wastewater solids.

Less volatile component -- Low solubility and floats and is expected to migrate from water to the land. Expected to partition to sediment and wastewater solids.

PERSISTENCE AND DEGRADABILITY

Biodegradation:

Components -- Expected to be inherently biodegradable

BIOACCUMULATION POTENTIAL

Majority of components -- Has the potential to bioaccumulate, however metabolism or physical properties may reduce the bioconcentration or limit bioavailability.

SECTION 13 DISPOSAL CONSIDERATIONS

Disposal recommendations based on material as supplied. Disposal must be in accordance with current applicable laws and regulations, and material characteristics at time of disposal.

DISPOSAL RECOMMENDATIONS

Product is suitable for burning in an enclosed controlled burner for fuel value or disposal by supervised incineration at very high temperatures to prevent formation of undesirable combustion products. Protect the environment. Dispose of used oil at designated sites. Minimize skin contact. Do not mix used oils with solvents, brake fluids or coolants.

REGULATORY DISPOSAL INFORMATION

RCRA Information: The unused product, in our opinion, is not specifically listed by the EPA as a hazardous waste (40 CFR, Part 261D), nor is it formulated to contain materials which are listed as hazardous wastes. It does not exhibit the hazardous characteristics of ignitability, corrosivity or reactivity and is not formulated with contaminants as determined by the Toxicity Characteristic Leaching Procedure (TCLP). However, used product may be regulated.

Empty Container Warning Empty Container Warning (where applicable): Empty containers may contain residue and can be dangerous. Do not attempt to refill or clean containers without proper instructions. Empty drums should be

Product Name: MOBIL AERO HFA
Revision Date: 01 Oct 2015
Page 10 of 12

completely drained and safely stored until appropriately reconditioned or disposed. Empty containers should be taken for recycling, recovery, or disposal through suitably qualified or licensed contractor and in accordance with governmental regulations. DO NOT PRESSURISE, CUT, WELD, BRAZE, SOLDER, DRILL, GRIND, OR EXPOSE SUCH CONTAINERS TO HEAT, FLAME, SPARKS, STATIC ELECTRICITY, OR OTHER SOURCES OF IGNITION. THEY MAY EXPLODE AND CAUSE INJURY OR DEATH.

SECTION 14 TRANSPORT INFORMATION

LAND (DOT)

Proper Shipping Name: COMBUSTIBLE LIQUID, N.O.S. (Distillates (Petroleum), Hydrotreated Light)
Hazard Class & Division: COMBUSTIBLE LIQUID
ID Number: NA1993
Packing Group: III
ERG Number: 128
Label(s): NONE
Transport Document Name: NA1993, COMBUSTIBLE LIQUID, N.O.S. (Distillates (Petroleum), Hydrotreated Light), COMBUSTIBLE LIQUID, PG III

Footnote: This material is not regulated under 49 CFR in a container of 119 gallon capacity or less when transported solely by land, as long as the material is not a hazardous waste, a marine pollutant, or specifically listed as a hazardous substance.

LAND (TDG): Not Regulated for Land Transport

SEA (IMDG): Not Regulated for Sea Transport according to IMDG-Code

Marine Pollutant: No

AIR (IATA): Not Regulated for Air Transport

SECTION 15 REGULATORY INFORMATION

OSHA HAZARD COMMUNICATION STANDARD: This material is considered hazardous in accordance with OSHA HazCom 2012, 29 CFR 1910.1200.

Listed or exempt from listing/notification on the following chemical inventories: AICS, DSL, ENCS, IECSC, KECI, PICCS, TCSI, TSCA

EPCRA SECTION 302: This material contains no extremely hazardous substances.

SARA (311/312) REPORTABLE HAZARD CATEGORIES: Fire. Immediate Health. Delayed Health.

SARA (313) TOXIC RELEASE INVENTORY: This material contains no chemicals subject to the supplier notification requirements of the SARA 313 Toxic Release Program.

Product Name: MOBIL AERO HFA
 Revision Date: 01 Oct 2015
 Page 11 of 12

The following ingredients are cited on the lists below:

Chemical Name	CAS Number	List Citations
DISTILLATES (PETROLEUM), HYDROTREATED LIGHT	64742-47-8	1, 17, 18
HYDROTREATED LIGHT NAPHTHENIC DISTILLATE (PETROLEUM)	64742-53-6	1, 4, 13, 17, 18
HYDROTREATED MIDDLE DISTILLATE (PETROLEUM)	64742-46-7	1, 4, 17, 18

--REGULATORY LISTS SEARCHED--

1 = ACGIH ALL	6 = TSCA 5a2	11 = CA P65 REPRO	16 = MN RTK
2 = ACGIH A1	7 = TSCA 5e	12 = CA RTK	17 = NJ RTK
3 = ACGIH A2	8 = TSCA 6	13 = IL RTK	18 = PA RTK
4 = OSHA Z	9 = TSCA 12b	14 = LA RTK	19 = RI RTK
5 = TSCA 4	10 = CA P65 CARC	15 = MI 293	

Code key: CARC=Carcinogen; REPRO=Reproductive

SECTION 16	OTHER INFORMATION
-------------------	--------------------------

N/D = Not determined, N/A = Not applicable

KEY TO THE H-CODES CONTAINED IN SECTION 3 OF THIS DOCUMENT (for information only):

H227: Combustible liquid; Flammable Liquid, Cat 4
 H304: May be fatal if swallowed and enters airways; Aspiration, Cat 1
 H400: Very toxic to aquatic life; Acute Env Tox, Cat 1
 H410: Very toxic to aquatic life with long lasting effects; Chronic Env Tox, Cat 1

THIS SAFETY DATA SHEET CONTAINS THE FOLLOWING REVISIONS:

Revision Changes:

Section 01: Company Mailing Address information was modified.
 Section 05: Hazardous Combustion Products information was modified.
 Section 15: List Citations Table information was modified.
 Section 15: National Chemical Inventory Listing information was modified.
 Section 14: Marine Pollutant information was modified.
 Composition: Component Table information was modified.
 Section 08: Exposure Limits Table information was modified.
 Section 16: Revision Information - Implementation of GHS requirements phrase. information was deleted.

The information and recommendations contained herein are, to the best of ExxonMobil's knowledge and belief, accurate and reliable as of the date issued. You can contact ExxonMobil to insure that this document is the most current available from ExxonMobil. The information and recommendations are offered for the user's consideration and examination. It is the user's responsibility to satisfy itself that the product is suitable for the intended use. If buyer repackages this product, it is the user's responsibility to insure proper health, safety and other necessary information is included with and/or on the container. Appropriate warnings and safe-handling procedures should be provided to handlers and users. Alteration of this document is strictly prohibited. Except to the extent required by law,



Product Name: MOBIL AERO HFA
Revision Date: 01 Oct 2015
Page 12 of 12

re-publication or retransmission of this document, in whole or in part, is not permitted. The term, "ExxonMobil" is used for convenience, and may include any one or more of ExxonMobil Chemical Company, Exxon Mobil Corporation, or any affiliates in which they directly or indirectly hold any interest.

Internal Use Only

MHC: 2A, 0, 0, 0, 1, 1

PPEC: C

DGN: 2005454XUS (552975)

Copyright 2002 Exxon Mobil Corporation, All rights reserved



APPENDIX VII

**Safety Data Sheet (SDS)
MIL-PRF-83282 Hydraulic Fluid**

Section 1. Identification

Product name Brayco Micronic 882
SDS # 451700
Historic SDS #: 27009
Code 451700-US03

Relevant identified uses of the substance or mixture and uses advised against

Product use Hydraulic fluid
For specific application advice see appropriate Technical Data Sheet or consult our company representative.

Supplier Castrol Industrial North America, Inc.
150 W. Warrenville Road
Naperville, IL 60563
Product Information: +1-877-641-1600

BP Lubricants USA Inc.
1500 Valley Road
Wayne, NJ 07470
Telephone: (973) 633-2200

EMERGENCY SPILL INFORMATION: 1 (800) 424-9300 CHEMTREC (USA)

Section 2. Hazards identification

OSHA/HCS status This material is considered hazardous by the OSHA Hazard Communication Standard (29 CFR 1910.1200).

Classification of the substance or mixture ASPIRATION HAZARD - Category 1

GHS label elements

Hazard pictograms



Signal word Danger

Hazard statements May be fatal if swallowed and enters airways.

Precautionary statements

Prevention Not applicable.

Response IF SWALLOWED: Immediately call a POISON CENTER or physician. Do NOT induce vomiting.

Storage Store locked up.

Disposal Dispose of contents and container in accordance with all local, regional, national and international regulations.

Hazards not otherwise classified

Defatting to the skin.
Note: High Pressure Applications
Injections through the skin resulting from contact with the product at high pressure constitute a major medical emergency.
See 'Notes to physician' under First-Aid Measures, Section 4 of this Safety Data Sheet.

Product name Brayco Micronic 882

Product code 451700-US03

Page: 1/9

Version 2 **Date of issue** 03/27/2017.

Format US

Language ENGLISH

(US)

(ENGLISH)

Section 3. Composition/information on ingredients

Substance/mixture Mixture

Synthetic lubricant and additives.

Ingredient name	CAS number	%
1-Decene, homopolymer, hydrogenated	68037-01-4	≥50 - ≤75

Any concentration shown as a range is to protect confidentiality or is due to batch variation.

There are no additional ingredients present which, within the current knowledge of the supplier and in the concentrations applicable, are classified as hazardous to health and hence require reporting in this section.

Occupational exposure limits, if available, are listed in Section 8.

Section 4. First aid measures

Description of necessary first aid measures

Eye contact	In case of contact, immediately flush eyes with plenty of water for at least 15 minutes. Eyelids should be held away from the eyeball to ensure thorough rinsing. Check for and remove any contact lenses. Get medical attention.
Skin contact	Wash skin thoroughly with soap and water or use recognized skin cleanser. Remove contaminated clothing and shoes. Wash clothing before reuse. Clean shoes thoroughly before reuse. Get medical attention if symptoms occur.
Inhalation	If inhaled, remove to fresh air. Get medical attention if symptoms occur.
Ingestion	Do not induce vomiting. Never give anything by mouth to an unconscious person. If unconscious, place in recovery position and get medical attention immediately. Aspiration hazard if swallowed. Can enter lungs and cause damage. Get medical attention immediately.
Protection of first-aiders	No action shall be taken involving any personal risk or without suitable training. It may be dangerous to the person providing aid to give mouth-to-mouth resuscitation.

Most important symptoms/effects, acute and delayed

See Section 11 for more detailed information on health effects and symptoms.

Indication of immediate medical attention and special treatment needed, if necessary

Notes to physician	1 Treatment should in general be symptomatic and directed to relieving any effects. Product can be aspirated on swallowing or following regurgitation of stomach contents, and can cause severe and potentially fatal chemical pneumonitis, which will require urgent treatment. Because of the risk of aspiration, induction of vomiting and gastric lavage should be avoided. Gastric lavage should be undertaken only after endotracheal intubation. Monitor for cardiac dysrhythmias.
---------------------------	---

Note: High Pressure Applications
Injections through the skin resulting from contact with the product at high pressure constitute a major medical emergency. Injuries may not appear serious at first but within a few hours tissue becomes swollen, discolored and extremely painful with extensive subcutaneous necrosis.
Surgical exploration should be undertaken without delay. Thorough and extensive debridement of the wound and underlying tissue is necessary to minimize tissue loss and prevent or limit permanent damage. Note that high pressure may force the product considerable distances along tissue planes.

Specific treatments	No specific treatment.
----------------------------	------------------------

Section 5. Fire-fighting measures

Extinguishing media

Suitable extinguishing media	In case of fire, use foam, dry chemical or carbon dioxide extinguisher or spray.
Unsuitable extinguishing media	Do not use water jet.

Product name Brayco Micronic 882

Product code 451700-US03

Page: 2/9

Version 2 **Date of issue** 03/27/2017.

Format US
(US)

Language ENGLISH
(ENGLISH)

Section 5. Fire-fighting measures

Specific hazards arising from the chemical	In a fire or if heated, a pressure increase will occur and the container may burst.
Hazardous combustion products	Combustion products may include the following: carbon dioxide carbon monoxide
Special protective actions for fire-fighters	Promptly isolate the scene by removing all persons from the vicinity of the incident if there is a fire. No action shall be taken involving any personal risk or without suitable training.
Special protective equipment for fire-fighters	Fire-fighters should wear positive pressure self-contained breathing apparatus (SCBA) and full turnout gear.

Section 6. Accidental release measures

Personal precautions, protective equipment and emergency procedures

For non-emergency personnel	No action shall be taken involving any personal risk or without suitable training. Evacuate surrounding areas. Keep unnecessary and unprotected personnel from entering. Do not touch or walk through spilled material. Avoid breathing vapor or mist. Provide adequate ventilation. Put on appropriate personal protective equipment. Floors may be slippery; use care to avoid falling. Contact emergency personnel.
For emergency responders	Entry into a confined space or poorly ventilated area contaminated with vapor, mist or fume is extremely hazardous without the correct respiratory protective equipment and a safe system of work. Wear self-contained breathing apparatus. Wear a suitable chemical protective suit. Chemical resistant boots. See also the information in "For non-emergency personnel".
Environmental precautions	Avoid dispersal of spilled material and runoff and contact with soil, waterways, drains and sewers. Inform the relevant authorities if the product has caused environmental pollution (sewers, waterways, soil or air).

Methods and materials for containment and cleaning up

Small spill	Stop leak if without risk. Move containers from spill area. Absorb with an inert material and place in an appropriate waste disposal container. Dispose of via a licensed waste disposal contractor.
Large spill	Stop leak if without risk. Move containers from spill area. Approach release from upwind. Prevent entry into sewers, water courses, basements or confined areas. Contain and collect spillage with non-combustible, absorbent material e.g. sand, earth, vermiculite or diatomaceous earth and place in container for disposal according to local regulations. Contaminated absorbent material may pose the same hazard as the spilled product. Dispose of via a licensed waste disposal contractor.

Section 7. Handling and storage

Precautions for safe handling

Protective measures	Put on appropriate personal protective equipment (see Section 8). Avoid breathing vapor or mist. Avoid contact with eyes, skin and clothing. Empty containers retain product residue and can be hazardous. Keep in the original container or an approved alternative made from a compatible material, kept tightly closed when not in use. Do not reuse container. Do not swallow. Aspiration hazard if swallowed. Can enter lungs and cause damage. Never siphon by mouth.
Advice on general occupational hygiene	Eating, drinking and smoking should be prohibited in areas where this material is handled, stored and processed. Wash thoroughly after handling. Remove contaminated clothing and protective equipment before entering eating areas. See also Section 8 for additional information on hygiene measures.

Product name	Brayco Micronic 882	Product code	451700-US03	Page:	3/9
Version	2	Date of issue	03/27/2017.	Format	US (US)
				Language	ENGLISH (ENGLISH)

Section 7. Handling and storage

Conditions for safe storage, including any incompatibilities

Store in accordance with local regulations. Store in original container protected from direct sunlight in a dry, cool and well-ventilated area, away from incompatible materials (see Section 10) and food and drink. Store locked up. Keep container tightly closed and sealed until ready for use. Store and use only in equipment/containers designed for use with this product. Containers that have been opened must be carefully resealed and kept upright to prevent leakage. Do not store in unlabeled containers. Use appropriate containment to avoid environmental contamination.

Section 8. Exposure controls/personal protection

Control parameters

Occupational exposure limits

Decene, homopolymer, hydrogenated

None.

Appropriate engineering controls

All activities involving chemicals should be assessed for their risks to health, to ensure exposures are adequately controlled. Personal protective equipment should only be considered after other forms of control measures (e.g. engineering controls) have been suitably evaluated. Personal protective equipment should conform to appropriate standards, be suitable for use, be kept in good condition and properly maintained. Your supplier of personal protective equipment should be consulted for advice on selection and appropriate standards. For further information contact your national organisation for standards.

Provide exhaust ventilation or other engineering controls to keep the relevant airborne concentrations below their respective occupational exposure limits.

The final choice of protective equipment will depend upon a risk assessment. It is important to ensure that all items of personal protective equipment are compatible.

Environmental exposure controls

Emissions from ventilation or work process equipment should be checked to ensure they comply with the requirements of environmental protection legislation. In some cases, fume scrubbers, filters or engineering modifications to the process equipment will be necessary to reduce emissions to acceptable levels.

Individual protection measures

Hygiene measures

Wash hands, forearms and face thoroughly after handling chemical products, before eating, smoking and using the lavatory and at the end of the working period. Appropriate techniques should be used to remove potentially contaminated clothing. Wash contaminated clothing before reusing. Ensure that eyewash stations and safety showers are close to the workstation location.

Eye/face protection

Safety glasses with side shields.

Skin protection

Hand protection

Wear protective gloves if prolonged or repeated contact is likely. Wear chemical resistant gloves. Recommended: Nitrile gloves. The correct choice of protective gloves depends upon the chemicals being handled, the conditions of work and use, and the condition of the gloves (even the best chemically resistant glove will break down after repeated chemical exposures). Most gloves provide only a short time of protection before they must be discarded and replaced. Because specific work environments and material handling practices vary, safety procedures should be developed for each intended application. Gloves should therefore be chosen in consultation with the supplier/manufacturer and with a full assessment of the working conditions.

Body protection

Use of protective clothing is good industrial practice. Cotton or polyester/cotton overalls will only provide protection against light superficial contamination that will not soak through to the skin. Overalls should be laundered on a regular basis. When the risk of skin exposure is high (e.g. when cleaning up spillages or if there is a risk of splashing) then chemical resistant aprons and/or impervious chemical suits and boots will be required. Personal protective equipment for the body should be selected based on the task being performed and the risks involved and should be approved by a specialist before handling this product.

Other skin protection

Appropriate footwear and any additional skin protection measures should be selected based on the task being performed and the risks involved and should be approved by a specialist before handling this product.

Product name Brayco Micronic 882

Product code 451700-US03

Page: 4/9

Version 2 **Date of issue** 03/27/2017.

Format US

Language ENGLISH

(US)

(ENGLISH)

Section 8. Exposure controls/personal protection

Respiratory protection

In case of insufficient ventilation, wear suitable respiratory equipment. The correct choice of respiratory protection depends upon the chemicals being handled, the conditions of work and use, and the condition of the respiratory equipment. Safety procedures should be developed for each intended application. Respiratory protection equipment should therefore be chosen in consultation with the supplier/manufacturer and with a full assessment of the working conditions.

Section 9. Physical and chemical properties

Appearance

Physical state	Liquid.
Color	Red. [Dark]
Odor	Mild.
Odor threshold	Not available.
pH	Not available.
Melting point	Not available.
Boiling point	Not available.
Flash point	Open cup: 205°C (401°F) [Cleveland.]
Pour point	55 °C
Evaporation rate	Not available.
Flammability (solid, gas)	Not applicable. Based on - Physical state
Lower and upper explosive (flammable) limits	Not available.
Vapor pressure	Not available.
Vapor density	Not available.
Density	<1000 kg/m ³ (<1 g/cm ³) at 15°C
Solubility	insoluble in water.
Partition coefficient: n-octanol/water	Not available.
Auto-ignition temperature	Not available.
Decomposition temperature	Not available.
Viscosity	Kinematic: 14 mm ² /s (14 cSt) at 40°C

Section 10. Stability and reactivity

Reactivity	No specific test data available for this product. Refer to Conditions to avoid and Incompatible materials for additional information.
Chemical stability	The product is stable.
Possibility of hazardous reactions	Under normal conditions of storage and use, hazardous reactions will not occur. Under normal conditions of storage and use, hazardous polymerization will not occur.
Conditions to avoid	No specific data.
Incompatible materials	Reactive or incompatible with the following materials: oxidizing materials.
Hazardous decomposition products	Under normal conditions of storage and use, hazardous decomposition products should not be produced.

Product name Brayco Micronic 882

Product code 451700-US03

Page: 5/9

Version 2 Date of issue 03/27/2017.

Format US

Language ENGLISH

(US)

(ENGLISH)

Section 11. Toxicological information

Information on toxicological effects

Aspiration hazard

Name	Result
 Decene, homopolymer, hydrogenated	ASPIRATION HAZARD - Category 1

Information on the likely routes of exposure Routes of entry anticipated: Dermal, Inhalation.

Potential acute health effects

Eye contact	No known significant effects or critical hazards.
Skin contact	No known significant effects or critical hazards.
Inhalation	Vapor inhalation under ambient conditions is not normally a problem due to low vapor pressure.
Ingestion	Aspiration hazard if swallowed -- harmful or fatal if liquid is aspirated into lungs.

Symptoms related to the physical, chemical and toxicological characteristics

Eye contact	No specific data.
Skin contact	Adverse symptoms may include the following: irritation dryness cracking
Inhalation	No specific data.
Ingestion	Adverse symptoms may include the following: nausea or vomiting

Delayed and immediate effects and also chronic effects from short and long term exposure

Short term exposure

Potential immediate effects	Not available.
Potential delayed effects	Not available.

Long term exposure

Potential immediate effects	Not available.
Potential delayed effects	Not available.

Potential chronic health effects

General	No known significant effects or critical hazards.
Carcinogenicity	No known significant effects or critical hazards.
Mutagenicity	No known significant effects or critical hazards.
Teratogenicity	No known significant effects or critical hazards.
Developmental effects	No known significant effects or critical hazards.
Fertility effects	No known significant effects or critical hazards.

Numerical measures of toxicity

Acute toxicity estimates

Not available.

Product name Brayco Micronic 882	Product code 451700-US03	Page: 6/9
Version 2	Date of issue 03/27/2017.	Format US
		Language ENGLISH
	(US)	(ENGLISH)

Section 12. Ecological information

Toxicity

No testing has been performed by the manufacturer.

Persistence and degradability

Not expected to be rapidly degradable.

Bioaccumulative potential

Not available.

Mobility in soil

Soil/water partition
coefficient (K_{oc})

Not available.

Mobility

Non-volatile.Liquid.insoluble in water.

Other adverse effects

No known significant effects or critical hazards.

Section 13. Disposal considerations

Disposal methods

The generation of waste should be avoided or minimized wherever possible. Significant quantities of waste product residues should not be disposed of via the foul sewer but processed in a suitable effluent treatment plant. Dispose of surplus and non-recyclable products via a licensed waste disposal contractor. Disposal of this product, solutions and any by-products should at all times comply with the requirements of environmental protection and waste disposal legislation and any regional local authority requirements. Waste packaging should be recycled. Incineration or landfill should only be considered when recycling is not feasible. This material and its container must be disposed of in a safe way. Care should be taken when handling emptied containers that have not been cleaned or rinsed out. Empty containers or liners may retain some product residues. Avoid dispersal of spilled material and runoff and contact with soil, waterways, drains and sewers.

Section 14. Transport information

	DOT Classification	TDG Classification	IMDG	IATA
UN number	Not regulated.	Not regulated.	Not regulated.	Not regulated.
UN proper shipping name	-	-	-	-
Transport hazard class(es)	-	-	-	-
Packing group	-	-	-	-
Environmental hazards	No.	No.	No.	No.
Additional information	-	-	-	-

Special precautions for user Not available.

Transport in bulk according to Annex II of MARPOL and the IBC Code Not available.

Product name	Brayco Micronic 882	Product code	451700-US03	Page: 7/9
Version	2	Date of issue	03/27/2017.	Format
				US
				(US)
				Language
				ENGLISH
				(ENGLISH)

Section 15. Regulatory information

U.S. Federal regulations

United States inventory (TSCA 8b) All components are listed or exempted.

TSCA 12(b) one-time export: 2,2',6,6'-tetra-tert-butyl-4,4'-methylenediphenol

SARA 302/304

Composition/Information on ingredients

No products were found.

SARA 311/312

Classification Not applicable.

SARA 313

Form R - Reporting requirements This product does not contain any hazardous ingredients at or above regulated thresholds.

Supplier notification This product does not contain any hazardous ingredients at or above regulated thresholds.

State regulations

Massachusetts None of the components are listed.

New Jersey None of the components are listed.

Pennsylvania None of the components are listed.

California Prop. 65 No products were found.

Other regulations

Australia inventory (AICS) All components are listed or exempted.

Canada inventory All components are listed or exempted.

China inventory (IECSC) All components are listed or exempted.

Japan inventory (ENCS) All components are listed or exempted.

Korea inventory (KECI) All components are listed or exempted.

Philippines inventory (PICCS) All components are listed or exempted.

Taiwan Chemical Substances Inventory (TCSI) Not determined.

REACH Status The company, as identified in Section 1, sells this product in the EU in compliance with the current requirements of REACH.

Section 16. Other information

National Fire Protection Association (U.S.A.)



History

Date of issue/Date of revision 03/27/2017.

Date of previous issue 11/22/2016.

Prepared by Product Stewardship

Key to abbreviations

ACGIH = American Conference of Industrial Hygienists
ATE = Acute Toxicity Estimate
BCF = Bioconcentration Factor
CAS Number = Chemical Abstracts Service Registry Number
GHS = Globally Harmonized System of Classification and Labelling of Chemicals
IATA = International Air Transport Association
IBC = Intermediate Bulk Container

Product name Brayco Micronic 882	Product code 451700-US03	Page: 8/9	
Version 2	Date of issue 03/27/2017.	Format US	Language ENGLISH
		(US)	(ENGLISH)

Section 16. Other information

IMDG = International Maritime Dangerous Goods
LogPow = logarithm of the octanol/water partition coefficient
MARPOL = International Convention for the Prevention of Pollution From Ships, 1973 as modified by the Protocol of 1978. ("Marpol" = marine pollution)
OEL = Occupational Exposure Limit
SDS = Safety Data Sheet
STEL = Short term exposure limit
TWA = Time weighted average
UN = United Nations
UN Number = United Nations Number, a four digit number assigned by the United Nations Committee of Experts on the Transport of Dangerous Goods.
Varies = may contain one or more of the following 101316-69-2, 101316-70-5, 101316-71-6, 101316-72-7, 64741-88-4, 64741-89-5, 64741-95-3, 64741-96-4, 64741-97-5, 64742-01-4, 64742-44-5, 64742-45-6, 64742-52-5, 64742-53-6, 64742-54-7, 64742-55-8, 64742-56-9, 64742-57-0, 64742-58-1, 64742-62-7, 64742-63-8, 64742-64-9, 64742-65-0, 64742-70-7, 72623-85-9, 72623-86-0, 72623-87-1, 74869-22-0, 90669-74-2

✔ Indicates information that has changed from previously issued version.

[Notice to reader](#)

All reasonably practicable steps have been taken to ensure this data sheet and the health, safety and environmental information contained in it is accurate as of the date specified below. No warranty or representation, express or implied is made as to the accuracy or completeness of the data and information in this data sheet.

The data and advice given apply when the product is sold for the stated application or applications. You should not use the product other than for the stated application or applications without seeking advice from BP Group.

It is the user's obligation to evaluate and use this product safely and to comply with all applicable laws and regulations. The BP Group shall not be responsible for any damage or injury resulting from use, other than the stated product use of the material, from any failure to adhere to recommendations, or from any hazards inherent in the nature of the material. Purchasers of the product for supply to a third party for use at work, have a duty to take all necessary steps to ensure that any person handling or using the product is provided with the information in this sheet. Employers have a duty to tell employees and others who may be affected of any hazards described in this sheet and of any precautions that should be taken. You can contact the BP Group to ensure that this document is the most current available. Alteration of this document is strictly prohibited.

Product name	Brayco Micronic 882	Product code	451700-US03	Page: 9/9
Version 2	Date of issue 03/27/2017.	Format US (US)	Language ENGLISH (ENGLISH)	



APPENDIX VIII

Safety Data Sheet (SDS) Aviation Phosphate Ester, Type IV and V Hydraulic Fluid

Skydrol® LD4 Fire Resistant Hydraulic Fluid

Version Revision Date: SDS Number: Date of last issue: 06/02/2015
2.2 08/09/2016 150000093409 Date of first issue: 10/24/2013
SDSUS / PRD / 0001

SECTION 1. IDENTIFICATION

Product name : Skydrol® LD4 Fire Resistant Hydraulic Fluid

Product code : P3410201

Manufacturer or supplier's details

Company name of supplier : Eastman Chemical Company

Address : 200 South Wilcox Drive
 : Kingsport TN 37660-5280

Telephone : (423) 229-2000

Emergency telephone number : CHEMTREC: +1-800-424-9300, +1-703-527-3887 CCN7321
 : For emergency transportation information, in the United States:
 : call CHEMTREC at 800-424-9300 or call 423-229-2000.

Recommended use of the chemical and restrictions on use

Recommended use : Hydraulic fluids

Restrictions on use : None known.

SECTION 2. HAZARDS IDENTIFICATION**GHS Classification**

Skin irritation : Category 2

Carcinogenicity : Category 2

GHS label elements

Hazard pictograms : 

Signal word : Warning

Hazard statements : H315 Causes skin irritation.
 : H351 Suspected of causing cancer.

Precautionary statements : **Prevention:**
 : P201 Obtain special instructions before use.
 : P202 Do not handle until all safety precautions have been read
 : and understood.
 : P264 Wash skin thoroughly after handling.
 : P280 Wear protective gloves/ protective clothing/ eye protection/
 : face protection.

Skydrol® LD4 Fire Resistant Hydraulic Fluid

Version Revision Date: SDS Number: Date of last issue: 06/02/2015
 2.2 08/09/2016 150000093409 Date of first issue: 10/24/2013
 SDSUS / PRD / 0001

Response:

P302 + P352 IF ON SKIN: Wash with plenty of soap and water.
 P308 + P313 IF exposed or concerned: Get medical advice/
 attention.

P332 + P313 If skin irritation occurs: Get medical advice/
 attention.

P362 Take off contaminated clothing and wash before reuse.

Storage:

P405 Store locked up.

Disposal:

P501 Dispose of contents/ container to an approved waste disposal plant.

Other hazards

None known.

SECTION 3. COMPOSITION/INFORMATION ON INGREDIENTS**Components**

Chemical name	CAS-No.	Concentration (% w/w)
Tributyl phosphate	126-73-8	55 - 65
Dibutylphenylphosphate	2528-36-1	20 - 30
Butyl diphenyl phosphate	2752-95-6	5 - 10
7-Oxabicyclo[4.1.0]heptane-3-carboxylic acid, 2-ethylhexyl ester	62256-00-2	< 10
butylated hydroxytoluene	128-37-0	1

SECTION 4. FIRST AID MEASURES

- If inhaled : Move to fresh air.
 If breathing is difficult, give oxygen.
 Consult a physician if necessary.
- In case of skin contact : Wash off immediately with plenty of water for at least 15 minutes.
 Get medical attention if symptoms occur.
 Wash contaminated clothing before reuse.
- In case of eye contact : In case of contact, immediately flush eyes with plenty of water for at least 15 minutes.
 Get medical attention if symptoms occur.
- If swallowed : Call a physician or poison control centre immediately.
 Do not induce vomiting without medical advice.
 Rinse mouth.
 Never give anything by mouth to an unconscious person.
- Most important symptoms and effects, both acute and delayed : Causes skin irritation.
 Suspected of causing cancer.

Skydrol® LD4 Fire Resistant Hydraulic Fluid

Version Revision Date: SDS Number: Date of last issue: 06/02/2015
 2.2 08/09/2016 150000093409 Date of first issue: 10/24/2013
 SDSUS / PRD / 0001

Wash thoroughly after handling.
 Wash contaminated clothing before reuse.
 Drain or remove substance from equipment prior to break-in or maintenance.
 Handle in accordance with good industrial hygiene and safety practice.

Conditions for safe storage : Store locked up.
 Keep container tightly closed in a dry and well-ventilated place.
 Keep in a cool place away from oxidizing agents.

SECTION 8. EXPOSURE CONTROLS/PERSONAL PROTECTION**Components with workplace control parameters**

Components	CAS-No.	Value type (Form of exposure)	Control parameters / Permissible concentration	Basis
Tributyl phosphate	126-73-8	TWA (Inhalable fraction and vapor)	5 mg/m ³	ACGIH
		TWA	0.2 ppm 2.5 mg/m ³	NIOSH REL
		TWA	5 mg/m ³	OSHA Z-1
		TWA	0.2 ppm 2.5 mg/m ³	OSHA P0
Dibutylphenylphosphate	2528-36-1	TWA	0.3 ppm	ACGIH
butylated hydroxytoluene	128-37-0	TWA (Inhalable fraction and vapor)	2 mg/m ³	ACGIH
		TWA	10 mg/m ³	NIOSH REL
		TWA	10 mg/m ³	OSHA P0

Hazardous components without workplace control parameters

Components	CAS-No.
7-Oxabicyclo[4.1.0]heptane-3-carboxylic acid, 2-ethylhexyl ester	62256-00-2

Engineering measures : Good general ventilation (typically 10 air changes per hour) should be used. Ventilation rates should be matched to conditions. If applicable, use process enclosures, local exhaust ventilation, or other engineering controls to maintain airborne levels below recommended exposure limits. If exposure limits have not been established, maintain airborne levels to an acceptable level.

Personal protective equipment

Respiratory protection : Use a properly fitted, particulate filter respirator complying with an approved standard if a risk assessment indicates this is necessary.

Skydrol® LD4 Fire Resistant Hydraulic Fluid

Version	Revision Date:	SDS Number:	Date of last issue: 06/02/2015
2.2	08/09/2016	150000093409	Date of first issue: 10/24/2013

SDSUS / PRD / 0001

Respirator selection, use, and maintenance must be in accordance with regulatory requirements, if applicable. If engineering controls do not maintain airborne concentrations below recommended exposure limits (where applicable) or to an acceptable level (in countries where exposure limits have not been established), an approved respirator must be worn.

Hand protection

Remarks : Wear suitable gloves. Please observe the instructions regarding permeability and breakthrough time which are provided by the supplier of the gloves. Also take into consideration the specific local conditions under which the product is used, such as the danger of cuts, abrasion, and the contact time. After contamination with product change the gloves immediately and dispose of them according to relevant national and local regulations.

Eye protection : Wear safety glasses with side shields (or goggles).

Skin and body protection : Wear suitable protective clothing.

Protective measures : Ensure that eye flushing systems and safety showers are located close to the working place.

SECTION 9. PHYSICAL AND CHEMICAL PROPERTIES

Appearance	: oily
Colour	: purple
Odour	: odourless
pH	: No data available
Melting point/range	: < -62 °C
Flash point	: 160 °C Method: Cleveland open cup
Vapour pressure	: 0.27 hPa (25 °C)
Relative density	: 1.004 - 1.014 (25 °C)
Viscosity	
Viscosity, kinematic	: < 2000 mm ² /s (-54 °C)
	11.15 mm ² /s (38 °C)
	3.83 mm ² /s (99 °C)

Skydrol® LD4 Fire Resistant Hydraulic Fluid

Version 2.2 Revision Date: 08/09/2016 SDS Number: 150000093409 Date of last issue: 06/02/2015
Date of first issue: 10/24/2013
SDSUS / PRD / 0001

SECTION 10. STABILITY AND REACTIVITY

- Reactivity : None reasonably foreseeable.
- Chemical stability : Stable under normal conditions.
- Possibility of hazardous reactions : None known.
- Conditions to avoid : None known.
- Incompatible materials : Strong oxidizing agents
- Hazardous decomposition products : Emits acrid smoke and fumes when heated to decomposition.
-

SECTION 11. TOXICOLOGICAL INFORMATION**Acute toxicity**

Not classified based on available information.

Product:

- Acute oral toxicity : LD50 (Rat, Male and Female): 2,100 mg/kg
- Acute inhalation toxicity : LC50 (Rat, male): > 5.8 mg/l
Exposure time: 4 h
Test atmosphere: dust/mist
Assessment: The substance or mixture has no acute inhalation toxicity
Remarks: (highest concentration tested)
- Acute dermal toxicity : LD50 Dermal (Rabbit, Male and Female): > 3,160 mg/kg
Assessment: The substance or mixture has no acute dermal toxicity

Components:**Tributyl phosphate:**

- Acute oral toxicity : LD50 Oral (Rat, Male and Female): 1,553 mg/kg
Method: Acute Oral Toxicity
Assessment: Harmful if swallowed.
- Acute inhalation toxicity : LC50 (Rat, Male and Female): > 4.242 mg/l
Exposure time: 4 h
Test atmosphere: dust/mist
Assessment: The substance or mixture has no acute inhalation toxicity
- Acute dermal toxicity : LD50 Dermal (Rabbit, Male and Female): > 3,100 mg/kg
Assessment: The substance or mixture has no acute dermal toxicity

Dibutylphenylphosphate:

Skydrol® LD4 Fire Resistant Hydraulic Fluid

Version Revision Date: SDS Number: Date of last issue: 06/02/2015
2.2 08/09/2016 150000093409 Date of first issue: 10/24/2013
SDSUS / PRD / 0001

Acute oral toxicity : Acute toxicity estimate (Rat, Male and Female): 2,400 - 3,000 mg/kg
Assessment: Not classified

Acute inhalation toxicity : LCLo (Rat, Male and Female): > 5 mg/l
Exposure time: 4 h
Test atmosphere: dust/mist

LC50 (Rat, Male and Female): > 5 mg/l
Exposure time: 4 h
Test atmosphere: dust/mist
Assessment: Not classified

Acute dermal toxicity : LD50 Dermal (Rabbit, Male and Female): > 5,000 mg/kg
Assessment: Not classified

7-Oxabicyclo[4.1.0]heptane-3-carboxylic acid, 2-ethylhexyl ester:

Acute oral toxicity : LD50 Oral (Rat, Male and Female): 4,470 mg/kg

Acute dermal toxicity : LD50 Dermal (Rabbit, Male and Female): > 7,940 mg/kg

butylated hydroxytoluene:

Acute oral toxicity : LD50 Oral (Rat): > 6,000 mg/kg

Acute dermal toxicity : LD50 Dermal (Guinea pig): > 20,000 mg/kg

Skin corrosion/irritation

Causes skin irritation.

Product:

Species: Rabbit
Exposure time: 24 h
Assessment: irritating
Result: moderate irritation

Components:**Tributyl phosphate:**

Species: Rabbit
Exposure time: 4 h
Assessment: Causes skin irritation.
Method: Acute Dermal Irritation / Corrosion
Result: irritating

Dibutylphenylphosphate:

Species: Rabbit
Assessment: Not classified

Species: Humans
Exposure time: 24 h
Assessment: Not classified

7-Oxabicyclo[4.1.0]heptane-3-carboxylic acid, 2-ethylhexyl ester:

Species: Rabbit

Skydrol® LD4 Fire Resistant Hydraulic Fluid

Version 2.2 Revision Date: 08/09/2016 SDS Number: 150000093409 Date of last issue: 06/02/2015
Date of first issue: 10/24/2013
SDSUS / PRD / 0001

Exposure time: 24 h
Assessment: Not classified as hazardous.
Result: slight to moderate irritation

butylated hydroxytoluene:

Species: Rabbit
Exposure time: 24 h
Result: very slight

Serious eye damage/eye irritation

Not classified based on available information.

Product:

Species: Rabbit
Result: slight
Exposure time: 24 h
Assessment: Not classified

Components:**Tributyl phosphate:**

Species: Rabbit
Result: slight irritation
Exposure time: 24 h
Assessment: Not classified
Method: Acute Eye Irritation / Corrosion

Dibutylphenylphosphate:

Species: Rabbit
Result: slight
Assessment: Not classified

7-Oxabicyclo[4.1.0]heptane-3-carboxylic acid, 2-ethylhexyl ester:

Species: Rabbit
Result: slight irritation
Exposure time: 24 h
Assessment: Not classified

butylated hydroxytoluene:

Species: Rabbit
Result: none

Respiratory or skin sensitisation

Skin sensitisation: Not classified based on available information.
Respiratory sensitisation: Not classified based on available information.

Product:

Test Type: Human experience
Assessment: Not classified
Method: Human Repeat Insult Patch Test
Result: Does not cause skin sensitisation.

Components:

Skydrol® LD4 Fire Resistant Hydraulic Fluid

Version Revision Date: SDS Number: Date of last issue: 06/02/2015
 2.2 08/09/2016 150000093409 Date of first issue: 10/24/2013
 SDSUS / PRD / 0001

Tributyl phosphate:

Test Type: Skin Sensitization
 Species: Guinea pig
 Assessment: Not classified
 Result: Does not cause skin sensitisation.

Test Type: Skin Sensitization
 Species: Humans
 Assessment: Not classified
 Result: Does not cause skin sensitisation.

Dibutylphenylphosphate:

Test Type: Human experience
 Species: Humans
 Assessment: Not classified
 Result: non-sensitizing

7-Oxabicyclo[4.1.0]heptane-3-carboxylic acid, 2-ethylhexyl ester:

Test Type: Skin Sensitization
 Species: Guinea pig
 Result: May cause sensitisation by skin contact.

butylated hydroxytoluene:

Test Type: Skin sensitisation
 Species: Guinea pig
 Result: non-sensitizing

Germ cell mutagenicity

Not classified based on available information.

Product:

Genotoxicity in vitro : Test Type: Salmonella typhimurium assay (Ames test)
 Metabolic activation: +/- activation
 Result: negative

: Test Type: Mutagenicity - Mammalian
 Metabolic activation: +/- activation
 Method: In vitro Mammalian Chromosome Aberration Test
 Result: negative

Components:**Tributyl phosphate:**

Genotoxicity in vitro : Test Type: Mutagenicity - Bacterial
 Metabolic activation: +/- activation
 Method: Bacterial Reverse Mutation Assay
 Result: negative

: Test Type: Mutagenicity - Mammalian
 Metabolic activation: +/- activation
 Method: In vitro Mammalian Chromosome Aberration Test
 Result: equivocal

Genotoxicity in vivo : Species: Rat (Male and Female)

Skydrol® LD4 Fire Resistant Hydraulic Fluid

Version Revision Date: SDS Number: Date of last issue: 06/02/2015
 2.2 08/09/2016 150000093409 Date of first issue: 10/24/2013
 SDSUS / PRD / 0001

Application Route: oral: gavage
 Method: Mammalian Bone Marrow Chromosome Aberration Test
 Result: negative

Dibutylphenylphosphate:

Genotoxicity in vitro

: Test Type: Salmonella typhimurium assay (Ames test)
 Metabolic activation: +/- activation
 Method: Bacterial Reverse Mutation Assay
 Result: negative

: Test Type: Mutagenicity - Mammalian
 Metabolic activation: +/- activation
 Method: In vitro Mammalian Cell Gene Mutation Test
 Result: negative

: Test Type: Chromosome aberration test in vitro
 Metabolic activation: +/- activation
 Method: In vitro Mammalian Chromosome Aberration Test
 Result: negative

: Test Type: Mutagenicity - Mammalian
 Metabolic activation: - activation
 Method: Genetic Toxicology: DNA Damage and Repair, Un-scheduled DNA Synthesis in Mammalian Cells In Vitro
 Result: negative

Genotoxicity in vivo

: Species: Rat (Male and Female)
 Application Route: intraperitoneal injection
 Result: negative

7-Oxabicyclo[4.1.0]heptane-3-carboxylic acid, 2-ethylhexyl ester:

Genotoxicity in vitro

: Test Type: Salmonella typhimurium assay (Ames test)
 Metabolic activation: +/- activation
 Method: Bacterial Reverse Mutation Assay
 Result: negative

: Test Type: Mutagenicity - Mammalian
 Metabolic activation: +/- activation
 Method: In vitro Mammalian Chromosome Aberration Test
 Result: equivocal

: Test Type: Mutagenicity - Mammalian
 Metabolic activation: +/- activation
 Method: In vitro Mammalian Cell Gene Mutation Test
 Result: negative

Genotoxicity in vivo

: Species: Rat (Male and Female)
 Application Route: intraperitoneal injection
 Method: Mammalian Bone Marrow Chromosome Aberration Test
 Result: equivocal

Skydrol® LD4 Fire Resistant Hydraulic Fluid

Version Revision Date: SDS Number: Date of last issue: 06/02/2015
 2.2 08/09/2016 150000093409 Date of first issue: 10/24/2013
 SDSUS / PRD / 0001

Carcinogenicity

Suspected of causing cancer.

Components:**Tributyl phosphate:**

Species: Rat, (Male and Female)
 Application Route: Ingestion
 Method: EPA OTS 798.3300
 Remarks: Limited evidence of a carcinogenic effect.
 May cause cancer.

IARC

No component of this product present at levels greater than or equal to 0.1% is identified as probable, possible or confirmed human carcinogen by IARC.

OSHA

No component of this product present at levels greater than or equal to 0.1% is identified as a carcinogen or potential carcinogen by OSHA.

NTP

No component of this product present at levels greater than or equal to 0.1% is identified as a known or anticipated carcinogen by NTP.

Reproductive toxicity

Not classified based on available information.

Components:**Tributyl phosphate:**

Effects on fertility :
 : Test Type: Two Generation Reproductive Toxicity Study
 Species: Rat
 Sex: Male and Female
 Application Route: Ingestion
 NOAEL: 225 mg/kg,
 Method: EPA OTS 798.4900

Effects on foetal development : Species: Rat
 Application Route: Oral
 750 mg/kg
 Method: EPA OTS 798.4900

Dibutylphenylphosphate:

Effects on fertility :
 : Species: Rat
 Sex: Male and Female
 Application Route: Ingestion
 NOAEL: 5 mg/l,
 F1: Lowest observed adverse effect level 50 mg/kg,
 F2: Lowest observed adverse effect level 50 mg/kg,
 Method: EPA OTS 798.4900

Effects on foetal development : Species: Rat
 Application Route: oral (gavage)

Skydrol® LD4 Fire Resistant Hydraulic Fluid

Version 2.2 Revision Date: 08/09/2016 SDS Number: 150000093409 Date of last issue: 06/02/2015
Date of first issue: 10/24/2013
SDSUS / PRD / 0001

300 mg/kg
3 mg/kg

STOT - single exposure

Not classified based on available information.

Components:**Tributyl phosphate:**

Assessment: Based on available data, the classification criteria are not met.

Dibutylphenylphosphate:

Assessment: Not classified

STOT - repeated exposure

Not classified based on available information.

Components:**Tributyl phosphate:**

Assessment: Based on available data, the classification criteria are not met.

Dibutylphenylphosphate:

Exposure routes: inhalation (dust/mist/fume)

Target Organs: Respiratory system

Assessment: Not classified

Repeated dose toxicity**Product:**

Species: Rat, Male and Female

NOAEL: 40 mg/m³

Application Route: Inhalation

Exposure time: 28 days

Target Organs: Blood, Respiratory system

Remarks: Irritating to eyes and respiratory system.

Components:**Tributyl phosphate:**

Species: Mouse, Male and Female

NOEL: 75 mg/kg

Application Route: in feed

Exposure time: 90 days

Dibutylphenylphosphate:

Species: Rat, Male and Female

NOAEL: 5 mg/kg

LOAEL: 50 mg/kg

Application Route: oral (feed)

Exposure time: 90 days

Species: Rat, Male and Female

NOAEC: 5 mg/m³

Application Route: Inhalation

Skydrol® LD4 Fire Resistant Hydraulic Fluid

Version Revision Date: SDS Number: Date of last issue: 06/02/2015
2.2 08/09/2016 150000093409 Date of first issue: 10/24/2013
SDSUS / PRD / 0001

Exposure time: 90 days

Species: Rabbit, Male and Female
No observed adverse effect level: 100 mg/kg bw/day
Application Route: Dermal Study
Exposure time: 21 d

Aspiration toxicity

Not classified based on available information.

Product:

Not applicable

Components:

7-Oxabicyclo[4.1.0]heptane-3-carboxylic acid, 2-ethylhexyl ester:
Not applicable

Experience with human exposure**Product:**

Inhalation	:	Remarks: None known.
Skin contact	:	Remarks: Causes skin irritation.
Eye contact	:	Remarks: Contact with the eyes may be very painful but does not cause damage.
Ingestion	:	Remarks: None known.

SECTION 12. ECOLOGICAL INFORMATION**Ecotoxicity****Product:**

Toxicity to fish	:	LC50 (Oncorhynchus mykiss (rainbow trout)): 5.2 mg/l Exposure time: 96 h
Toxicity to daphnia and other aquatic invertebrates	:	LC50 (Daphnia magna (Water flea)): 5.8 mg/l Exposure time: 48 h
Toxicity to algae	:	EC50 (Selastrum capricornutum (green algae)): 8.2 mg/l Exposure time: 96 h

Components:**Tributyl phosphate:**

Toxicity to fish	:	LC50 (Oncorhynchus mykiss (rainbow trout)): 4.2 mg/l Exposure time: 96 h
Toxicity to daphnia and other	:	EC50 (Daphnia magna (Water flea)): 1.8 mg/l

Skydrol® LD4 Fire Resistant Hydraulic Fluid

Version 2.2 Revision Date: 08/09/2016 SDS Number: 150000093409 Date of last issue: 06/02/2015
 Date of first issue: 10/24/2013
 SDSUS / PRD / 0001

aquatic invertebrates	Exposure time: 48 h
Toxicity to algae	: EC50 (Desmodesmus subspicatus (Scenedesmus subspicatus)): 1.1 mg/l Exposure time: 72 h
Toxicity to fish (Chronic toxicity)	: NOEC (Oncorhynchus mykiss (rainbow trout)): 0.82 mg/l Exposure time: 95 d 1.7 mg/l
Toxicity to daphnia and other aquatic invertebrates (Chronic toxicity)	: NOEC (Daphnia magna (Water flea)): 1.3 mg/l Exposure time: 21 d
Dibutylphenylphosphate:	
Toxicity to fish	: LL50 (Cyprinus carpio (Carp)): 1.8 mg/l Exposure time: 96 h
Toxicity to daphnia and other aquatic invertebrates	: EC50 (Daphnia magna (Water flea)): 1.4 mg/l Exposure time: 48 h
Toxicity to algae	: EL50 (Selenastrum capricornutum (green algae)): 9.6 mg/l Exposure time: 72 h Method: EL50 method of the water accommodated fraction (W.A.F.) NOELR (Selenastrum capricornutum (green algae)): 3.5 mg/l Exposure time: 72 h Method: EL50 method of the water accommodated fraction (W.A.F.)
Toxicity to fish (Chronic toxicity)	: NOEC (Oncorhynchus mykiss (rainbow trout)): > 0.11 mg/l Exposure time: 60 d
Toxicity to daphnia and other aquatic invertebrates (Chronic toxicity)	: NOEC (Daphnia magna (Water flea)): 0.106 mg/l Exposure time: 21 d
butylated hydroxytoluene:	
Toxicity to fish	: LC50 (Fish): 0.199 mg/l Exposure time: 96 h
Toxicity to daphnia and other aquatic invertebrates	: EC50 (Daphnia (water flea)): 0.48 mg/l Exposure time: 48 h
Toxicity to algae	: EC50 (Chlorella pyrenoidosa (aglae)): 0.758 mg/l Exposure time: 96 h

Persistence and degradability**Product:**

Biochemical Oxygen Demand (BOD) : Remarks: not determined

Skydrol® LD4 Fire Resistant Hydraulic Fluid

Version 2.2 Revision Date: 08/09/2016 SDS Number: 150000093409 Date of last issue: 06/02/2015
Date of first issue: 10/24/2013
SDSUS / PRD / 0001

Chemical Oxygen Demand (COD) : Remarks: not determined

Components:**Tributyl phosphate:**

Biodegradability : Result: Readily biodegradable

Dibutylphenylphosphate:

Biodegradability : Method: Ready Biodegradability: Manometric Respirometry Test

Remarks: Readily biodegradable

Method: Ready Biodegradability: Modified MITI Test (I)

Remarks: Not readily biodegradable.

7-Oxabicyclo[4.1.0]heptane-3-carboxylic acid, 2-ethylhexyl ester:

Biodegradability : Concentration: 100 mg/l
Method: Ready Biodegradability: Modified MITI Test (I)
Remarks: Readily biodegradable

Bioaccumulative potential**Components:****Tributyl phosphate:**

Bioaccumulation : Species: Cyprinus carpio (Carp)
Bioconcentration factor (BCF): 20
Exposure time: 56 d
Method: OECD Test Guideline 305

Bioconcentration factor (BCF): 35

Exposure time: 38 d

Partition coefficient: n-octanol/water : Pow: 10,100

Dibutylphenylphosphate:

Bioaccumulation : Species: Cyprinus carpio (Carp)
Bioconcentration factor (BCF): 35
Method: OECD Test Guideline 305

Mobility in soil

No data available

Other adverse effects**Product:**

Ozone-Depletion Potential :

Regulation: 40 CFR Protection of Environment; Part 82 Protection of Stratospheric Ozone - CAA Section 602 Class I Substances

Skydrol® LD4 Fire Resistant Hydraulic Fluid

Version Revision Date: SDS Number: Date of last issue: 06/02/2015
2.2 08/09/2016 15000093409 Date of first issue: 10/24/2013
SDSUS / PRD / 0001

Remarks: This product neither contains, nor was manufactured with a Class I or Class II ODS as defined by the U.S. Clean Air Act Section 602 (40 CFR 82, Subpt. A, App.A + B).

SECTION 13. DISPOSAL CONSIDERATIONS**Disposal methods**

Waste from residues : This product meets the criteria for a synthetic used oil under the U.S. EPA Standards for the Management of Used Oil (40 CFR 279). Those standards govern recycling and disposal in lieu of 40 CFR 260 -272 of the Federal hazardous waste program in states that have adopted these used oil regulations. Consult your attorney or appropriate regulatory official to be sure these standards have been adopted in your state. Recycle or burn in accordance with the applicable standards. Dispose of in accordance with local regulations.

SECTION 14. TRANSPORT INFORMATION**International Regulation****IATA-DGR**

Not regulated as a dangerous good

IMDG-Code

Not regulated as a dangerous good

Transport in bulk according to Annex II of MARPOL 73/78 and the IBC Code

Not applicable for product as supplied.

National Regulations**49 CFR**

Not regulated as a dangerous good

SECTION 15. REGULATORY INFORMATION**EPCRA - Emergency Planning and Community Right-to-Know Act****SARA 311/312 Hazards**

: Acute Health Hazard
Chronic Health Hazard

SARA 302

: No chemicals in this material are subject to the reporting requirements of SARA Title III, Section 302.

SARA 313

: This material does not contain any chemical components with known CAS numbers that exceed the threshold (De Minimis) reporting levels established by SARA Title III, Section 313.

Clean Air Act

Skydrol® LD4 Fire Resistant Hydraulic Fluid

Version Revision Date: SDS Number: Date of last issue: 06/02/2015
2.2 08/09/2016 150000093409 Date of first issue: 10/24/2013
SDSUS / PRD / 0001

This product neither contains, nor was manufactured with a Class I or Class II ODS as defined by the U.S. Clean Air Act Section 602 (40 CFR 82, Subpt. A, App.A + B).

This product does not contain any hazardous air pollutants (HAP), as defined by the U.S. Clean Air Act Section 112 (40 CFR 61).

This product does not contain any chemicals listed under the U.S. Clean Air Act Section 112(r) for Accidental Release Prevention (40 CFR 68.130, Subpart F).

This product does not contain any chemicals listed under the U.S. Clean Air Act Section 111 SOCM/ Intermediate or Final VOC's (40 CFR 60.489).

Clean Water Act

This product does not contain any Hazardous Substances listed under the U.S. Clean Water Act, Section 311, Table 116.4A.

This product does not contain any Hazardous Chemicals listed under the U.S. Clean Water Act, Section 311, Table 117.3.

This product does not contain any toxic pollutants listed under the U.S. Clean Water Act Section 307

The components of this product are reported in the following inventories:

DSL : All components of this product are on the Canadian DSL
AICS : On the inventory, or in compliance with the inventory
ENCS : On the inventory, or in compliance with the inventory
KECI : Not listed
PICCS : Not listed
IECSC : On the inventory, or in compliance with the inventory
TSCA : On TSCA Inventory

TSCA list

No substances are subject to a Significant New Use Rule.

No substances are subject to TSCA 12(b) export notification requirements.

SECTION 16. OTHER INFORMATION**Full text of other abbreviations**

AICS - Australian Inventory of Chemical Substances; ASTM - American Society for the Testing of Materials; bw - Body weight; CERCLA - Comprehensive Environmental Response, Compensation, and Liability Act; CMR - Carcinogen, Mutagen or Reproductive Toxicant; DIN - Standard of the German Institute for Standardisation; DOT - Department of Transportation; DSL - Domestic Substances List (Canada); ECx - Concentration associated with x% response; EHS - Extremely Hazardous Substance; ELx - Loading rate associated with x% response; EmS - Emergency Schedule; ENCS - Existing and New Chemical Substances (Japan); ErCx - Concentration associated with x% growth rate response; ERG - Emergency Response Guide; GHS - Globally Harmonized System; GLP - Good Laboratory Practice; HMIS - Hazardous Materials Identification System; IARC - International Agency for Research on Cancer; IATA - International Air Transport

Skydrol® LD4 Fire Resistant Hydraulic Fluid

Version Revision Date: SDS Number: Date of last issue: 06/02/2015
 2.2 08/09/2016 150000093409 Date of first issue: 10/24/2013
 SDSUS / PRD / 0001

Association; IBC - International Code for the Construction and Equipment of Ships carrying Dangerous Chemicals in Bulk; IC50 - Half maximal inhibitory concentration; ICAO - International Civil Aviation Organization; IECSC - Inventory of Existing Chemical Substances in China; IMDG - International Maritime Dangerous Goods; IMO - International Maritime Organization; ISHL - Industrial Safety and Health Law (Japan); ISO - International Organisation for Standardization; KECI - Korea Existing Chemicals Inventory; LC50 - Lethal Concentration to 50 % of a test population; LD50 - Lethal Dose to 50% of a test population (Median Lethal Dose); MARPOL - International Convention for the Prevention of Pollution from Ships; MSHA - Mine Safety and Health Administration; n.o.s. - Not Otherwise Specified; NFPA - National Fire Protection Association; NO(A)EC - No Observed (Adverse) Effect Concentration; NO(A)EL - No Observed (Adverse) Effect Level; NOELR - No Observable Effect Loading Rate; NTP - National Toxicology Program; NZIoC - New Zealand Inventory of Chemicals; OECD - Organization for Economic Co-operation and Development; OPPTS - Office of Chemical Safety and Pollution Prevention; PBT - Persistent, Bioaccumulative and Toxic substance; PICCS - Philippines Inventory of Chemicals and Chemical Substances; (Q)SAR - (Quantitative) Structure Activity Relationship; RCRA - Resource Conservation and Recovery Act; REACH - Regulation (EC) No 1907/2006 of the European Parliament and of the Council concerning the Registration, Evaluation, Authorisation and Restriction of Chemicals; RQ - Reportable Quantity; SADT - Self-Accelerating Decomposition Temperature; SARA - Superfund Amendments and Reauthorization Act; SDS - Safety Data Sheet; TCSI - Taiwan Chemical Substance Inventory; TSCA - Toxic Substances Control Act (United States); UN - United Nations; UNRTDG - United Nations Recommendations on the Transport of Dangerous Goods; vPvB - Very Persistent and Very Bioaccumulative

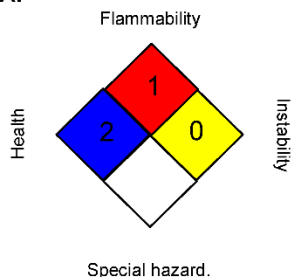
Further information**NFPA:****HMIS III:**

HEALTH	2*
FLAMMABILITY	1
PHYSICAL HAZARD	0

0 = not significant, 1 = Slight,
 2 = Moderate, 3 = High
 4 = Extreme, * = Chronic

Sources of key data used to compile the Safety Data Sheet : www.EastmanAviationSolutions.com
 Revision Date : 08/09/2016

The information provided in this Safety Data Sheet is correct to the best of our knowledge, information and belief at the date of its publication. The information given is designed only as a guidance for safe handling, use, processing, storage, transportation, disposal and release and is not to be considered a warranty or quality specification. The information relates only to the specific material designated and may not be valid for such material used in combination with any other materials or in any process, unless specified in the text.

Skydrol® LD4 Fire Resistant Hydraulic Fluid

Version	Revision Date:	SDS Number:	Date of last issue: 06/02/2015
2.2	08/09/2016	150000093409	Date of first issue: 10/24/2013

SDSUS / PRD / 0001

US / EN

