

Model: 5H31 Hydraulic Power Unit



12/2023 – Rev. 15

**For Spare Parts, Operations & Service Manuals or Service Needs
Scan the QR code or visit Tronair.com/aftermarket**



The Tronair Group of Companies: Tronair | DatcoMedia | Columbus Jack | Eagle | DAE | Malabar International

Tronair, Inc.
1 Air Cargo Pkwy East
Swanton, OH 43558

Phone: (419) 866-6301 | 800-426-6301
Web: www.tronair.com
Email: sales@tronair.com

REVISION	DATE	TEXT AFFECTED
OR	09/2004	Original Release
01	01/2005	Modified part numbers for 50 Hz applications
02	06/2006	Modified 9.7.1 Electric Panel
03	06/2008	Modified 12.2.1 Self Calibration
04	08/2008	Modified 9.2 Electric Motor, 9.16.1 Base Unit, 10.2.2 Spare Parts and Appendix VI
05	04/2009	Added 9.10.1 Electrical Components with 100 ft. Input Cord Option
06	10/2009	Modified 9.10 Electrical Components Modified 9.10.1 Electrical Components with 100 ft. Input Cord Option
07	12/2009	Modified 9.3.1 Motor Driven Hydraulic Pump Replacement Kits List
08	11/2010	Modified 9.10.1 Electrical Components with 100 ft Input Cord Option
09	05/2012	Modified 9.15.1 Voltage/Phase Monitor
10	04/2013	Modified 9.10 Electrical Components
11	07/2013	Modified 9.10 Electrical Components
12	09/2013	Modified 9.6 Hydraulic Hoses and 9.10 Electrical Components
13	12/2017	Modified 9.2 Electric Motor
14	08/2021	Added section 5.12 Infrequent HPU Use, updated 9.0 Maintenance, modified Parts List
15	12/2023	Updated sections 9.7.3.a System Pressure Relief Valve, 9.12 External Components and 11.4.1 Self Calibration

TABLE OF CONTENTS

PAGE

1.0	PRODUCT INFORMATION	1
1.1	DESCRIPTION.....	1
1.2	MODEL & SERIAL NUMBER.....	1
1.3	MANUFACTURER	1
1.4	FUNCTION.....	1
1.5	REQUIREMENTS	1
2.0	SAFETY INFORMATION	1
2.1	USAGE AND SAFETY INFORMATION	1
2.2	EXPLANATION OF WARNING & DANGER SIGNS	1
2.3	COMPONENT SAFETY FEATURES.....	1
2.4	FUNCTIONAL SAFETY FEATURES	2
2.5	PERSONAL PROTECTION EQUIPMENT	2
2.6	SAFETY GUIDELINES	2
2.7	GENERAL COMMENT	2
3.0	PREPARATION PRIOR TO FIRST USE	2
3.1	GENERAL.....	2
3.2	SERVICING RESERVOIR	2
3.3	CONNECTING ELECTRICAL LEADS	2
4.0	TRAINING	2
4.1	TRAINING REQUIREMENTS	2
4.2	TRAINING PROGRAM	2
4.3	OPERATOR TRAINING.....	2
5.0	OPERATION	3
5.1	OPERATING PARAMETERS	3
5.2	NUMERICAL VALUES	3
5.2.1	Fluid	3
5.2.2	Physical.....	3
5.2.3	Motor Driven Hydraulic Pump	4
5.2.4	Electric Motor	4
5.2.5	Filters	4
5.2.6	Hand Pump (<i>Option M</i>)	4
5.3	LOCATION & LAYOUT OF CONTROLS	5
5.3.1	Front Panel Controls	5
5.3.2	Electrical Control Panel.....	6
5.3.3	Hydraulic Control Panel	7
5.3.4	Rear Panel Controls.....	8
5.3.5	Hydraulic Pump Controls	9
5.3.6	Hand Pump Controls (<i>Option M</i>).....	10
5.4	START UP PROCEDURES	11
5.4.1	Procedure for First Time or Different Electrical Supply ONLY	11
5.4.2	Initial Start Up of the HPU	11
5.5	PRELIMINARY ADJUSTMENTS FOR OPERATION	11
5.5.1	Flow Control Adjustment	11
5.5.2	Pressure Control Adjustment	12
5.5.3	Reservoir Selector Valve Operation	12
5.5.4	Bypass Valve Operation.....	12
5.6	BLEEDING AIR FROM SYSTEM.....	12
5.6.1	To Easily Purge the Unit of Air	13
5.7	SPLIT SYSTEM OPERATION	13
5.8	HAND PUMP OPERATION (<i>Option M</i>).....	13
5.8.1	To Operate the Hand Pump	13
5.9	SAMPLE VALVE	13
5.10	EMERGENCY SHUT DOWN PROCEDURE	13
5.11	DESCRIPTION OF ALARM SYSTEMS	13
5.11.1	High Fluid Temperature Indicator (<i>Option S</i>)	14
5.11.2	Voltage/Phase Monitor Indicator (<i>Options G – J</i>).....	14
5.11.3	High and Low Reservoir Level Indicator (<i>Option L</i>).....	14
5.11.4	Clogged Filter Indicator Light (<i>Standard</i>)	14
5.12	INFREQUENT HPU USE	14
5.12.1	Infrequent HPU Use Start Up Procedure	14
6.0	PACKAGING AND STORAGE	15
6.1	PACKAGING REQUIREMENTS	15
6.2	HANDLING	15
6.3	PACKAGING PROTECTION	15

6.4	LABELING OF PACKAGING	15
6.5	STORAGE COMPATIBILITY	15
6.6	STORAGE ENVIRONMENT	15
6.7	STORAGE SPACE AND HANDLING FACILITIES	15
7.0	TRANSPORTATION.....	15
8.0	TROUBLESHOOTING.....	16
8.1	HPU WILL NOT START	16
8.2	NO FLOW	16
8.3	REDUCED FLOW	17
8.4	NO PRESSURE or REDUCED PRESSURE	17
8.5	FLUID OVERHEATS.....	17
8.6	HAND PUMP (<i>Option M</i>) IS NOT PUMPING FLUID.....	17
9.0	MAINTENANCE.....	18
9.1	GENERAL.....	18
9.2	ELECTRIC MOTOR	18
9.3	MOTOR DRIVEN HYDRAULIC PUMP	19
9.3.1	Motor Driven Hydraulic Pump Replacement Kits List.....	19
9.4	HYDRAULIC FLUID	19
9.5	FILTERS	20
9.5.1	Pressure Filter.....	21
9.5.2	Return Filter	22
9.5.3	Hand Pump (<i>Option M</i>) Filter	23
9.5.4	Desiccant Air Filter	24
9.6	HYDRAULIC HOSES.....	25
9.7	INSTRUMENT PANEL.....	26
9.7.1	Electric Panel	27
9.7.2	Hydraulic Panel.....	28
9.7.3	Control Block/Flowmeter	29
9.7.3.a	System Pressure Relief Valve.....	30
9.7.3.b	Check Valve.....	31
9.7.3.c	Bypass Valve	31
9.8	RESERVOIR ASSEMBLY.....	32
9.9	RETURN MANIFOLD ASSEMBLY	34
9.9.1	Return System Pressure Relief Valve	35
9.10	ELECTRICAL COMPONENTS	37
9.10.1	Electrical Components With 100 ft Input Cord Option	39
9.11	HEAT EXCHANGER ASSEMBLY.....	42
9.12	EXTERNAL COMPONENTS.....	43
9.13	SPLIT SYSTEM ASSEMBLY	44
9.14	ELECTRIC FILTER CLOGGING INDICATOR	45
9.15	ADDITIONAL FEATURES	46
9.15.1	Voltage/Phase Monitor (<i>Options G – J</i>).....	46
9.15.2	Electric Reservoir Level (<i>Option L</i>).....	47
9.15.3	Hand Pump (<i>Option M</i>)	49
9.15.3.a	Two Stage Pump with Relief	51
9.15.4	Calibration Port (<i>Option Q</i>).....	53
9.15.5	Electric Over-Temperature (<i>Option S</i>).....	54
9.16	REPLACEMENT LABELS PARTS LISTS.....	55
9.16.1	Base Unit	55
9.16.2	Fluid	55
9.16.3	Filter Element Kit.....	55
9.16.4	Split System	55
9.16.5	Pyrometer	56
9.16.6	Hand Pump (<i>Option M</i>)	56
9.16.7	Calibration Port (<i>Option Q</i>).....	56
10.0	PROVISION OF SPARES.....	56
10.1	SOURCE OF SPARE PARTS.....	56
10.2	RECOMMENDED SPARE PARTS LISTS	56
10.2.1	Spare Electrical Parts.....	56
10.2.2	Spare Parts	56
11.0	CALIBRATION OF INSTRUMENTATION	57
11.1	SOURCE OF CALIBRATION	57
11.2	ANALOG PRESSURE GAUGE – System Pressure	57
11.2.1	Self Calibration.....	57
11.3	ANALOG PRESSURE GAUGE (Hand Pump Pressure- <i>Option M Only</i>)	58
11.3.1	Self Calibration.....	58
11.4	ANALOG TEMPERATURE GAUGE (Pyrometer)	58
11.4.1	Self Calibration.....	58

12.0 IN SERVICE SUPPORT 58
13.0 GUARANTEES/LIMITATION OF LIABILITY 59
14.0 APPENDICES 59

This product can not be modified without the written approval of Tronair, Inc. Any modifications done without written approval voids all warranties and releases Tronair, Inc., its suppliers, distributors, employees, or financial institutions from any liability from consequences that may occur. Only Tronair OEM replacement parts shall be used.

1.0 PRODUCT INFORMATION

1.1 DESCRIPTION

Hydraulic Power Unit

1.2 MODEL & SERIAL NUMBER

Reference nameplate on unit.

1.3 MANUFACTURER

TRONAIR, Inc.
1 Air Cargo Pkwy East
Swanton, Ohio 43558 USA

Telephone: (419) 866-6301 or 800-426-6301
Fax: (419) 867-0634
E-mail: sales@tronair.com
Website: www.tronair.com

1.4 FUNCTION

The Hydraulic Power Unit (HPU) provides a source of clean, pressurized hydraulic fluid for performing required aircraft maintenance. An electric motor drives a pressure compensated piston pump. Filters are provided on the pressure and return systems. A bypass (dump) valve allows starting and stopping of the unit under a no-load, safe condition. The unit may use either the aircraft or on-board HPU reservoir. Cooling is provided for continuous operation.

1.5 REQUIREMENTS

Adequate electrical power must be provided for proper functioning of the HPU. See the unit nameplate for proper voltage and frequency. See the Technical Manual for proper sizing of electrical supply and protection equipment in the facility.

2.0 SAFETY INFORMATION

2.1 USAGE AND SAFETY INFORMATION

The HPU provides pressurized hydraulic fluid for performing aircraft maintenance.

To insure safe operations please read the following statements and understand their meaning. Also refer to your equipment manufacturer's manual for other important safety information. This manual contains safety precautions which are explained below. Please read carefully.



WARNING! — Warning is used to indicate the presence of a hazard that **can cause severe personal injury, death, or substantial property damage** if the warning notice is ignored.

CAUTION! — Caution is used to indicate the presence of a hazard that **will or can cause minor personal injury or property damage** if the caution notice is ignored.

2.2 EXPLANATION OF WARNING & DANGER SIGNS



Accidental Starts! Before servicing the HPU or equipment, always disconnect electrical power supply to prevent accidental starting.



Rotating Parts! Keep hands, feet, hair, and clothing away from all moving parts to prevent injury. Never operate the HPU with covers, shrouds, or guards removed.



Electrical Shock! Never touch electrical wires or components while the HPU is attached to the power source. They can be sources of electrical shock. **DO NOT** operate HPU with cabinet panels removed.



Pressurized Fluid! Before servicing the HPU or equipment, always open the bypass valve to relieve any residual pressure in the hydraulic system.

2.3 COMPONENT SAFETY FEATURES

- Pump/Motor coupling guard
- Sheet metal panels
- Pressure and return system relief valves
- Control circuit fuses
- Motor overload protection

2.4 FUNCTIONAL SAFETY FEATURES

- Emergency shut off switch
- Floor lock
- Calibration port shut off valve
- Fluid sample shut off valve

2.5 PERSONAL PROTECTION EQUIPMENT

- Safety glasses must be worn when operating the HPU.
- Additional equipment recommended by the fluid manufacturer (gloves, etc.). **Reference Appendix of Safety Data Sheet pertaining to fluid(s).**

2.6 SAFETY GUIDELINES

- Operator must be properly trained prior to operating the HPU.
- HPU power switch must be in "Off" position when connecting or disconnecting hoses to the aircraft.
- Bypass valve must be in the "Open" position when starting or stopping the HPU.
- Electrical power must be disconnected from the HPU and the bypass valve must be in the "Open" position before servicing the HPU. (Reference Technical Manual for details on servicing the HPU.)

2.7 GENERAL COMMENT

The HPU is intended to be operated by personnel trained in the proper use in conjunction with the aircraft maintenance manual.

The HPU must be used in accordance with the Technical and Operator Manuals and the intended aircraft.

3.0 PREPARATION PRIOR TO FIRST USE

3.1 GENERAL

Prior to operating the HPU, the user should become familiar with this Operator Manual.

3.2 SERVICING RESERVOIR

Fill the reservoir with the correct fluid (see label next to reservoir fill for correct type of fluid) until fluid level is above the minimum fluid level mark but below the maximum fluid level. See 5.3.1 *Front Panel Controls* for reservoir fill location.

3.3 CONNECTING ELECTRICAL LEADS



Electrical Shock! Never touch electrical wires or components while electrical power is attached. Only qualified electricians should connect the electrical leads.

Install plug onto the electrical cord. If motor rotation is not correct, change any two of the three leads at the plug. **Reference 11.0 Electrical Power and Protection Requirements** for power requirements and fuse sizes. (See 5.4 *Start up Procedures* before starting HPU.)



WARNING!

Balanced three phase voltage must be available to prevent overheating and damage to the motor.

Voltage unbalanced between phases occurs when the voltages differ from one another.

Some reasons for imbalance are:

1. **Unequal loading of each phase**
2. **Poor connections in the supply**
3. **Single phase condition caused by blown fuses or bad connections**

If these conditions occur in the incoming power system, a protective device, such as a voltage monitor, should be installed on the machine to prevent motor damage.

4.0 TRAINING

4.1 TRAINING REQUIREMENTS

The employer of the operator is responsible for providing a training program sufficient for the safe operation of the HPU.

4.2 TRAINING PROGRAM

The employer provided operator training program should cover safety procedures concerning use of the HPU in and around the intended aircraft at the intended aircraft servicing location.

4.3 OPERATOR TRAINING

The operator training should provide the required training for safe operation of the HPU.

NOTE: Maintenance and Troubleshooting are to be performed by a skilled and trained technician.

5.2.3 Motor Driven Hydraulic Pump

A pressure compensated, adjustable maximum volume piston pump.

- Maximum flow at 60 Hz 11 gpm (41.6 lpm)
- Maximum flow at 50 Hz 9 gpm (34.6 lpm)
- Maximum operating pressure at 50 Hz and 60 Hz 3,500 psi (241 bar)
- System pressure relief valve setting 3,550 psi (258 bar)
- Performance Curve for 50 Hz and 60 Hz Reference **Figure 5.2.3**

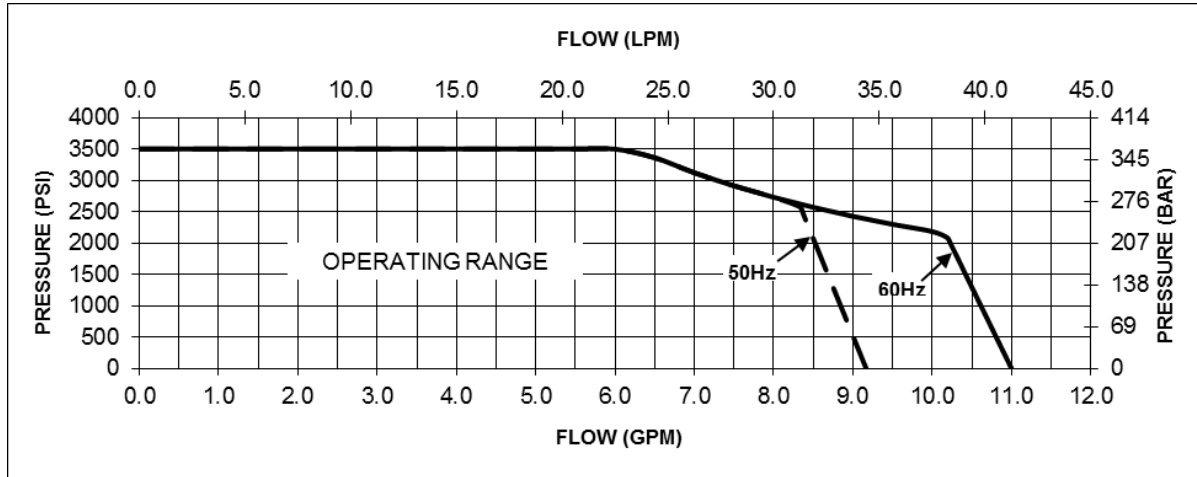

Performance Curve (50 Hz and 60 Hz)

5.2.4 Electric Motor

A 15 horsepower, TEFC electric motor is the prime mover for the HPU. This is attached to the hydraulic pump using a pump/motor adapter and a spider/coupling rotating interface.

MOTOR POWER REQUIREMENTS

60 Hz Applications		50 Hz Applications	
Voltage	Full Load Amps	Voltage	Full Load Amps
208	44.2	200	48.0
230	40.0	220	41.0
380	24.2	380	23.7
460	20.0	415	23.0
575	16.0	440	22.0

5.2.5 Filters

- Pressure 2 micron rating, non-bypass high collapse microglass type. Non-cleanable element
- Return 5 micron rating, 25 psi (1.72 bar) bypass microglass type. Non-cleanable element
- Hand Pump (Option M) 2 micron rating, non-bypass microglass type. Non-cleanable element
- Air/Desiccant 3 micron filter, silica gel desiccant type. Non-cleanable element

5.2.6 Hand Pump (Option M)

Two stage hand pump, low pressure stage 0–500 psi (0–34.47 bars) and 500–5,000 psi (34.47–344.74 bars) high pressure stage. Pump automatically changes stage internally based on system pressure.

- Low Pressure Stage Piston Diameter 1½ in (38.1 mm)
- Working Pressure 0–500 psi (0–34.47 bar)
- Displacement/Stroke 2.1 in3 (34.4 cm3)
- Force/100 psi (6.89 bar) 12.0 lbs/100 psi (7.74 N/bar)
- High Pressure Stage Piston Diameter 5/8 in (15.88 mm)
- Working Pressure 500–5000 psi (34.47–344.74)
- Displacement/Stroke 0.4 in3 (6.55 cm3)
- Force/100 psi (6.89 bar) 2.2 lbs/100 psi (1.42 N/bar)
- Pressure Relief Setting 5,250 psi (362.0 bar)

5.3 LOCATION & LAYOUT OF CONTROLS

5.3.1 Front Panel Controls

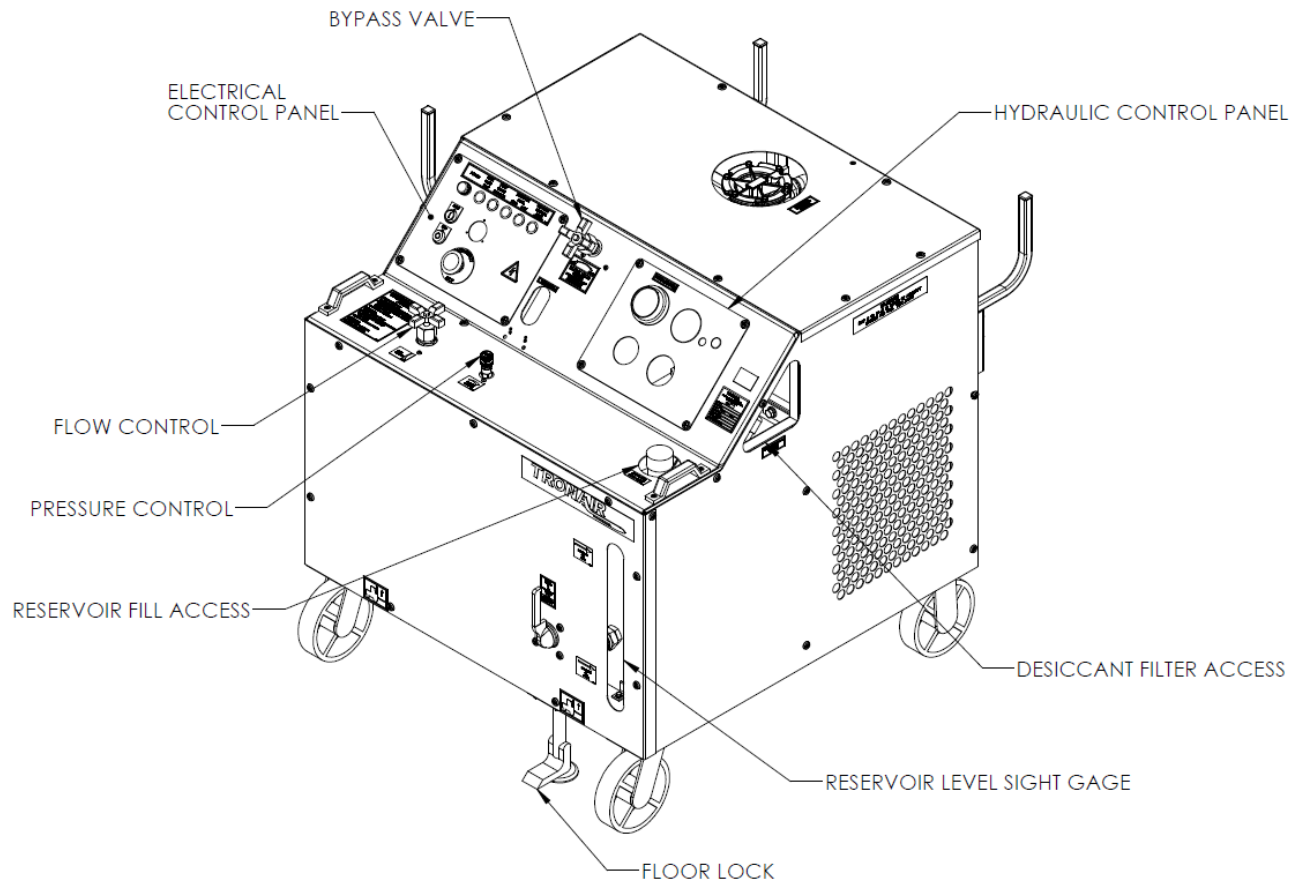

Electrical Control Panel	See Section 5.3.2
Hydraulic Control Panel	See Section 5.3.3
Bypass Valve	For loading and unloading the motor driven hydraulic pump
Flowmeter	Displays the flow from the motor driven hydraulic pump
Pump Control Access	See Figure 5.3.5 - Hydraulic Pump Controls
Reservoir Selector	For selecting between using the aircraft reservoir or the HPU reservoir
Sight Gauge	Visual indicator displays the fluid level in the reservoir
Reservoir Fill Access	Locking cap for servicing the HPU reservoir
Desiccant Filter	Access to the reservoir air filter/desiccant filter
Hand Pump (<i>Option M</i>)	Access for hand pump and relief screw, handle stored inside
Floor Lock	Locking/unlocking, foot actuated and released floor lock

5.3.2 Electrical Control Panel

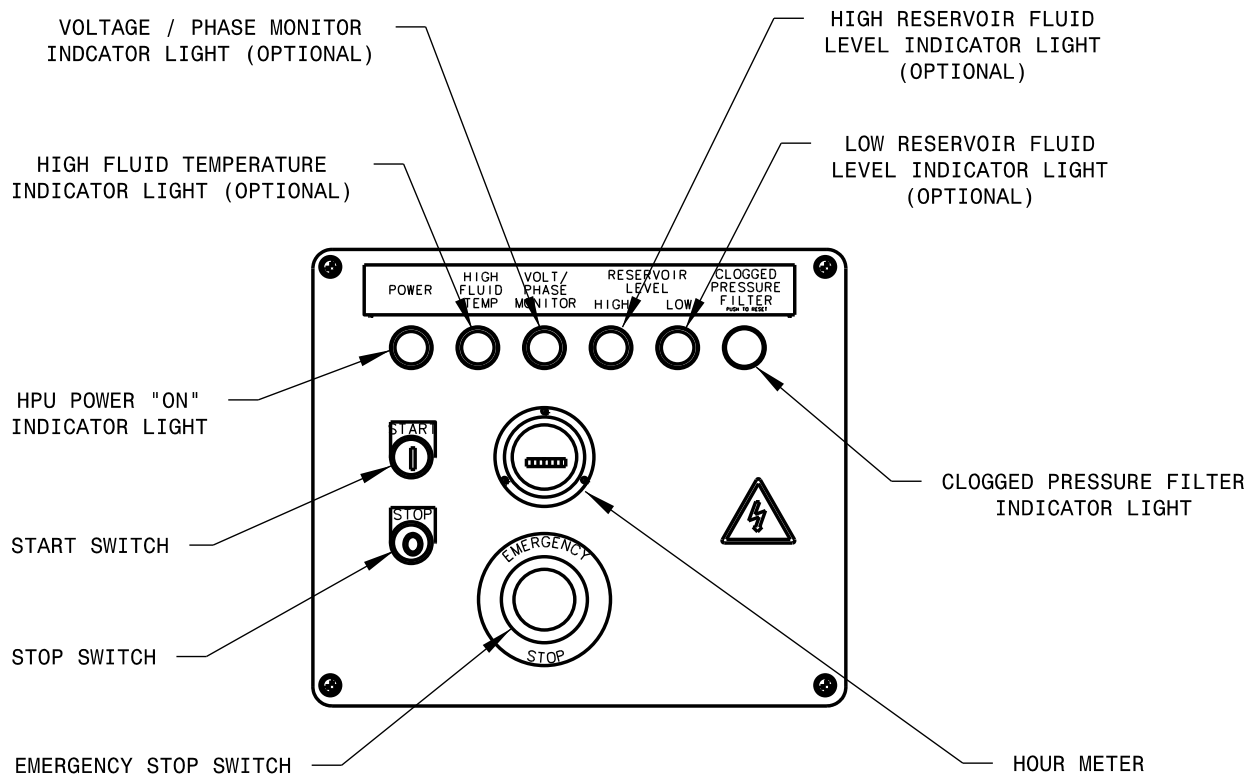

Emergency Stop	Removes power to all electrical devices, must turn to reset
Stop Switch	Turns off the electric motors driving the hydraulic pump and cooling fan
Start Switch	Turns on the electric motors driving the hydraulic pump and cooling fan
HPU Power "On" Indicator Light	Light is illuminated when the electric motors driving the hydraulic pump and cooling fan are on
High Fluid Temperature Indicator Light (<i>Option S</i>)	Light is illuminated when the return fluid temperature reaches 170° F (77° C) or above. The HPU will shut down when light is illuminated. The HPU can be re-started when the fluid has cooled and the indicator light is off
High Reservoir Fluid Level Indicator Light (<i>Option L</i>)	Light is illuminated when the fluid level in the reservoir is above the normal operating range. The HPU will shut down until the fluid level is restored to a normal operating level
Low Reservoir Fluid Level Indicator Light (<i>Option L</i>)	Light is illuminated when the fluid level in the reservoir is below the normal operating range. The HPU will shut down until the fluid level is restored to a normal operating level
Voltage/Phase Monitor Indicator Light (<i>Options G – J</i>)	Light is illuminated if any of the following conditions occur <ul style="list-style-type: none"> - Voltage imbalance between L1, L2, L3, greater than 5% - Loss of voltage from L1, L2, L3 - Over voltage from L1, L2, L3, greater than 5% - Change in phase orientation between L1, L2, L3. The HPU will shut down until the electrical problem is corrected
Clogged Pressure Filter Indicator Light	Light is illuminated when the pressure filter element requires changing. The HPU will not shut down when illuminated. Pressing the illuminated button will reset the light

5.3.3 Hydraulic Control Panel

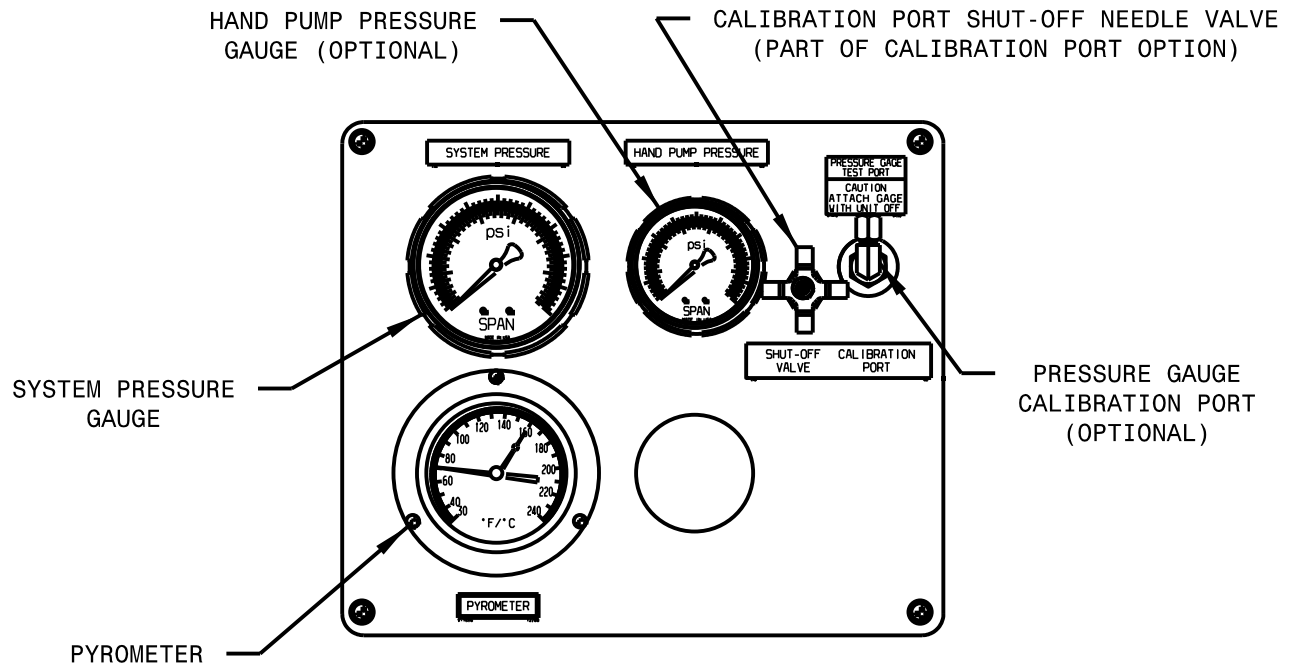

System Pressure Gauge	Displays the system pressure on an analog fluid dampened gauge
Pyrometer	Displays the fluid temperature in the return system on an analog gauge. A warning indicator preset to 160° F (71° C) warns of high operating temperature
Pressure Gauge Calibration Port (Option Q)	Allows for calibration of the system pressure gauge up to the operating pressure of HPU. Calibration port shut off valve must be used in conjunction with the calibration port
Calibration Port Shut Off Valve (Part of Calibration Port Option Q)	Used to shut off pressure to the calibration port. This valve should only be opened when the external standard gage is attached. (See Operation & Service Manual for proper procedure)
Hand Pump Pressure Gauge (Option M)	Displays the hand pump system pressure on an analog fluid dampened gauge

5.3.4 Rear Panel Controls

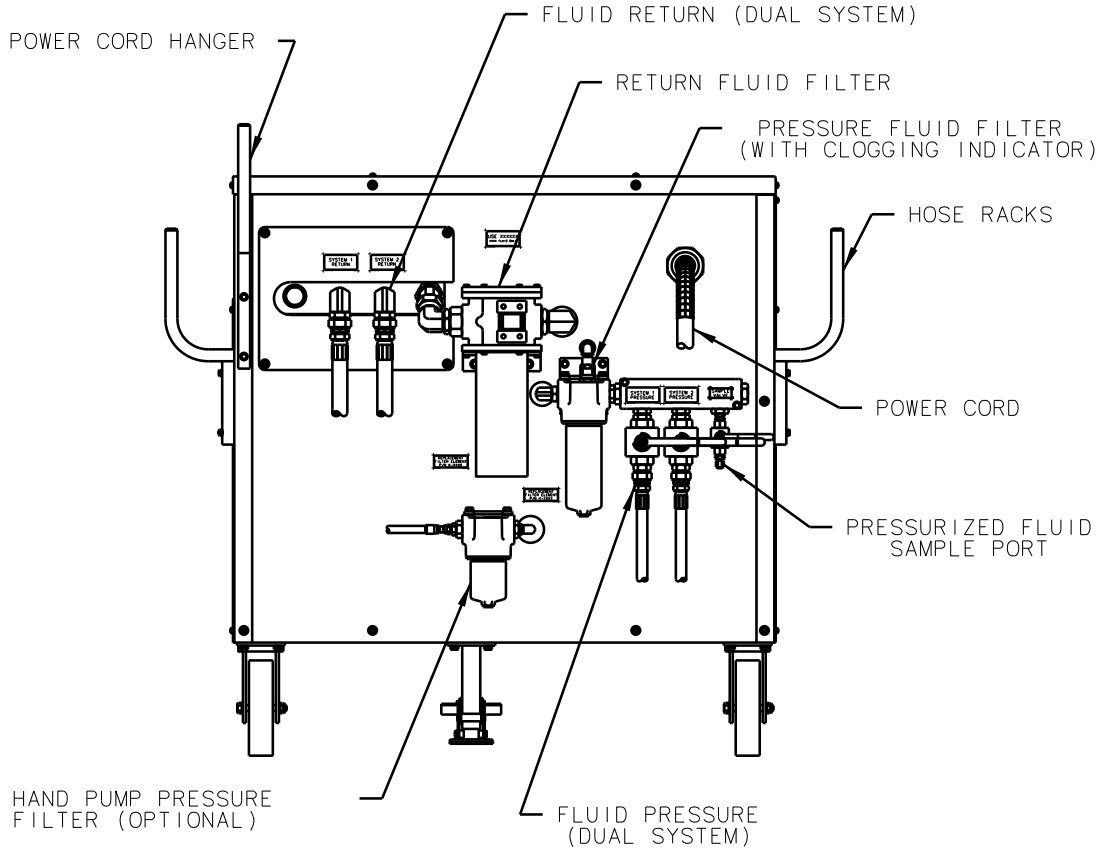

* Fluid Pressure System	The source of pressurized fluid from the HPU that flows to the aircraft pressure system through the pressure hose
* Fluid Return System	Fluid returning to the HPU from the aircraft that flows through the return hoses
Pressure Fluid Filter	Filters the pressurized fluid before it flows to the aircraft pressure system
Return Fluid Filter	Filters the fluid returning from the aircraft before it enters the HPU
Pressurized Fluid Sample Port	A sample valve is provided to obtain a fluid sample for analysis. In order to obtain a representative sample
Hand Pump Pressure Filter (Option M)	Filters the pressurized fluid before it flows to the aircraft system
Hose Racks	Location for storing the pressure, return and optional hand pump hoses when not in use
Power Cord Hanger	Location for storing the power cord when not in use

* **Split System consists of two (2) each of these items.**

5.3.5 Hydraulic Pump Controls

The hydraulic pump flow control and pressure control are located through the pump control access door.

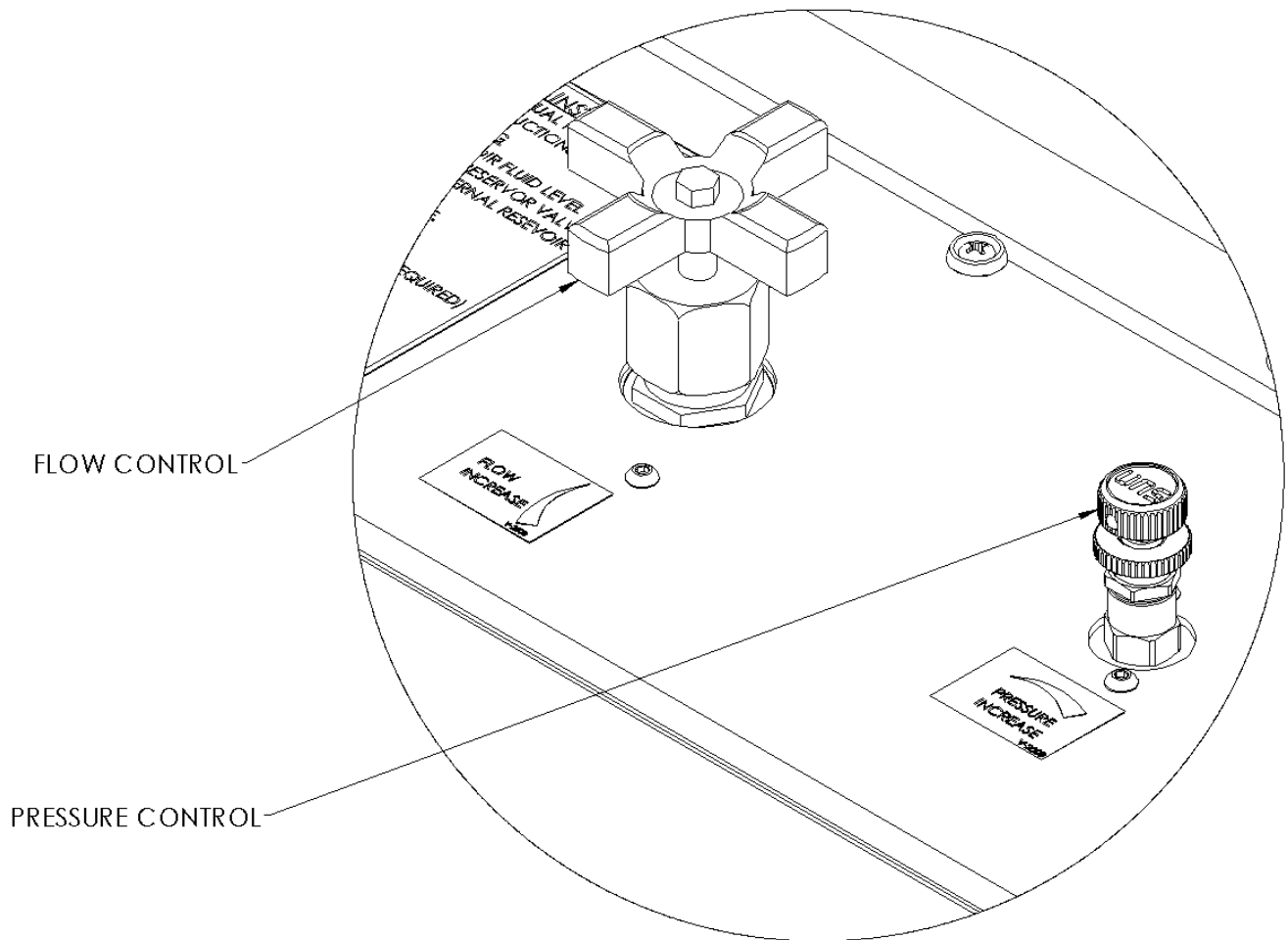

Flow Control	This control is used to set the maximum flow required from the HPU
Pressure Control	The pressure control is used to set the system pressure of the HPU during operation

5.3.6 Hand Pump Controls (*Option M*)
Reference 5.9 Hand Pump Operation

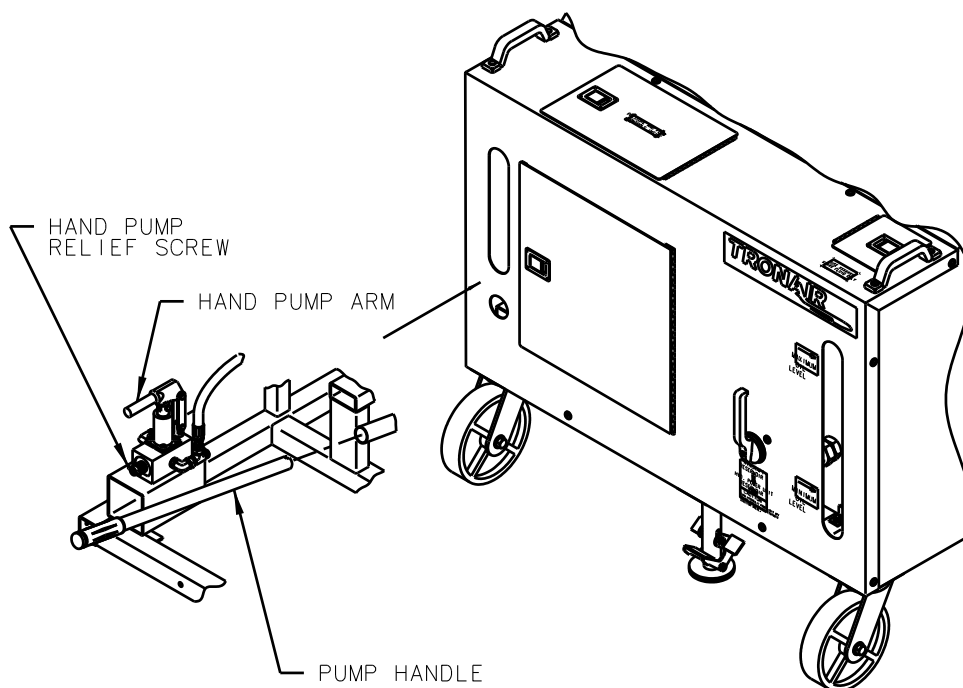

Pump Handle	Located inside the front access door is the hand pump handle used for opening and closing the hand pump relief screw and stroking the hand pump arm
Hand Pump Relief Screw	Accessed through the front panel opening, this screw allows opening and closing of the hand pump hydraulic circuit using the hand pump handle
Hand Pump Arm	The handle is used to access the hand pump arm used for up and down motion to produce hydraulic flow and pressure

5.4 START UP PROCEDURES

5.4.1 Procedure for First Time or Different Electrical Supply ONLY

Phase Monitor (Options G – J Only): Check that the phase monitor light on the instrument panel is not illuminated. If the light is illuminated, change any two of the three input leads at the plug. Once the phase monitor light is not illuminated with power attached, check for proper motor rotation.

- a. Remove the pump/motor coupling guard.



Rotating Parts! Keep hands, feet, hair, and clothing away from all moving parts to prevent injury. Never operate the HPU with covers, shrouds, or guards removed.

- b. Verify that the unit has been prepared for use by connecting electrical leads and servicing the reservoir. (Reference section 3.0 Preparation Prior to First Use.)
- c. Keeping hands clear of the pump/motor coupling area, momentarily press the start button and immediately press the stop button.
- d. Observe direction of rotation of the pump/motor coupling. When the Operator is facing the front panel, the pump/motor coupling should be rotating in a clockwise direction.

PUMP/MOTOR COUPLING GUARD

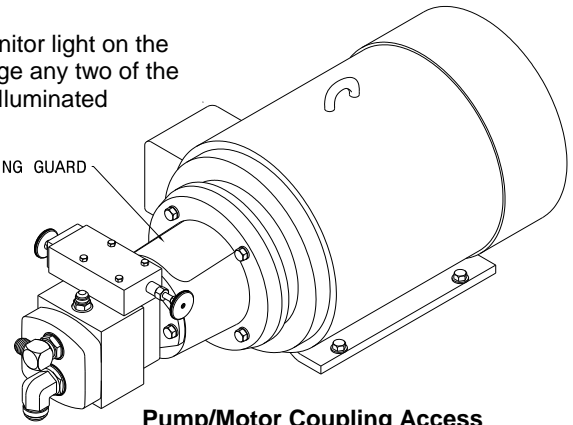

Pump/Motor Coupling Access



Electrical Shock! Never touch electrical wires or components while the HPU is attached to the power source. They can be sources of electrical shock.

Do not operate HPU with cabinet panels removed.

- e. If the pump/motor coupling is rotating in a counter-clockwise direction, change any two of the three leads at the plug. Observe direction of rotation to verify that pump/motor is rotating in a clockwise direction.
- f. Replace the pump/motor coupling guard.

5.4.2 Initial Start Up of the HPU

- a. Unit must be prepared per section 3.0 Preparation Prior to First Use and section 5.4.1 First Time or Different Electrical Supply ONLY before starting the HPU.
- b. Operator must be familiar with this manual and be properly trained prior to starting the HPU.
- c. Connect quick disconnects to hose ends or cap the pressure and return hose ends.
- d. Place the reservoir selector valve in "HPU Reservoir" position.
- e. Place the bypass valve in the "Open" position.
- f. Press the start switch and adjust the flow control until 6 gpm (22.71 lpm) is displayed on the flowmeter. (If no flow displays on the flowmeter after adjusting the flow control, reference *Troubleshooting 8.2 No Flow*).
- g. Close the bypass valve, adjust the pressure control until 3,000 psi (206.84 bars) is displayed on the pressure gauge. (If no pressure displays on the system pressure gauge after adjusting the pressure control, reference *Troubleshooting 8.4 No Pressure or Reduced Pressure*).
- h. Open the bypass valve; press the stop switch.

NOTE: Maintenance and Troubleshooting are to be performed by a skilled and trained technician.

5.5 PRELIMINARY ADJUSTMENTS FOR OPERATION

The following are basic to the operation of the HPU and should be thoroughly understood. The pressure and flow controls have lock nuts to prevent rotation of the control shaft during operation. These nuts should be moved away from the pump during adjustment of flow or pressure in order to eliminate binding of the control shafts.

5.5.1 Flow Control Adjustment

- a. Open bypass valve.
- b. Select "Hydraulic Power Unit" position with reservoir selector valve.
- c. Start HPU.
- d. Adjust flow control on pump for maximum desired flow. Observing the flowmeter, read flow in gallons (liters) per minute directly from flowmeter. Be sure the control shaft lock nut is loose during adjustment. Tighten after adjustment to maintain setting.

5.5.2 Pressure Control Adjustment

- a. Open bypass valve.
- b. Select "Hydraulic Power Unit" position with reservoir selector valve.
- c. Start HPU.
- d. Close bypass valve.
- e. Adjust pressure control for desired pressure; observing the system pressure gauge, read in psi (bars). Be sure the control shaft lock nut is loose during adjustment. Tighten after adjustment to maintain setting.

NOTE: Once the flow and pressure controls have been adjusted, it is not necessary to change these settings after each operation unless desired.

5.5.3 Reservoir Selector Valve Operation

Operation of the reservoir selector valve allows the operator to select either the aircraft reservoir (closed loop) or the HPU reservoir (open loop).

CAUTION!



The reservoir selector valve should only be operated when the HPU is not running. The operation of the reservoir selector valve should be done prior to starting the HPU.

a. Aircraft Reservoir Position (Closed Loop)

In this position, the HPU is dependent on the aircraft reservoir and system for an adequate supply of fluid. Cavitation, due to an inadequate fluid supply from the aircraft, may be indicated by erratic fluctuation of the system pressure gauge or flowmeter. At times, the aircraft fluid supply will be restricted due to small return oil lines in the aircraft. If this is a problem, decrease the flow control setting until the cavitation is eliminated.

b. HPU Reservoir Position (Open Loop)

In this position, the HPU reservoir supplies fluid to the pump and accepts return fluid from the aircraft. It is desirable to operate the HPU in this mode since it eliminates any possibility of cavitation. Since the HPU reservoir is vented to atmosphere and the aircraft is at a higher level, it is normal for the aircraft reservoir to drain into the HPU reservoir. It is, therefore, necessary to be sure that sufficient room is available in the HPU reservoir to accommodate the additional fluid.

CAUTION!



The aircraft system reservoir must be serviced after completion of operational testing.

In the "HPU Reservoir" position, faster landing gear swings are usually possible since there is no restriction to flow at the pump inlet.

5.5.4 Bypass Valve Operation

The bypass valve is used for unloading the pump. The valve should be either in the fully open or fully closed position only. Do not operate the valve in a partially open position.

a. Start Up Operation

The bypass valve must be opened prior to starting the HPU in order to allow the motor to start under a no load condition and not pressurize the aircraft hydraulic system.

b. Shut Down Operation

Prior to shutdown, the bypass valve must be opened to bleed off any residual system pressure.

CAUTION!



Excessive heat, which could damage machine components, will be generated if the bypass valve is partially open or is used for regulating flow or pressure.

- Use the flow and pressure controls for regulation.
- Use the bypass valve for unloading the system only.

5.6 BLEEDING AIR FROM SYSTEM

Rapid fluctuations of the pressure gage and flow-meter are indications of cavitation or entrapped air in the hydraulic lines and/or components. Air may enter the system when:

- Operating the unit with insufficient oil in the reservoir.
- Changing a component on the aircraft.
- Changing hose connections and/or couplings.

- 5.6.1 To Easily Purge the Unit of Air
- Fill reservoir to recommended level.
 - Open bypass valve.
 - Place reservoir selector valve in "Hydraulic Power Unit" position.
 - Start unit and adjust flow control to maximum position.

NOTE: If fluid is not flowing, shut off HPU and reference section 8.2 No Flow in Troubleshooting section of Technical Manual

- Run unit for five (5) minutes and shut off.
- If additional bleeding is required, connect the pressure and return hoses together and open all pressure and return ball valves at the rear of the HPU. Start the HPU and slowly close the bypass valve (**system pressure should remain under 200 psi (approximately 14 bar)**). Allow fluid to flow at full flow for five (5) minutes, then shut the HPU off.



WARNING!

Failure to open the return ball valves will cause hose or valve rupture. Property damage and personal injury can result.

5.7 SPLIT SYSTEM OPERATION

The split system option allows control of fluid flow to aircraft with two hydraulic systems. The systems consist of two sets of hoses and valves located in the pressure system. The valves are mounted on the rear of the hydraulic power unit and are of the 90o ball type. The valves are open when the operating handle is in line with the valve.

Although both systems may be operated simultaneously, usually only one system is required at any one time. If both valve sets are open simultaneously, the pump output will be divided between the two systems. Also, cross flow between aircraft reservoirs may occur if a reservoir level or pressure differential exists. Select valve positions prior to starting machine.

5.8 HAND PUMP OPERATION (*Option M*)

The Hand Pump Option allows for filling the reservoir (low pressure) or static testing of components or system (high pressure). The hand pump circuit is separate from the main hydraulic system; a separate filter and hose are attached to the back panel of the HPU.

5.8.1 To Operate the Hand Pump

- Remove the pump handle from inside the front access door. (Reference **Figure 5.3.6 – Hand Pump Controls**)
- Insert the end of the pump handle through the front panel opening into the hand pump relief screw.
- Turn the pump handle clockwise to close the relief screw.
- Insert the pump handle onto the hand pump arm through the front panel slot.
- Pump the handle using an up and down motion. Observe the hand pump system pressure on the hydraulic control panel (**Figure 5.3.3 Hydraulic Control Panel**). The pump is an automatic two stage pump. 500 psi (34.47 bar) can be produced with high fluid flow and 5,000 psi (344.74 bar) can be produced with low fluid flow.
- Turning the relief screw in a counter-clockwise direction releases hydraulic pressure in the hand pump system.



Pressurized Fluid! Before disconnecting the hand pump pressure hose, ALWAYS open the relief screw valve to relieve any residual pressure in the hydraulic system.

5.9 SAMPLE VALVE

A sample valve is provided on the rear of the unit to obtain a fluid sample for analysis or inspection.



Pressurized Fluid! Before servicing the HPU or equipment, ALWAYS open the bypass valve to relieve any residual pressure in the hydraulic system.

5.10 EMERGENCY SHUT DOWN PROCEDURE

In the event an emergency shutdown is necessary, press the emergency stop switch located on the electrical panel. (Reference **Figure 5.3.2 – Electrical Control Panel**) Open the bypass valve to remove any system pressure.

5.11 DESCRIPTION OF ALARM SYSTEMS

Reference **Figure 5.3.2 – Electrical Control Panel**.

5.11.1 High Fluid Temperature Indicator (*Option S*)

The indicator light for high fluid temperature is an active light which will illuminate when the return fluid temperature is 170° F (77° C) or above. The HPU will shut down if the light is illuminated. The HPU can be re-started when the fluid has cooled sufficiently and the light has shut off.

If the high temperature light is illuminated reference section **8.0 Trouble Shooting**.

5.11.2 Voltage/Phase Monitor Indicator (*Options G – J*)

The indicator light for the voltage/phase monitor is an active light which will illuminate if there is a problem with the incoming electrical power source. The HPU will shut down if the light is illuminated.

If the voltage/phase monitor light is illuminated, reference section **8.0 Trouble Shooting**.

5.11.3 High and Low Reservoir Level Indicator (*Option L*)

The indicator lights for high and low reservoir level are active lights which will illuminate when the reservoir fluid level is either above the maximum level or below the minimum level. The HPU will shut down if either of the lights are illuminated.

If the light on either of the reservoir level indicator lights, restore the fluid level in the reservoir to a normal operating range.

5.11.4 Clogged Filter Indicator Light (*Standard*)

The indicator light for the clogged filter is a passive light which will illuminate if the pressure filter element becomes clogged or is in need of replacement. The HPU will not shut down if the light is illuminated.

If the clogged filter indicator light is illuminated, the pressure filter element requires changing. Reference section **9.14 Electric Filter Clogging Indicator** (*Option R*) for maintenance procedure. Pressing the clogging filter indicator light will reset the light and the light will turn off.

NOTE: Maintenance and Troubleshooting are to be performed by a skilled and trained technician.

5.12 INFREQUENT HPU USE

If the unit is not used frequently Tronair recommends operating the unit monthly. Operating regularly assures that the seals are kept lubricated, eliminates air pockets in the system, reduces moisture in the fluid and helps extend the hose life.

5.12.1 Infrequent HPU Use Start Up Procedure

1. Assure that the HPU reservoir is filled between the minimum and maximum level
2. Connect the unit to a proper electrical power source
3. If unit is equipped with a run around kit, connect the pressure and return hoses together
4. Place the reservoir selector valve in "HPU Reservoir" position
5. Open the return ball valves on the back of the unit
6. Pressure ball valves
 - a. If unit **IS** equipped with a runaround kit **ensure the hoses are connected to each other**, open the pressure ball valves on the back of the unit
 - b. If the hoses **are not connected to each other**, close the pressure ball valves on the back of the unit
7. Verify the return ball valves on the back of the unit are open
8. Fully open the bypass valve
9. Adjust the pressure control to the minimum setting (CCW)
10. Start the unit and verify the flow is above "0" on the flowmeter
 - a. If flow is present: adjust the flow control to increase flow (CW)
 - b. If no flow is immediately present: turn unit off, verify the motor rotation (see 3.3 Connecting Electrical Leads), correct rotation if necessary
11. Set flow to ½ the maximum flow capacity of the unit. You may need to increase the pressure adjustment to achieve flow.
12. Bypass valve
 - a. If unit **IS** equipped with a runaround kit **ensure the hoses are connected to each other**, fully close the bypass valve
 - b. If the hoses **are not connected to each other**, leave the bypass valve fully open
13. Operate the unit for 15-30 minutes in this condition. Fluid temperature should reach 100°-130° F (37.8°-54.4° C)
14. At the completion of the 15-30 minute circulation run, open the bypass valve and shut off the unit
15. Remove the electric power
16. Place the selector valve in the Aircraft Reservoir position
17. Close the pressure and return ball valves on the back of the unit

6.0 PACKAGING AND STORAGE

6.1 PACKAGING REQUIREMENTS

- a. Drain hydraulic fluid until level is below the minimum fluid level indicator.
- b. Block up the unit on a pallet so the wheels are not touching the pallet or shipping container.
- c. Plug all hose ends.
- d. Strap unit to pallet or shipping container using the tie down rings located on the frame bottom.

NOTE: Use at least four (4) straps with a minimum 2,000 lb (907.2 kg) capacity each.

6.2 HANDLING

The unit is designed to be moved by hand using the handles located on the front of the unit. The unit can be lifted by means of a fork truck from the center of the machine. Lifting must be from the motor side of the unit only.

NOTE: Be sure the forks are long enough to reach the frame cross members for stability during lifting. Spread the forks to their maximum width for stability. Reference 7.0 – HPU on Forklift.

6.3 PACKAGING PROTECTION

No special packaging material for cushioning or suspension is required.

6.4 LABELING OF PACKAGING

Packaging should be labeled as follows:

**DO NOT DROP
THIS SIDE UP
DO NOT STACK** ↑

6.5 STORAGE COMPATIBILITY

No special considerations for short term storage (less than three months).

6.6 STORAGE ENVIRONMENT

Cover HPU with a suitable, non-abrasive tarp if storing outside. For storage periods greater than three months, drain hydraulic fluid from all hoses and the reservoir. Cover unit to protect outside surface.

If storing outside, protect unit from freezing water, sand, dirt, and direct sunlight. A cover is highly recommended.

6.7 STORAGE SPACE AND HANDLING FACILITIES

Weight (Dry):..... 1,200 lbs (544 kg)
 Width..... 53 in (134.6 cm) Add 7.5 in (19 cm) for Split System
 Height..... 53 in (134.6 cm)
 Depth..... 74 7/8 in (191.0 cm)

7.0 TRANSPORTATION

1. Do not stack Hydraulic Power Units.
2. The unit can be lifted by means of a fork truck from the motor side center of the HPU.

NOTE: Be sure the forks are long enough to reach frame cross members for stability during lifting. Spread the forks to their maximum width for stability.

Weight: 1,200 lbs (544 kg)

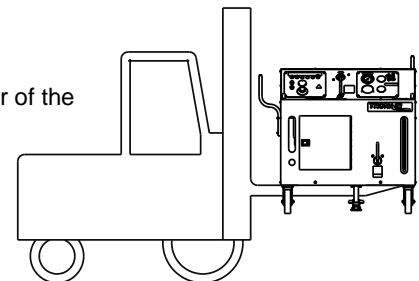

HPU on Forklift

8.0 TROUBLESHOOTING

The following is a guide to solutions of common problems associated with the HPU. See related Appendix for Hydraulic and Electrical Schematics.

If the problem is not resolved using the Troubleshooting information, call the manufacturer for Technical Assistance (See Section **1.3 Manufacturer**).

NOTE: Maintenance and Troubleshooting are to be performed by a skilled and trained Technician.

8.1 HPU WILL NOT START

Possible Cause	Solution
Supply power off	Check incoming power and restore power. Check across-the-line voltage on all three phase legs
Supply power fuses are blown/ circuit breakers tripped	Check and replace. Check across-the-line voltage on all three phase legs
Control Transformer fuses blown	Check and replace
Supply power phase or voltage incorrect (Phase/Voltage Monitor Option G – J only)	Voltage/Phase Monitor Indicator light will be illuminated Refer to Section 3.3 Connecting Electrical Leads
Reservoir fluid level is too high or too low (Electric Reservoir Level Option L only)	One reservoir level indicator light (Low or High) will be illuminated. Fill the reservoir above the Minimum Fluid Level arrow to extinguish the Low Level light. Drain fluid below the Maximum Fluid Level arrow to extinguish the High Level light
High return fluid temperature (Electric Over-Temperature Option S only)	High Fluid Temperature indicator light will be illuminated. Allow the hydraulic fluid to cool until the light goes out. Refer to Section 8.5 for over-heated causes
Motor has tripped thermal overload device	Allow the motor to cool. The thermal overload device (motor starter) will reset automatically after sufficient cooling. The tripped condition is usually caused by loading the motor beyond its rated capacity; however, any condition (such as unbalanced voltage) that causes an increase in amperage can result in a tripped condition

NOTE: Using the bypass valve to meter flow or pressure will increase the motor load and may cause the thermal overload device to trip. Refer to section 5.5.4 Bypass Valve Operation for proper use of the bypass valve.

8.2 NO FLOW

Possible Cause	Solution
Motor turning in wrong direction	See Section 3.3 Connecting Electrical Leads
Flow control set too low	Increase flow setting
Fluid level in reservoir too low	Service the HPU reservoir
Air in pump inlet lines	Disconnect the HPU from the aircraft. Fill the HPU reservoir to a level above the pump inlet port. Set the reservoir selector valve to the HPU Reservoir position. Fully open the Bypass Valve. Close the Pressure and Return ball valves at the rear of the unit. Adjust the pump flow to maximum and "bump" the start and stop switches to "jog" the motor. Flow should be indicated at the Flowmeter on first or second "jog"

NOTE: Under some conditions where a large amount of air has entered the system, the pump may not be able to draw an initial prime. If this occurs, loosen the inlet hose near the pump and allow air to escape. Re-tighten the hose when fluid appears.

Possible Cause	Solution
Motor is turning but pump is not	Check pump and motor couplings to ensure they are tight
Flow path does not exist	A flow path (such as a moving actuator or an open circuit) must exist for flow to be present. When system pressure exceeds the compensator control setting, or when the system no longer requires flow, the control de-strokes the pump while maintaining the preset pressure

8.3 REDUCED FLOW

Possible Cause	Solution
Flow control set too low	Increase flow setting
Pressure adjustment is set too low	Slightly increase pressure setting
Pressure compensator control is reducing pump output	When system pressure exceeds the compensator control setting, or when the system no longer requires flow, the control de-strokes the pump while maintaining the preset pressure
Pump inlet is not receiving enough fluid (cavitation)	Follow the procedure for "Air in pump inlet lines" in Section 8.2
Motor is "Single Phasing"	Motor is not getting power on all three phase legs. Check across-the-line voltage on all three phase legs
Supply voltage is 50 Hz	Pumps used on 50 Hz units will flow at only 83% of the pump nameplate rating. An HPU designed to run on 50 Hz will supply flow as stated in the specifications for that unit

8.4 NO PRESSURE or REDUCED PRESSURE

Possible Cause	Solution
Pressure adjustment is set too low	Increase pressure adjustment
Motor is "Single Phasing"	Motor is not getting power on all three phase legs. Check across-the-line voltage on all three phase legs
Pump inlet is not receiving enough fluid (cavitation)	Follow the procedure for "Air in pump inlet lines" in Section 8.2
Flow path is open	Pressure is resistance to flow. The HPU will reach full pressure as flow paths (such as moving actuators and open valves) are closed

8.5 FLUID OVERHEATS

Possible Cause	Solution
Fan is not functioning properly	Check the cooler fan output. Forced air should be easily detected at the right hand side of the HPU. Check the fuses for the fan motor (See Appendices – Electrical Schematic INS-1608 and INS-2016)
Bypass valve or rear ball valve is being used in a partially closed position	The bypass valve and all ball valves must be used in a fully open or fully closed position. These valves are not intended for metering flow. All flow adjustments must be made using the pump flow control

8.6 HAND PUMP (Option M) IS NOT PUMPING FLUID

Possible Cause	Solution
Release screw is open	Use the slotted end of the pump handle to close the release screw located at the base of the pump
Ball valve is closed	Open the ball valve for the pump inlet line located at the bottom of the reservoir
Pump piston is filled with air	If the pump is not primed after several strokes, remove the bleed screw from the top of the pump piston (See Section 9.13.9.a – Pump Diagram). Slowly stroke the pump until fluid is present at the bleed screw. Replace the bleed screw

9.0 MAINTENANCE

If the unit is not used frequently Tronair recommends operating the unit monthly. Operating regularly assures that the seals are kept lubricated, eliminates air pockets in the system, reduces moisture in the fluid and helps extend the hose life. If the unit is not used frequently see 5.12 Infrequent Use Procedure.

9.1 GENERAL

Periodically inspect the HPU for loose fasteners, hose fittings, damaged hoses, and worn electrical cables. Make repairs as needed for safe operation.

Reference Sections **9.2 – 9.16** for Parts Lists, Descriptions and Illustrations.

9.2 ELECTRIC MOTOR

The Electric Motor is pre-greased by the manufacturer. Periodic greasing is necessary on a frequently used HPU. Reference **Appendix – Lincoln Motor Manual** for details.

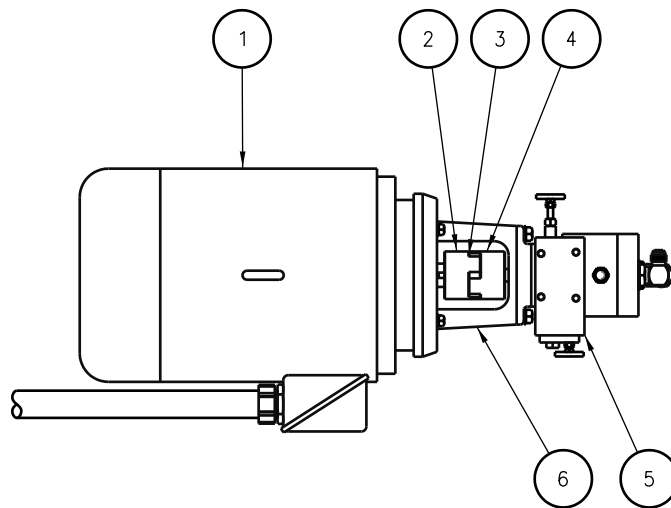

PARTS LIST

Item	Part Number	Description	Qty
1	Reference table below	ELECTRIC MOTOR	1
2	H-2424-15	COUPLING (MOTOR HALF)	1
3	H-2427	SPIDER (HYTREL)	1
4	H-2424-04	COUPLING (PUMP HALF)	1
5	K-4263	KIT, HYDRAULIC PUMP	1
6	HC-1775-06	PUMP/MOTOR ADAPTER	1

60 Hz Applications	
Voltage	Part Number
208	EC-1186-11
230	EC-1186-11
380	EC-1186-11
460	EC-1186-11
575	EC-1186-12

50 Hz Applications	
Voltage	Part Number
200	EC-1555-11
220	EC-1555-11
380	EC-1555-11
415	EC-1555-11
440	EC-1555-11

9.3 MOTOR DRIVEN HYDRAULIC PUMP

The hydraulic pump does not require regular maintenance. Under normal operating conditions, the pump will perform for thousands of hours of use without rebuilding. See **Appendix – Oil Gear Pump Manual** for further details.

9.3.1 Motor Driven Hydraulic Pump Replacement Kits List

Fluid Type: Aviation Phosphate Ester, Type IV

Part Number	Description
K-2405	Kit, Shaft Seal and Retainer
K-1997	Kit, Gaskets and O-rings
K-3655	Kit, Shaft and Bearing Assembly

9.4 HYDRAULIC FLUID

Any time an unusual color, smell or visual indicator is noticed with the hydraulic fluid, a sample analysis should be performed to determine the condition of the fluid. (See Section **5.9 – Sample Valve Operation**)

Refer to the manufacturer of the specific fluid for your unit to obtain additional information:

Model Number..... 5H31

Fluid Type Aviation Phosphate Ester, Type IV

9.5 FILTERS

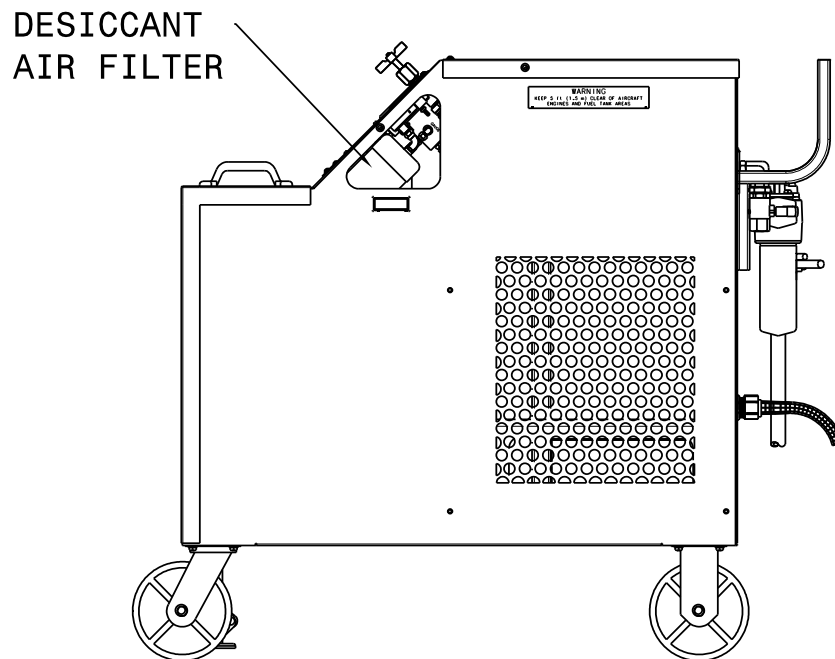
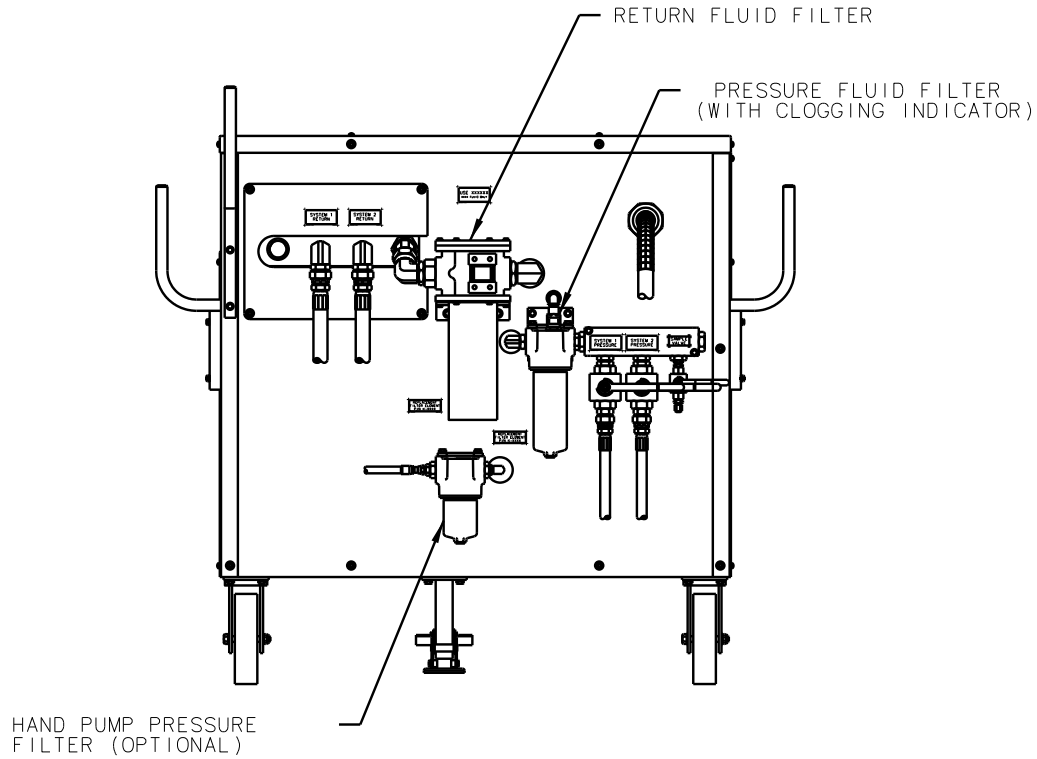

9.5.1 Pressure Filter

Replace the filter element any time the clogged filter indicator light (*Option R*) is triggered or when the pop-up indicator located on the filter head changes to red during operation.

Replace the filter element annually to ensure proper cleanliness of the hydraulic system. This is a minimum requirement.

Standard filter changes depend on how frequently the HPU is used and the cleanliness of the fluid, along with the environment to which the HPU is exposed. Periodic fluid analysis is recommended to properly determine the optimum frequency of filter element changes.

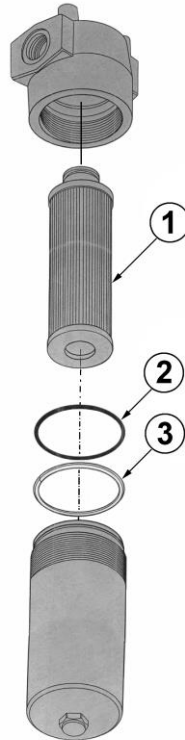

Parts List

Fluid Type: Aviation Phosphate Ester, Type IV

Item	Part Number	Description	Qty
2 & 3	K-3797	KIT, SEAL	1
1, 2, 3	K-3428	KIT, REPLACEMENT FILTER ELEMENT	1

9.5.2 Return Filter

Replace the return filter element at the same time the pressure filter element is being replaced.

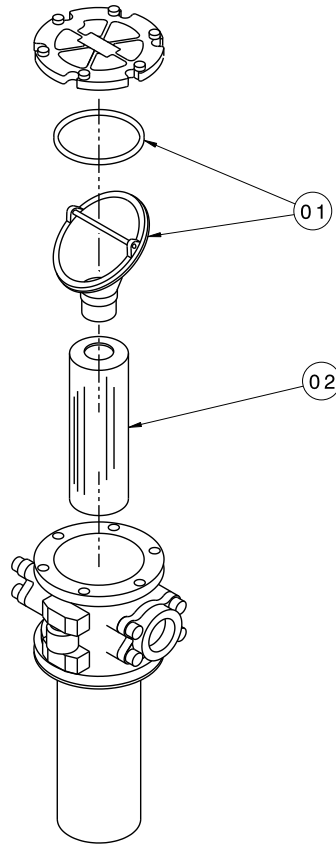

Parts List

Fluid Type: Aviation Phosphate Ester, Type IV

Item	Part Number	Description	Qty
1	HC-2006-350	O-RING (BOWL)	2
1, 2	K-3494	KIT, REPLACEMENT FILTER ELEMENT	1

9.5.3 Hand Pump (Option M) Filter

Replacement of the hand pump filter element is dictated by frequency of use and the cleanliness of the fluid, along with the environment to which the HPU is exposed. Changing the hand pump filter element at the same time as the pressure filter element will ensure a regular maintenance schedule.

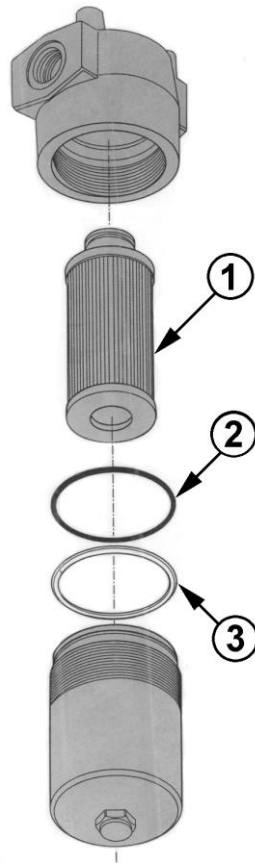

Parts List

Fluid Type: Aviation Phosphate Ester, Type IV

Item	Part Number	Description	Qty
1	HC-2006-144	O-RING (BOWL)	1
2	*	BACKUP RING (BOWL)	1
1, 2, 3	K-3752	KIT, REPLACEMENT FILTER ELEMENT	1

* Part number not released at time of publish. Call Tronair for Part number.

9.5.4 Desiccant Air Filter

Replace the desiccant/air filter whenever the material inside the element is pink or reddish in color (see Element Label for details).

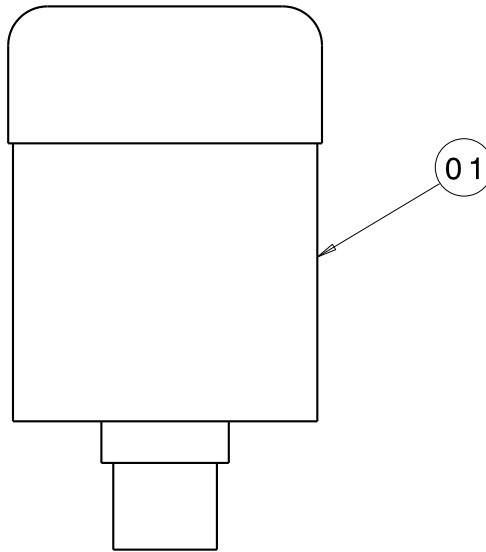

Parts List

Fluid Type: Aviation Phosphate Ester, Type IV

Item	Part Number	Description	Qty
1	HC-1763	FILTER ELEMENT	1

9.6 HYDRAULIC HOSES

Hoses used on the HPU must be periodically inspected for damage, blisters, leaks, or hose end problems. Any damaged or defective hose should be replaced as soon as possible.

Hoses used on Aviation Phosphate Ester, Type IV units have a shorter useful life than hoses used on Mineral Base units. Surface moisture is normal with Aviation Phosphate Ester, Type IV hoses as long as the fluid does not form into drops.

Hose Location		
Item	From	To
1	SELECTOR VALVE	PUMP INLET
2	PUMP OUTLET	FLOWMETER
3	CONTROL MANIFOLD	PRESSURE FILTER
4	CONTROL MANIFOLD	PRESSURE GAUGE
5	CASE DRAIN	COOLER (REAR)
6	COOLER (FRONT)	RETURN MANIFOLD
7	CONTROL MANIFOLD	RETURN MANIFOLD
8	SELECTOR VALVE (TOP)	RETURN FILTER
9	RETURN PRESSURE RELIEF	TANK

Parts List

Fluid Type: Aviation Phosphate Ester, Type IV

Item	Part Number	Description	Qty
1	TF-1040-39*12.8	ASSEMBLY, HOSE	1
2	TF-1041-09*35.0	ASSEMBLY, HOSE	1
3	TF-1041-14*32.8	ASSEMBLY, HOSE	1
4	TF-1040-42*23.0	ASSEMBLY, HOSE	1
5	TF-1041-55*38.3	ASSEMBLY, HOSE	1
6	TF-1040-45*16.3	ASSEMBLY, HOSE	1
7	TF-1041-15*31.3	ASSEMBLY, HOSE	1
8	TF-1040-39*35.3	ASSEMBLY, HOSE	1
9	TF-1134-02*17.5	ASSEMBLY, HOSE	1
10	TF-1041-15*600	ASSEMBLY, HOSE EXTERNAL RETURN	1
11	TF-1041-15*300	ASSEMBLY, HOSE EXTERNAL RETURN	1
12	TF-1041-09*600	ASSEMBLY, HOSE EXTERNAL PRESSURE	1
13	TF-1041-09*300	ASSEMBLY, HOSE EXTERNAL PRESSURE	1

9.7 INSTRUMENT PANEL

Refer to Section **9.6 Hydraulic Hoses** concerning hose inspection for general maintenance on Item 3 Hose Assembly.

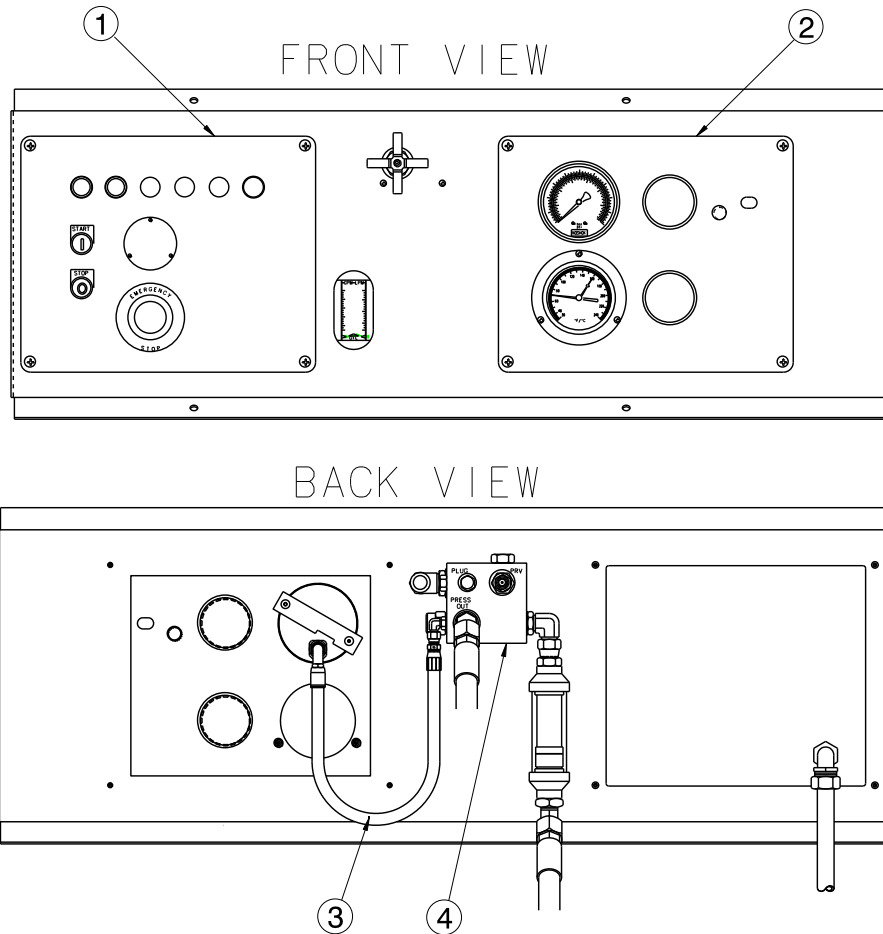

Parts List

Fluid Type: Aviation Phosphate Ester, Type IV

Item	Part Number	Description	Qty
1	See Section 9.7.1	ELECTRIC PANEL	1
2	See Section 9.7.2	HYDRAULIC PANEL	1
3	TF-1041-14*32.8	ASSEMBLY, HOSE #4	1
4	See Section 9.7.3	CONTROL BLOCK/FLOWMETER	1

9.7.1 Electric Panel

The Electric Panel does not require regular general maintenance.

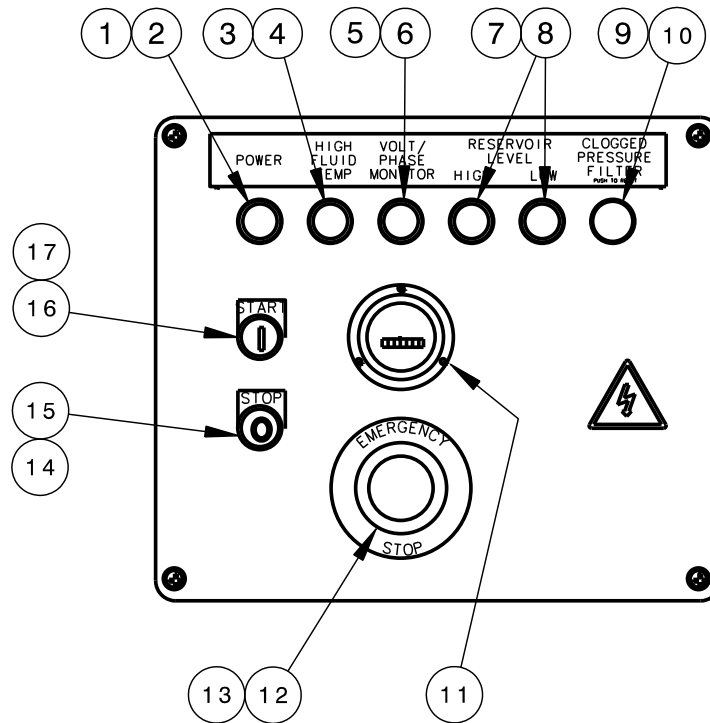

Parts List

Fluid Type: Aviation Phosphate Ester, Type IV

Item	Component	Part Number	Description	Qty
1	Standard	EC-1945-01	LIGHT, DIFFUSED PILOT	1
2	Standard	EC-1951-MN5G	POWER, MODULE W/LATCH	1
3	Option	EC-1945-03	LIGHT, DIFFUSED PILOT	1
4	Option	EC-1951-MN5Y	POWER, MODULE W/LATCH	1
5	Option	EC-1945-03	LIGHT, DIFFUSED PILOT	1
6	Option	EC-1951-MN5Y	POWER, MODULE W/LATCH	1
7	Option	EC-1945-04	LIGHT, DIFFUSED PILOT	2
8	Option	EC-1951-MN5B	POWER, MODULE W/LATCH	2
9	Option	EC-1952	PUSH BUTTON, ILLUMINATED/FLUSH	1
10	Option	EC-1944	POWER, MODULE W/CONTACT/LATCH	1
11	Option	EC-1577	HOUR METER (50 HZ OPERATION)	1
		EC-1578	HOUR METER (60 HZ OPERATION)	1
12	Option	EC-1948	SWITCH, EMERGENCY STOP	1
13	Standard	EC-1946-MX02	CONTACT BLOCK W/LATCH	1
14	Standard	EC-1953-ME205	PUSH BUTTON, NON-ILLUMINATED	1
15	Standard	EC-1946-MX01	CONTACT BLOCK W/LATCH	1
16	Standard	EC-1953-MF306	PUSH BUTTON, NON-ILLUMINATED	1
17	Standard	EC-1946-MX10	CONTACT BLOCK W/LATCH1	1
N/S	Standard	H-1203	TAPE, SILICONE SPONGE	54

9.7.2 Hydraulic Panel

Annual calibration of instrumentation is recommended. See Section 12.0 – Calibration of Instrumentation for details of calibration.

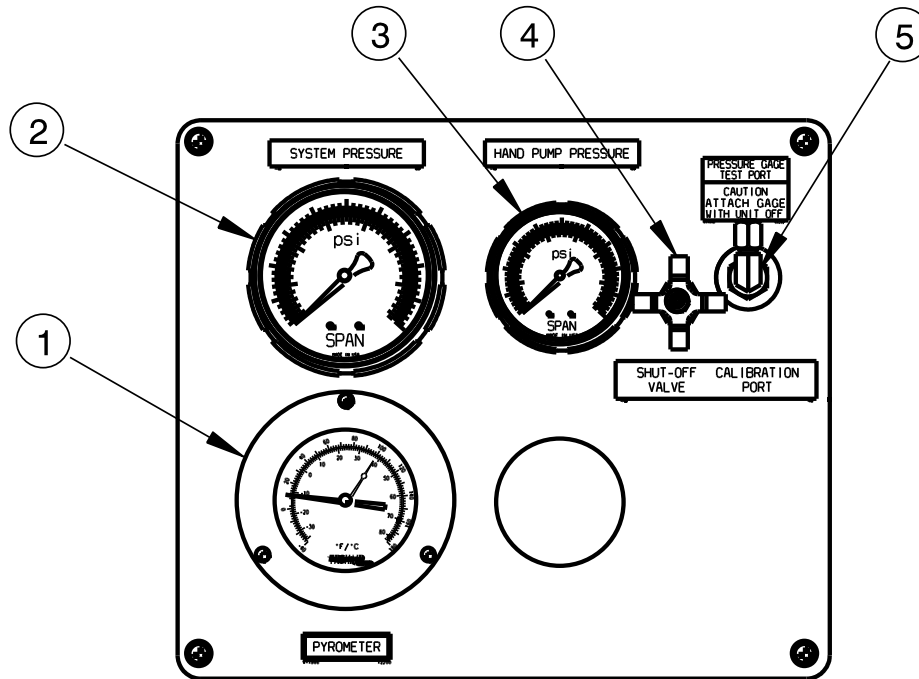

Parts List

Fluid Type: Aviation Phosphate Ester, Type IV

Item	Part Number	Description	Qty
1	HC-1769-02	PYROMETER	1
2	HC-2144	SYSTEM PRESSURE GAUGE	1
3	HC-2146	PRESSURE GAUGE (Hand Pump Option Only)	1
4	HC-1900-02	SHUT OFF NEEDLE VALVE (Calibration Port Option Only)	1
5	See Section 9.13.10	CALIBRATION PORT (Optional)	1
N/S	H-1203	TAPE, SILICONE SPONGE	54

9.7.3 Control Block/Flowmeter

The Control Block components do not require regular general maintenance.

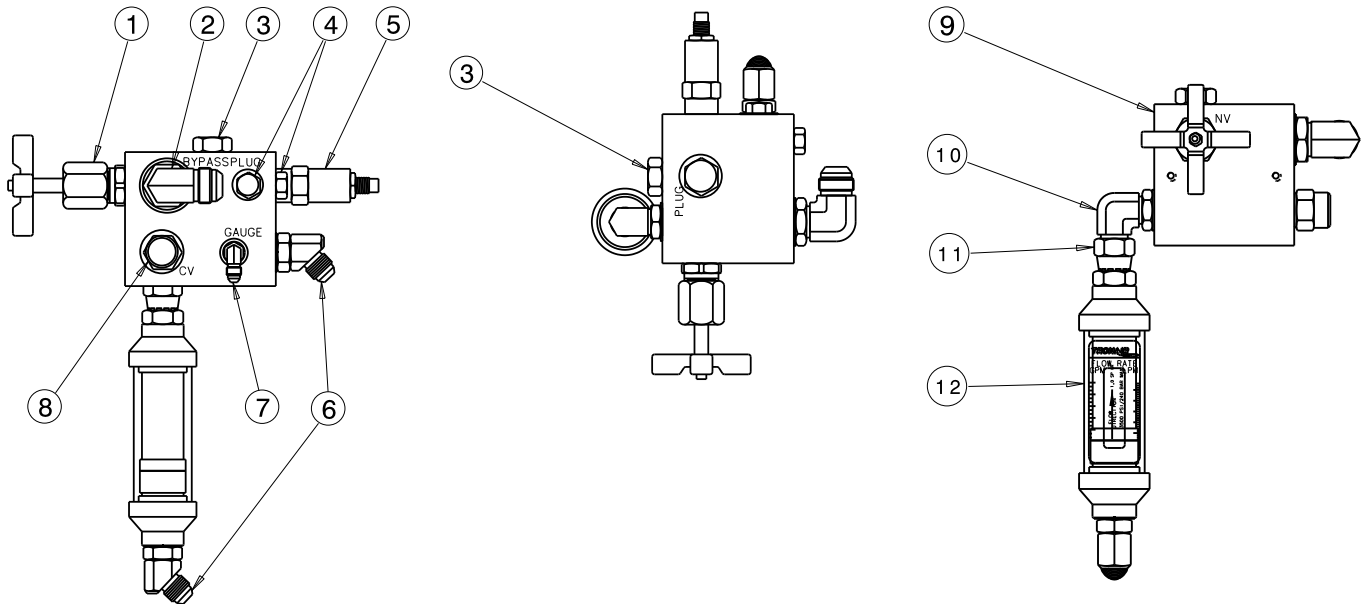

Parts List

Fluid Type: Aviation Phosphate Ester, Type IV

Item	Part Number	Description	Qty
1	HC-1927-05	NEEDLE VALVE	1
2	N-2001-18-S-E	ELBOW, STRAIGHT THREAD (#12)	1
3	N-2066-10-S-E	O-RING HEX PLUG (#10)	2
4	N-2066-06-S-E	PLUG, O-RING HEX (#6)	2
5	HC-2149	PRESSURE RELIEF VALVE	1
6	N-2042-07-S-E	ELBOW, 45 STRAIGHT THREAD (#8-10)	2
7	N-2001-03-S-E	ELBOW, STRAIGHT THREAD (#4)	1
8	HC-1677	CHECK VALVE	1
9	J-3399	PRESSURE MANIFOLD	1
10	N-2001-15-S-E	ELBOW, STRAIGHT THREAD ((#10)	1
11	N-2036-07-S-E	SWIVEL, 37° FEMALE (#10)	1
12	HC-2132	FLOWMETER, 15 GPM/3,500 PSI	1
	HC-2132-A1	FLOWMETER (Calibrated)	1

9.7.3.a System Pressure Relief Valve

The System Pressure Relief Valve does not require regular general maintenance. It is possible however, for a contaminant to hold the relief valve in a partially open condition. If service is required, the new or repaired relief valve must be reset to 3,750 psig.

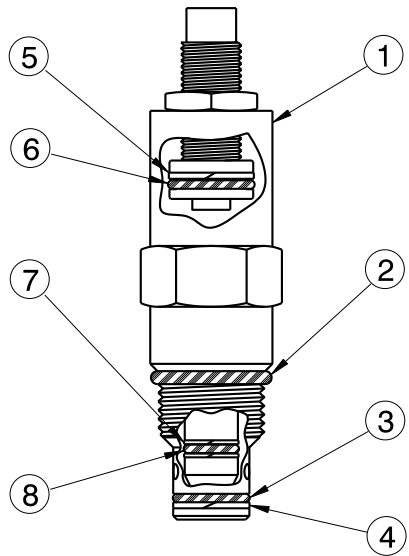

Parts List

Fluid Type: Aviation Phosphate Ester, Type IV

Item	Part Number	Description	Qty
1	HC-2149	PRESSURE RELIEF VALVE (Not Set)	1
2	HC-2013-910	O-RING, SERIES 3	1
3	HC-2006-014	O-RING, SERIES 2	1
4	HC-2020-014	BACKUP RING (Teflon)	1
5	HC-2020-015	BACKUP RING (Teflon)	1
6	HC-2006-015	O-RING, SERIES 2	1
7	HC-2020-011	BACKUP RING (Teflon)	2
8	HC-2006-011	O-RING, SERIES 2	1

9.7.3.b Check Valve

The Check Valve does not require regular general maintenance.

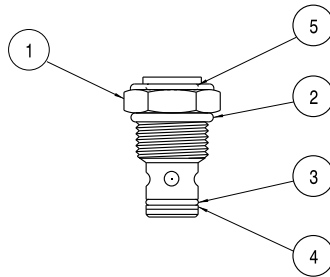

Parts List

Fluid Type: Aviation Phosphate Ester, Type IV

Item	Part Number	Description	Qty
1	HC-1677	CHECK VALVE	1
2	HC-2013-910	O-RING, SERIES 3	1
3	HC-2006-014	O-RING, SERIES 2	1
4	HC-2020-014	BACKUP RING	1
5	HC-2013-905	O-RING, SERIES 3	1

9.7.3.c Bypass Valve

The Bypass Valve does not require regular general maintenance.

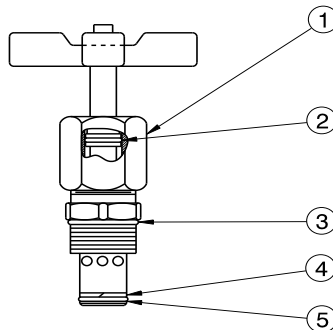

Parts List

Fluid Type: Aviation Phosphate Ester, Type IV

Item	Part Number	Description	Qty
1	HC-1927-05	NEEDLE VALVE	1
2	HC-2006-111	O-RING	1
3	HC-2013-912	O-RING	1
4	HC-2020-114	BACKUP RING	1
5	HC-2006-114	O-RING	1

9.8 RESERVOIR ASSEMBLY

Replace the desiccant air filter whenever the material inside the element is pink or reddish in color (See Element label for details). The Reservoir Assembly does not require regular general maintenance. If periodic inspections for silt are desired, be certain to thoroughly clean the dome cover and surrounding area before removing the dome cover. The Selector Valve (Item 9) is not field serviceable.

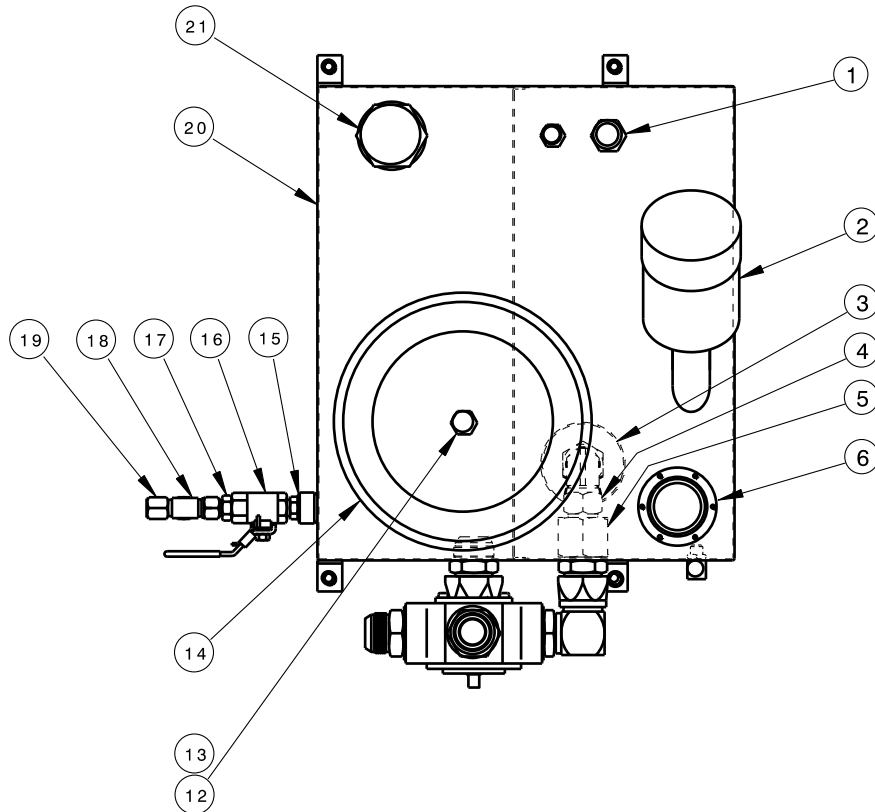

Parts List

Fluid Type: Aviation Phosphate Ester, Type IV

Item	Part Number	Description	Qty
1	N-2008-08-S	CAP, #12	1
2	HC-1763	DESICCANT FILTER	1
3	HC-1397-02	DIFFUSER, 1" NPT	1
4	N-2035-08-S	ELBOW, SWIVEL MALE, #16 JIC X 1" NPT	1
5	N-2055-25-S	TUBE REDUCER, #20 X #16 JIC	1
6	HC-2193-06	FILLER, NON-VENTED	1
12	H-1735-02	WASHER, NYLON	1
13	G-1100-110016	BOLT, HEX HEAD, GRADE 5, 5/8-11 X 1 3/4" LONG	1
14	H-1741	COVER ASSEMBLY	1
15	HC-2013-908	O-RING, SERIES 3	1
16	HC-1761	BALL VALVE, SAE #8 LOCKABLE	1
17	N-2007-11-S-E	CONNECTOR, STRAIGHT THREAD #8 SAE X #8 JIC	1
18	N-2016-06-S-E	TEE, SWIVEL RUN, #8 JIC	1
19	N-2008-06-S	CAP, #8	3
20	Z-5525	RESERVOIR, 30 GALLON (113.4 LT)	1
21	N-2206-09-S	PLUG, HEX HEAD, 2" NPT	1

9.8 RESERVOIR ASSEMBLY (continued)

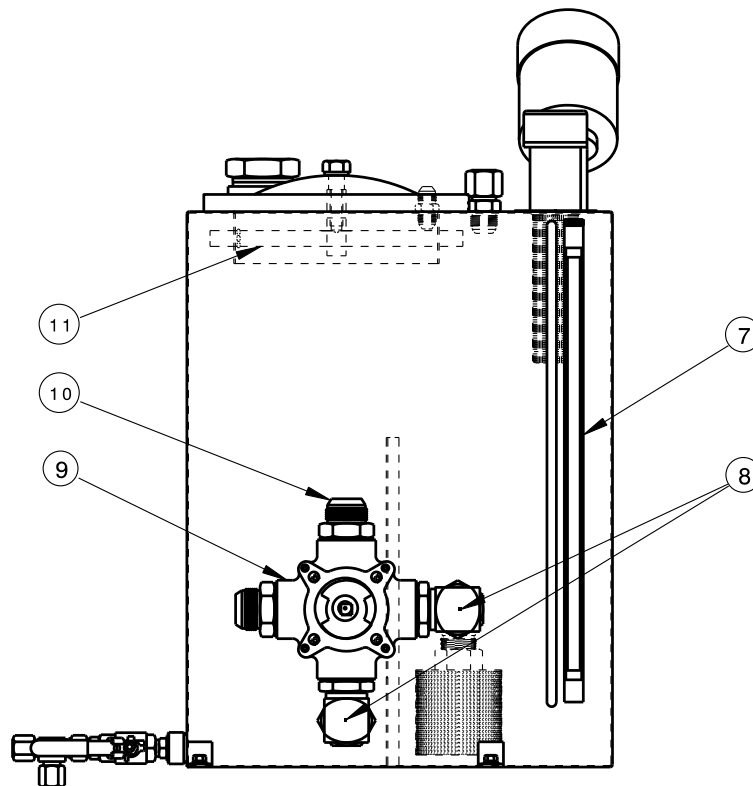

Parts List

Fluid Type: Aviation Phosphate Ester, Type IV

Item	Part Number	Description	Qty
7	HC-1383-18	SIGHT GAUGE	1
8	N-2049-20-S-E	ELBOW, 90° SWIVEL, #20	2
9	HC-1764-02	SELECTOR VALVE, #20 SAE	1
10	N-2007-28-S-E	CONNECTOR, STRAIGHT THREAD #20 SAE	2
11	Z-2394-01	CLAMP ASSEMBLY	1

9.9 RETURN MANIFOLD ASSEMBLY

The Return Manifold does not require regular general maintenance.

NOTE: DO NOT attempt to adjust the Return System Pressure Relief Valve. See Section 9.9.1 – Return System Pressure Relief Valve for details.

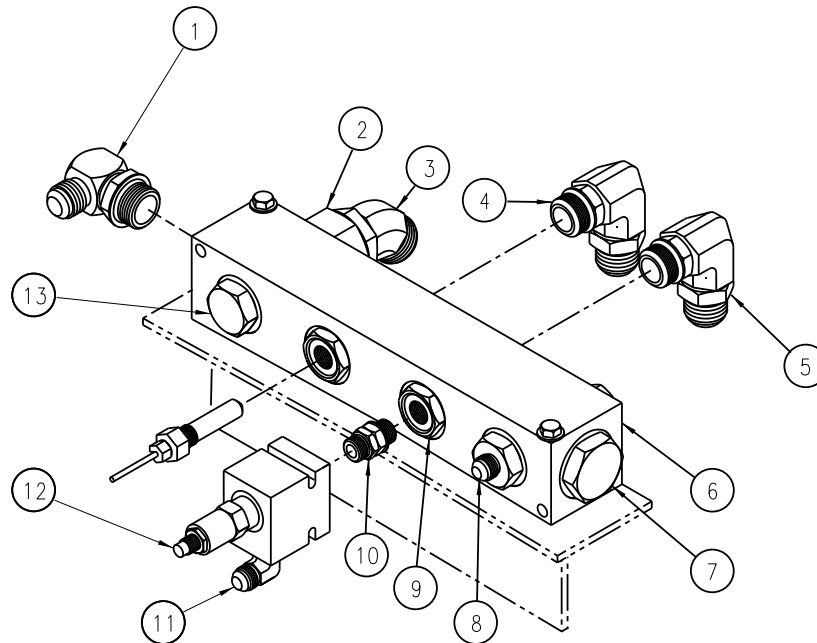

Parts List

Fluid Type: Aviation Phosphate Ester, Type IV

Item	Part Number	Description	Qty
1	N-2001-37-S-E	ELBOW, STRAIGHT #12 JIC X #20 SAE	1
2	N-2463-18-S-E	REDUCER/EXPANDER FITTING, 16/20 SAE	1
3	N-2042-13-S-E	ELBOW, 45° STRAIGHT THREAD #20 SAE X #20 JIC	1
4	N-2638-06-S-E	ELBOW, 90° #16 SAE X #16 SAE	2
5	N-2007-21-S-E	CONNECTOR, STRAIGHT THREAD #16 SAE X #12 JIC	2
6	HC-1916	RETURN MANIFOLD	1
7	N-2053-11-S-E	O-RING PLUG, HEX HEAD, #20	1
8	N-2007-21-S-E	CONNECTOR, STRAIGHT THREAD #16 SAE X #12 JIC	1
9	N-2463-16-S-E	REDUCER/EXPANDER FITTING, 16/8 SAE	2
10	N-2464-06-S-E	UNION, STRAIGHT THREAD #8 X #8 SAE	1
11	N-2001-11-S-E	ELBOW, STRAIGHT THREAD, #8 SAE X #8 JIC	1
12	HC-2200	PRESSURE RELIEF VALVE (Pre-set)	1
13	N-2053-10-S-E	O-RING PLUG, HEX HEAD #16	2

9.9.1 Return System Pressure Relief Valve

The Return System Pressure Relief Valve can be purchased as a preset assembly. If the relief valve is serviced by the end user, the valve must be set to crack at 150+/-7 psig **before** being re-installed on the HPU.

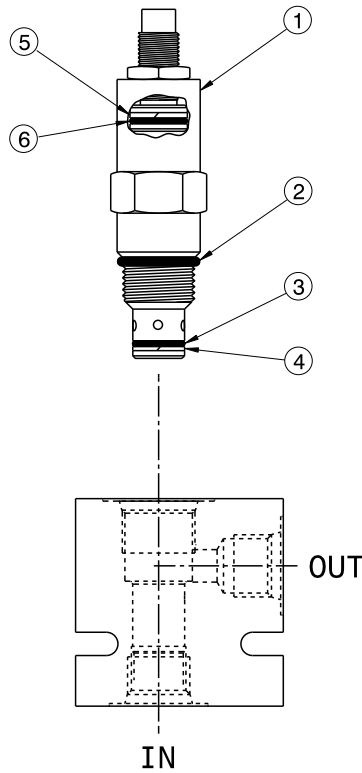

Parts List

Fluid Type: Aviation Phosphate Ester, Type IV

Item	Part Number	Description	Qty
1	HC-2200	PRESSURE RELIEF VALVE (includes Valve Block)	1
2	HC-2013-910	O-RING, SERIES 3	1
3	HC-2006-014	O-RING, SERIES 2	1
4	HC-2020-014	BACKUP RING (Teflon)	1
5	HC-2020-015	BACKUP RING (Teflon)	1
6	HC-2006-015	O-RING, SERIES 2	1

This page left blank intentionally

9.10 ELECTRICAL COMPONENTS

Regularly inspect the external power cord for nicks, cuts, abrasion, and fluid damage. Replace power cord if damage is found. See Section **10.0 – Provision of Spares** for recommended spare fuses.

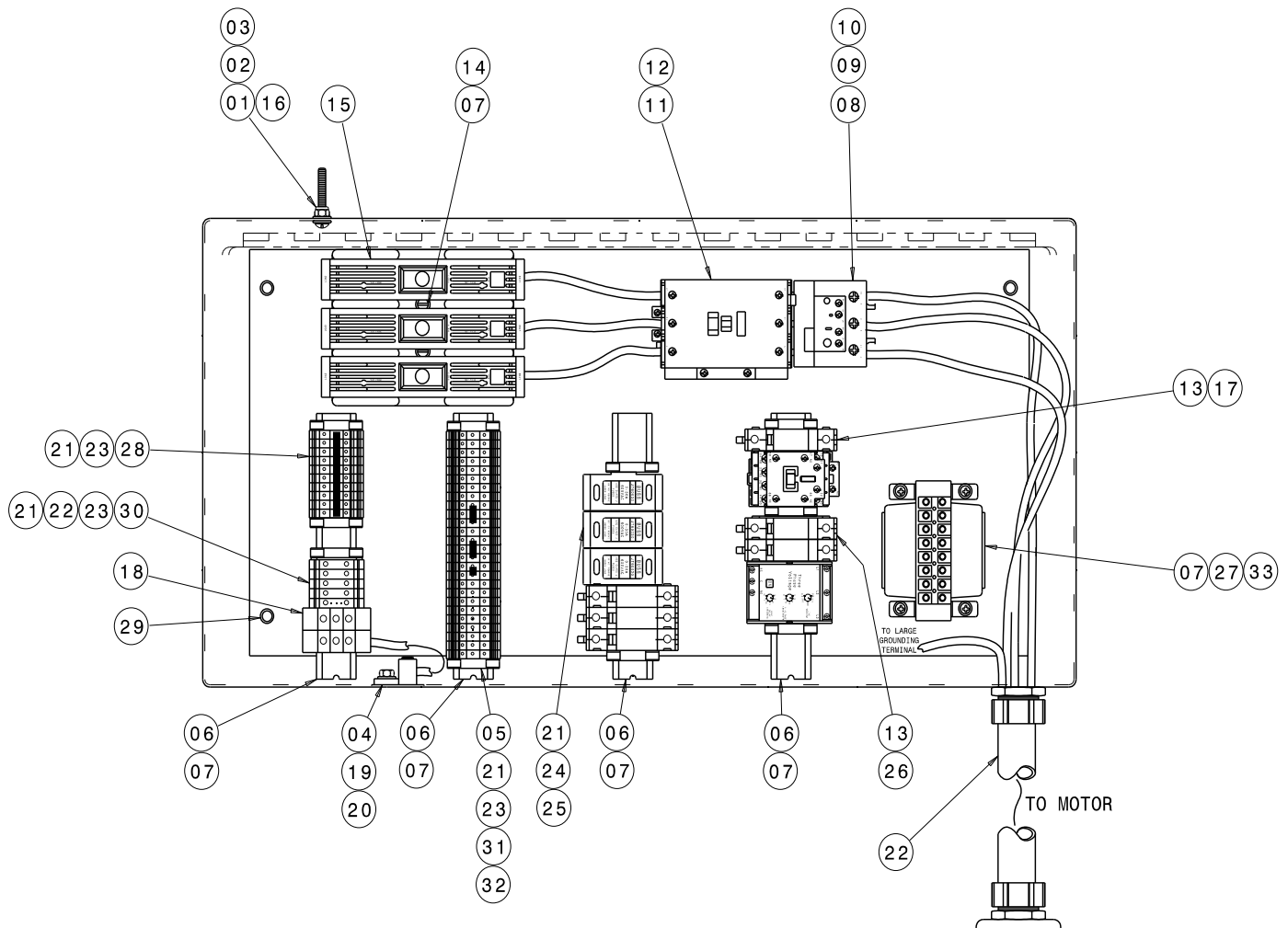

Set Item 07 to "Auto" and set "A2" to its corresponding full load amps. Wire per Appendix - Electrical Schematic INS-1608 and wire diagram INS-1746.

Parts List

Fluid Type: Aviation Phosphate Ester, Type IV

Item	Part Number	Description	Qty
1	G-1159-105516	SCREW, RD HD CRS REC, ¼ - 28 X 1 ¾ LONG	1
2	G-1250-1050N	FLATWASHER, ¼ NARROW	2
3	G-1202-1055	ESN, ¼ - 28	1
4	G-1180-105006	SCREW, ¼ HH TYPE F	1
5	EC-1956-02	BLOCK, IEC TERMINAL (RED)	26
6	EC-1803	RAIL, DIN	4
7	G-1150-103506	SCREW, #10-32 HH MACH X ¾ LONG	14
9	EC-1603	SHIELD, ANTI-TAMPER	1
10	EC-1604	SHIELD, CURRENT ADJUSTMENT	1
12	EC-1607	LUG SET, TERMINAL	1
13	EC-1541-01	FUSE HOLDER, IEC CLASS CC	3

9.10 ELECTRICAL COMPONENTS (continued)

Parts List

Fluid Type: Aviation Phosphate Ester, Type IV

Item	Part Number	Description	Qty
16	EC-1180-24	TERMINAL, RING TONGUE ¼ BOLT HOLE	7
17	EC-1542-04	FUSE, LP-CC-LOW PEAK 1-6/10A	1
18	EC-1957	BLOCK, IEC GROUND	2
19	EC-1532-02	LUG, GROUND	1
20	G-1251-1050R	LOCKWASHER, ¼ REGULAR	5
21	EC-1959	ANCHOR, IEC END	10
22	EC-1958	BLOCK, IEC GROUND	5
23	EC-1960-01	BARRIER, END	2
24	EC-1596-01	FUSE HOLDER, CLASS J	3
27	EC-1804-02	TRANSFORMER, CONTROL (100 W)	1
28	EC-1956-03	BLOCK, IEC TERMINAL (BLUE)	10
29	G-1202-1070	ESN, ⅝ – 16	4
30	EC-1961-04	JUMPER, CENTER	1
31	EC-1961-02	JUMPER, CENTER	2
32	EC-1961-01	JUMPER, CENTER	1
33	EC-1826	GUARD, FINGER TOUCHPROOF	1

THE FOLLOWING PARTS ARE APPLICATION SPECIFIC

Be sure to locate the correct voltage and hertz of the unit before selecting the part

Item	60 HZ Applications					Description	Qty
	208	230	380	460	575		
8	EC-1525	EC-1589	EC-1589	EC-1589	EC-1589	RELAY, OVERLOAD	1
11	EC-1842	EC-1586	EC-1586	EC-1586	EC-1586	CONTACTOR, IEC MOTOR	1
14	EC-1563	EC-1563	EC-1563	EC-1674	EC-1674	FUSE BLOCK, CLASS J	1
15	EC-1557-30	EC-1557-30	EC-1557-27	EC-1557-25	EC-1557-24	FUSE, CLASS J	3
25	EC-1557-02	EC-1557-02	EC-1557-01	EC-1557-01	EC-1557-04	FUSE, CLASS J	3
26	EC-1726-09	EC-1726-08	EC-1726-05	EC-1726-04	EC-1726-04	FUSE, CLASS CC	2

Item	50 HZ Applications					Description	Qty
	200	220	380	415	440		
8	EC-1525	EC-1589	EC-1589	EC-1589	EC-1589	RELAY, OVERLOAD	1
11	EC-1842	EC-1586	EC-1586	EC-1586	EC-1586	CONTACTOR, IEC MOTOR	1
14	EC-1563	EC-1563	EC-1674	EC-1674	EC-1674	FUSE BLOCK, CLASS J	1
15	EC-1557-31	EC-1557-31	EC-1557-26	EC-1557-26	EC-1557-26	FUSE, CLASS J	3
25	EC-1557-04	EC-1557-04	EC-1557-01	EC-1557-01	EC-1557-04	FUSE, CLASS J	3
26	EC-1726-10	EC-1726-09	EC-1726-05	EC-1726-05	EC-1726-04	FUSE, CLASS CC	2

9.10.1 Electrical Components With 100 ft Input Cord Option

Regularly inspect the external power cord for nicks, cuts, abrasion, and fluid damage. Replace power cord if damage is found. See Section 11.0 Provision of Spares for recommended spare fuses.

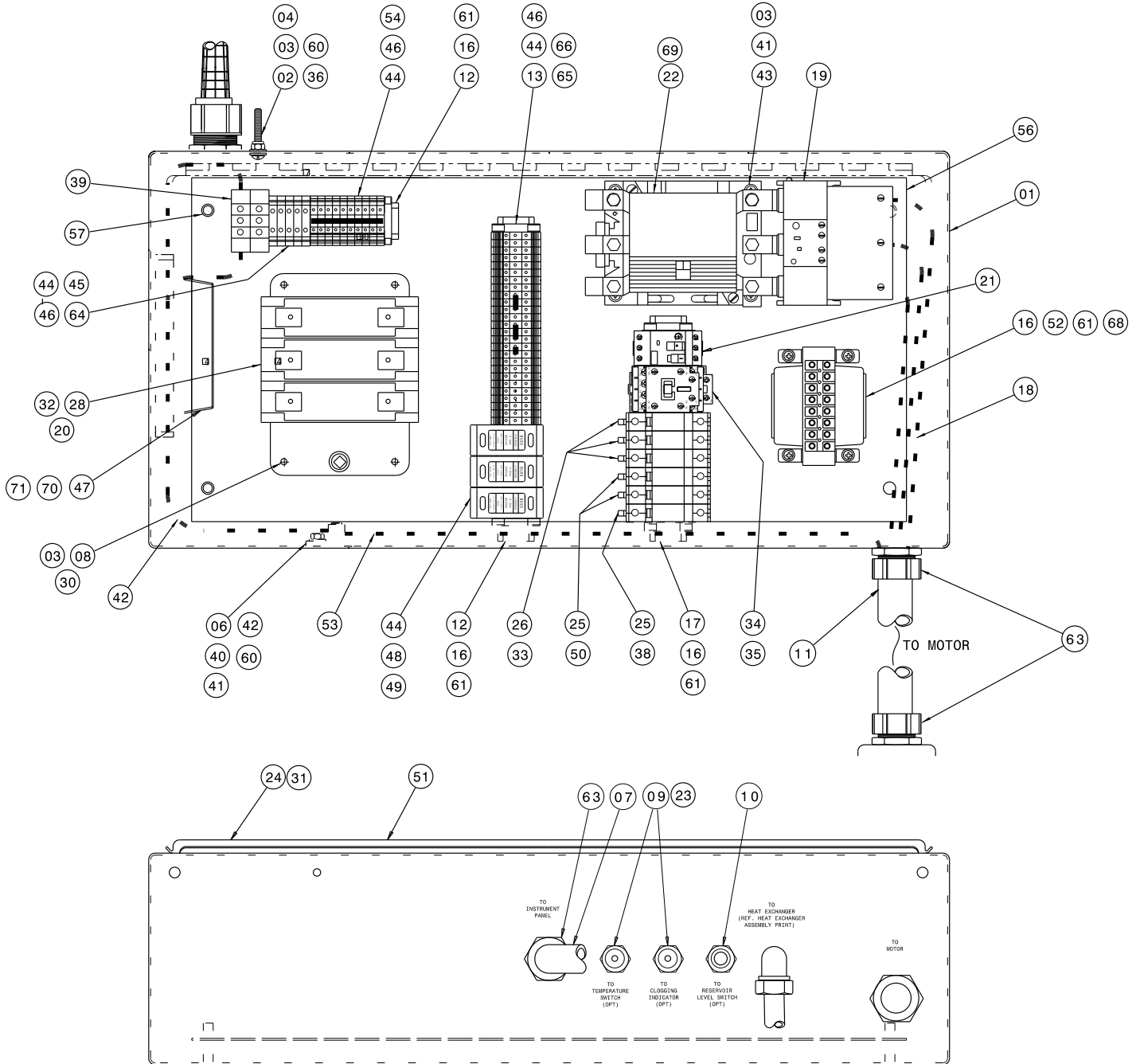

Set Item 09 to "Auto" and set "A2" to its corresponding full load amps. Wire per Electrical Schematic INS-2016. Reference Wire Diagram INS-2144.

9.11.1 Electrical Components With 100 ft. Input Cord Option (continued)

Parts List

Fluid Type: Aviation Phosphate Ester, Type IV

Item	Part Number	Description	Qty
1	EC1897	ENCLOSURE, ELECTRICAL	1
2	G-1159-105516	SCREW, RD HD CRS REC, ¼ - 28 X 1 ¾ LONG	1
3	G-1250-1050N	FLATWASHER, ¼ NARROW	10
4	G-1202-1055	ESN, ¼ - 28	1
6	G-1180-105006	SCREW, ¼ HH TYPE F	1
7	EC-1187-06*16.0	CONDUIT, FLEXIBLE WIRING, 1"	1
8	G-1159-102006	HARDWARE, MOUNTING	4
9	EC-1175-06-A	CONNECTOR, POWER CABLE	2
11	EC-1187-06*21.8	CONDUIT, FLEXIBLE WIRING, 1"	1
12	EC-1895-008.90	RAIL, DIN	2
13	EC-1956-02	BLOCK, IEC TERMINAL (RED)	26
15	EC-1803	RAIL, DIN	4
16	G-1150-103504	SCREW, #10-32 HH MACH X ¼ LONG	10
17	EC-1895-012.25	RAIL, DIN	1
18	EC-1263-08*50.0	WIRE, POWER (4 AWG, BLACK)	3
24	V-2293	LABEL, CIRCUIT CAPABLE	1
25	EC-1541-01	FUSE HOLDER, IEC CLASS CC	3
27	EC-1263-08*12.0	WIRE, POWER (2 AWG, BLACK)	3
28	EC-1894	SWITCH, FUSED DISCONNECT	1
30	G-1250-1020N	FLATWASHER, #8 NARROW	4
31	V-2294	LABEL, DANGER	1
36	EC-1180-24	TERMINAL, RING TONGUE ¼ BOLT HOLE	7
37	EC-1572-01*108	WIRE, GREEN/YELLOW	2
38	EC-1542-09	FUSE, LP-CC-LOW PEAK 1-6/10A	1
39	EC-1957	BLOCK, IEC GROUND	2
40	EC-1532-02	LUG, GROUND	1
41	G-1251-1050R	LOCKWASHER, ¼ REGULAR	5
42	EC-1572-08*24.0	WIRE, GROUND (2 AEG, GREEN/YELLOW)	1
43	G-1159-103510	SCREW, RD HD CRS REC, #10-32 X 1 ¾ LONG	6
44	EC-1959	ANCHOR, IEC END	5
45	EC-1958	BLOCK, IEC GROUND	5
46	EC-1960-01	BARRIER, END	2
48	EC-1596-01	FUSE HOLDER, CLASS J	3
51	V-2413	LABEL, FUSE ID	1
53	EC-1572-08*120	WIRE, GROUND (2 AEG, GREEN/YELLOW)	1
54	EC-1956-03	BLOCK, IEC TERMINAL (BLUE)	10
55	S-2012	PANEL, INNER	1
57	G-1202-1070	ESN, ⅜ - 16	4
60	V-1665	LABEL, GROUND	2
61	G-1250-1030N	FLATWASHER, #10 NARROW	10
63	EC-1167-04	CONNECTOR, CONDUIT	1

9.11.1 Electrical Components With 100 ft. Input Cord Option (continued)

Parts List

Fluid Type: Aviation Phosphate Ester, Type IV

Item	Part Number	Description	Qty
64	EC-1961-04	JUMPER, CENTER	1
65	EC-1961-02	JUMPER, CENTER	2
66	EC-1961-01	JUMPER, CENTER	1
68	EC-1826	GUARD, FINGER TOUCHPROOF	1
69	EC-1607	AUX SWITCH, BLACK	1
N/S	H-2432-06	PLUG, SHEETMETAL	3
N/S	EC-1666	HARNESS, WIRING	1
N/S	V-1978	LABEL, COMPONENT GROUP	1

THE FOLLOWING PARTS ARE APPLICATION SPECIFIC

Be sure to locate the correct voltage and hertz of the unit before selecting the part

Item	60 Hz Applications					Description	Qty
	208	230	380	460	575		
19	EC-1525	EC-1589	EC-1589	EC-1589	EC-1589	RELAY, OVERLOAD	1
20	N/A	N/A	EC-1602-01	EC-1602-01	EC-1602-01	REDUCER, FUSE	3
21	EC-2465	EC-2465	EC-2330	EC-2330	EC-2330	OVERLOAD, MONITOR	1
22	EC-1587	EC-1586	EC-1586	EC-1586	EC-1586	CONTACTOR, IEC MOTOR	1
32	EC-1557-31	EC-1557-30	EC-1557-26	EC-1557-25	EC-1557-24	FUSE, CLASS J	3
49	EC-1557-02	EC-1557-02	EC-1557-01	EC-1557-01	EC-1557-01	FUSE, CLASS J	3
50	EC-1726-09	EC-1726-08	EC-1726-05	EC-1726-04	EC-1726-04	FUSE, CLASS CC	2
52	EC-1804-02	EC-1676-02	EC-1804-02	EC-1676-02	EC-1804-02	TRANSFORMER, CONTROL (100 VA)	1

Item	50 Hz Applications					Description	Qty
	200	220	380	415	440		
19	EC-1525	EC-1525	EC-1589	EC-1589	EC-1589	RELAY, OVERLOAD	1
20	N/A	N/A	EC-1602-01	EC-1602-01	EC-1602-01	REDUCER, FUSE	3
21	EC-2465	EC-2465	EC-2330	EC-2330	EC-2330	OVERLOAD, MONITOR	1
22	EC-1587	EC-1587	EC-1586	EC-1586	EC-1586	CONTACTOR, IEC MOTOR	1
32	EC-1557-31	EC-1557-30	EC-1557-26	EC-1557-26	EC-1557-26	FUSE, CLASS J	3
49	EC-1557-04	EC-1557-04	EC-1557-01	EC-1557-01	EC-1557-01	FUSE, CLASS J	3
50	EC-1726-10	EC-1726-09	EC-1726-05	EC-1726-05	EC-1726-04	FUSE, CLASS CC	2
52	EC-1804-02	EC-1804-02	EC-1804-02	EC-1804-02	EC-1804-02	TRANSFORMER, CONTROL (100 VA)	1

9.11 HEAT EXCHANGER ASSEMBLY

The Heat Exchanger Assembly does not require regular general maintenance.

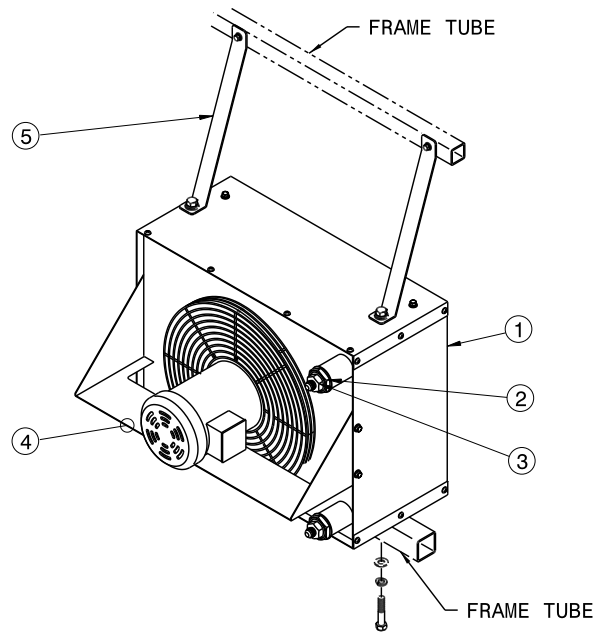

Parts List

Fluid Type: Aviation Phosphate Ester, Type IV

Item	Part Number	Description	Qty
1	Reference Table below	HEAT EXCHANGER	1
2	N-2463-20-S-E	REDUCER, #20 X #12 SAE	1
3	N-2007-18-S-E	CONNECTOR, #12 JIC FLARE	2
4	N-2066-20-S-E	PLUG, #20 SAE (HIDDEN)	1
5	J-3403-01	STRAP	2

Voltage	Frequency	Part Number
208v	60 Hz	HC-2136-01
230v	60 Hz	HC-2136-01
380v	60 Hz	HC-2136-01
460v	60 Hz	HC-2136-01
575v	60 Hz	HC-2136-02
200v	50 Hz	HC-2136-01
220v	50 Hz	HC-2136-01
380v	50 Hz	HC-2136-01
415v	50 Hz	HC-2136-01
440v	50 Hz	HC-2136-01

9.12 EXTERNAL COMPONENTS

Keep HPU clean. Do not allow labels to become damaged; thusly illegible. Regularly inspect casters and floor locks to ensure safe working condition.

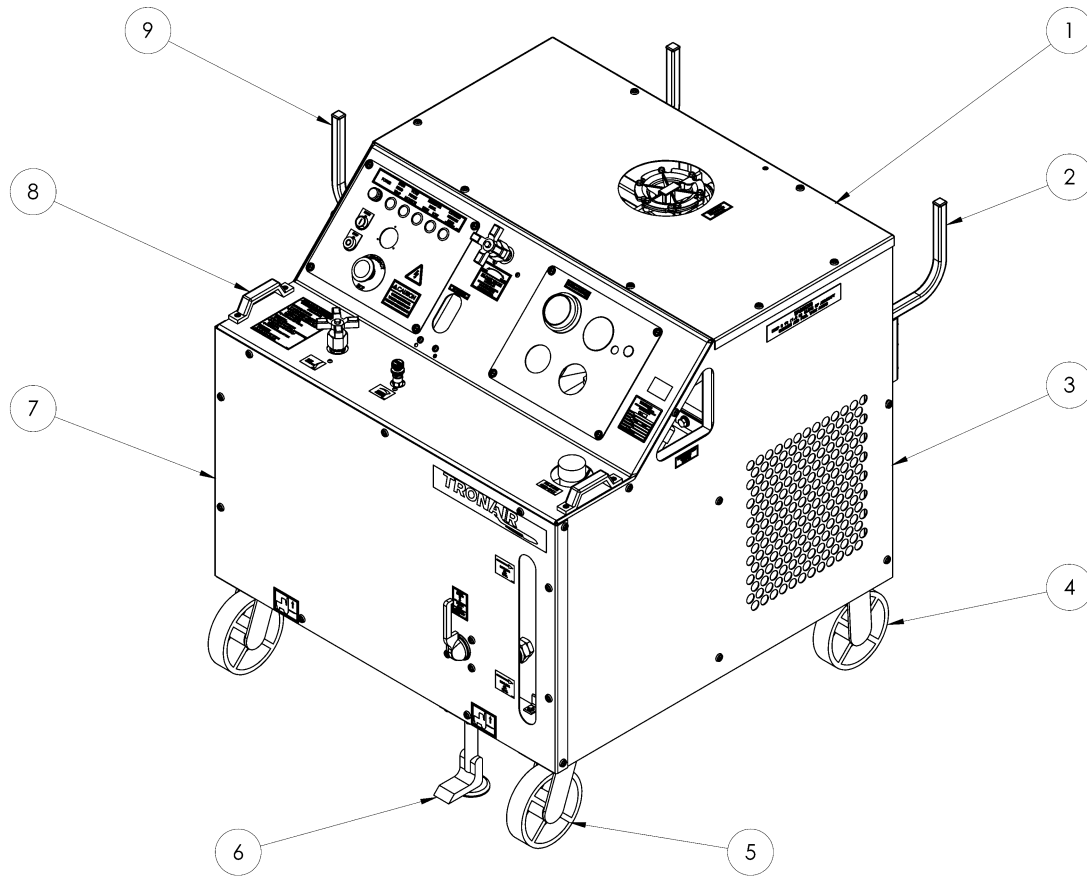

Parts List

Fluid Type: Aviation Phosphate Ester, Type IV

Item	Part Number	Description	Qty
1	S-1889-00	TOP PANEL	1
2	Z-5772-00	HANGER	3
3	S-3953-00	RIGHT SIDE PANEL	1
4	U-1093	RIGID CASTER	2
5	U-1094	SWIVEL CASTER	2
6	H-1142	FLOOR LOCK	1
7	Z-11052-00	FRONT PANEL	1
8	H-1780	HANDLE	2
9	Z-5549-00	CORD HANGER	1
N/S	Z-11301	LEFT SIDE PANEL	1
N/S	Z-5775-00	FRAME	1

9.13 SPLIT SYSTEM ASSEMBLY

Refer to Section **9.6 Hydraulic Hoses** concerning hose inspection.

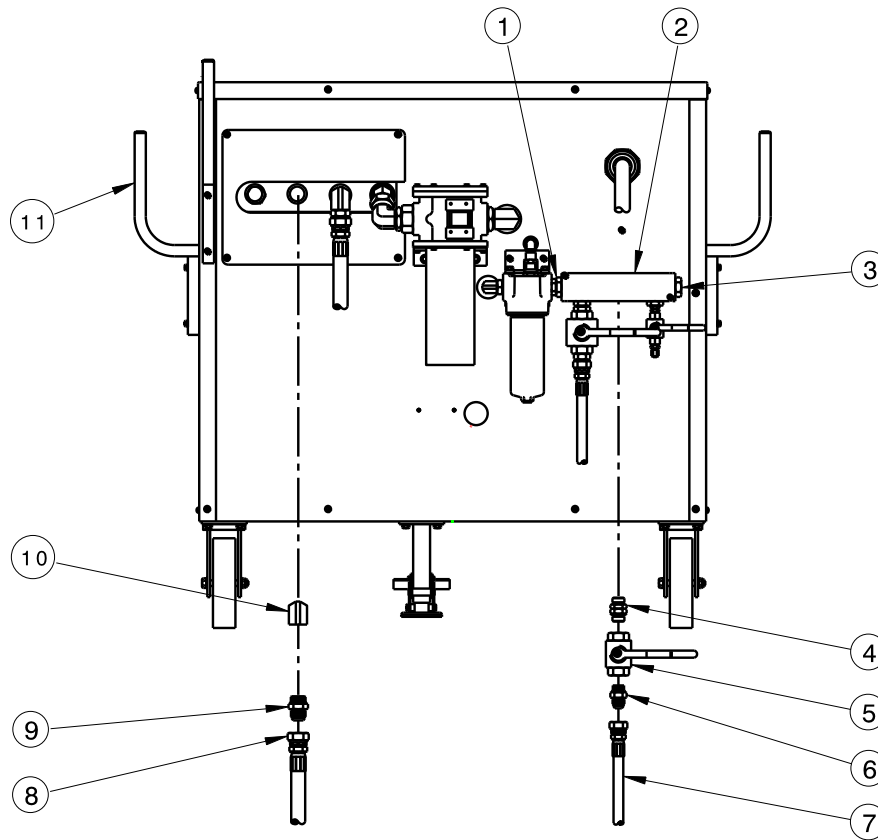

Parts List

Fluid Type: Aviation Phosphate Ester, Type IV

Item	Part Number	Description	Qty
1	N-2464-14-S-E	UNION, MALE STRAIGHT THREAD #12 X #16	1
2	HC-1908	PRESSURE MANIFOLD (PLATED)	1
3	N-2053-10-S-E	PLUG, MALE STRAIGHT THREAD #16	1
4	N-2464-08-S-E	UNION, MALE STRAIGHT THREAD #12	2
5	HC-1771-04	BALL VALVE	2
6	N-2007-14-S-E	CONNECTOR, STRAIGHT THREAD #12 X #12 JIC	2
7	TF-1040-09*300	PRESSURE HOSE ASSEMBLY, #12	3
8	TF-1041-15*300	RETURN HOSE ASSEMBLY, #16	3
9	N-2007-21-S-E	CONNECTOR, STRAIGHT THREAD #16 X #16 JIC	2
10	N-2638-06-S-E	ELBOW, 90° #16 M-SAE X #16 F-SAE	2
11	Z-5549-01	WELDMENT, HOSE HANGER	4

9.14 ELECTRIC FILTER CLOGGING INDICATOR

The Electric Filter Clogging Indicator does not require regular general maintenance. The panel light will illuminate when the clogging indicator senses a 50 psi differential pressure across the filter element. Installing a new filter element will eliminate the clogged condition. Pushing the illuminated button will reset the indicator light.

NOTES:

- 1) Higher flow rates will result in higher differential pressures. (Example: The clogging indicator may sense a 50 psi differential pressure at a flow rate of 10 gpm but not show a clogged condition when the flow rate is reduced to 5 gpm.)
- 2) Wire per Electrical Schematic INS-1608. Reference Wiring Diagram INS-1746. Reference 9.7.1 Electric Panel for Panel Light.

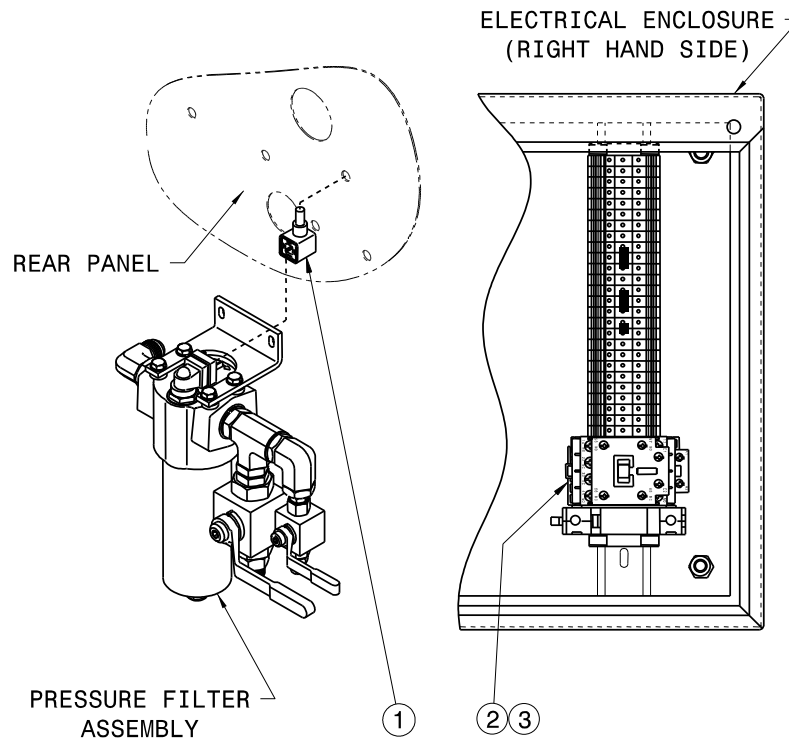

Parts List

Item	Part Number	Description	Qty
1	EC-1778	DIN CONNECTOR CABLE	3
2	EC-1564	RELAY, CONTROL	3
3	EC-1591-04	LATCH, MECHANICAL	1

9.15 ADDITIONAL FEATURES

9.15.1 Voltage/Phase Monitor (*Options G – J*)

The Voltage/Phase Monitor does not require regular general maintenance. The panel indicator light will illuminate if a tripped condition exists. If the Voltage/Phase Monitor is causing the HPU to shut off, verify the ♦Phase Monitor settings shown. Continued tripping may indicate a serious electrical problem. See Section **10.0 – Provision of Spares** for recommended spare fuses.

NOTE: Wire per Electrical Schematic INS-1608. Reference Wiring Diagram INS-1746. Reference Section 9.7.1 Electrical Panel for Panel Light.

PHASE MONITOR

Option	Voltage	Frequency	Part Number
G	200 – 230	50/60 Hz	EC-1543-02
H	380	50/60 Hz	EC-1543-03
I	415 – 460	50/60 Hz	EC-1543-04
J	575	60 Hz	EC-1543-05

♦ Setting Instructions for Item 3:

1. Set **Line Voltage** to match the voltage rating of the Hydraulic Power Unit.
2. Set **% Voltage Unbalanced** to 5% for 60 Hz unit or 6% for 50 Hz unit.
3. Set **Trip Delay** to three (3) seconds.

9.15.2 Electric Reservoir Level (Option L)

The Electric Reservoir Level switch does not require regular general maintenance. Panel indicator lights will indicate low or high fluid level.

NOTE: Wire per Electrical Schematic INS-1608. Reference Wiring Diagram INS-1608. Reference 9.7.1 Electrical Panel for Panel Light.

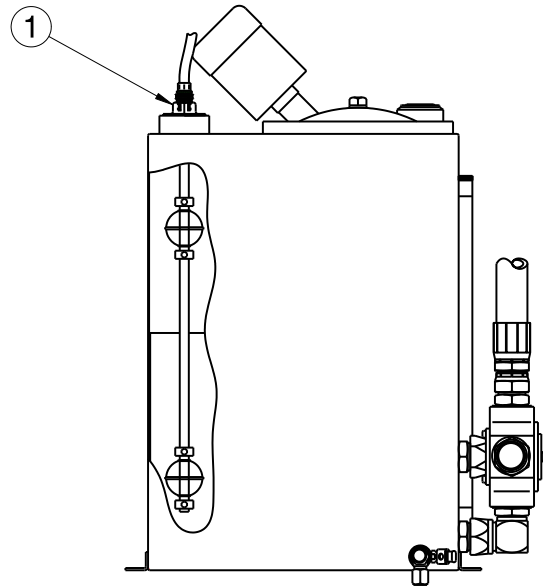

Parts List

Fluid Type: Aviation Phosphate Ester, Type IV

Item	Part Number	Description	Qty
1	EC-1798	MULTI-LEVEL SWITCH (includes Plug-in Cable)	1

This page left blank intentionally.

9.15.3 Hand Pump (Option M)

Refer to Section **9.6 Hydraulic Hoses** concerning hose inspection for general maintenance on Items 5, 10, 12, and 14 hose assemblies. Refer to Section **9.5.3 – Hand Pump (Optional) Filter**.

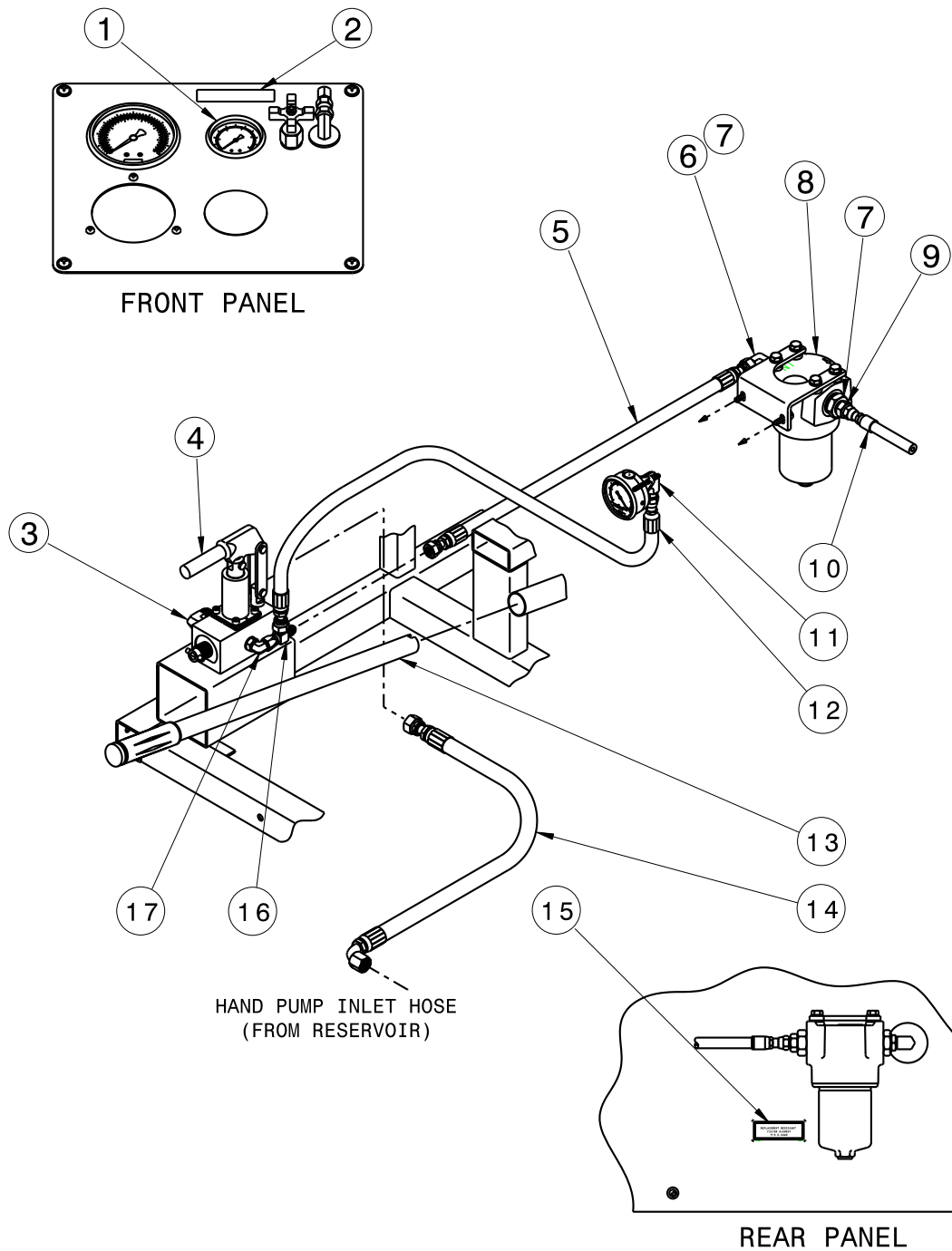

9.15.3 Hand Pump (Option M) (continued)

Parts List

Fluid Type: Aviation Phosphate Ester, Type IV

Item	Part Number	Description	Qty
1	HC-2146	PRESSURE GAUGE	1
2	V-1887	LABEL, HAND PUMP PRESSURE	1
3	N-2001-11-S-E	ELBOW, #8 SAE X #8 JIC FLARE	1
4	HC-1779	HAND PUMP, TWO STAGE	1
5	TF-1041-05*66.0	HOSE ASSEMBLY, #4	1
6	N-2001-09-S-E	ELBOW, #8 SAE X #6 JIC FLARE	1
7	N-2463-10-S-E	REDUCER FITTING	2
8	HC-1777	PRESSURE FILTER	1
9	N-2007-06-S-E	FITTING, MALE CONNECTOR	1
10	TF-1041-05*180	HOSE ASSEMBLY, #4	1
11	N-2002-03-S	ELBOW, SWIVEL NUT	1
12	TF-1041-05*54.0	HOSE ASSEMBLY, #4	1
13	H-1009-01	PUMP HANDLE	1
14	TF-1041-25*32.5	HOSE ASSEMBLY, #8	1
15	V-1989	LABEL, FILTER REPLACEMENT	1
16	N-2016-05-S	TEE, SWIVEL NUT, #6	1
17	N-2001-08-S-E	ELBOW, #6 SAE X #6 JIC FLARE	1

9.15.3.a Two Stage Pump with Relief

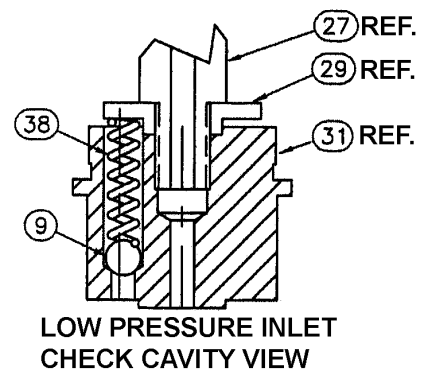
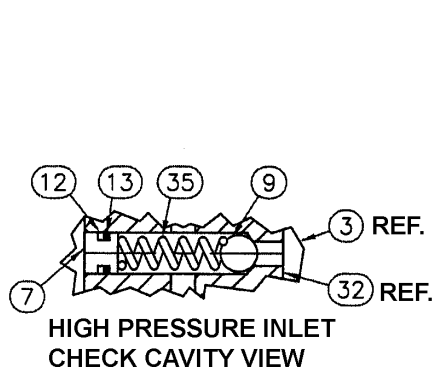
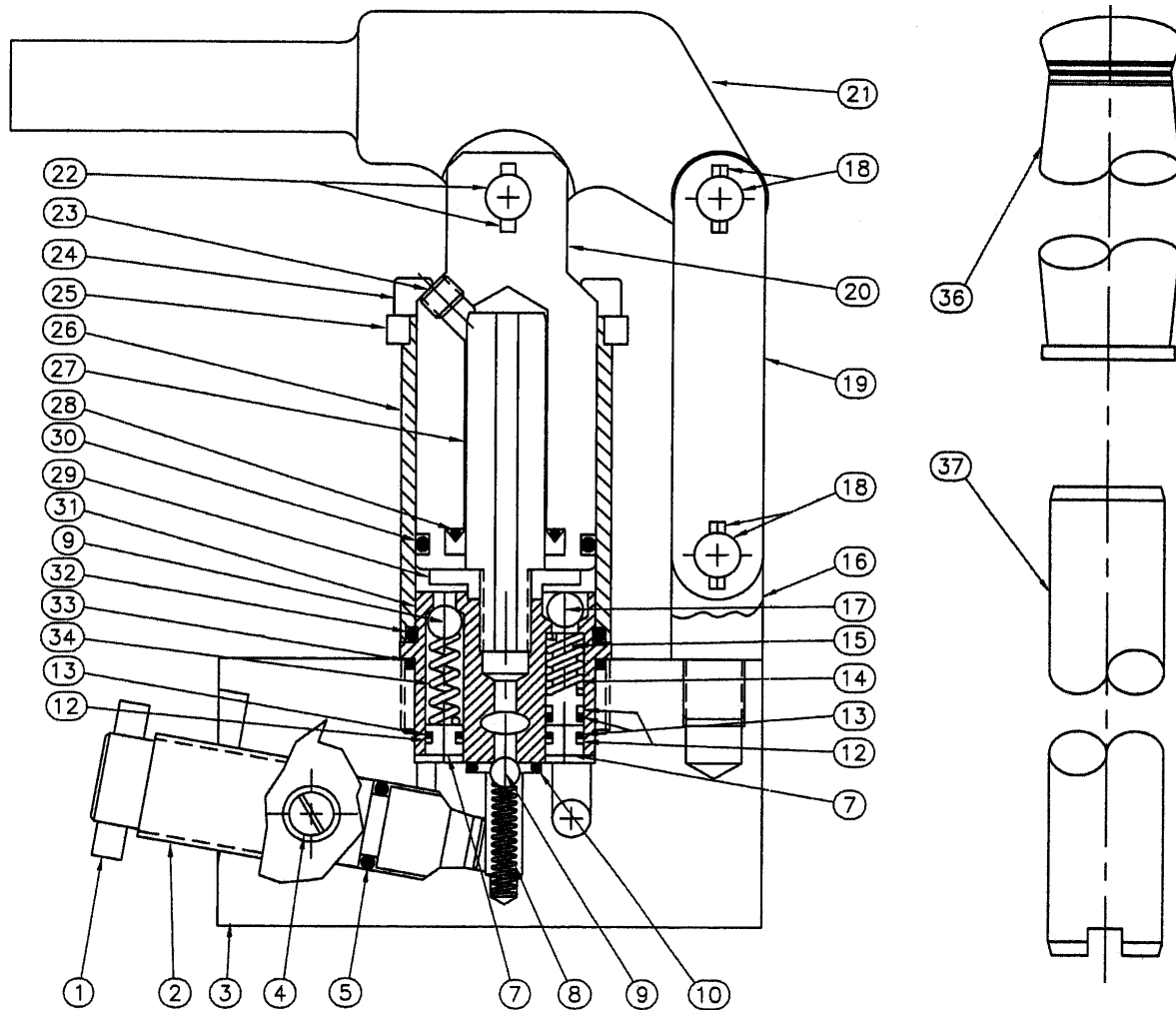

9.15.3.a Two Stage Pump with Relief (continued)

Parts List

Fluid Type: Aviation Phosphate Ester, Type IV

Item	Part Number	Description	Qty
1	519-000	PIN	1
3	CXC-990022-001	BODY	1
7	505-001	PLUG, VALVE BODY	3
15	571-121	PISTON, BYPASS ASSEMBLY	1
16	508-000	PIVOT	1
20	566-125	PISTON L.P	1
23	583-120	PLUG	1
24	09-ADDF-04-20 X 56	TIE ROD	4
25	582-125	FLANGE	1
26	563-121	TUBE	1
27	562-125	H.P. PISTON	1
29	564-120	RETAINER	1
31	560-120	VALVE BODY	1
36	H-1223	GRIP, HANDLE	1
37	H-1009-01	HANDLE WITH GRIP	1
	HK-1095	KIT, INTERNAL PARTS; consists of:	
6	(Not Shown)	BALL, RELEASE	0
8		SPRING, OUTLET CHECK	1
9		BALL, CHECK	4
14		SPRING, BYPASS	1
17		BALL, BYPASS	1
34		SPRING, L.P. OUTLET	1
35		SPRING, H.P. OUTLET	1
38		SPRING, INTAKE LP	1
	HK-1030	KIT, PUMP SEAL; consists of:	
5		O-RING, EPR	1
10		O-RING, EPR	1
12		BACKUP RING (Teflon)	4
13		O-RING, EPR	4
28		H.P. PISTON SEAL	1
30		O-RING, EPR	1
32		O-RING, EPR	1
33		O-RING, EPR	1
	HK-1068	KIT, PUMP LINKAGE; consists of:	
18		PIN LINKAGE ASSEMBLY	2
19		STRAP	2
21		HANDLE BRACKET	1
22		CLEVIS PIN ASSEMBLY	1
	HK-3117	KIT, RELEASE SCREW; consists of:	
2		SCREW, RELEASE/RELIEF	1
4		RETAINER, RELEASE SCREW	1

9.15.4 Calibration Port (Option Q)

Refer to Section 9.6 **Hydraulic Hoses** concerning hose inspection.

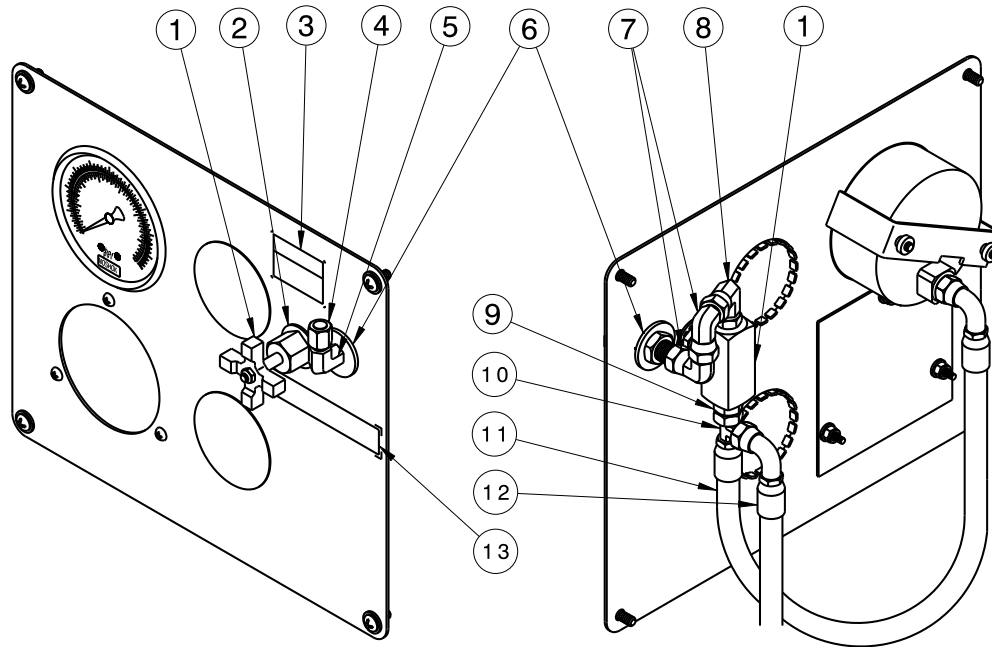

Parts List

Fluid Type: Aviation Phosphate Ester, Type IV

Item	Part Number	Description	Qty
1	HC-1900-02	NEEDLE VALVE	1
2	HC-1122	KIT, PANEL MOUNTING (MVK-4)	1
3	V-1470	LABEL, CAUTION	1
4	N-2008-03-S	CAP, ¼, #4 JIC	1
5	N-2022-03-S	ELBOW, BULKHEAD UNION WITH LOCKNUT #4	1
6	G-1250-1080W	FLATWASHER, 7/16 WIDE	2
7	N-2002-03-S	ELBOW, SWIVEL NUT #4	2
8	N-2049-07-S-E	ELBOW, 90° SWIVEL & O-RING #4 X #6	1
9	N-2007-03-S-E	CONNECTOR, STRAIGHT THREAD #4	1
10	N-2016-03-S	TEE, SWIVEL NUT RUN, #4	1
11	TF-1041-49*16.0	HOSE ASSEMBLY, #4	1
12	TF-1040-42*32.0	HOSE ASSEMBLY, #4	Ref
13	V-1888	LABEL, SHUT-OFF CALIBRATION	1

9.15.5 Electric Over-Temperature (*Option S*)

The Electric Over-Temperature switch does not require regular general maintenance. However, automatic shut down due to high fluid temperature is a indication that maintenance or training may be needed elsewhere.

NOTE: Wire per Electrical Schematic INS-1608. Reference Wiring Diagram INS-1746. Reference 9.7.1 Electric Panel for Panel Light.

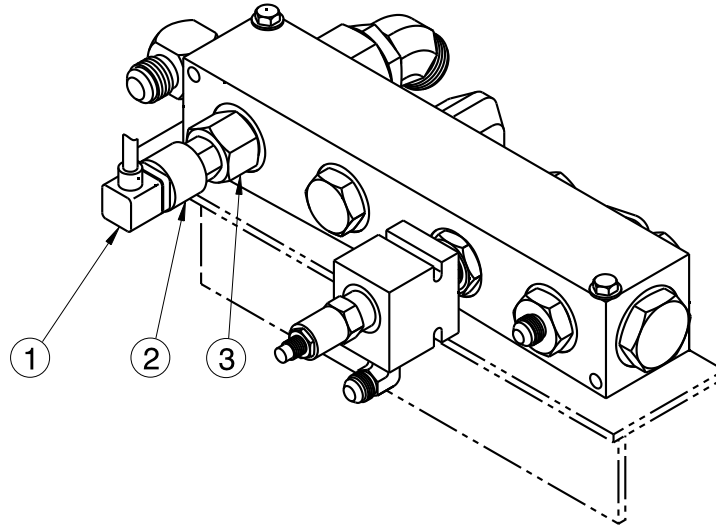

Parts List

Fluid Type: Aviation Phosphate Ester, Type IV

Item	Part Number	Description	Qty
1	EC-1778	DIN CONNECTOR CABLE	1
2	EC-1782-02	TEMPERATURE SWITCH	1
3	N-2463-16-S-E	REDUCER FITTING	1

9.16 REPLACEMENT LABELS PARTS LISTS

9.16.1 Base Unit

Part Number	Description	Qty
V-1001	"MADE IN USA"	1
V-1033-01	"TRONAIR"	1
V-1050	ISO ELECTRICAL SHOCK SYMBOL	2
V-1365	"SYSTEM PRESSURE"	1
V-1366	"HPU BY-PASS VALVE"	1
V-1882	CONTROL PANEL LIGHTS	1
V-1884	"FLOWMETER"	1
V-1893	"SAMPLE VALVE"	1
V-1894	"PRESSURE"	1
V-1895	"RETURN"	1
V-1896	"MAXIMUM OIL LEVEL"	1
V-1897	"MINIMUM OIL LEVEL"	1
V-1900	"WARNING KEEP 5 FT CLEAR..."	2
V-1901	HYDRAULIC SCHEMATIC	1
V-1902	ELECTRICAL SCHEMATIC	1
V-1914	RESERVOIR SELECTOR VALVE	1
V-1918	"PE"	1
V-1919	"OPERATING INSTRUCTIONS..."	1
V-2246	LABEL, PUMP CONTROLS	1

9.16.2 Fluid

Fluid Type: Aviation Phosphate Ester, Type IV

Part Number	Description	Qty
V-1977	"PHOSPHATE ESTER FLUIDS ONLY"	2

9.16.3 Filter Element Kit

Fluid Type: Aviation Phosphate Ester, Type IV

Part Number	Description	Qty
V-1905	"REPLACEMENT FILTER ELEMENT K-3494"	1
V-1903	"REPLACEMENT FILTER ELEMENT K-3428"	1
V-1916	"REPLACEMENT DESICCANT FILTER ELEMENT HC-1763"	1

9.16.4 Split System

Part Number	Description	Qty
V-2004	"SYSTEM 1 PRESSURE"	1
V-2005	"SYSTEM 2 PRESSURE"	1
V-2006	"SYSTEM 1 RETURN"	1
V-2007	"SYSTEM 2 RETURN"	1

9.16.5 Pyrometer

Part Number	Description	Qty
V-1886	"PYROMETER"	1

9.16.6 Hand Pump (Option M)

Part Number	Description	Qty
V-1887	"HAND PUMP PRESSURE"	1
V-1915	"HAND PUMP"	1
V-1989	"REPLACEMENT FILTER ELEMENT K-3752"	1

9.16.7 Calibration Port (Option Q)

Part Number	Description	Qty
V-1470	"CAUTION . . ."	1
V-1888	"SHUT-OFF/CALIBRATION PORT"	1

10.0 PROVISION OF SPARES

10.1 SOURCE OF SPARE PARTS

Spare parts may be obtained from the manufacturer:

TRONAIR, Inc. Telephone: (419) 866-6301 or 800-426-6301
 1 Air Cargo Pkwy East Fax: (419) 867-0634
 Swanton, Ohio 43558 USA E-mail: sales@tronair.com
 Website: www.tronair.com



For Spare Parts, Operations & Service Manuals or Service Needs:
 Scan the QR code or visit Tronair.com/aftermarket

10.2 RECOMMENDED SPARE PARTS LISTS

It is recommended that the following spare parts be kept on hand and available for immediate use during maintenance.

10.2.1 Spare Electrical Parts

Part Number	Description	Qty
Refer to Section 9.10 Electrical Components	FUSE, TRANSFORMER PRIMARY	2
EC-1542-04	FUSE, TRANSFORMER SECONDARY	1
Refer to Section 9.10 Electrical Components	FUSE, HEAT EXCHANGER	3
EC-1419-09	FUSE, PHASE MONITOR (Optional)	3

10.2.2 Spare Parts

Fluid Type: Aviation Phosphate Ester, Type IV

Part Number	Description	Qty
HC-1763	DESICCANT FILTER ELEMENT	1
TBD	KIT, GASKETS AND O-RINGS FOR MAIN PUMP	1
K-1417	KIT, PRESSURE FILTER ELEMENT	1
K-3428	KIT, RETURN FILTER ELEMENT	1
TBD	KIT, SHAFT SEAL AND RETAINER FOR MAIN PUMP	1
K-3752	KIT, HAND PUMP FILTER ELEMENT (Optional)	1

11.0 CALIBRATION OF INSTRUMENTATION

All gauges on the Hydraulic Power Unit can be either returned to Tronair for calibration or certified by the end user if proper calibration equipment is available. Gauges returned to Tronair for calibration will be tested with standards traceable to N.I.S.T. (National Institute of Standards and Technology). Tronair recommends calibration of instrumentation at yearly intervals, but actual calibration dates may be based upon frequency of use and the end users quality system. For information on returning gauges for calibration, Reference **12.1 – Source of Calibration**.

11.1 SOURCE OF CALIBRATION

TRONAIR , Inc. 1 Air Cargo Pkwy East Swanton, Ohio 43558 USA	Telephone: (419) 866-6301 or 800-426-6301 Fax: (419) 867-0634 E-mail: sales@tronair.com Website: www.tronair.com
---	---

11.2 ANALOG PRESSURE GAUGE – System Pressure

11.2.1 Self Calibration

An accurate pressure calibration gauge is required for calibration of the System Pressure gauge. There are two methods available. Method A can be used if the HPU is equipped with a calibration port (*Option Q*). Method B must be used if the HPU is **not** equipped with a calibration port. Follow the necessary steps below.

NOTE: Method A can only test the gauge up to the rated operating pressure of the HPU (3,000 psi).

Method A: Shut off HPU and disconnect from aircraft. Close the calibration port **Shut-off Valve** on the instrument panel of the HPU. Attach the “Master” calibration gauge to the **Calibration Port** on the instrument panel.

Set up the HPU as follows:

Reservoir Selector Valve Set to HPU Reservoir
Bypass Valve..... Open
Pressure Ball Valves (at rear of unit)..... Closed
Return Ball Valves (at rear of unit) Closed

Start the HPU. Open the calibration port Shut-off Valve. Close the Bypass valve to build system pressure. Record gauge values at the designated increments.

Open the Bypass valve.

Shut off the HPU and close the calibration port Shut-off Valve before disconnecting the “Master” calibration gauge.

Method B: Shut off the HPU and disconnect it from the power source. Remove the **Hydraulic Panel** from the front instrument panel (four screws). Disconnect the hose from the System Pressure gauge (remove gauge from panel if necessary). Attach calibration test equipment to the gauge and record gauge values at the designated increments.

SYSTEM PRESSURE GAUGE (HC-2144)

Applied Pressure (System Pressure Gauge) (psig)	Minimum Acceptable (psig)	Maximum Acceptable (psig)	Gauge Movement (Direction)	Indicated Pressure (Calibration Gauge) (psig)
1000	910	1090	Increasing	
2000	1910	2090	Increasing	
3000	2910	3090	Increasing	
4000	3910	4090	Increasing	
5000	4910	5090	Increasing	
6000	5910	6090	Increasing	
5000	4910	5090	Decreasing	
4000	3910	4090	Decreasing	
3000	2910	3090	Decreasing	
2000	1910	2090	Decreasing	
1000	910	1090	Decreasing	

Allowable operating tolerance: +/- 1.5% of full scale (90 psig) at room temperature (70° F).

11.3 ANALOG PRESSURE GAUGE (Hand Pump Pressure- *Option M Only*)

11.3.1 Self Calibration

An accurate pressure calibration gauge is required for calibration of the Hand Pump Pressure gauge. Follow the necessary steps below.

1. Shut off the HPU and disconnect it from the power source.
2. Remove the **Hydraulic Panel** from the front instrument panel (four screws).
3. Disconnect the hose from the Hand Pump Pressure gauge (remove gauge from panel if necessary).
4. Attach calibration test equipment to the gauge and record gauge values at the designated increments.

HAND PUMP PRESSURE GAUGE (HC-2146)

Applied Pressure (Hand Pump Pressure Gauge) (psig)	Minimum Acceptable (psig)	Maximum Acceptable (psig)	Gauge Movement (Direction)	Indicated Pressure (Calibration Gauge) (psig)
1000	700	1300	Increasing	
2000	1700	2300	Increasing	
5000	4800	5200	Increasing	
8000	7700	8300	Increasing	
10,000	9700	10,300	Increasing	
8000	5940	8300	Decreasing	
5000	4800	5200	Decreasing	
2000	1700	2300	Decreasing	
1000	700	1300	Decreasing	
Allowable operating tolerance: +/- 3% of full scale (300 psig) at room temperature (70° F). +/- 2% of full scale for middle third of scale (200 psig) at room temperature (70° F).				

11.4 ANALOG TEMPERATURE GAUGE (Pyrometer)

11.4.1 Self Calibration

An accurate temperature calibration gauge is required for calibration of the Pyrometer. The pyrometer bulb is located in the return manifold (rear of unit) and can be accessed by removal of the HPU top panel. See Section **9.13.7 – Pyrometer** for location. Follow the necessary steps below.

1. Remove the pyrometer bulb from the return manifold by removing the slotted brass nut that retains the bulb in the well.
2. Connect the temperature calibration gauge to the bulb of the pyrometer.

The Temperature Value Must Be:

Pyrometer Temperature Display (° F)	Minimum Acceptable (° F)	Maximum Acceptable (° F)	Temperature Calibration gauge (° F)
160 (159-161)	139	141	

12.0 IN SERVICE SUPPORT

Contact Tronair, Inc. for technical services and information. See Section **1.3 – Manufacturer**.

13.0 GUARANTEES/LIMITATION OF LIABILITY

Tronair products are warranted to be free of manufacturing or material defects for a period of one year after shipment to the original customer. This is solely limited to the repair or replacement of defective components. This warranty does not cover the following items:

- a) Parts required for normal maintenance
- b) Parts covered by a component manufacturers warranty
- c) Replacement parts have a 90-day warranty from date of shipment

If you have a problem that may require service, contact Tronair immediately. Do not attempt to repair or disassemble a product without first contacting Tronair, any action may affect warranty coverage. When you contact Tronair be prepared to provide the following information:

- a) Product Model Number
- b) Product Serial Number
- c) Description of the problem

If warranty coverage is approved, either replacement parts will be sent or the product will have to be returned to Tronair for repairs. If the product is to be returned, a Return Material Authorization (RMA) number will be issued for reference purposes on any shipping documents. Failure to obtain a RMA in advance of returning an item will result in a service fee. A decision on the extent of warranty coverage on returned products is reserved pending inspection at Tronair. Any shipments to Tronair must be shipped freight prepaid. Freight costs on shipments to customers will be paid by Tronair on any warranty claims only. Any unauthorized modification of the Tronair products or use of the Tronair products in violation of cautions and warnings in any manual (including updates) or safety bulletins published or delivered by Tronair will immediately void any warranty, express or implied.

The obligations of Tronair expressly stated herein are in lieu of all other warranties or conditions expressed or implied. **Any unauthorized modification of the Tronair products or use of the Tronair products in violations of cautions and warnings in any manual (including updates) or safety bulletins published or delivered by Tronair will immediately void any warranty, express or implied and Tronair disclaims any and all liability for injury (WITHOUT LIMITATION and including DEATH), loss or damage arising from or relating to such misuse.**

14.0 APPENDICES

APPENDIX I	Hydraulic Schematic (INS-1602)
APPENDIX II	Electrical Schematic (INS-1608 and INS-2016)
APPENDIX III	Wiring Diagram (INS-1746 and INS-2144)
APPENDIX IV	Declaration of Conformity
APPENDIX V	Lincoln Motor Manual
APPENDIX VI	Oilgear Type PVWJ Pump Manuals
APPENDIX VII	Safety Data Sheet (SDS) pertaining to Hydraulic Fluid
APPENDIX VIII	Instrument Certification Notice



APPENDIX I

Hydraulic Schematic (INS-1602)

THIS DRAWING IS THE PROPERTY OF TRONAIR, INC. IT IS FURNISHED TO YOU FOR CONFIDENTIAL INFORMATION PURPOSES ONLY AND IS NOT TO BE DISCLOSED TO ANYONE ELSE OR REPRODUCED OR USED FOR MANUFACTURING PURPOSES WITHOUT THE EXPRESS WRITTEN PERMISSION OF TRONAIR, INC.

LET	REVISION	ECN	DWN	CHK	DATE
-	ORIGINAL RELEASE	10866	-	-	04-25-00
A	SEE ECN	11223	MAH	-	11-18-00
B	REDRAWN/REVISED	11575	WCG	MAB	07-06-01
C	ADDED OPTION T	12849	WCG	PEH	01-31-03
D	ADDED FILTER CLOGGING SWITCH	12912	WCG	PEH	02-17-03

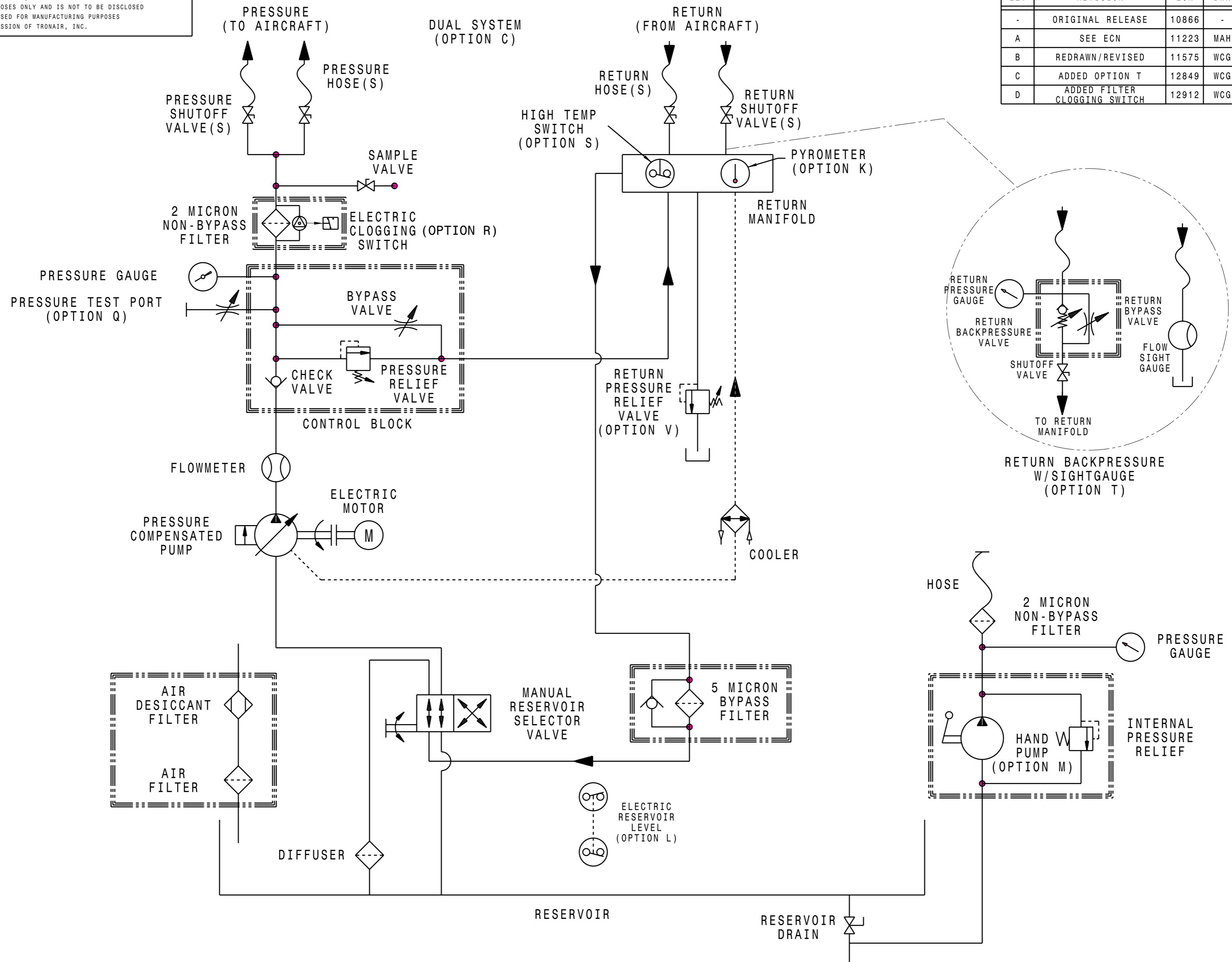

MAKE FROM:	N / A
MATERIAL:	N / A
FINISH:	N / A
REFERENCE:	N / A
SCALE:	FULL
TYPE:	N / A
SIZE:	C
DO NOT SCALE DRAWING	

BREAK ALL SHARP EDGES AND CORNERS
TOLERANCES UNLESS OTHERWISE SPECIFIED

DECIMAL	.X	± .100
	.XX	± .030
	.XXX	± .010
FRACTION	X/XX	± 1/16

ANGLES: ± 1/2 DEGREE
< > INDICATES CRITICAL DIMENSIONS
() INDICATES REFERENCE DIMENSIONS

TRONAIR AIRCRAFT GROUND SUPPORT EQUIPMENT

DWN BY	MAB	CKD BY	WJL	DATE	04-25-00
SCHEMATIC, HYDRAULIC					
REV	05	INS-1602	REV	D	



APPENDIX II

**Electrical Schematic
(INS-1608 and INS-2016)**

THIS DRAWING IS THE PROPERTY OF TRONAIR, INC. IT IS FURNISHED TO YOU FOR CONFIDENTIAL INFORMATION PURPOSES ONLY AND IS NOT TO BE DISCLOSED TO ANYONE ELSE OR REPRODUCED OR USED FOR MANUFACTURING PURPOSES WITHOUT THE EXPRESS WRITTEN PERMISSION OF TRONAIR, INC.

LET	REVISION	ECN	DWN	CHK	DATE
C	1. ADDED J1 2. ADDED J2 3. ADDED J3 4. ADDED J4	12912	WCG	PEH	03-06-03
D	REVISED	12979	DEP	PEH	04-03-03
E	REVISED	13159	MAH	PEH	08-29-03

- WIRE COLORS:**
- LT - BLUE
 - RED
 - INTERCONNECTION
 - 3 PHASE
 - BLACK
 - GREEN/YELLOW
 - (XX) - DEVICE TERMINATION
 - - TERMINAL BLOCK CONNECTION
 - 1TB - GROUND TERMINAL BLOCK
 - 2TB - NEUTRAL TERMINAL BLOCK
 - 3TB - CONTROL TERMINAL BLOCK 120VAC
 - OPTIONS JUMPERS
- COMPONENT ABBREVIATION**
- MS - MOTOR STARTER
 - OL - OVERLOAD
 - MTR - MOTOR
 - SW - SWITCH
 - PM - PHASE MONITOR
 - CR - CONTROL RELAY
 - SOL - SOLENOID
 - HR - HOURMETER
 - FU - FUSE
 - TR - TRANSFORMER
 - LT - LIGHT
 - SN - SENSOR
 - PE - POTENTIAL EARTH

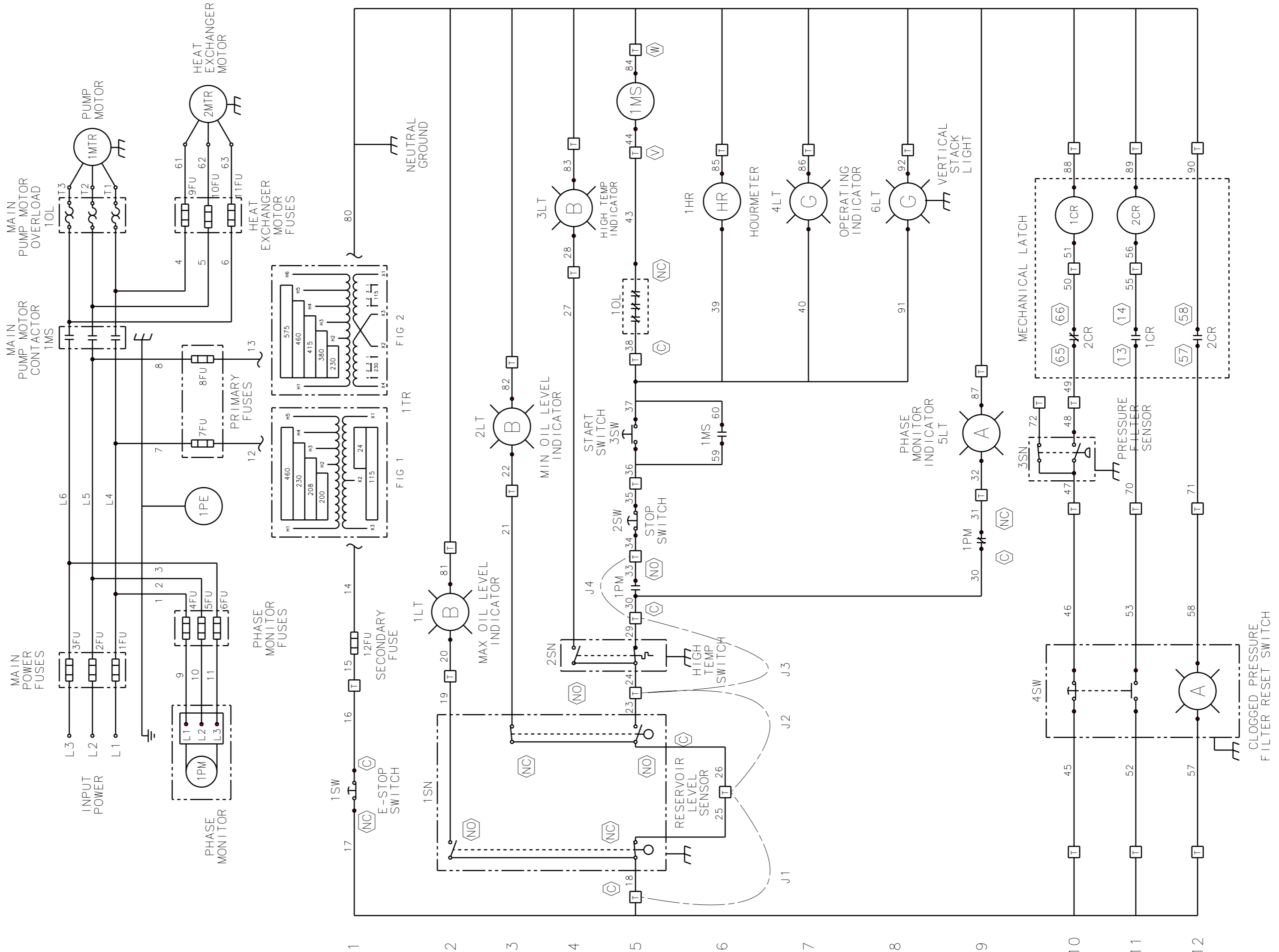

MAKE FROM: N / A	TYPE: N / A
MATERIAL: N / A	FINISH: MILL
REFERENCE: E-546-271 (REV A)	SIZE: C
SCALE: N.S.R.	DO NOT SCALE DRAWING

BREAK ALL SHARP EDGES AND CORNERS
TOLERANCES UNLESS OTHERWISE SPECIFIED

DECIMAL .X ± .100
.XX ± .030
.XXX ± .010

FRACTION X/XX ± 1/16

ANGLES: ± 1/2 DEGREE

< > INDICATES CRITICAL DIMENSIONS
() INDICATES REFERENCE DIMENSIONS

TRONAIR AIRCRAFT GROUND SUPPORT EQUIPMENT

DWN BY MAB CKD BY XXX 05-25-00

SCHEMATIC, HPU ELECTRICAL (CE)

05 INS-1608 REV E

THIS DRAWING IS THE PROPERTY OF TRONAIR, INC. IT IS FURNISHED TO YOU FOR CONFIDENTIAL INFORMATION PURPOSES ONLY AND IS NOT TO BE DISCLOSED TO ANYONE ELSE OR REPRODUCED OR USED FOR MANUFACTURING PURPOSES WITHOUT THE EXPRESS WRITTEN PERMISSION OF TRONAIR, INC.

LET	REVISION	ECN	DWN	CHK	DATE
01	ORIGINAL RELEASE	16922	-	-	06-08-09

COMPONENT ABBREVIATION
 MS - MOTOR STARTER
 OL - OVERLOAD
 MTR - MOTOR
 SW - SWITCH
 PM - PHASE MONITOR
 CR - CONTROL RELAY
 SOL - SOLENOID
 HR - HOURMETER
 FU - FUSE
 TR - TRANSFORMER
 LT - LIGHT
 SN - SENSOR
 ML - MECHANICAL LATCH

WIRE COLORS:
 - LT, BLUE
 - RED
 - BLACK
 - GREEN/YELLOW

☒ - DEVICE TERMINATION
 □ - TERMINAL BLOCK CONNECTION
 1TB - GROUND TERMINAL BLOCK
 2TB - NEUTRAL TERMINAL BLOCK
 3TB - CONTROL TERMINAL BLOCK 120VAC

— OPTIONS JUMPER

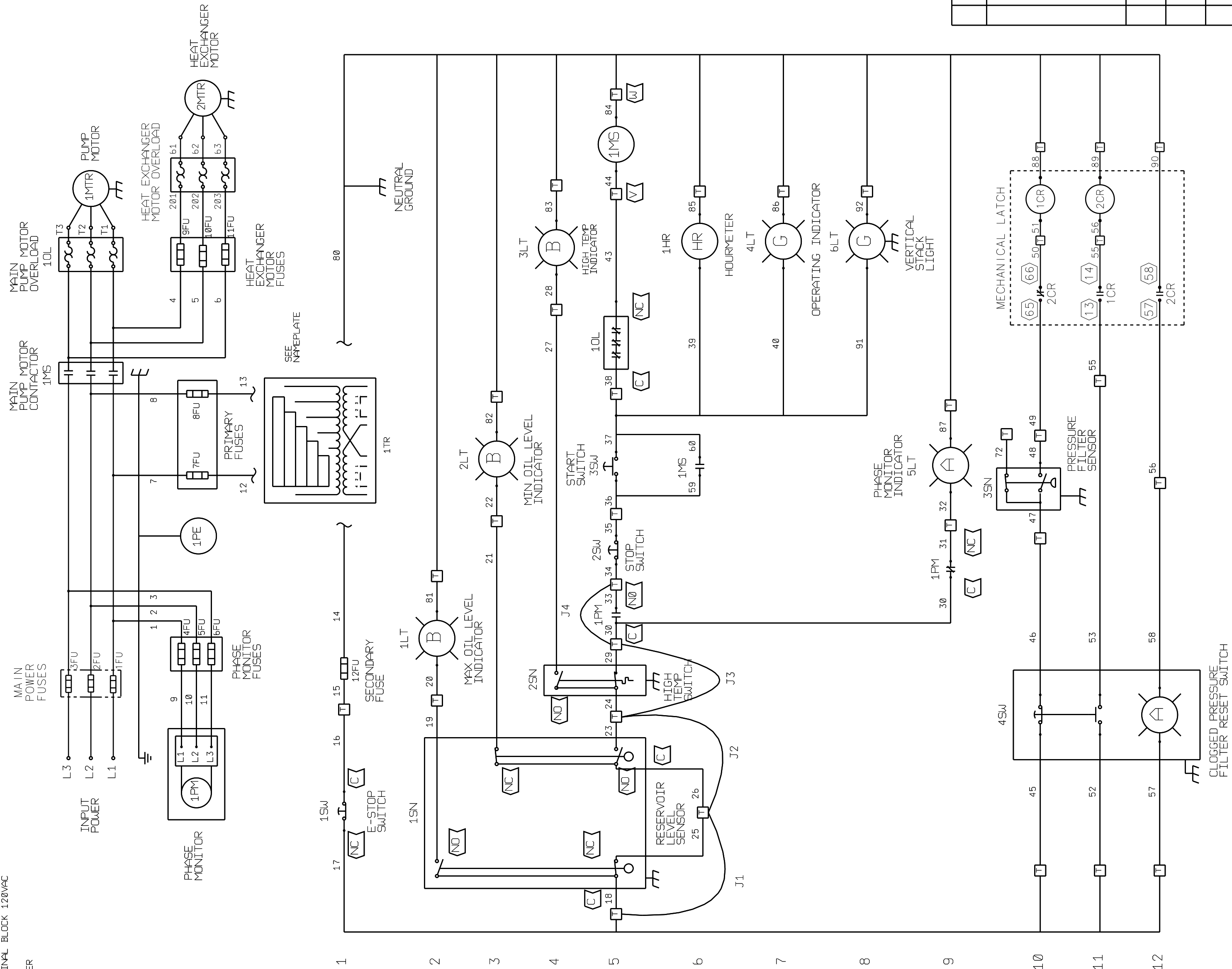

MAKE FROM: N / A	TYPE: N / A
MATERIAL: N / A	FINISH: MILL
REFERENCE: INS-1725	SCALE: N. S. R. DO NOT SCALE DRAWING

BREAK ALL SHARP EDGES AND CORNERS
 TOLERANCES UNLESS OTHERWISE SPECIFIED
 DECIMAL .X ± .100
 .XX ± .030
 .XXX ± .010
 FRACTION XXX ± 1/16
 ANGLES: ± 1/2 DEGREE
 () INDICATES CRITICAL DIMENSIONS
 () INDICATES REFERENCE DIMENSIONS

TRONAIR AIRCRAFT GROUND SUPPORT EQUIPMENT

DWN BY JMB CRD BY PEH 06-08-09

SCHEMATIC, HPU ELECTRICAL (K-4321)

05 INS-2016 REV 01



APPENDIX III

Wiring Diagram (INS-1746 and INS-2144)

THIS DRAWING IS THE PROPERTY OF TRONAIR, INC. IT IS FURNISHED TO YOU FOR CONFIDENTIAL INFORMATION PURPOSES ONLY AND IS NOT TO BE REPRODUCED OR TRANSMITTED IN ANY FORM OR BY ANY MEANS, ELECTRONIC OR MECHANICAL, WITHOUT THE EXPRESS WRITTEN PERMISSION OF TRONAIR, INC.

LET	REVISION	ECN	DWN	CHK	DATE
	ORIGINAL RELEASE	13016			04-22-03
A	REVISED 3 PHASE WIRE NUMBER	13325	GAM	WGO	10-01-03
B	ADDED STACK LIGHT OPTION	15879	JMB	PEH	08-09-07

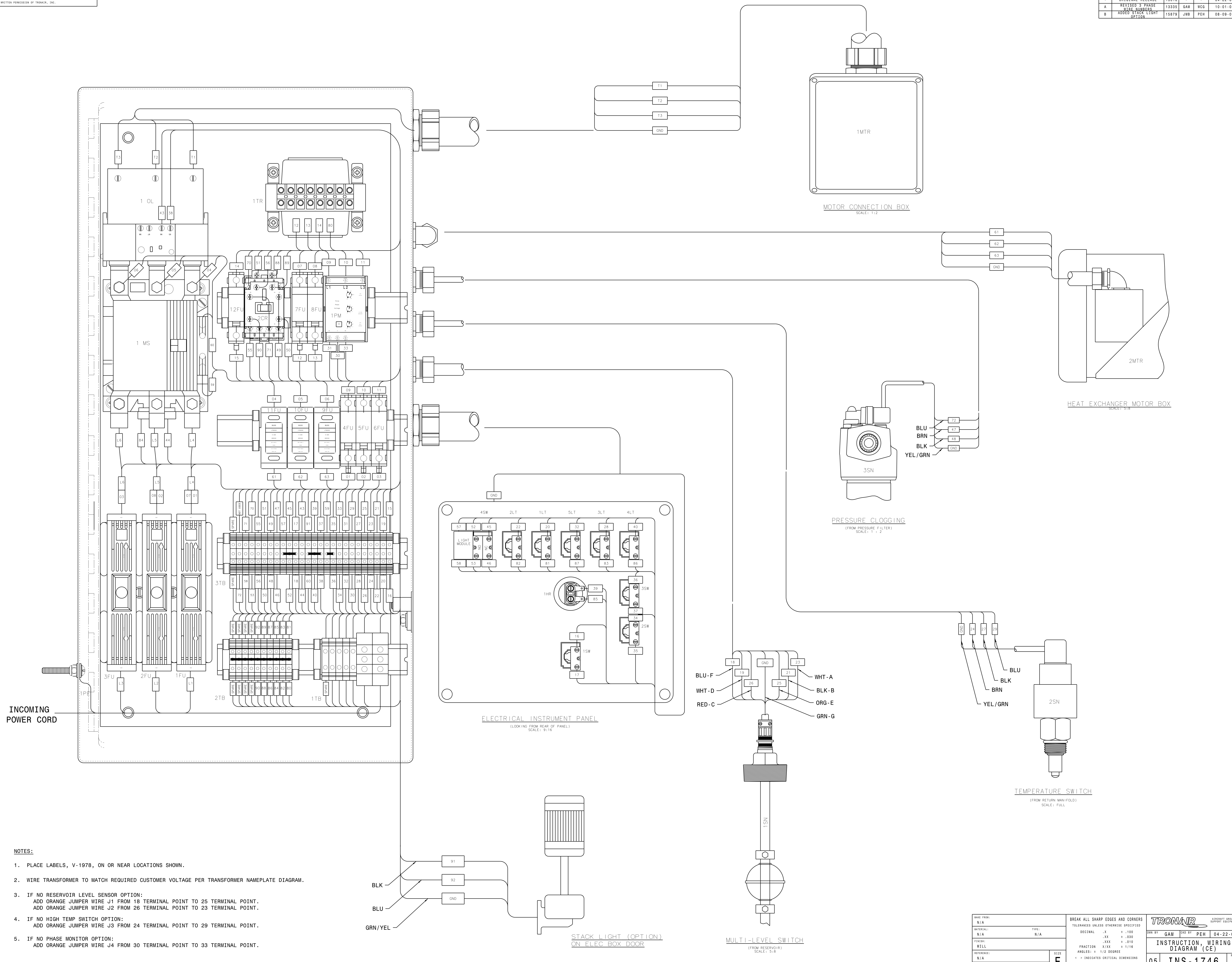

- NOTES:**
- PLACE LABELS, V-1978, ON OR NEAR LOCATIONS SHOWN.
 - WIRE TRANSFORMER TO MATCH REQUIRED CUSTOMER VOLTAGE PER TRANSFORMER NAMEPLATE DIAGRAM.
 - IF NO RESERVOIR LEVEL SENSOR OPTION:
ADD ORANGE JUMPER WIRE J1 FROM 18 TERMINAL POINT TO 25 TERMINAL POINT.
ADD ORANGE JUMPER WIRE J2 FROM 26 TERMINAL POINT TO 23 TERMINAL POINT.
 - IF NO HIGH TEMP SWITCH OPTION:
ADD ORANGE JUMPER WIRE J3 FROM 24 TERMINAL POINT TO 29 TERMINAL POINT.
 - IF NO PHASE MONITOR OPTION:
ADD ORANGE JUMPER WIRE J4 FROM 30 TERMINAL POINT TO 33 TERMINAL POINT.

NAME FROM: N/A	TYPE: N/A	BREAK ALL SHARP EDGES AND CORNERS TOLERANCES UNLESS OTHERWISE SPECIFIED	
MATERIAL: N/A	FINISH: WILL	DECIMAL .X ± .100 .XX ± .020 .XXX ± .010	
REVISIONS: N/A	SIZE: E	FRACTION X/XX ± 1/16 ANGLES: ± 1/2 DEGREE () INDICATES CRITICAL DIMENSIONS () INDICATES REFERENCE DIMENSIONS	
SCALE: 3:4	DO NOT SCALE DRAWING		
DWN BY: GAM		CHK BY: PEH	
INSTRUCTION, WIRING DIAGRAM (CE)			REV: B
05 INS-1746			

THIS DRAWING IS THE PROPERTY OF TRONAIR, INC. IT IS LOANED TO YOU FOR CONFIDENTIAL INFORMATION PURPOSES ONLY AND IS NOT TO BE DISCLOSED TO ANYONE ELSE OR REPRODUCED OR USED FOR MANUFACTURING PURPOSES WITHOUT THE EXPRESS WRITTEN PERMISSION OF TRONAIR, INC.

LET	REVISION	ECN	DWN	CHK	DATE
-	ORIGINAL RELEASE	18824	-	-	05-03-12

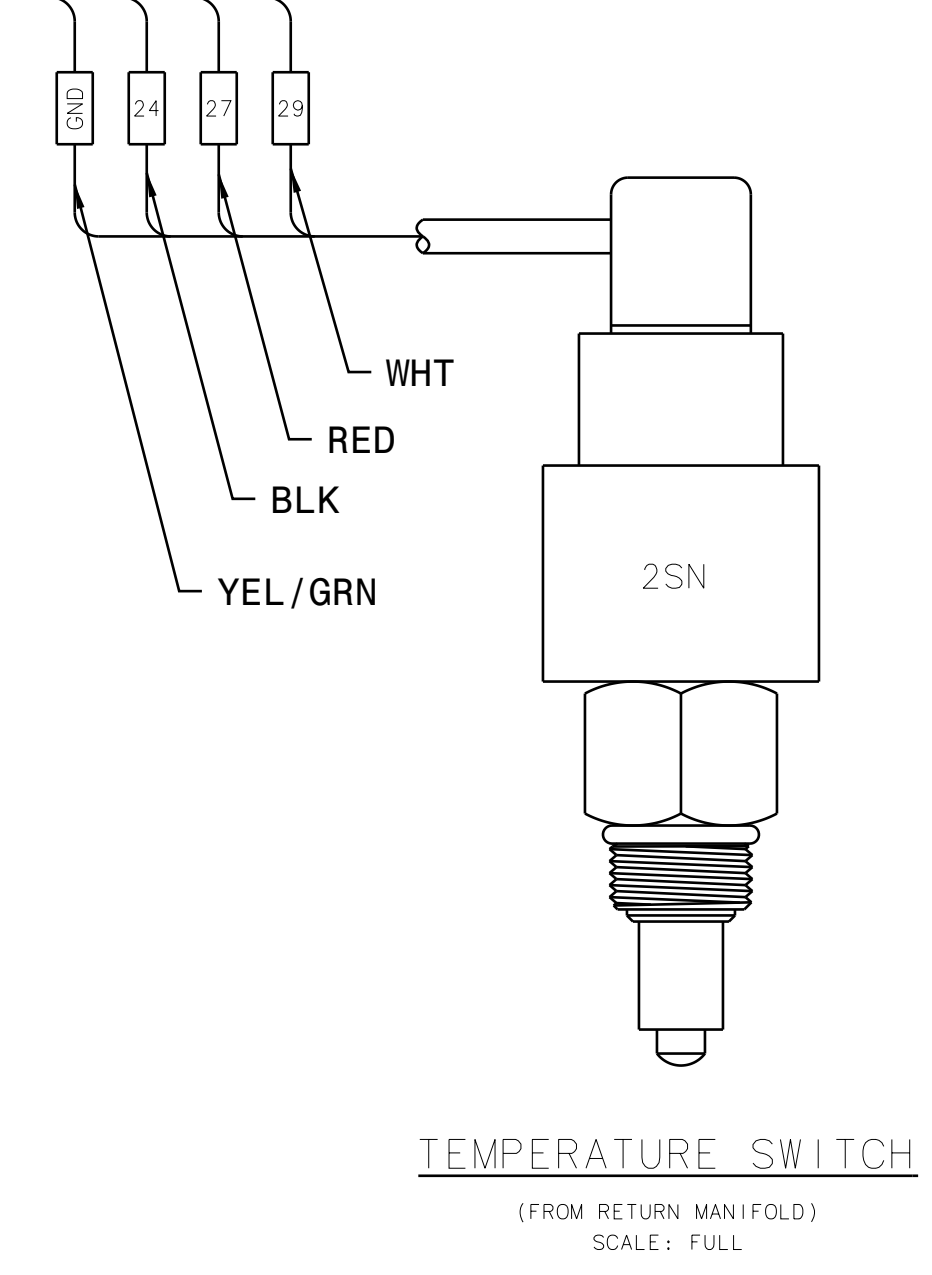
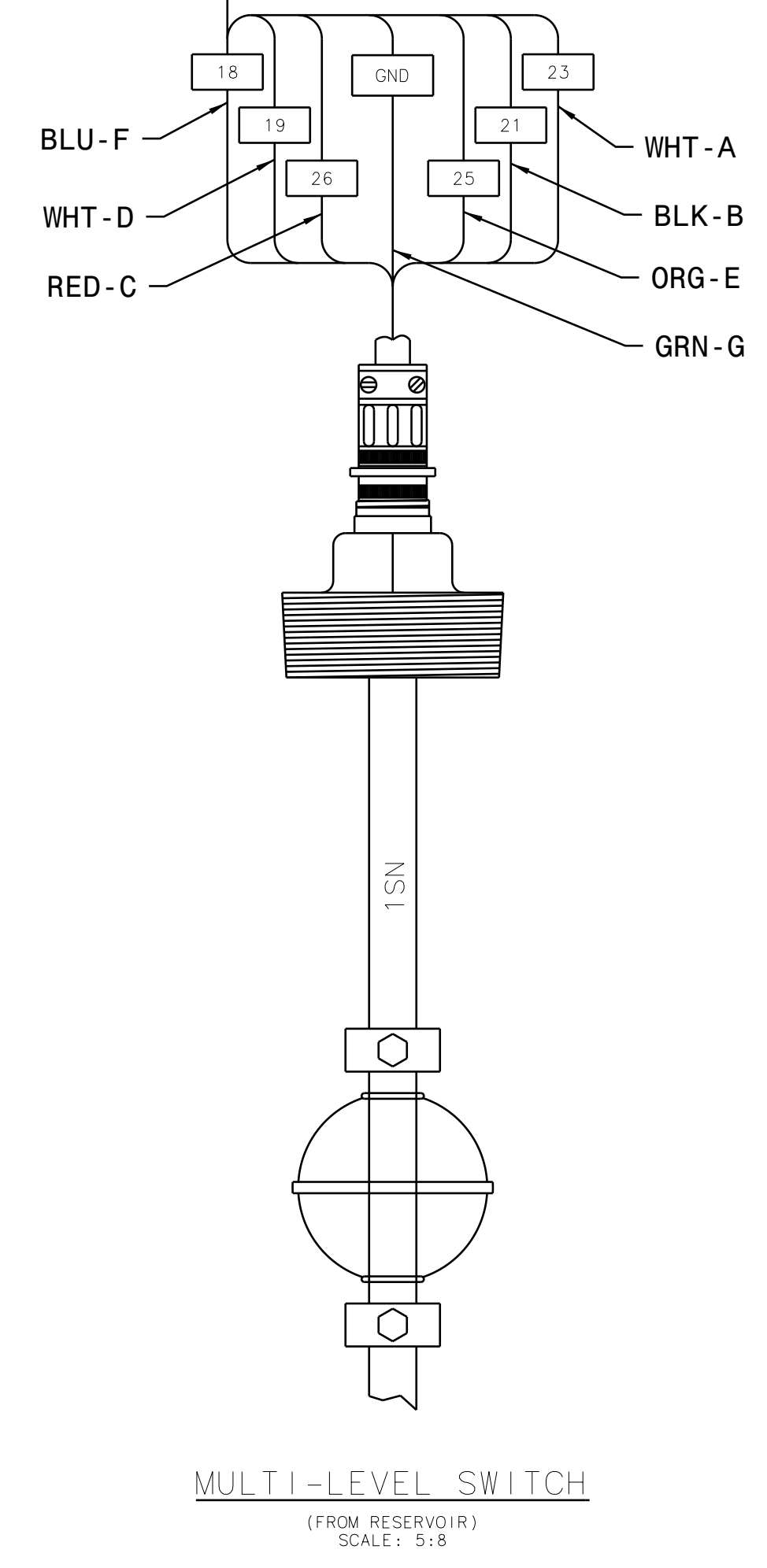
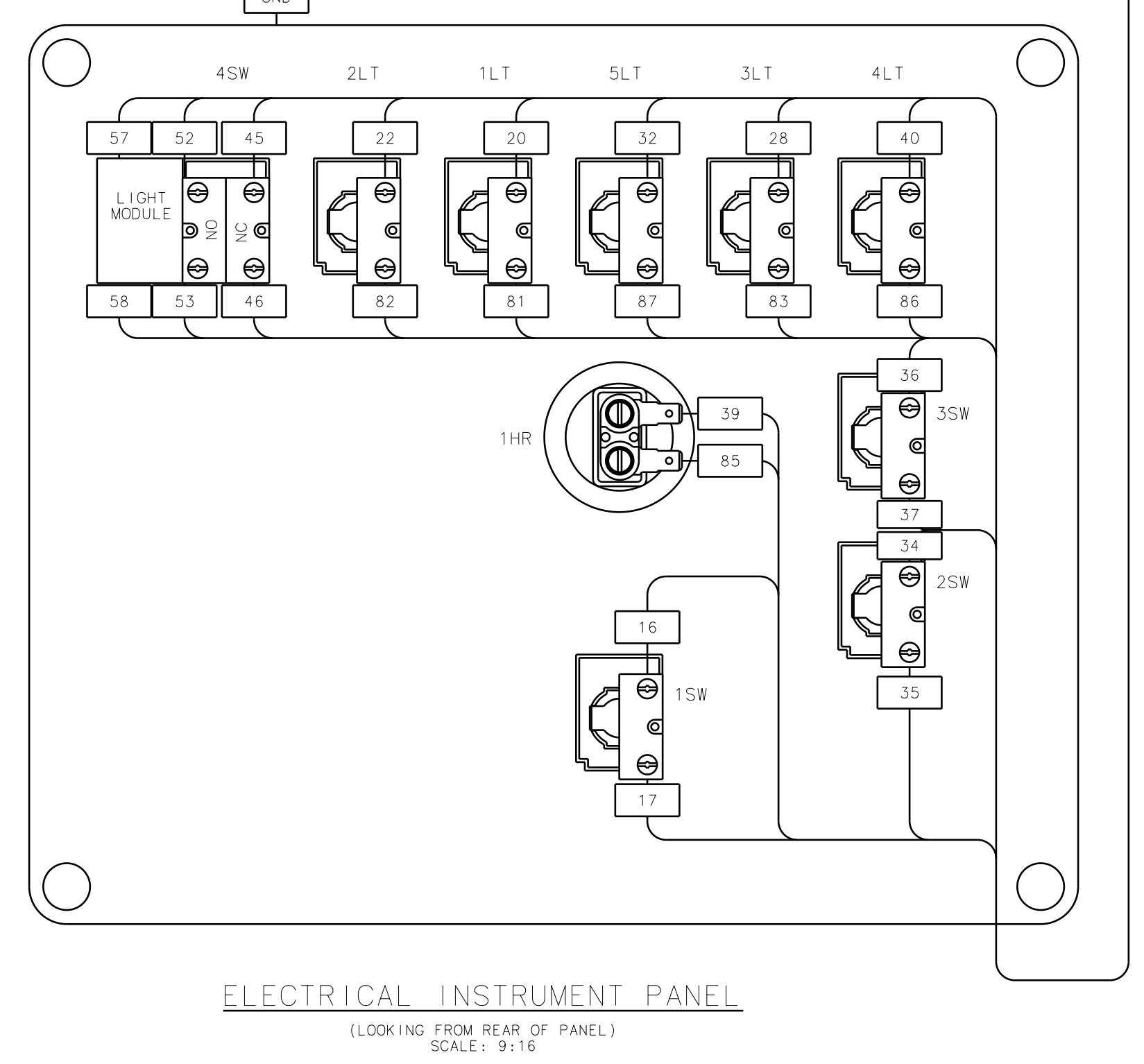
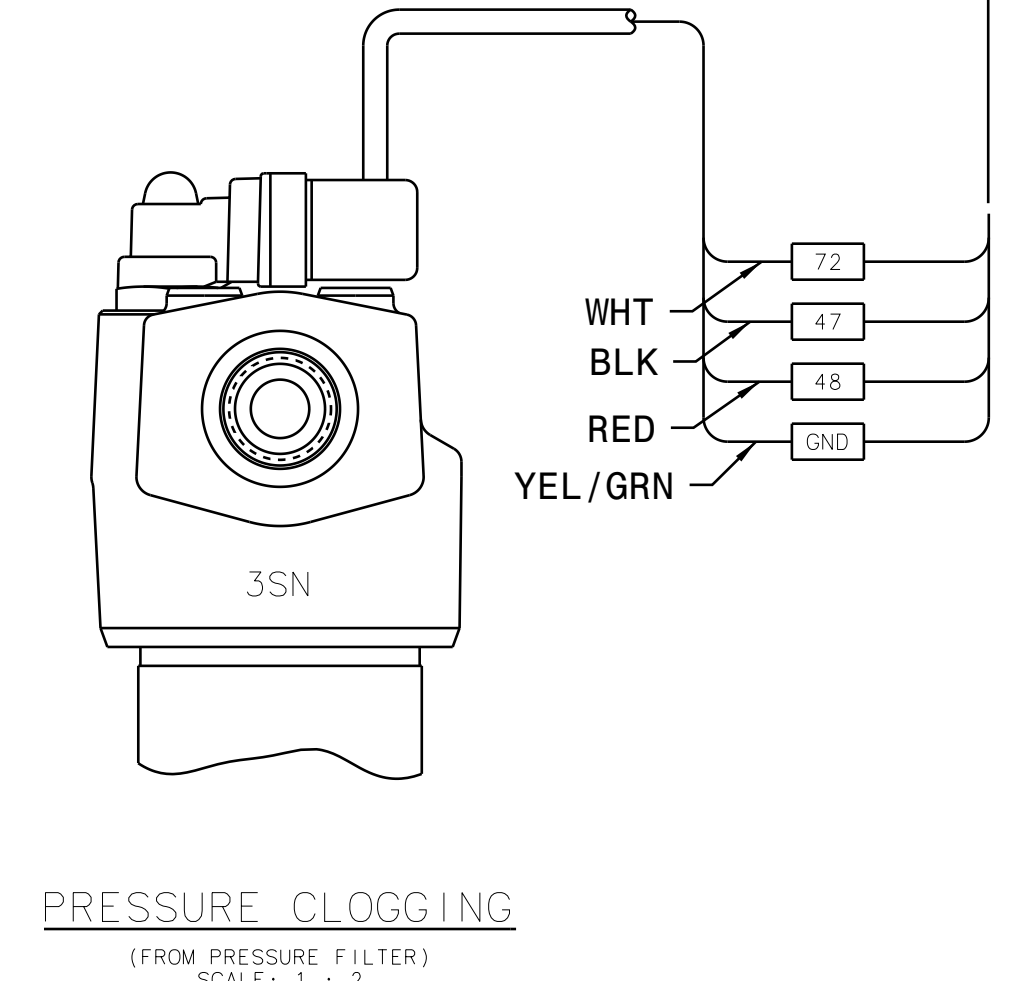
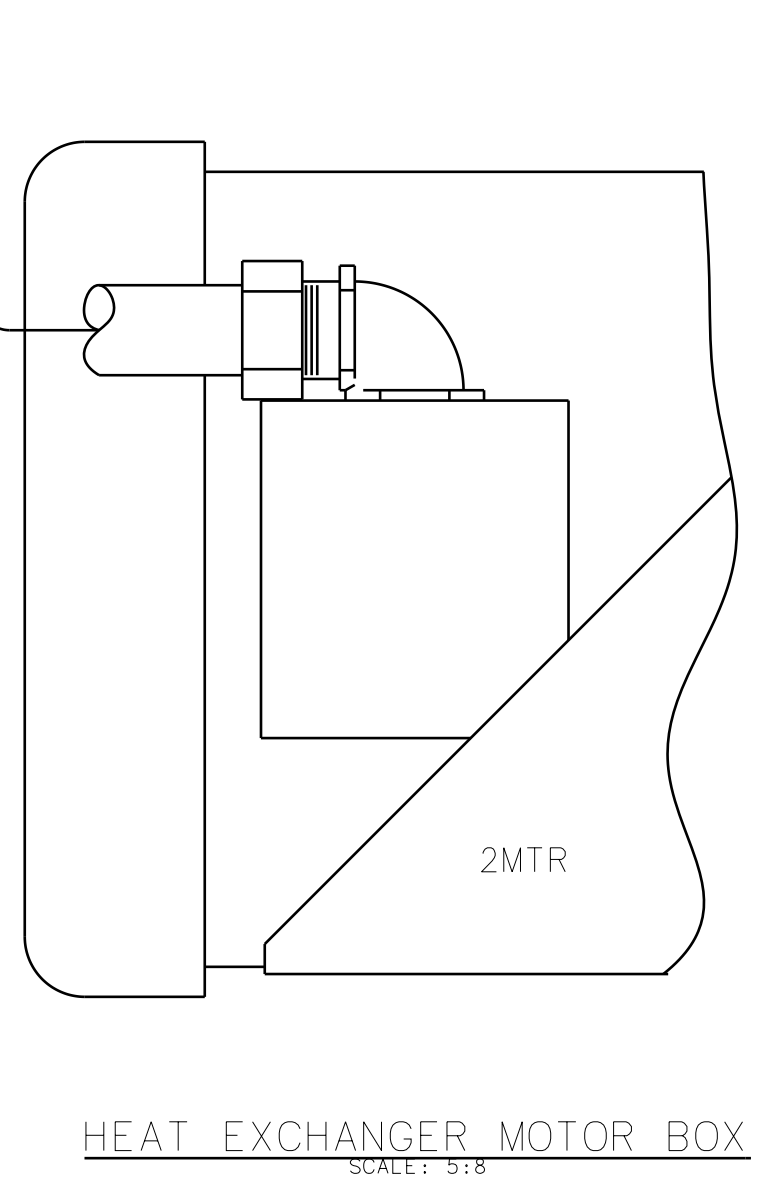
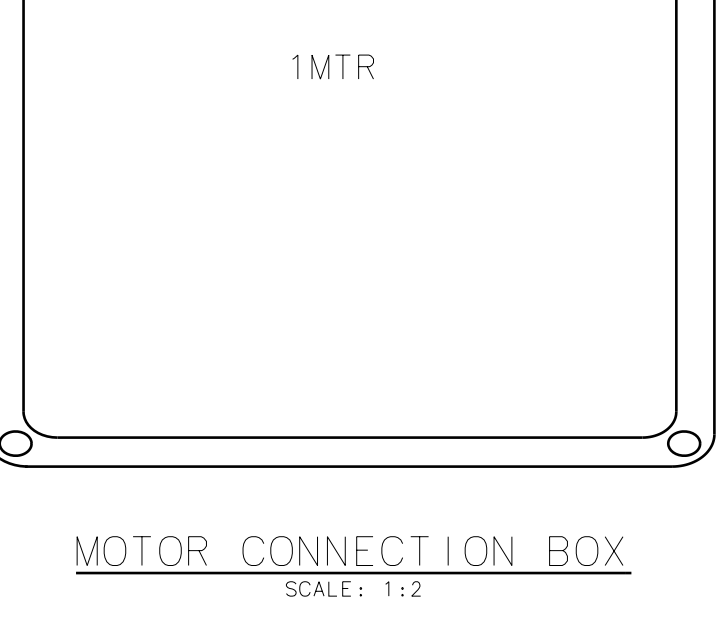
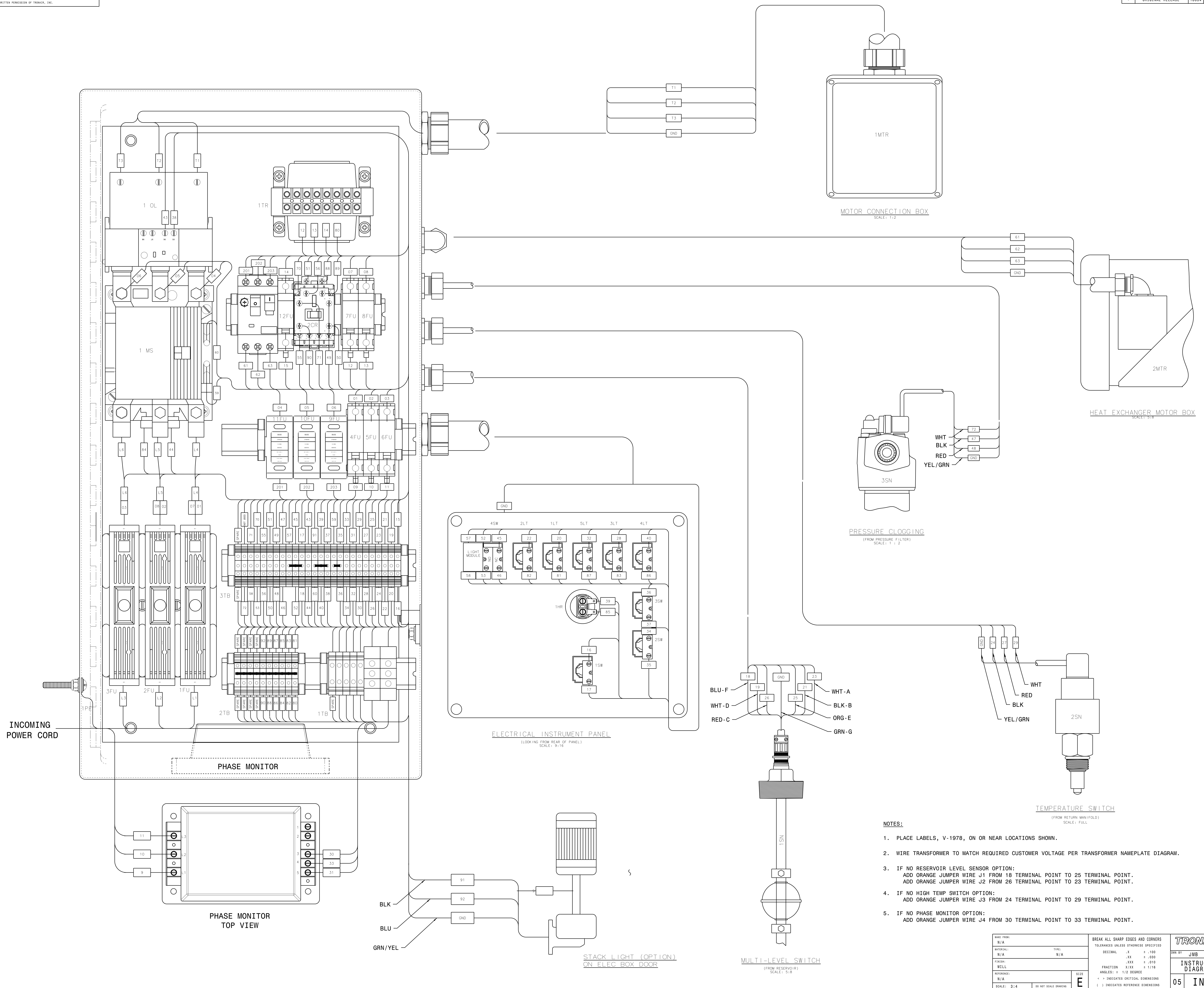

- NOTES:**
- PLACE LABELS, V-1978, ON OR NEAR LOCATIONS SHOWN.
 - WIRE TRANSFORMER TO MATCH REQUIRED CUSTOMER VOLTAGE PER TRANSFORMER NAMEPLATE DIAGRAM.
 - IF NO RESERVOIR LEVEL SENSOR OPTION:
ADD ORANGE JUMPER WIRE J1 FROM 18 TERMINAL POINT TO 25 TERMINAL POINT.
ADD ORANGE JUMPER WIRE J2 FROM 26 TERMINAL POINT TO 23 TERMINAL POINT.
 - IF NO HIGH TEMP SWITCH OPTION:
ADD ORANGE JUMPER WIRE J3 FROM 24 TERMINAL POINT TO 29 TERMINAL POINT.
 - IF NO PHASE MONITOR OPTION:
ADD ORANGE JUMPER WIRE J4 FROM 30 TERMINAL POINT TO 33 TERMINAL POINT.

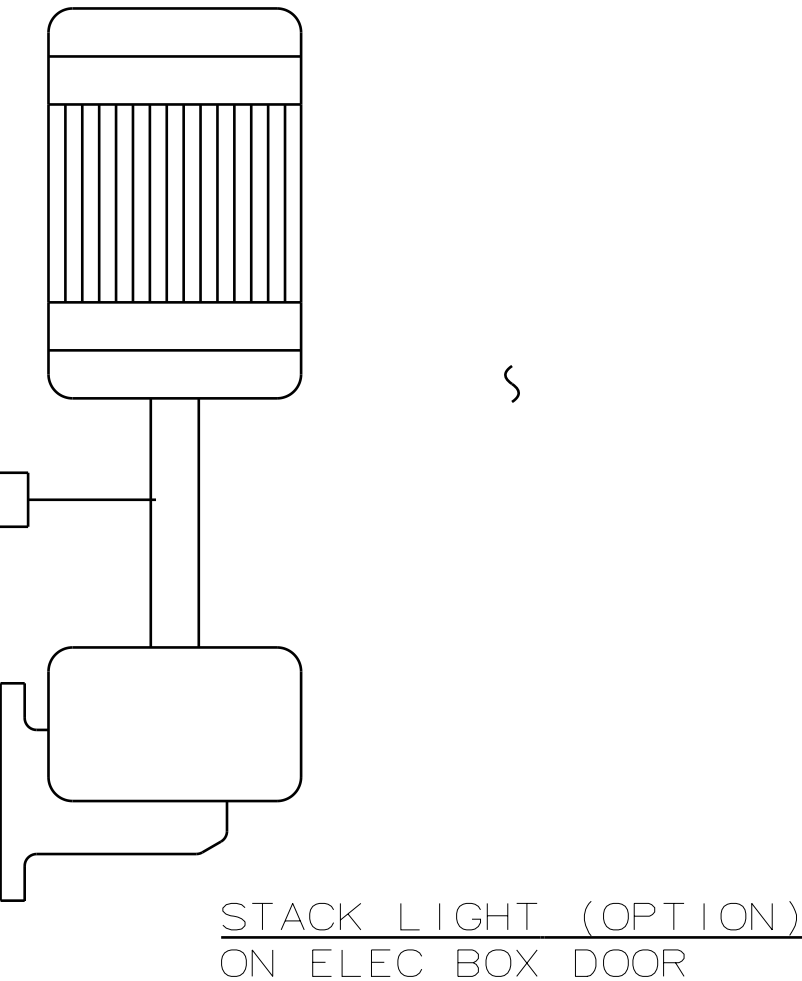
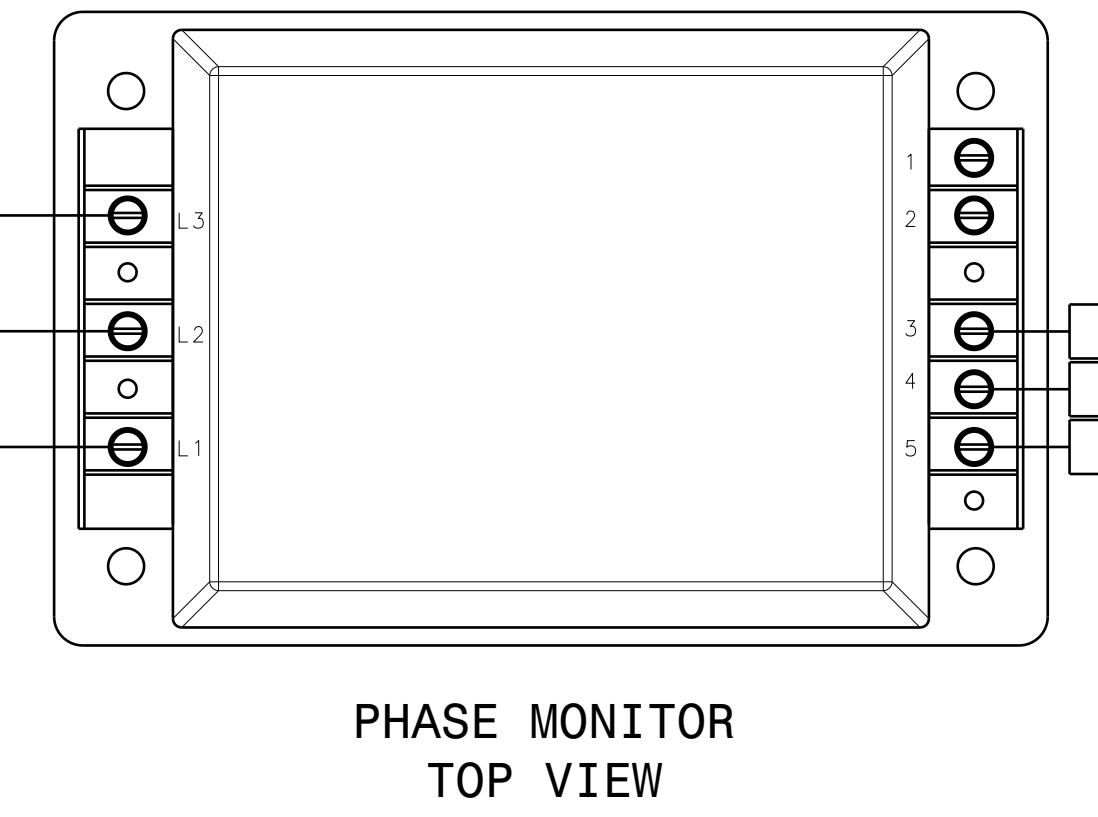

NAME FROM:	N/A	BREAK ALL SHARP EDGES AND CORNERS TOLERANCES UNLESS OTHERWISE SPECIFIED																			
MATERIAL:	N/A	DECIMAL .X .100 .XX .000 .XXX .010																			
FINISH:	MILL	FRACTION X/XX 1/16 ANGLES: ± 1/2 DEGREE < > INDICATES CRITICAL DIMENSIONS () INDICATES REFERENCE DIMENSIONS	<table border="1"> <tr> <td>DWN BY</td> <td>JMB</td> <td>CHK BY</td> <td>PEH</td> <td>DATE</td> <td>05-22-12</td> </tr> <tr> <td colspan="6">INSTRUCTION WIRING DIAGRAM (CE) (CSA)</td> </tr> <tr> <td>REV</td> <td>05</td> <td>INS-2144</td> <td>A</td> <td></td> <td></td> </tr> </table>	DWN BY	JMB	CHK BY	PEH	DATE	05-22-12	INSTRUCTION WIRING DIAGRAM (CE) (CSA)						REV	05	INS-2144	A		
DWN BY	JMB	CHK BY	PEH	DATE	05-22-12																
INSTRUCTION WIRING DIAGRAM (CE) (CSA)																					
REV	05	INS-2144	A																		



APPENDIX IV

Declaration of Conformity



Declaration of Conformity

The design, development and manufacture is in accordance with European Community guidelines

Mobile Hydraulic Power Unit (Electric Motor Driven)

Relevant draft complied with by the machinery:
prEN 1915-1:1995

Relevant standards complied with by the machinery:
prEN 982:1996
prEN 60204-1:1997
HFPA/JIC T2.24.1-1990
ISO 4021:1997
ARP 1247B
NFPA 70/NEC 1999

Identification of person empowered to sign on behalf of the Manufacturer:

A handwritten signature in cursive script that reads "Patrick Finch". The signature is written in black ink and is positioned above a horizontal line.

Quality Assurance Representative



APPENDIX V

Lincoln Motor Manual

Carefully read and fully understand this Owner's Manual prior to installation, operation and maintenance of your motor.

1. SAFETY DEPENDS ON YOU

Lincoln motors are designed and manufactured with safety in mind. However, your overall safety can be increased by properly installing, operating and maintaining the motor. Read and observe all instructions, warnings and specific safety precautions included in this manual and **THINK BEFORE YOU ACT!**

2. RECEIVING AND INSPECTION

Check packing list and inspect motor to make certain no damage has occurred in shipment. Claims for any damage done in shipment must be made by the purchaser against the transportation company.

Turn the motor shaft by hand to be certain that it rotates freely. Be careful not to cut yourself on the shaft keyway; it is razor sharp!

Check the nameplate for conformance with power supply and control equipment requirements.

3. HANDLING

 WARNING	
	FALLING EQUIPMENT can injure.
	<ul style="list-style-type: none"> ● Lift only with equipment of adequate lifting capacity. ● If so equipped, use lift ring(s) on the motor to lift ONLY the motor and accessories mounted by Lincoln.

In case of assemblies on a common base, the motor lift ring(s) **CANNOT** be used to lift the assembly and base but, rather, the assembly should be lifted by a sling around the base or by other lifting means provided on the base. In all cases, care should be taken to assure lifting in the direction intended in the design of the lifting means. Likewise, precautions should be taken to prevent hazardous overloads due to deceleration, acceleration or shock forces.

4. STORAGE

Motor stock areas should be clean, dry, vibration free and have a relatively constant ambient temperature. For added bearing protection while the motor is in storage, turn the motor shaft every six months.

A motor stored on equipment and component equipment prior to installation should be kept dry and protected from the weather. If the equipment is exposed to the atmosphere, cover the motor with a waterproof cover. Motors should be stored in the horizontal position with drains operable and positioned in the lowest point. **CAUTION:** Do not completely surround the motor with the protective covering. The bottom area should be open at all times.

Windings should be checked with a megohm-meter (Megger) at the time equipment is put in storage. Upon removal from storage, the resistance reading must not have dropped more than 50% from the initial reading. Any drop below this point necessitates electrical or mechanical drying. Note the sensitivity of properly connected megohm-meters can deliver erroneous values. Be sure to carefully follow the megohm-meter's operating instructions when making measurements.

All external motor parts subject to corrosion, such as the shaft and other machined surfaces, must be protected by applying a corrosion-resistant coating.

5. INSTALLATION

For maximum motor life, locate the motor in a clean, dry, well ventilated place easily accessible for inspecting, cleaning and lubricating. The temperature of the surrounding air should not exceed 104°F (40°C) except for motors with nameplates indicating a higher allowable maximum ambient temperature.

 WARNING	
	MOVING PARTS can injure.
	<ul style="list-style-type: none"> ● BEFORE starting motor, be sure shaft key is captive. ● Consider application and provide guarding to protect personnel.

5.1 INSTALLATION – MECHANICAL

Base

Mount the motor on a firm foundation or base sufficiently rigid to prevent excessive vibration. On foot-mounted motors, use appropriately sized bolts through all four mounting holes. For frames which have six or eight mounting holes, use the two closest the drive shaft and two on the end opposite the drive shaft (one on each side of the frame). If necessary, properly shim the motor to prevent undue stress on the motor frame and to precision align the unit.

Position

Standard motors may be mounted in any position. The radial and thrust load capacity of the motor's bearing system provides for this feature.

Drains

All motors have drain holes located in the end brackets. As standard, drains are in place for the horizontal with feet down mounting position. Other positions may require either rotation of the end brackets or drilling additional holes to attain proper drainage. Be sure existing drain or vent holes do not permit contaminant entry when motor is mounted in the other positions.

Additional drain holes exist near the bearing cartridge in both end brackets of 284T thru 449T steel frame motors. The drain holes are closed with a plastic plug. When the motor is vertically mounted, the plug located in the lower end bracket must be removed. To access the plug on blower end, simply remove the shroud; on some models, it is also necessary to take off the blower.

Drive – Power Transmission

The pulley, sprocket, or gear used in the drive should be located on the shaft as close to the shaft shoulder as possible. Do not drive the unit on the shaft as this will damage the bearings. Coat the shaft lightly with heavy oil before installing pulley.

Belt Drive: Align the pulleys so that the belt(s) will run true. Consult the belt manufacturer's catalog for recommended tension. Properly tension the belt; excessive tension will cause premature bearing failure. If possible, the lower side of the belt should be the driving side. On multiple belt installations be sure all belts are matched for length.

Chain Drive: Mount the sprocket on the shaft as close to the shaft shoulder as possible. Align the sprockets so that the chain will run true. Avoid excessive chain tension.

Gear Drive and Direct Connection: Accurate alignment is essential. Secure the motor and driven unit rigidly to the base. Shims may be needed to achieve proper alignment.

Excessive motor vibration may result if the full length of the motor shaft key is not completely engaged by the coupling or sheave. For these situations, adjustment of the key length is required.

5.2 INSTALLATION – ELECTRICAL

⚠ WARNING

ELECTRIC SHOCK can kill.

- Disconnect input power supply before installing or servicing motor.
- Motor lead connections can short and cause damage or injury if not well secured and insulated.

- Use washers, lock washers and the largest bolt size which will pass through the motor lead terminals in making connections.
- Insulate the connection, equal to or better than the insulation on the supply conductors.
- Properly ground the motor — see GROUNDING.

Check power supply to make certain that voltage, frequency and current carrying capacity are in accordance with the motor nameplate.

Proper branch circuit supply to a motor should include a disconnect switch, short circuit current fuse or breaker protection, motor starter (controller) and correctly sized thermal elements or overload relay protection.

Short circuit current fuses or breakers are for the protection of the branch circuit. Starter or motor controller overload relays are for the protection of the motor.

Each of these should be properly sized and installed per the National Electrical Code and local codes.

Properly ground the motor – See GROUNDING.

Terminal Box

Remove the appropriate knockout. For terminal boxes without a knockout, either a threaded power-conduit entry hole is provided or the installer is responsible for supplying a correctly sized hole.

The majority of terminal boxes can be rotated in place to allow power lead entry from the 3, 6, 9 or 12 o'clock direction.

Motor Connection

All single speed and two-speed Lincoln motors are capable of across-the-line or autotransformer starting. Reference the lead connection diagram located on the nameplate or inside of the terminal box cover.

Single speed motors have reduced voltage start capability per the following chart.

Number of Motor Leads	Number of Rated Voltages	Lead Numbers	YDS	PWS
3	Single	1-3	No	No
6	Single	1-3, 7-9	No	Yes
	Dual	1-6	Yes ⁽¹⁾	No
9	Dual	1-9	No	No
12	Single	1-12	Yes	Yes
	Dual	1-12	Yes	No ⁽²⁾

(1) YDS capability on lower voltage only.

(2) PWS capability on lower voltage only, 1200 RPM, 324T-365T steel frame motors with Model Number efficiency letters of "S" or "H".

Contact Customer Service at 1-800-668-6748 (phone), 1-888-536-6867 (fax) or mailbox@lincolnmotors.com (e-mail) for a copy of across-the-line and other reduced voltage start connection diagrams.

Connection Diagram 1

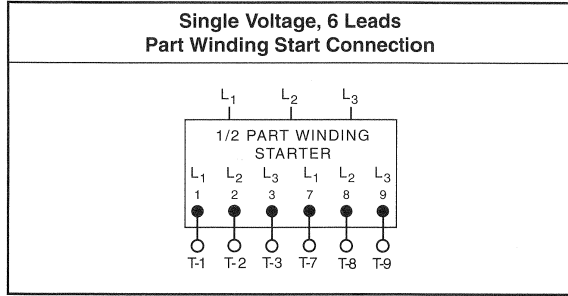

Connection Diagram 2

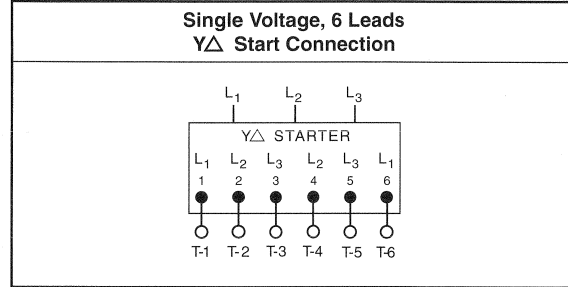

Connection Diagram 3

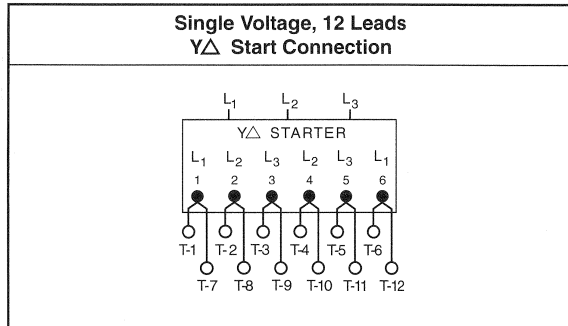

Connection Diagram 4

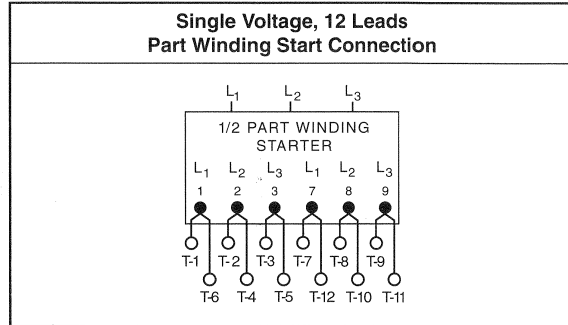

Connection Diagram 5

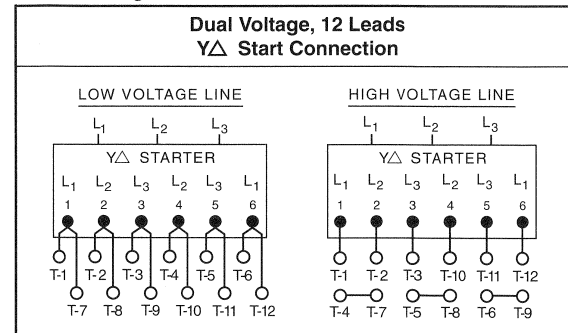

Space Heater (option)

Leads for space heaters are identified as H1 and H2. Heater voltage and watts are marked on the motor nameplate and should be checked prior to connection to power source.

Thermostat (option)

Leads for thermostats (normally closed, automatic reset contacts) are identified as P1 and P2. Connect these to a relay or signaling device. Motor line current cannot be handled by the thermostat.

Table 1 — Thermostat Contact Ratings

Voltage (60 Hz)	110V	220V
Max. Cont. Current (amps)	3.0	1.5
Min. Cont. Current (amps)	0.2	0.1

Thermistor (option)

Leads for thermistors are identified as P3 and P4. Thermistors require connection to Texas Instruments® Control Module Model 32AA or its equivalent for proper operation. This item may be purchased from Lincoln - see LC100 catalog.

Brake (option)

Carefully read and fully understand the instructions supplied by the brake manufacturer (see inside of brake housing or separately enclosed sheet). Contact the brake manufacturer for additional information.

GROUNDING

 **WARNING**



ELECTRIC SHOCK can kill.



- **Connect the motor frame to a good earth ground per the National Electrical Code and local codes to limit the potential to ground in the event of contact between live electrical parts and the metal exterior.**

Lincoln motors may be electrically connected to earth ground using a terminal box mounting screw or a separate grounding screw when provided. Both are accessible inside the mounted terminal box. When a bronze mounting screw is supplied, always use it as the grounding point. In making the ground connection, the installer should make certain that there is a good electrical connection between the grounding lead and the motor.

6. OPERATION

Three phase squirrel cage induction motors will operate successfully, but not necessarily in accordance with nameplate ratings, at voltages 10 percent above or below nameplated value at the design frequency.

 **WARNING**

MOVING PARTS can injure.

- **Before starting the motor, remove all unused shaft keys and loose rotating parts to prevent them from flying off and causing bodily injury.**
- **Keep away from moving parts.**

ELECTRIC SHOCK can kill.

- **Do not operate with covers removed.**
- **Do not touch electrically live parts.**

After checking that the shaft key is secure, operate the motor free of load and check the direction of rotation. If the motor rotates in the wrong direction, interchange any two supply leads.

Couple the motor to its load and operate it for a minimum of one hour. During this period, check for any unusual noise or thermal conditions. Check the actual operating current to be sure that the nameplate current times service factor is not exceeded for steady continuous loads.

7. MAINTENANCE

 **WARNING**



ELECTRIC SHOCK can kill.

- **Internal parts of the motor may be at line potential even when it is not rotating.**
- **Disconnect all input power to the drive and motor before performing any maintenance.**

Lincoln motors have been designed and manufactured with long motor life expectancy and trouble-free operation in mind.

Periodically inspect the motor for excessive dirt, friction or vibration. Dust may be blown from an inaccessible location using compressed air. Keep the ventilation openings clear to allow free passage of air. Make sure the drain holes in the motors are kept open and the shaft slinger is positioned against the end bracket. Grease or oil can be wiped by using a petroleum solvent.

Overheating of the bearings caused by excessive friction is usually caused by one of the following factors:

1. Bent shaft.
2. Excessive belt tension.
3. Excessive end or side thrust from the gearing, flexible coupling, etc.
4. Poor alignment.

Damaging vibrations can be caused by loose motor mountings, motor misalignment resulting from the settling or distortion of the foundation, or it may be transmitted from the driven machine. Vibration may also be caused by excessive belt or chain tension.

BEARING SYSTEM

Lincoln motors have a high quality, premium design bearing system. Bearing sizes and enclosures are identified on most motor nameplates. The majority are double-shielded, deep-groove ball bearings. Double-sealed ball bearings are used on some motors in frames 56 and 143T thru 145T. A drive-end cylindrical roller bearing is standard on Crusher Duty motors, frames 405T and larger.

Lubrication instructions and/or grease specifications provided on the motor supersede the following information.

In general, the motor's bearing system has sufficient grease to last indefinitely under normal service conditions. For severe or extreme service conditions, it is advisable to add one-quarter ounce of grease to each bearing per the schedule listed in Table 2. Use a good quality, moisture-resistant, polyurea-based grease such as Chevron SRI #2. Lithium based greases are not compatible with polyurea-based greases; mixing the two types may result in the loss of lubrication.

Motors designed for low ambient applications have bearings with special low temperature grease. Use Beacon 325 lithium based grease or equivalent per the appropriate interval in Table 2.

Motors designed for high ambient applications have bearings with special high temperature grease. Use Dow Corning DC44 silicone grease or equivalent per the interval in Table 2 under "Extreme".

Severe Service: Operating horizontally, 24 hours per day, vibration, dirty, dusty, high humidity, weather exposure, or ambient temperatures from 104-130°F (40-55°C).

Extreme Service: Operating vertically, heavy vibration or shock, heavy duty cycle, very dirty or ambient temperatures from 130-150°F (55-65°C).

Table 2 : Bearing Lubrication Intervals

Motor Syn Speed	Motor Horsepower	Service Conditions	
		Severe	Extreme
BALL BEARINGS			
1800 RPM and slower	1/4 to 7-1/2 HP	2 years	6 months
	10 to 40 HP	1 year	3 months
	50 HP and up	6 months	3 months
above 1800 RPM	all sizes	3 months	3 months
ROLLER BEARINGS			
all speeds	all sizes	3 months	3 months

When adding lubricant, keep all dirt out of the area. Wipe the fitting completely clean and use clean grease dispensing equipment. More bearing failures are caused by dirt introduced during greasing than from insufficient grease.

If the motor is equipped with a relief port or tube, make certain it is open and free of caked or hardened grease. Before replacing relief plugs, allow excess grease or pressure to vent by running the motor for several minutes after lubrication.

⚠ CAUTION

- LUBRICANT SHOULD BE ADDED AT A STEADY MODERATE PRESSURE. IF ADDED UNDER HEAVY PRESSURE BEARING SHIELD(S) MAY COLLAPSE.
- DO NOT OVER GREASE.

PARTS

All parts should be ordered from Authorized Motor Warranty Stations. Call your Lincoln Motors Sales Office for location and phone number. A "Service Directory" listing all Authorized Motor Warranty Stations by geographic location is available; request Bulletin SD-6. These shops stock GENUINE Lincoln replacement parts and have factory trained personnel to service your motor.

8. WHO TO CALL

For the location and phone number of the Lincoln Motors District Sales Office nearest you, check your local Yellow Pages or call 1-800-MOTOR-4-U (1-800-668-6748) or visit our web site at www.lincolnmotors.com.



LINCOLN MOTORS
 Cleveland OH 44117-2525 USA

Tel: 1-800-MOTOR-4-U (668-6748)
 Fax: 1-888-536-6867
 Web: www.lincolnmotors.com
 E-Mail: mailbox@lincolnmotors.com

IM566-A December 1999

9. WARRANTY

Lincoln Motors, the Seller, warrants all new *standard* motors and accessories thereof against defects in workmanship and material provided the equipment has been properly cared for and operated under normal conditions. All warranty periods begin on the date of shipment to the original purchaser. Warranty periods for **low voltage (< 600 V)** motors are defined in the following chart. The warranty period for **medium voltage (> 600 V)** motors is one year on sine-wave power. Contact Lincoln for warranty period on PWM power.

Model Number Prefix	Efficiency Code(s)	Frame Sizes	Warranty Period	
			Sine-Wave Power	PWM Power
AA, AF, AN	S, P, B	143T-286T	5 Yrs	2 Yrs*
CF, SD	M	143T-215T	2 Yrs	1 Yr
CF, CN, CS, CP	E, H, P, B	143T-449T	5 Yrs	2 Yrs*
		182U-449U	5 Yrs	2 Yrs*
C5, C6	H, P	M504-689	3 Yrs	Contact Lincoln #
MD, SE	S	284T-445T	5 Yrs	1 Yr
RC, RJ, SC	H	56-145T	5 Yrs	2 Yrs*
RD, RF	S	56-56H	5 Yrs	2 Yrs*
REW, SEW	S	56-256T	1 Yr	1 Yr
SD, SF	S, H, P, B	143T-449T	5 Yrs	2 Yrs*
Field Kits and Accessories			5 Yrs	

* Applies to motors with a service factor of 1.15 or higher. Motors with a 1.0 service factor have a 1 year warranty on PWM power.

If the Buyer gives the Seller written notice of any defects in equipment within any period of the warranty and the Seller's inspection confirms the existence of such defects, then the Seller shall correct the defect or defects at its option, either by repair or replacement F.O.B. its own factory or other place as designated by the Seller. The remedy provided the Buyer herein for breach of Seller's warranty shall be exclusive.

No expense, liability or responsibility will be assumed by the Seller for repairs made outside of the Seller's factory without written authority from the Seller.

The Seller shall not be liable for any consequential damages in case of any failure to meet the conditions of any warranty. The liability of the Seller arising out of the supplying of said equipment or its use by the Buyer, whether on warranties or otherwise, shall not in any case exceed the cost of correcting defects in the equipment in accordance with the above guarantee. Upon the expiration of any period of warranty, all such liability shall terminate.

The foregoing guarantees and remedies are exclusive and except as above set forth there are no guarantees or warranties with respect to accessories or equipment, either expressed or arising by option of law or trade usage or otherwise implied, including with limitation the warranty of merchantability, all such warranties being waived by the Buyer.

- indicates change since last printing.



APPENDIX VI

Oilgear Type PVWJ Pump Manuals

**OILGEAR TYPE "PVWJ" PUMPS -
PVWJ-011/-014/-022/-025/-034/-046/-064/
-076/-098/-130
SERVICE INSTRUCTIONS**

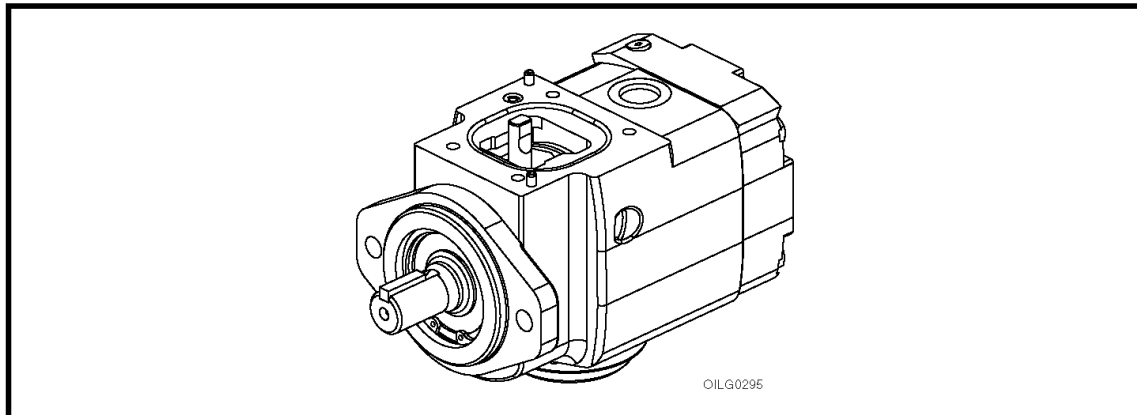

Figure 1. Typical Oilgear "PVWJ" Open Loop Pump

PURPOSE OF INSTRUCTIONS

These instructions will simplify the installation, operation, maintenance and troubleshooting of Oilgear type "PVWJ" pumps.

Become familiar with the construction, principle of operation and characteristics of your pump to help you attain satisfactory performance, reduce shut-down and increase the pump's service life. Some pumps have been modified from those described in this bulletin and other changes may be made without notice.

REFERENCE MATERIAL

Fluid Recommendations	Bulletin 90000
Contamination Evaluation Guide.....	Bulletin 90004
Filtration Recommendations	Bulletin 90007
Piping Information	Bulletin 90011
Proper Installation of Vertical Pumps	Bulletin 90014
Alternate Remote Compensating of Single/Multiple Load Sense Pumps	DS-47974-A
PVWJ Open Loop Pumps, Application Guidelines.....	Bulletin 847085
PVWJ Open Loop Pumps, Sales	Bulletin 47085

(continued)

PVWJ BASIC PUMP INSTALLATIONS

PVWJ A Frame (PVWJ-011/-014/-022) w/ Rear Ports.....	DS-47480
PVWJ A Frame (PVWJ-011/-014/-022) w/ Side Ports	DS-47481
PVWJ A Frame (PVWJ-011/-014/-022) w/ Side Ports & Thru Shaft	DS-47482
PVWJ B Frame (PVWJ-025/-034/-046) w/ Rear Ports.....	DS-47483
PVWJ B Frame (PVWJ-025/-034/-046) w/ Side Ports	DS-47484
PVWJ B Frame (PVWJ-025/-034/-046) w/ Side Ports & Thru Shaft	DS-47485
PVWJ C Frame (PVWJ-064) w/ Rear Ports	DS-47486
PVWJ C Frame (PVWJ-064) w/ Side Ports & w/ or w/o Thru Shaft.....	DS-47487
PVWJ C Frame (PVWJ-076/-098/-130) w/ Rear Ports	DS-47488
PVWJ C Frame (PVWJ-076/-098/-130) w/ Side Ports & w/ or w/o Thru Shaft	DS-47489

PVWJ PUMP CONTROL INSTRUCTIONS

“P-1NN” and “P-LNN” Pressure Compensator for PVWJ-011/-014/-022	Bulletin 947633
“P-1NN” and “P-LNN” Pressure Compensator for PVWJ-025/-034/-046	Bulletin 947634
“P-1NN” and “P-LNN” Pressure Compensator for PVWJ-064/-076/-098/-130 ..	Bulletin 947635
“P-1NN/F” and “P-LNN/F” Pressure Compensator w/ Load Sense for PVWJ-011/-014/-022	Bulletin 947636
“P-1NN/F” and “P-LNN/F” Pressure Compensator w/ Load Sense for PVWJ-025/-034/-046	Bulletin 947637
“P-1NN/F” and “P-LNN/F” Pressure Compensator w/ Load Sense for PVWJ-064/-076/-098/-130	Bulletin 947638
“P-CNN” and “P-KNN” Soft Start Pressure Compensator for PVWJ-011/-014/-022	Bulletin 947639
“P-CNN” and “P-KNN” Soft Start Pressure Compensator for PVWJ-025/-034/-046	Bulletin 947640
“P-CNN” and “P-KNN” Soft Start Pressure Compensator for PVWJ-064/-076/-098/-130	Bulletin 947641
Dual Pump Adapters for PVWJ Pumps (all sizes)	DS-47490
Alternate Remote Compensating of Single or Multiple Load Sense Pump	DS-47974-A

PVWJ PUMP CONTROL INSTALLATIONS

“P-1NN” and “P-LNN” Pressure Compensator for PVWJ-011/-014/-022	DS-47984
“P-1NN” and “P-LNN” Pressure Compensator for PVWJ-025/-034/-046	DS-47985
“P-1NN” and “P-LNN” Pressure Compensator for PVWJ-064/-076/-098/-130	DS-47986
“P-1NN/F” and “P-LNN/F” Pressure Compensator w/ Load Sense for PVWJ-011/-014/-022	DS-47987
“P-1NN/F” and “P-LNN/F” Pressure Compensator w/ Load Sense for PVWJ-025/-034/-046	DS-47988
“P-1NN/F” and “P-LNN/F” Pressure Compensator w/ Load Sense for PVWJ-064/-076/-098/-130	DS-47989
“P-CNN” and “P-KNN” Soft Start Pressure Compensator for PVWJ-011/-014/-022	DS-47990
“P-CNN” and “P-KNN” Soft Start Pressure Compensator for PVWJ-025/-034/-046	DS-47991
“P-CNN” and “P-KNN” Soft Start Pressure Compensator for PVWJ-064/-076/-098/-130	DS-47992
PVWJ Remote Circuit Drawing “P-1NN/F” or “P-LNN/F” Single Pressure w/ Load Sense Control	DS-47491

Read and understand this entire instruction sheet before repairing, or adjusting your Oilgear product.

Those who use and maintain this equipment must be thoroughly trained and familiar with the product. If incorrectly used or maintained, this product and its equipment can cause severe injury.

SAFETY SYMBOLS

The following signal words are used in this instruction sheet to identify areas of concern where your safety may be involved. Carefully read the text and observe any instructions provided to ensure your safety.

DANGER

THIS SIGNAL WORD INDICATES AN IMMEDIATELY HAZARDOUS SITUATION WHICH, IF NOT AVOIDED, WILL RESULT IN DEATH OR SERIOUS INJURY.

WARNING

This signal word indicates a potentially hazardous situation which, if not avoided, could result in death or serious injury.

CAUTION

This signal word indicates that a potentially hazardous situation exists which, if not avoided, may result in damage to equipment or minor personal injury.

NOTE *While not directly relevant to the topic being discussed, the NOTE is used to emphasize information provided, or provide additional information which may be of benefit.*

WARNING

This service information is designed for the maintenance of your Oilgear product. It contains the information on the correct procedures determined by Oilgear for the safe manner of servicing. Always keep this instruction sheet in a location where it is readily available for the persons who use and maintain the product. Additional copies of this instruction sheet are available through the Oilgear Company. Contact us at 414-327-1700 or visit our website: www.oilgear.com. Please contact us if you have any questions regarding the information in this instruction bulletin.

NOTE *The cleanliness of working on this pump or the hydraulic system is extremely important to the safety and reliability of the pump and the system. Always make sure the fittings are clean on the outside before removing them from their connections, are capped and plugged when removed and placed in a clean rag or container until they are reinstalled.*

WARNING

Some service operations may require special tools or equipment. If you require information on these items, please contact Oilgear before attempting these repairs and service operations.

WARNING

Read, understand, and follow the safety guidelines, dangers, and warnings contained in this instruction sheet to promote reliable operation and prevent serious personal injury.

WARNING

DO NOT attempt to service this machinery in an environment where safety regulations are not established and in place.

WARNING

DO NOT operate the hydraulic system if a leak is present. Serious injury may result.

WARNING

Hydraulic systems operate under very high-pressure. Hydraulic fluid escaping from a pressurized system can penetrate unprotected body tissue. DO NOT inspect for hydraulic leaks with bare hands or other exposed body parts. As a minimum, wear leather gloves prior to inspecting for leaks and use cardboard or wood. If leaks are present, relieve pressure and allow system to cool prior to servicing. If injured by escaping hydraulic oil, contact a physician immediately. Serious complications may arise if not treated immediately. If you have questions regarding inspecting for hydraulic leaks, please contact Oilgear prior to servicing.

WARNING

Hydraulic hoses and tubing must be inspected on a daily basis for leaks, cuts, abrasions, damage and improper clearance along any mounting frame for hidden damage before the unit is put into service. Replace damaged hoses or hoses you suspect are damaged before the system is returned to service! Hoses must be replaced every two years. Failure to properly inspect and maintain the system may result in serious injury.

WARNING

Hydraulic systems are hot. DO NOT TOUCH! Serious personal injury may result from hot oil. When you have completed working on the hydraulic system, thoroughly clean any spilled oil from the equipment. Do not spill any hydraulic fluids on the ground. Clean any hydraulic fluids from your skin as soon as you have completed maintenance and repairs. Dispose of used oil and system filters as required by law.

WARNING

Use correct hoses, fittings, and adapters with the correct SAE rating when replacing hoses to prevent possible serious injury. Always replace hoses, fittings, and adapters with replacements that have a proper, suitable, working pressure rating. Replacement hoses must be of the correct length and must comply with the hose manufacturer's and Oilgear's installation guidelines and recommendations.

WARNING

Hydraulic hoses have the SAE ratings marked on the hose to assist you in selecting the correct hose. The same manufacturer must supply any replacement hydraulic hoses and fitting assemblies. As an example: Brand "X" hose and brand "Y" fitting will not normally be compatible. No "Twist" is allowed in the hydraulic hoses. "Twist" may result in premature hose failure. This can cause serious injury. Please contact Oilgear for assistance when required.

WARNING

Hydraulic cylinders can be holding a function in a certain position when the pump is OFF. An example of this is a function being held in the lift or partial lift position by the cylinders. If a hydraulic line is removed or the hydraulic circuits or controls are being worked on, gravity may allow the function being held in position to drop. All workers and personnel must remain clear of these areas when working on or operating the hydraulic system. Block and secure all devices and functions which apply before beginning work or operation. Failure to comply with this can result in serious injury or death.

WARNING

Any hydraulic pipe which is replaced must conform to SAE J1065 specifications. If incorrect hydraulic pipe is installed, the hydraulic system may fail, causing serious injury. Damaged or leaking fittings, pipes or hoses must be replaced before the system is returned to service.

WARNING

DO NOT heat hydraulic pipe. The carbon content of this steel tube is such that if heated for bending, and either water or air quenched, the pipe may lose its ductility and thereby be subject to failure under high-pressure conditions. Serious injury can result. Damaged or leaking pipes must be replaced before the system is returned to service. Please contact Oilgear if you require assistance or have questions.

WARNING

All hydraulic pressure must be relieved from the hydraulic system prior to removing any components from the system. To relieve the hydraulic pressure from the hydraulic system, turn off the motor and operate the control panel with the key in the ON position. Failure to comply can result in serious injury. If you have any questions concerning relieving the hydraulic pressure from the system, please contact Oilgear.

⚠ WARNING

Hydraulic components can be heavy. Use caution while lifting these components. Serious personal injury can be avoided with proper handling of the components.

⚠ WARNING

Please contact Oilgear if you require assistance, when performing hydraulic test procedures, use the proper hydraulic gauges. Installing an incorrect test gauge could result in serious injury if the gauge fails. Use properly rated hydraulic hoses to allow the test gauge to be read away from moving parts and functions.

⚠ WARNING

Increasing hydraulic pressure beyond the recommendations may result in serious damage to the pump and system or serious personal injury and may void the Oilgear Warranty. If you have questions concerning hydraulic pressures or testing procedures, please contact Oilgear before attempting the test procedures or making adjustments.

⚠ WARNING

An Oilgear pump or pump control must not be modified in any way without authorization from Oilgear. Modifications may not comply with safety standards, including ANSI safety standards, and may result in serious personal injury. Please contact Oilgear if you require assistance.

⚠ WARNING

DO NOT enter under hydraulic supported equipment unless they are fully supported or blocked. Failure to follow this procedure can result in serious injury or death.

⚠ WARNING

Any Oilgear pump safety decals must be replaced anytime they are damaged, missing, or cannot be read clearly. Failure to have proper decals in place can result in serious injury or death. (If you require safety decals, please contact Oilgear for replacement safety decals, at no charge.)

⚠ WARNING

Be sure everyone is clear of the area around the hydraulic system before operating after servicing. Remain attentive at all times when operating to check your work until you are completely sure it is safe to return to service. Failure to heed this warning may result in serious personal injury or death.

⚠ WARNING

Wear the proper protective clothing when operating, servicing or maintaining the hydraulic system or the Oilgear pump. Wear the correct protective gear, safety glasses, gloves, and safety shoes. Serious injury can result without proper protective gear.

⚠ WARNING

Make sure to keep hands and feet and other parts of your body clear of revolving or moving parts. Failure to comply can cause serious injury.

⚠ WARNING

DO NOT wear watches, rings, or jewelry while working with electrical and mechanical equipment. These items can be hazardous and can cause serious and painful injuries if they come into contact with electrical wires, moving parts, or hydraulic equipment.

PREPARATION AND INSTALLATION

MOUNTING

Pump Without Reservoir - The pump can be mounted in any position. But, the recommended mounting position is with the drive shaft on a horizontal plane and the case drain port 1 on the top side. Secure the pump to a rigid mounting surface. Refer to the referenced Oilgear Piping Information Bulletin 90011.

Pump With Reservoir - These pumps are usually fully piped and equipped. It may be necessary to connect to a super-charge circuit when used. Mount reservoir on level foundation with the reservoir bottom at least 6 inches (152 mm) above floor level to facilitate fluid changes.

PIPING AND FITTINGS

Refer to the referenced Oilgear Piping Information Bulletin 90011 and individual circuit diagram before connecting the pump to the system. Inlet velocity must not exceed 5 fps (1,5 mps). Inlet should be unrestricted and have a minimum of fittings.

NOTE

DO NOT use an inlet strainer.

Arrange line from "case drain" so the case remains full of fluid (non-siphoning). Case pressure must be less than 25 psi (1,7 bar). For higher case pressures and the special shaft seals required, contact our Customer Service. Each drain line must be a separate line, unrestricted, full sized and connected directly to the reservoir below the lowest fluid level. Make provisions for opening this line without draining (siphoning) reservoir.

WARNING

Running the pump in NEUTRAL position (zero delivery) for extended periods without a supercharge circuit can damage the pump. The system and pump must be protected against overloads by separate high-pressure relief valves. Install bleed valve(s) at the highest point(s) in system.

POWER

Power is required in proportion to volume and pressure used. Motor size recommendations for specific applications can be obtained from The Oilgear Company. Standard low starting torque motors are suitable for most applications.

CAUTION

DO NOT start or stop unit under load unless system is approved by Oilgear. It may be necessary to provide delivery bypass in some circuits.

DRIVE

Verify rotation direction plate on the pump's housing. Clockwise pumps must be driven clockwise and counterclockwise pumps must be driven counterclockwise. Use direct drive coupling. Size and install coupling per manufacturer's instructions.

CAUTION

DO NOT drive the coupling onto the pump drive shaft. If it is too tight, it may be necessary to heat coupling for installation. Refer to manufacturer's instructions.

Misalignment of pump shaft to driver's shaft should not exceed 0.005 inches (0,13 mm) Total Indicator Readout (TIR) in any plane.

FILTRATION

Keep the fluid clean at all times to ensure long life from your hydraulic system. Refer to the referenced Oilgear Filtration Recommendations bulletin 90007 and Oilgear Contamination Evaluation Guide Bulletin 90004. Oilgear recommends use of a filter in the pressure or return line. Replace filter element(s) when the filter condition indicator reaches change area at normal fluid temperature. Drain and thoroughly clean filter case. Use replacement element(s) of same beta 10 ratio (normally a ratio of 4 with hydraulic oils).

FLUID COOLING

When the pump is operated continuously at the rated pressure or frequently at peak load, auxiliary cooling of the fluid may be necessary. Fluid temperature should not exceed limits specified in the referenced Oilgear Fluid Recommendations Bulletin 90000.

AIR BREATHER

On most installations, an air breather is mounted on top of fluid reservoir. It is important for the breather to be the adequate size to allow air flow in and out of reservoir as fluid level changes. Keep the breather case filled to the "fluid level" mark. About once every six months, remove cover, wash screen in solvent and allow screen to dry, clean and refill case to level mark and install screen. Refer to the manufacturer's recommendations.

FLUID, FILLING AND STARTING RECOMMENDATIONS

Refer to instruction plate on the unit, reservoir, machine and/or reference, fluid recommendations bulletin. Fire resistant fluids and phosphate ester fluids can be used in accordance with fluid manufacturer's recommendations.

1. Pump all fluid into reservoir through a clean (beta 10 ratio of 4 or more) filter. Fill reservoir to, but not above, "high level" mark on the sight gauge.
2. **Remove case drain line and fill pump case with hydraulic fluid.**
3. Turn drive shaft a few times by hand with a spanner wrench to make sure parts rotate.

Unit	Approximate torque to turn drive shaft
-011/-014/-022	1.7-2.1 ft·lbs (2,3-2,8 N·m)
-025/-034/-046	2.9-3.3 ft·lbs (4,0-4,5 N·m)
-064/-076/-098/-130	7.9-8.3 ft·lbs (18,8-11,3 N·m)

Table 1. Torque to Turn Shaft

With pump under "no load" or with pump control at NEUTRAL:

4. Turn drive unit ON and OFF several times before allowing pump to reach full speed. The system can usually be filled by running the pump and operating the control.
5. The fluid level in the reservoir should decrease. Stop the pump. **DO NOT** allow the fluid level to go beyond the "low level." If the level reaches the "low level" mark, add fluid and repeat step.

NOTE

With differential (cylinder) systems, the fluid must not be above "high level" when the ram is retracted or below "low level" when extended. Bleed air from the system by loosening connections or opening petcocks at the highest point in the system. Close connections or petcocks tightly when solid stream of fluid appears.

SPECIFICATIONS

NOTE

Refer to reference material, pump control material and individual application circuit for exceptions.

FRAME	UNIT	THEORETICAL MAXIMUM DISPLACEMENT		RATED CONTINUOUS PRESSURE		MAXIMUM PRESSURE		FLOW RATE at 1800 rpm, rated continuous pressure and 14,7 psia (1.0 bar) inlet condition		MAXIMUM INLET PRESSURE* psia (bar)			MAXIMUM SPEED** rpm	POWER INPUT at rated continuous pressure & 1800 rpm	
		in ³ /rev	ml/rev	psi	bar	psi	bar	gpm	l/mi	1200 rpm	1500 rpm	1800 rpm		hp	kw
A	011	0.66	10,8	5000	344,8	5800	400,0	4.2	15,9	5.4 (.37)	5.7 (.39)	6.1 (.42)	3000	16.3	12,2
	014	0.86	14,1	4000	275,9	4500	310,3	5.9	22,4	5.5 (.38)	5.9 (.41)	6.4 (.44)	3000	17.7	13,2
	022	1.35	22,1	3000	206,9	3500	241,4	9.5	36,0	5.5 (.38)	6.0 (.41)	7.0 (.48)	3000	20.2	15,1
B	025	1.55	25,4	5000	344,8	5800	400,0	10.9	41,3	7.0 (.48)	7.3 (.50)	8.2 (.57)	3000	36.5	27,2
	034	2.06	33,8	3500	241,4	4000	275,9	14.7	55,7	7.0 (.48)	7.6 (.52)	8.4 (.58)	3000	35.5	26,5
	046	2.83	46,4	2500	172,4	3000	206,9	20.6	78,1	7.2 (.50)	7.9 (.54)	9.0 (.62)	2400	35.0	26,1
C	064	3.88	63,6	5000	344,8	5800	400,0	27.4	103,8	7.6 (.59)	8.5 (.59)	9.5 (.66)	2400	95.1	70,9
	076	4.67	76,5	3500	241,4	4000	275,9	33.7	127,7	8.0 (.55)	8.6 (.59)	9.6 (.66)	2400	80.4	60,0
	098	6.00	98,3	2500	172,4	3000	206,9	43.3	164,1	7.6 (.52)	8.6 (.59)	9.8 (.68)	2400	74.1	55,3
	130	7.94	130,2	1500	103,4	2000	137,9	58.2	220,3	8.0 (.55)	9.3 (.64)	14.5 (1,00)	1800	64.0	47,8

* For higher speeds see suction curves.

** Minimum speed 600 rpm

Case pressure should be less than 25 psi (1,7 bar). For higher pressure, consult factory.

Higher speeds available - consult factory.

Table 2. Nominal Performance Data with 150-300 SSU viscosity fluids.

Frame	Unit	Length		Width		Height		Weight	
		inches	mm	inches	mm	inches	mm	lbs.	kg
A	011/-014/-022	7.20	182,9	4.32	109,7	4.50	114,3	32	14,5
B	025/-034/-046	8.50	215,9	5.80	147,3	6.11	155,2	68	30,9
C	064/-076/-098/-130	10.44	265,2	6.76	171,7	7.18	182,4	103	46,8

All dimensions (without controls) are for rear ported units. For dimensions of other configurations, contact your Oilgear Representative or see the appropriate Data Sheet.

Table 3. Nominal Dimensions and Weights without controls.

Refer to installation drawings for more detailed dimensions and port configurations.

TROUBLESHOOTING

PROBLEM	CAUSES	REMEDY
Unresponsive or Unstable Control	Swashblock (201) bearing surface and/or saddle bearings (204) worn or damaged.	Inspect and replace if necessary.
	Control pin (721) and/or hole in swashblock (201) worn significantly.	
	Saddle bearing locating pins (207) broken.	
	Fluid is contaminated.	Inspect and clean if necessary. See bulletin 90007.
	Control piston orifice plugged.	See appropriate control service bulletin.
	Contamination trapped between control piston and piston bore is not allowing piston to move smoothly.	
	Contamination trapped between control spool and spool bore is not allowing spool to move smoothly.	
	Faulty remote pressure compensator circuit components.	Inspect and replace if necessary.
	Hydraulic line between remote pressure compensator components and RP port of control is too long.	Shorten line length.
Insufficient control flow.	Increase size of control piston orifice (732).	
Insufficient Outlet Volume	Swashblock (201) not stroking to desired displacement.	Inspect for obstruction and remove. Replace worn or damaged parts.
	Low input drive speed.	Refer to appropriate pump performance specifications.
	Worn or grooved cylinder barrel (101) and/or valve plate (401) mating surfaces.	Inspect and replace if necessary.
	Failed drive shaft (301).	
	Worn or damaged piston shoes (102) or swashblock (201).	
	Worn pistons and/or piston bores.	Adjust maximum volume stop CCW to increase outlet flow.
	Excessive wear or inadequately supported hydrodynamic bearing (202).	
	Maximum volume stop adjusted incorrectly.	
	Control piston stuck off stroke.	See appropriate control service bulletin.
Pressure compensator is set too close to operating pressure.		
De-strokes at Low Pressure	Pressure compensator adjustment not set correctly.	See appropriate control service bulletin.
	Control piston orifice (732) plugged.	
	Damaged or fractured control spring.	
	Severely worn control spool and/or spool bore.	
	Damaged or fractured control piston spring.	
Faulty remote pressure compensator circuit components.		
Excessive Peak Pressure	Pressure compensator is set too high.	See appropriate control service bulletin.
	Minimum volume stop is set too high.	Inspect and clean if necessary. See bulletin 90007.
	Fluid is contaminated.	
	Swashblock (201) bearing surface and/or saddle bearings (204) worn or damaged.	Inspect and replace if necessary.
	Contamination trapped between control piston and piston bore is not allowing piston to move smoothly.	See appropriate control service bulletin.
	Contamination trapped between control spool and spool bore is not allowing spool to move smoothly.	
	Hydraulic line between remote pressure compensator components and RP port of control is too long.	Shorten line length.
	Faulty remote pressure compensator circuit components.	Inspect and replace if necessary.
Restriction in drilled passages between pump outlet port and control spool.	Inspect and clean if necessary.	

Excessive Heating	Operating pump above rated or peak pressure.	Consult appropriate pump specification for pressure limitations.
	Low fluid level in reservoir.	Verify fluid level is above reservoir suction line.
	Insufficient pump inlet pressure.	Eliminate any obstructions or other pressure drops in pump inlet plumbing. Consult appropriate pump specification for inlet pressure requirements.
	Air entering pump inlet plumbing.	Eliminate leaks that would allow air to enter the fluid stream.
	Worn pistons (102) or cylinder barrel (101).	Inspect and replace if necessary.
	Worn or damaged cylinder barrel (101) and/or valve plate (401) mating surfaces.	
	Faulty circuit components (continuously blowing relief valve or a high-pressure leak).	Eliminate leak or replace faulty components.
	Insufficient cooling provisions.	Inspect heat exchanger for obstructions and remove.
Reservoir is too small.	Consult Bulletin 90050-B, Reservoir Design.	
Excessive Noise	Pump stopped or started incorrectly under load.	Verify operator procedure.
	Low fluid level in reservoir.	Verify fluid level is above reservoir suction line.
	Air entering pump inlet plumbing.	Eliminate leaks that would allow air to enter the fluid stream.
	Broken shoe/piston assembly (102).	Inspect and replace if necessary.
	Worn or damaged cylinder barrel (101) and/or hydrodynamic bearing (202) running surface.	
	Faulty circuit components (continuously blowing relief valve or a high-pressure leak).	Eliminate leak or replace faulty components.
	Insufficient pump inlet pressure.	Consult appropriate pump specification for inlet pressure requirements.
	Excessive fluid viscosity.	Consult Application Guidelines (Bulletin 847085) for maximum viscosity limitations.
Insufficient pump inlet pressure.	Eliminate any obstructions or other pressure drops in pump inlet plumbing. Consult appropriate pump specification for inlet pressure requirements.	
Pump input shaft rotating in wrong direction.	Inspect and correct drive rotation.	

PRINCIPLE OF OPERATION

The illustrations show the pump driven clockwise (right hand) from the top (plan) view.

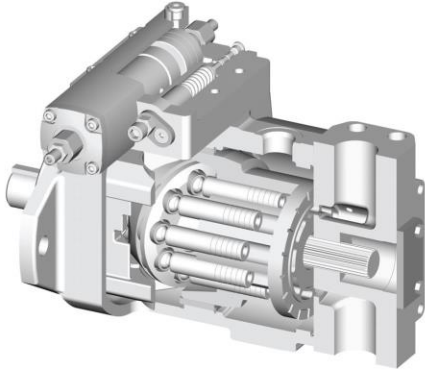

OILG0294

Figure 2. Cut-a-way of a Typical “PVWJ” Pump with Typical Control

Position B, Pump During Full Delivery FROM PORT B - Figure 3

Rotating the drive shaft (301) clockwise turns the splined cylinder, which contains the pumping pistons (102). When the cylinder rotates, the pistons move in and out within their bores as the shoes ride against the angled (C) swashblock (201).

As the cylinder rotates, the individual piston bores are connected, alternately, to the crescent shaped upper (port A) and lower (port B) in the valve plate. While connected to the upper side (suction) port A, each piston moves outward **OUT**, drawing fluid from port A into the piston bore until its outermost stroke (D) is reached. At this point, the piston bore passes from the upper crescent port A to the lower crescent port B.

While rotating across the lower crescent, each piston moves across the angled swashblock face and then each piston is forced inward **IN**. Each piston then displaces fluid through the lower crescent to port B until its innermost stroke (D) is reached. At this point, the piston bore passes from the lower to the upper crescent again and the cycle is repeated.

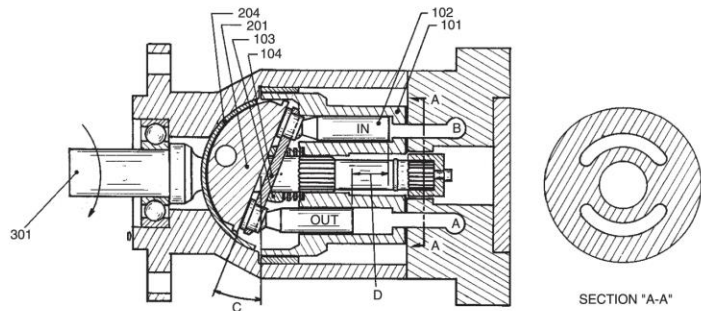

OILG-0001

Figure 3. Position B, Pump During Full Delivery From Port B

Position B/2, Pump During One Half Delivery FROM PORT B - Figure 4

This illustration shows that the angle (E) of the swashblock determines the length of the piston stroke (F), (the difference between outermost and innermost position) which determines the amount of delivery from the pump. In this case, the stroke angle (E) is one-half of the stroke, which means the piston stroke is one-half and the pump delivery is one-half.

Position N, Pump In Neutral, No Stroke, No Delivery - Figure 5

Neutral position results when the control centers the swashblock. The swashblock angle (G) is now zero and swashblock face is parallel to the cylinder face. There is no inward or outward motion of the pump pistons as piston shoes rotate around the swashblock face. With no inward and outward motion or no stroke (H), **NEUTRAL** no fluid is being displaced from the piston bores to the crescents in the valve plate and there is no delivery from pump ports.

NOTE Illustration reference numbers match the part item number in the parts list.

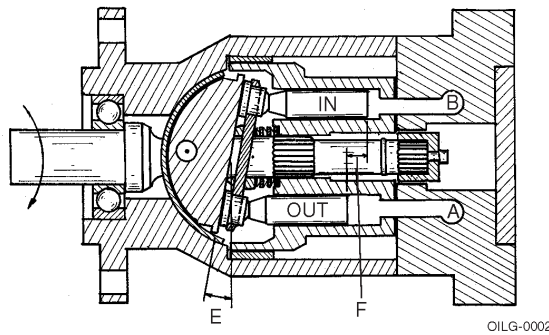

Figure 4. Position B/2, Pump During One Half Delivery From Port B

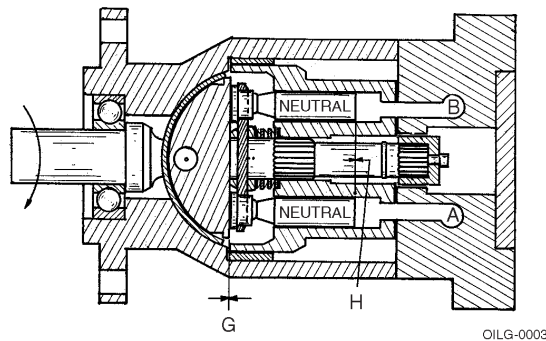

Figure 5. Position N, Pump In Neutral, No Stroke, No Delivery

TESTING AND ADJUSTING

PISTON PUMP

To check for a worn piston pump, make a leak measurement test from the case drain while the pump is under pressure. After the unit is warm, either install a flow meter in the drain line or have the flow from the drain line directed into a large container or reservoir. The pump case must remain full of fluid during this test.

WARNING

Shut the pump OFF and release pressure from the system before disassembling components. Failure to comply with these instructions could result in personal injury or death. Blocking the pressure line between the pump and the system (or pump) high-pressure relief valve will result in damage and could result in serious personal injury.

With an accurate high-pressure gauge in the pressure line, start the pump and stall (or block) output device to raise system pressure to maximum (as set by system relief valve). Read the measurement on the flow meter or time and measure the case drain flow used to fill a known size container and calculate the flow rate in terms of cubic inches per minute (cipm). The leakage should conform to **Table 4**.

CAUTION

DO NOT run a pump on stroke against a blocked output unless it is protected by a high-pressure relief valve and then run no longer than necessary to check slip. Limit discharge to prevent dropping reservoir fluid below low level.

NOTE Increasing shaft speed or a decrease in fluid viscosity will increase leakage. Manually or mechanically de-stroking the pump has a negligible effect on leakage.

NOTE Additional leakage indicates wear, but does not become critical until it impairs performance.

NOTE If testing a unit with a pressure compensator control, make sure the compensator setting is at least 500 psi above the pump outlet pressure to assure the pump is at full stroke.

Unit	Full Stroke Leakage @ Pump Outlet Pressure (psi)											
	1500 psi		2500 psi		3000 psi		3500 psi		4000 psi		5000 psi	
	cipm	lpm	cipm	lpm	cipm	lpm	cipm	lpm	cipm	lpm	cipm	lpm
011	50	2.08	70	1.1	80	1.3	100	1.6	120	2.0	200	3.3
014	90	1.5	120	2.0	140	2.3	165	2.7	200	3.3	-	-
022	120	2.0	170	2.8	200	3.3	-	-	-	-	-	-
025	105	1.7	135	2.2	150	2.4	175	2.9	210	3.4	300	4.9
034	150	2.4	210	3.4	250	4.1	300	4.9	-	-	-	-
046	230	3.8	300	4.9	-	-	-	-	-	-	-	-
064	150	2.4	205	3.4	240	3.9	275	4.5	320	5.2	460	7.6
076	200	3.3	305	5.0	375	6.1	460	7.6	-	-	-	-
098	270	4.4	460	7.6	-	-	-	-	-	-	-	-
130	530	8.7	-	-	-	-	-	-	-	-	-	-

Table 4. Nominal Case Slip at full stroke and 1800 RPM, fluid viscosity 160 SSU.

DISASSEMBLY

NOTE

The cleanliness of working on this pump or the hydraulic system is extremely important to the safety and reliability of the pump and the system.

When disassembling or assembling the pump, choose a clean, dry, dust and sand-free area where no traces of abrasive particles are in the air which can damage the pump and system. DO NOT work near welding, sandblasting, grinding benches or similar conditions.

Always make sure the fittings are clean on the outside before removing them from their connections. Make sure they are capped and plugged when removed. Place them on a clean surface and in a clean rag or container until they are reinstalled. When cleaning parts which have been disassembled, it is important to use CLEAN cleaning solvents and allow parts to dry. All tools and gauges should be clean prior to working with the system and use new, CLEAN, lint-free rags to handle and dry parts.



WARNING

DO NOT attempt to remove or install any components or assembly while the pump and system is running. Always stop the pump, shut OFF the power and release pressure from the system before servicing or testing. Be sure provisions have been made so the case drain line can be disconnected from the unit without causing the line to drain (siphon) the reservoir.

1. Disconnect case drain line from port **1** or **1A**.
2. Drain pump case through the remaining (port **1** or **1A**) on the bottom of case. If plugs are inaccessible, it may be necessary to remove the pump from the mounting and drive motor before draining it.
3. After removing the pump from the mounting and before disassembly, cap or plug all ports and clean the outside of unit thoroughly to prevent dust from entering the system. See **Figures 10** and **18**.

NOTE

Depending on what part or parts are to be inspected, it may not be necessary to completely take apart all assemblies.

CONTROL GROUP

Refer to the reference material for the information which applies to the control your pump is equipped with. Some force is required to remove the control housing.

1. Remove socket head cap screws.
2. Lift the control group assembly, with control pin, straight up from the top of the pump assembly. The control pin may or may not remain in the swashblock (**201**).
3. Remove control gasket and O-rings from the pump housing.

VALVE PLATE GROUP

If another pump is coupled to thru-shaft pumps, remove coupling half before removing valve plate.

1. Block the pump on a bench with the drive shaft facing down.
2. If applicable, remove relief valve block from valve plate.
3. Remove the valve plate (**401**) by removing four hex head cap screws (**403**) and lifting it straight up.
4. Remove O-rings.

ROTATING GROUP

⚠ WARNING

The rotating group may be heavy. Be careful not to damage cylinder wear surface which mates against the valve plate, bearing diameters or piston shoes. Use proper lifting techniques and assistance from others to prevent personal injury.

1. Place the pump in a horizontal position.
2. Remove the rotating group by turning shaft (301) slowly, while pulling the cylinder barrel (101) from the housing.
3. Identify (number) each pump piston shoe assembly (102) and its respective bore in the cylinder barrel (101) and shoe retainer (104) for easy reassembly.
4. See **Figure 6**. Lift out shoe retainer (104) with pistons (102) and remove the fulcrum ball (103) and shoe retainer spring (105).

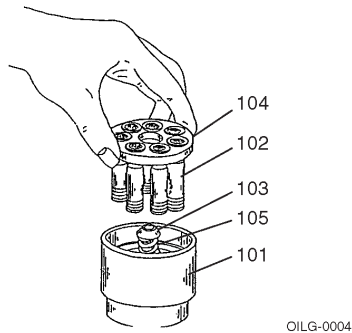

Figure 6. Rotating Group Disassembly.

5. Remove retaining ring (208) and pull the hydrodynamic bearing (202) and roll pins, if necessary, (205) from the housing. Note the position of roll pin (205) inside of case.

DRIVE SHAFT GROUP

1. Remove the drive key (303), if used and the drive shaft bearing retainer ring (305).
2. Grasp outboard end of drive shaft (301) and pull it out of the pump housing.
3. Remove the shaft seal retainer (302) and shaft seal (007) from the housing only if necessary.

SWASHBLOCK GROUP

1. Reach inside the housing and remove the swashblock (201) and saddle bearings (204).
2. If applicable, remove the saddle block (216) from the housing.

INSPECTION

Clean all parts thoroughly and allow them to dry. Inspect all seals and O-rings for hardening, cracking or deterioration. Replace if necessary or if you suspect damage. Check all locating pins for damage and springs for cracking or signs of cracking or signs of wear.

⚠ WARNING

Wear proper protective gear when using solvents or compressed air, servicing or maintaining the hydraulic system or the Oilgear pump. Wear correct protective gear, safety glasses, gloves and safety shoes. Serious injury can result without proper protective gear.

CONTROL GROUP

Refer to the reference material on pump controls. Be sure to carefully check the control pin for cracks and/or signs of fatigue. Check fit of the pin in the swashblock. It should be a slip-fit without side-play. Replace if necessary or if you suspect damage.

VALVE PLATE GROUP

Inspect the valve plate (401) surface which mates with the cylinder barrel (101) for excessive wear or scoring. Remove minor defects by lightly stoning the surface with a hard stone which is flat to within 0.001 inches (0,025 mm).

NOTE *Be sure to stone lightly. Any excessive stoning will remove the hardened surface. If wear or damage is extensive, replace the valve plate.*

ROTATING GROUP

Inspect cylinder barrel (101) piston bores and the face which mate with the valve plate for wear and scoring. Remove minor defects on the face by lightly stoning or lapping the surface.

Inspect the cylinder bearing (202) for damage and replace if necessary. Check all piston and shoe assemblies (102) to be sure they ride properly on the swashblock.

NOTE *Be sure to stone lightly. Any excessive stoning will remove the hardened surface. If wear or damage is extensive and defects cannot be removed, replace the cylinder barrel.*

See **Figure 7**. Check each shoe face for nicks and scratches, and the shoe for smooth pivot action on the piston.

NOTE *If one or more piston/shoe assembly needs to be replaced, replace all the piston/shoe assemblies. When installing new piston/shoe assemblies or the rotating group, make sure the pistons move freely in their respective bores.*

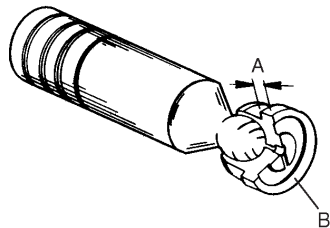

Figure 7. Piston and Shoe Inspection

- (A) All shoes must be equal within 0.001 inches (0,025 mm) at this dimension.
(B) All shoe faces must be free of nicks.

NOTE *End play should not to exceed 0.003 inches (0,076 mm) when new or 0.006 inches (0,152 mm) when worn.*

SWASHBLOCK GROUP

Inspect the swashblock (201) for wear and scoring. If defects are minor, stone the swashblock lightly. If damage is extensive, replace the swashblock.

Check the small hole in the face of the swashblock. The hole provides “porting” for the hydrostatic balance fluid of the piston/shoe assembly to be channeled through the swashblock to the face of the saddle bearing, providing pressure lubrication.

Compare the saddle bearing (204) thickness in a worn area to thickness in an unworn area. Replace saddle bearings if the difference is greater than 0.015 inches (0,4 mm).

Check the mating surface of swashblock for cracks or excessive wear. The swashblock movement in the saddle bearings must be smooth. Replace if necessary.

NOTE *Be sure to stone lightly. Any excessive stoning will remove the hardened surface. If wear or damage is extensive and defects cannot be removed, replace if necessary or if you suspect them of being bad.*

DRIVE SHAFT GROUP

Check:

- the shaft seal (007) for deterioration or cracks. Replace if necessary (push-out).
- the shaft bearing (306) for galling, pitting, binding or roughness.
- the rear shaft bushing in valve plate.
- the shaft and its splines for wear. Replace any parts necessary.
- for grooving of the shaft where the shaft seal contacts it.

ASSEMBLY

See **Figures 8, 9 and 10**. Follow the disassembly procedures in reverse for re-assembling the pump.

During assembly, install new seals and O-rings. Apply a thin film of CLEAN grease or hydraulic fluid to sealing components to ease assembly. If a new rotating group is used, lubricate thoroughly with CLEAN hydraulic fluid. Apply fluid generously to all wear surfaces.

SWASHBLOCK GROUP

If removed,

1. Press shaft seal (007) into front of pump housing.
2. Place housing on a bench with the mounting flange side down.
3. If applicable, install the saddle block (216) into the housing. Make sure the anti-rotating pin (217) aligns the saddle block correctly.
4. Grease the back side of each saddle bearing (204) and place on the pin to locate the bearings in the pump case. Make sure the pins do not protrude.
5. Insert swashblock (201) into the pump housing. Once in place, be sure the swashblock swivels in the saddle bearings. With new bearings, swiveling may be stiff and not always smooth.
6. Make sure the roll pin (205) is inserted into the cylinder bearing (202). Position the cylinder bearing so the pin is located at the same location as it was when the pump was disassembled. The bearing should fit into place with a little difficulty and be square to the axis of the pump.
7. Tap bearing into place if necessary using extreme care not to damage the bearing.
8. Insert retaining ring (208) to hold bearing in place.

NOTE

Refer to **Figure 8** and **Figure 9** for the correct orientation of the pins for the appropriate frame size.

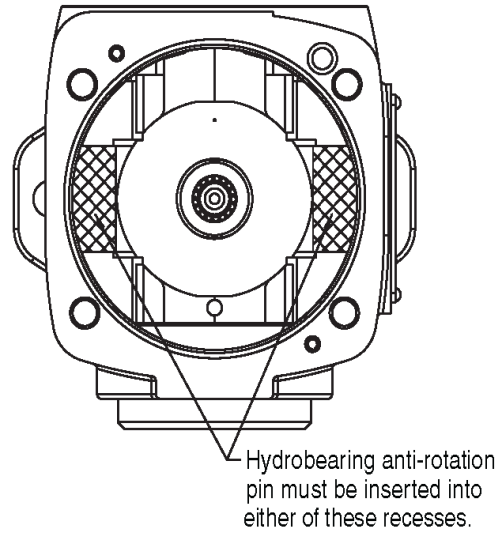

OILG0305

Figure 8. A-Frame Orientation of Pins

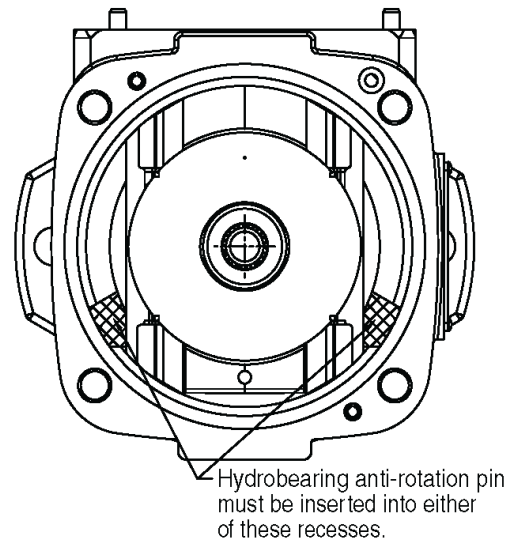

OILG0306

Figure 9. B-Frame and C-Frame Orientation of Pins

DRIVE SHAFT GROUP

1. Place the housing on its side with the axis horizontal.
2. Install the seal retainer (302).
3. Lubricate the shaft seal (007) and shaft.
4. Insert the drive shaft (301) and bearing assembly into the housing.
5. Lock in place with the drive shaft bearing retainer ring (305).

ROTATING GROUP

See Figure 6.

1. Place the cylinder barrel (101), wear surface down, on a clean cloth.
2. Place the shoe retainer spring (105) in the center of the barrel with the fulcrum ball (103) on top of it.
3. Insert the identified pistons (102) into their corresponding identified holes of the shoe retainer (104). As a unit, fit the pistons into their corresponding, identified bores in the cylinder barrel. **DO NOT FORCE.** If everything is aligned properly, the pistons will fit smoothly.

WARNING

The rotating group weight may be heavy. Be careful not to damage cylinder wear surface which mates against the valve plate, bearing diameters or piston shoes. Use proper lifting techniques and assistance from others to prevent personal injury.

The rotating group can now be carefully installed over the tail of the drive shaft (301) and into the pump housing (001).

NOTE

When installing the rotating group, support the weight of the cylinder barrel (101), as cylinder spline is passed over the tailshaft, to avoid scratching or damage.

4. Push cylinder forward until the cylinder spline reaches the drive shaft spline and rotate slightly to engage shaft splines. Continue to slide cylinder forward until it encounters the cylinder bearing (202). Lifting the tailshaft slightly helps the cylinder (101) and the cylinder bearing (202) engagement. Continue pushing the cylinder forward until the piston shoes contact the swashblock. The back of the

cylinder should slightly protrude outside the back of the pump housing.

5. Install and torque the four control screws to the appropriate value shown in **Table 5**.

RELIEF VALVE BLOCK

1. Install new O-rings on the relief block.
2. Position the relief valve block over the outlet port of the valve plate.
3. Install and torque the four screws to the appropriate value shown in **Table 5**.

VALVE PLATE GROUP

1. Place the partially assembled pump housing on a bench with the open end facing up.
2. Install new O-rings on the housing.
3. Position the valve plate (401) over the tailshaft and on pins (005) and housing.
4. Install and torque the four valve plate screws to the appropriate value shown in **Table 5**.
5. If any plugs were removed, reinstall and torque them to the appropriate value shown in **Table 5**.

CONTROL GROUP

1. Place the assembled pump on its side with the axis horizontal.
2. Install new O-rings on the housing.
3. Install the control pin into the swashblock.
4. Position the control assembly so the control pin fits into the annular slot of the control piston.
5. Assemble the control assembly to the pump assembly, making sure that both alignment pins (006) are correctly inserted into their respective holes of the control body.

NOTE

It may be necessary to mechanically position the control piston to correctly align the control on the pump.

PVWJ PUMP TORQUES

	Item Number	Description	Head Type & Size	Tightening Torque
A-Frame PVWJ-011 PVWJ-014 PVWJ-022	002	Housing Plug	3/4" Internal Hex	100 ft-lbs (136 N·m)
	403	Valve Plate Screws	3/8" Internal Hex or 9/16" External Hex	15 ft-lbs (20 N·m)
	507	Tandem Cover Screws	1/2" Internal Hex	325 in.-lbs (5 N·m)
	601	SAE #2 Plug	1/8" Internal Hex	45 in.-lbs (5 N·m)
	626	SAE #10 Plug	1" External Hex	90 ft-lbs (122 N·m)
B-Frame PVWJ-025 PVWJ-034 PVWJ-046	403	Valve Plate Screws	3/4" External Hex	37 in.-lbs (50 N·m)
	405	SAE #2 Plug	1/8" Internal Hex	45 in.-lbs (5 N·m)
	503	SAE A Tandem Mounting Screws	9/16" External Hex	28 ft-lbs (38 N·m)
		SAE B Tandem Mounting Screws	3/4" External Hex	37 ft-lbs (50 N·m)
	507	Cover Plate or Adapter Screws	1/2" External Hex	325 in.-lbs (37 N·m)
	902	Relief Valve Block Screws	3/8" Internal Hex	44 ft-lbs (60 N·m)
C-Frame PVWJ-064 PVWJ-076 PVWJ-098 PVWJ-130	403	Valve Plate Screws	14 mm Internal Hex	56 ft-lbs (76 N·m)
	503	SAE A Tandem Mounting Screws	9/16" External Hex	28 ft-lbs (38 N·m)
		SAE B Tandem Mounting Screws	3/4" External Hex	37 ft-lbs (50 N·m)
		SAE C Tandem Mounting Screws	15/16" External Hex	74 ft-lbs (100 N·m)
	507	Cover Plate Screws	1/2" External Hex	325 in.-lbs (37 N·m)
		Adapter Screws	9/16" External Hex	28 ft-lbs (38 N·m)
	601	SAE #2 Plug	1/8" Internal Hex	45 in.-lbs (5 N·m)
	902	Relief Valve Block Screws (PVWH-076/-098/-130)	3/8" Internal Hex	68 ft-lbs (92 N·m)
		Relief Valve Block Screws (PVWH-064)	1/2" Internal Hex	138 ft-lbs (187 N·m)

Table 5. PVWJ Pump Assembly Torques

CONTROL O-RING SEALS

Item Number	ARP 568 Uniform Size Number	Shore A Durometer
1008	008	70
1010	010	90
1012	012	90
1042	042	70
1138	138	70
1145	145	70
1155	155	70
1159	159	70
1219	219	90
1222	222	90
1225	225	90
1228	228	90
1237	237	70
1242	242	70
1252	252	70
1257	257	70
1500	See note 1	80
1902	902	90
1910	910	90

Note 1. 94 mm OD x 2.5 mm

Table 6. PVWJ Pump O-Ring Seals

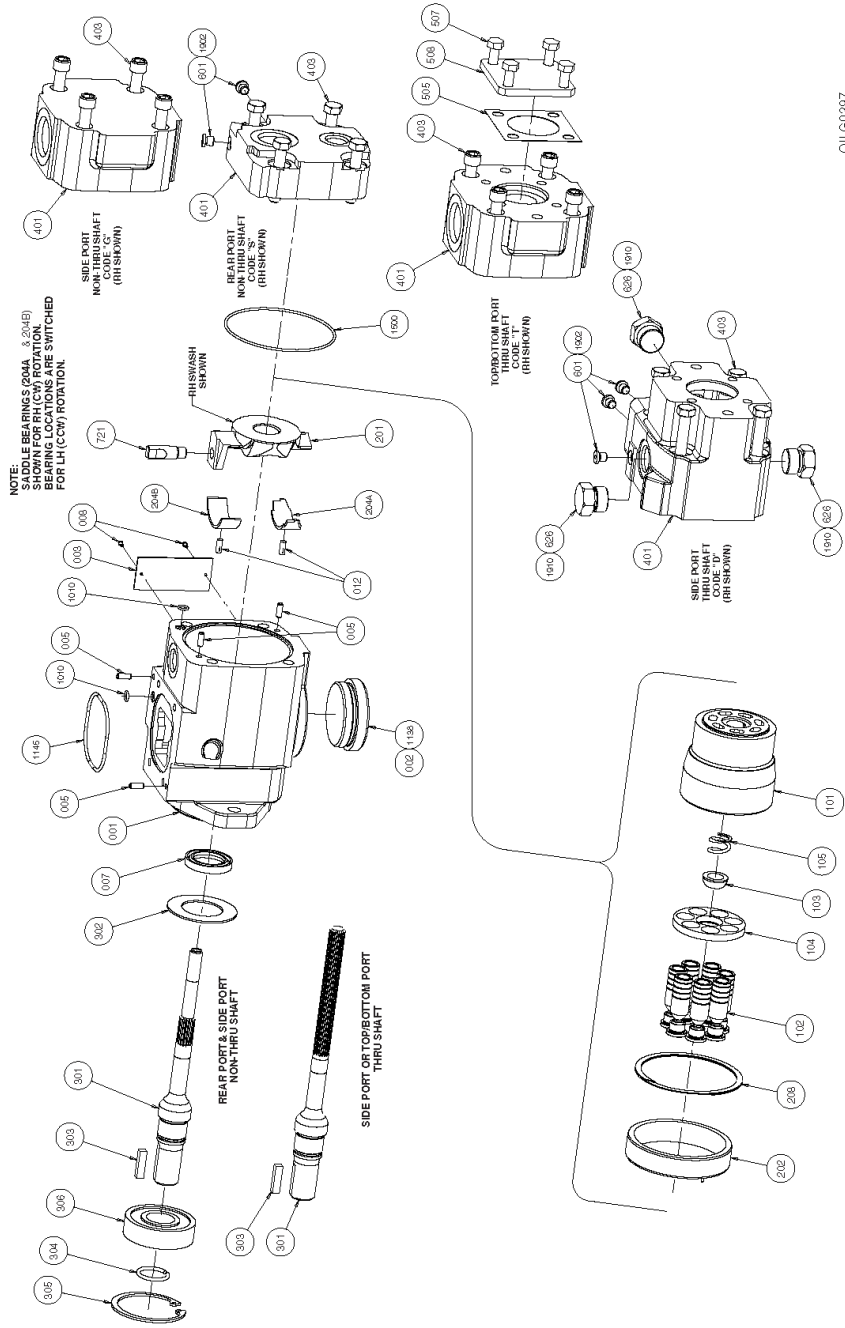

Figure 10. Exploded parts drawing, PVWJ-011/-014/-022 A-Frame (520024-101 sheet 2 of 4).

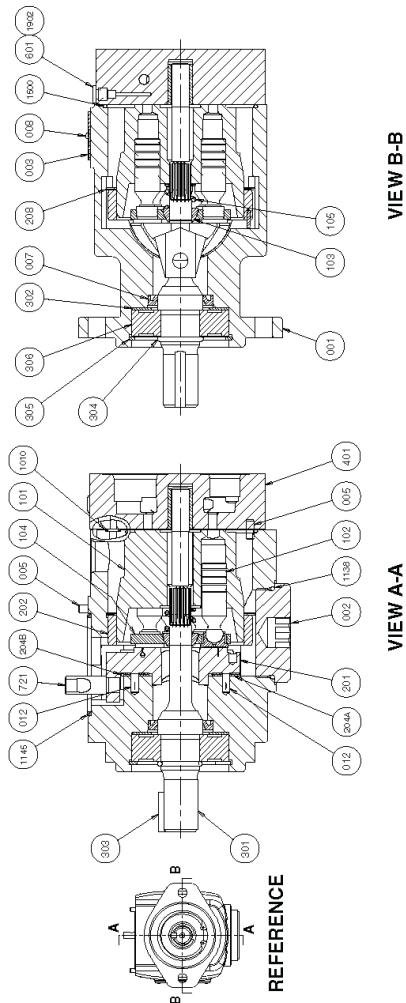

Figure 11. Cross section and plan view parts drawing, PVWJ-011/-014/-022 A-Frame (520024-101 sheet 1 of 4).

PVWJ-011/-014/-022 A-FRAME PUMP PARTS LIST

Parts used in these assemblies are per Oilgear specifications. Use only Oilgear parts to ensure compatibility with assembly requirements. When ordering replacement parts, be sure to include pump type and item serial number, bulletin number and item number. Specify type of hydraulic fluid to ensure seal and packing compatibility.

NOTE Parts drawings may not be identical to Oilgear drawings referenced.

Item	Qty.	Description
HOUSING ASSEMBLY GROUP		
001	1	Pump Housing
002	1	Plug
003	1	Name Tag
005	4	Roll Pin
007	1	Shaft Seal

008	2	Drive Screws
012	2	Saddle Bearing Locating Pin
1010	2	O-Ring
1138	1	O-Ring
1145	1	O-Ring
1500	1	O-Ring
ROTARY ASSEMBLY GROUP		
101	1	Barrel
102	7	Piston & Shoe Assembly
103	1	Fulcrum Ball
104	1	Shoe Retainer
105	1	Shoe Retainer Spring
SWASHBLOCK ASSEMBLY GROUP		
201	1	Swashblock
202	1	Hydrodynamic Bearing
204A	1	Saddle Bearing (pressure side)
204B	1	Saddle Bearing (suction side)
208	1	Retaining Ring
721	1	Control Pin

DRIVE SHAFT ASSEMBLY GROUP		
301	1	Drive Shaft
302	1	Seal Retainer
303	1	Key
304	1	Shaft Retainer Ring
305	1	Shaft Bearing Retainer Ring
306	1	Front Drive Shaft Bearing
VALVE PLATE ASSEMBLY GROUP		
401	1	Valve Plate
403	4	Screw
601	Note 1	Plug
626	Note 1	Plug
1902	Note 1	O-Ring
1910	Note 1	O-Ring
COVER PLATE PARTS		
505	1	Gasket
507	4	Screw
508	1	Cover Plate

Note 1. Qty is 0, 1, 2 or 3 dependent on Valve Plate type.

THRU-SHAFT COUPLINGS

CODE "D" ASSEMBLY (TOP VIEW)
SHOWING L51447-008 COUPLING

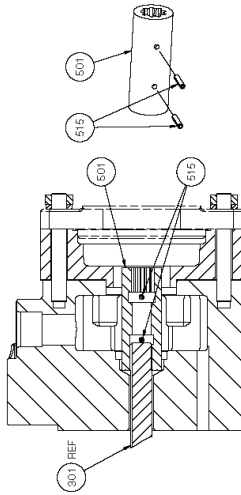

CODE "T" ASSEMBLY (SIDE VIEW)
SHOWING L51447-008 COUPLING

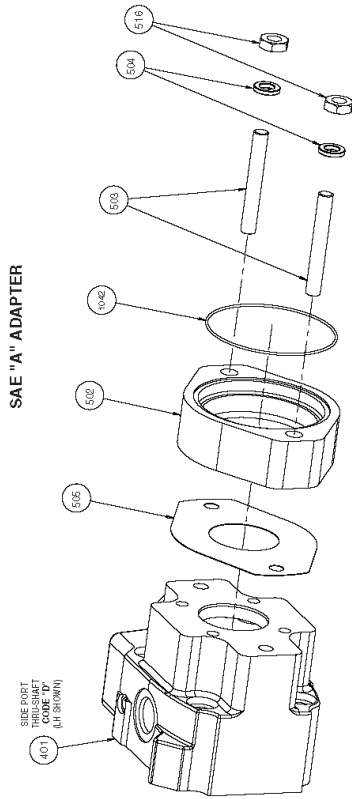
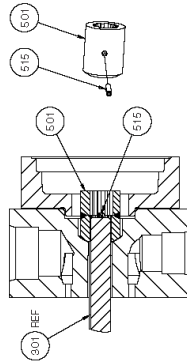

OILG0298

Figure 12. Exploded parts drawing, PVWJ-011/-014/-022 A-Frame, Thru-Shaft Couplings and SAE "A" Adapter (520024-101 sheet 3 of 4).

Item	Qty.	Description
DRIVE SHAFT ASSEMBLY GROUP		
301	1	Drive Shaft
VALVE PLATE ASSEMBLY GROUP		
401	1	Valve Plate

DUAL PUMP ADAPTER PARTS		
501	1	Coupling
502	1	Adapter
503	2	Stud
504	2	Washer
505	1	Gasket
515	1	Roll Pin
516	2	Hex Nut
1042	1	O-Ring

Document Number: 520024-SK1
 Revision: New

Reference 520024-101
 SERVICE KIT Drawings figures 10-12

SERVICE KITS
 PVWJ A-Frame Units (PVWJ-011/-014/-022)

Description	Kit No.	Design Series	Items Included (quantity is 1 unless noted)
Housing Kits			
All Models	L51116-30	A1	001, 005(4), 007, 012, 1010(2), 1145, 1500
Rotating Group Bearing Kit			
All Models	L51203-1	A1	202, 208
Shaft & Bearing Kits			
Kits for Non Thru-Shaft Models			
3/4" Dia. Keyed (Code "Y")	L51128-11	A1	301, 302, 303, 304, 305, 306
7/8" Dia. Keyed (Code "B")	L51128-15	A1	301, 302, 303, 304, 305, 306
5/8" 9T SAE Spline (Code "S")	L51128-13	A1	301, 302, 304, 305, 306
7/8" 13T Industrial Spline (Code "C")	L51128-17	A1	301, 302, 304, 305, 306
Kits for Thru-Shaft Models with Code "DA" Valve Plates			
3/4" Dia. Keyed (Code "Y")	L51518-11A	A1	301, 302, 303, 304, 305, 306
7/8" Dia. Keyed (Code "B")	L51518-11	A1	301, 302, 303, 304, 305, 306
5/8" 9T SAE Spline (Code "S")	L51518-10	A1	301, 302, 304, 305, 306
5/8" 9T Industrial Spline (Code "D")	L51518-12Z	A1	301, 302, 304, 305, 306
7/8" 13T Industrial Spline (Code "C")	L51518-12	A1	301, 302, 304, 305, 306
Kits for Thru-Shaft Models with Code "TA" Valve Plates			
3/4" Dia. Keyed (Code "Y")	L51518-33A	A1	301, 302, 303, 304, 305, 306
7/8" Dia. Keyed (Code "B")	L51518-39A	A1	301, 302, 303, 304, 305, 306
5/8" 9T SAE Spline (Code "S")	L51518-35A	A1	301, 302, 304, 305, 306
5/8" 9T Industrial Spline (Code "D")	L51518-37A	A1	301, 302, 304, 305, 306
7/8" 13T Industrial Spline (Code "C")	L51518-57	A1	301, 302, 304, 305, 306
Swashblock Kits			
LH (CW) Models	L50488-3	A1	201, 721
RH (CW) Models	L50488-5	A1	201, 721
Rotating Group Kits			
PVWJ-011	L50052-8	A1	101, 102(7), 103, 104, 105
PVWJ-014	L50052-7	A1	101, 102(7), 103, 104, 105
PVWJ-022	L50053-7	A1	101, 102(7), 103, 104, 105
Saddle Bearing Kit			
All Models	L51053-4	A1	204A, 204B

Valve Plate Kits			
PVWJ-011			
LH Rear Port (Code "SA")	K51101-500	A1	401, 403(4), 601(2), 1010, 1500, 1902(2)
RH Rear Port (Code "SA")	K51101-501	A1	401, 403(4), 601(2), 1010, 1500, 1902(2)
LH Side Port, Non Thru-Shaft (Code "GA")	K51101-502	A1	401, 403(4), 650(2), 1010, 1500
RH Side Port, Non Thru-Shaft (Code "GA")	K51101-503	A1	401, 403(4), 650(2), 1010, 1500
LH Side Port, Thru-Shaft (Code "DA")	K51101-504	A1	401, 403(4), 601(2), 626(3), 1010, 1500, 1902(2), 1910(3)
RH Side Port, Thru-Shaft (Code "DA")	K51101-505	A1	401, 403(4), 601(2), 626(3), 1010, 1500, 1902(2), 1910(3)
LH Top/Bottom Port, Thru-Shaft (Code "TA")	K51101-506	A1	401, 403(4), 650(2), 1010, 1500
RH Top/Bottom Port, Thru-Shaft (Code "TA")	K51101-507	A1	401, 403(4), 650(2), 1010, 1500
PVWJ-014			
LH Rear Port (Code "SA")	K51101-508	A1	401, 403(4), 601(2), 1010, 1500, 1902(2)
RH Rear Port (Code "SA")	K51101-509	A1	401, 403(4), 601(2), 1010, 1500, 1902(2)
LH Side Port, Non Thru-Shaft (Code "GA")	K51101-510	A1	401, 403(4), 650(2), 1010, 1500
RH Side Port, Non Thru-Shaft (Code "GA")	K51101-511	A1	401, 403(4), 650(2), 1010, 1500
LH Side Port, Thru-Shaft (Code "DA")	K51101-512	A1	401, 403(4), 601(2), 626(3), 1010, 1500, 1902(2), 1910(3)
RH Side Port, Thru-Shaft (Code "DA")	K51101-513	A1	401, 403(4), 601(2), 626(3), 1010, 1500, 1902(2), 1910(3)
LH Top/Bottom Port, Thru-Shaft (Code "TA")	K51101-514	A1	401, 403(4), 650(2), 1010, 1500
RH Top/Bottom Port, Thru-Shaft (Code "TA")	K51101-515	A1	401, 403(4), 650(2), 1010, 1500
PVWJ-022			
LH Rear Port (Code "SA")	K51101-516	A1	401, 403(4), 601(2), 1010, 1500, 1902(2)
RH Rear Port (Code "SA")	K51101-517	A1	401, 403(4), 601(2), 1010, 1500, 1902(2)
LH Side Port, Non Thru-Shaft (Code "GA")	K51101-518	A1	401, 403(4), 650(2), 1010, 1500
RH Side Port, Non Thru-Shaft (Code "GA")	K51101-519	A1	401, 403(4), 650(2), 1010, 1500
LH Side Port, Thru-Shaft (Code "DA")	K51101-520	A1	401, 403(4), 601(2), 626(3), 1010, 1500, 1902(2), 1910(2)
RH Side Port, Thru-Shaft (Code "DA")	K51101-521	A1	401, 403(4), 601(2), 626(3), 1010, 1500, 1902(2), 1910(3)
LH Top/Bottom Port, Thru-Shaft (Code "TA")	K51101-522	A1	401, 403(4), 650(2), 1010, 1500
RH Top/Bottom Port, Thru-Shaft (Code "TA")	K51101-523	A1	401, 403(4), 650(2), 1010, 1500
Pump Seal Kit			
All models	L50824-24	A1	007, 1010(2), 1138, 1145, 1500, 1902(3), 1910(3)
Piston & Shoe Kits			
PVWJ-011	L51363-900	A1	102(7)
PVWJ-014	L50021-900	A1	102(7)
PVWJ-022	L50021-901	A1	102(7)
Shoe Retainer & Holddown Ball Kit			
All models	L50019	A1	103, 104
Tag Kit			
All models	L50921	A1	003, 008(2)

Control Pin					
All models	50623-5	A1	721		
Cover Plate Kit					
All models	L50671	A1	505, 507(4), 508		
Coupling & A dapter Kits					
All models using code "DA" Valve Plate	L51081-48	A1	501, 502, 503(2), 504(2), 505, 506, 515(2), 516(2)		
All models using code "TA" Valve Plate	L51081-113	A1	501, 502, 503(2), 504(2), 505, 506, 515, 516(2)		

PVWJ-025/-034/-046 B-Frame

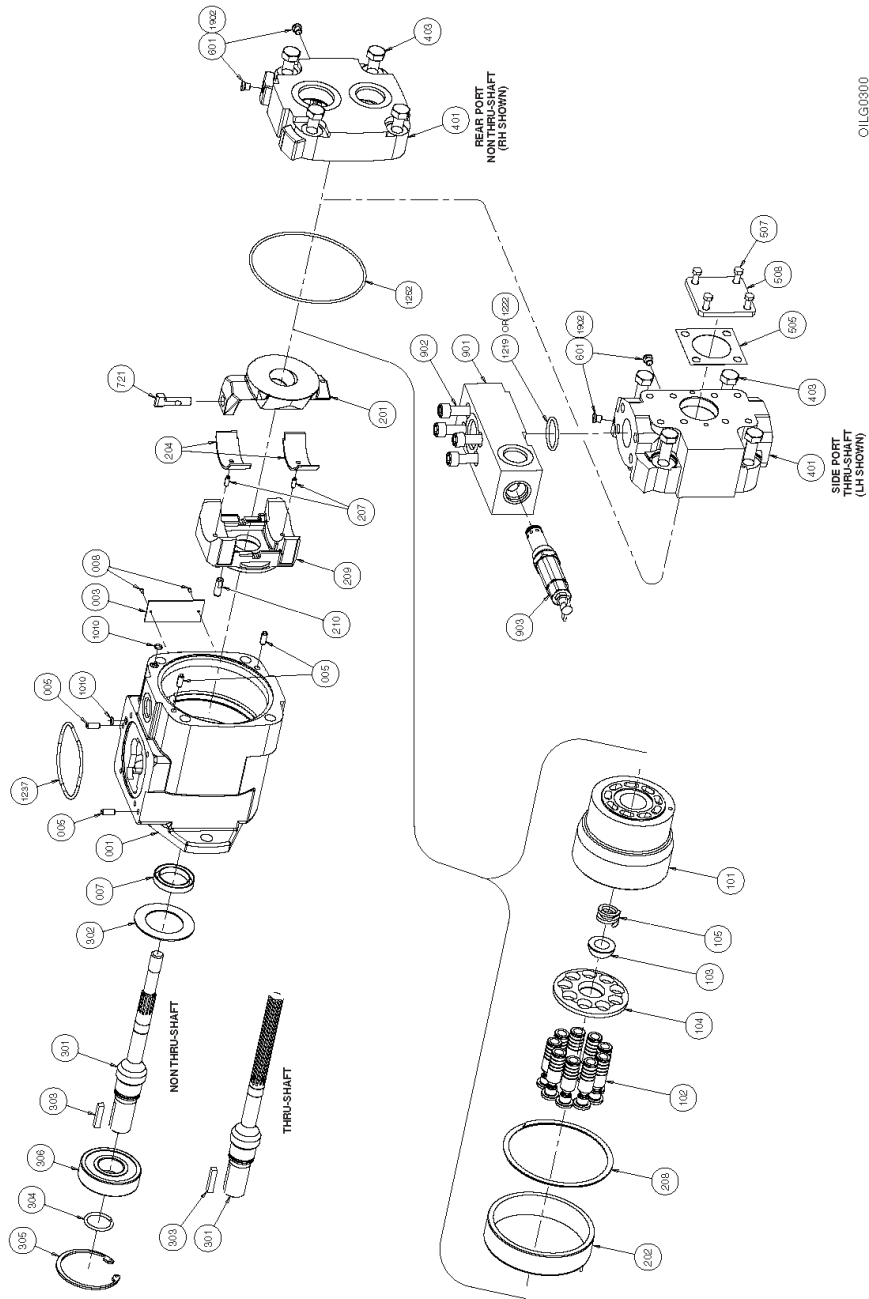

Figure 13. Exploded parts drawing, PVWJ-025/-034/-046 B-Frame (520024-201 sheet 2 of 4).

OILG0000

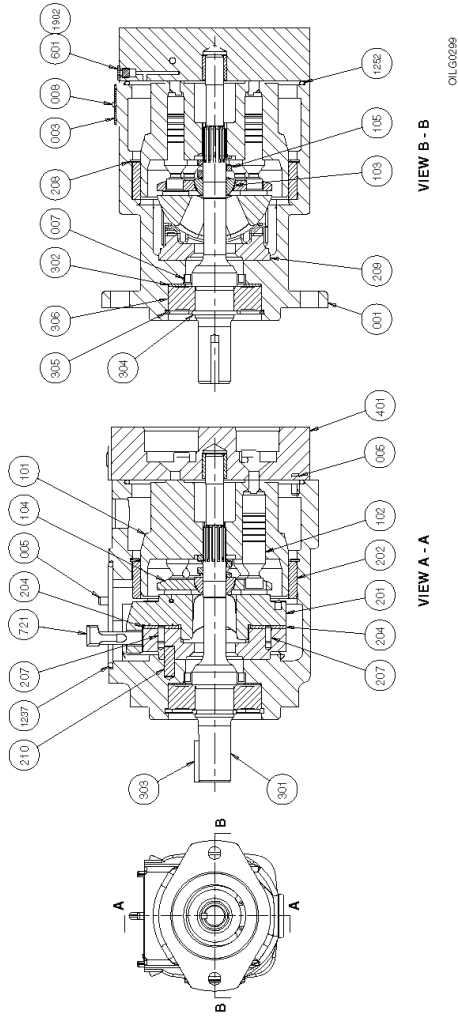

Figure 14. Cross section and plan view parts drawing, PVWJ-025/-034/-046 B-Frame (520024-201 sheet 1 of 4).

PVWJ-025/-034/-046 B-FRAME PUMP PARTS LIST

Item	Qty.	Description
HOUSING ASSEMBLY GROUP		
001	1	Pump Housing
003	1	Name Tag
005	4	Roll Pin
007	1	Shaft Seal
008	2	Drive Screws
1010	2	O-Ring
1237	1	O-Ring
1252	1	O-Ring
ROTARY ASSEMBLY GROUP		
101	1	Barrel
102	9	Piston & Shoe Assembly
103	1	Fulcrum Ball
104	1	Shoe Retainer
105	1	Shoe Retainer Spring

SWASHBLOCK ASSEMBLY GROUP		
201	1	Swashblock
202	1	Hydrodynamic Bearing
204	2	Saddle Bearing
207	2	Saddle Bearing Locating Pin
208	1	Retaining Ring
209	1	Saddle Block
210	1	Saddle Block Locating Ring
721	1	Control Pin
DRIVE SHAFT ASSEMBLY GROUP		
301	1	Drive Shaft
302	1	Seal Retainer
303	1	Key
304	1	Shaft Retainer Ring
305	1	Shaft Bearing Retainer Ring
306	1	Front Drive Shaft Bearing
VALVE PLATE ASSEMBLY GROUP		
401	1	Valve Plate
403	4	Screw
601	2	Plug
1902	2	O-Ring

COVER PLATE PARTS		
505	1	Gasket
507	4	Screw
508	1	Cover Plate
RELIEF VALVE ASSEMBLY GROUP-OPTIONAL		
901	1	Block
902	1	Screw
903	1	Relief Valve Cartridge
1219	1	O-Ring (PVWJ-025)
1222	1	O-Ring (PVWJ-034/-046)

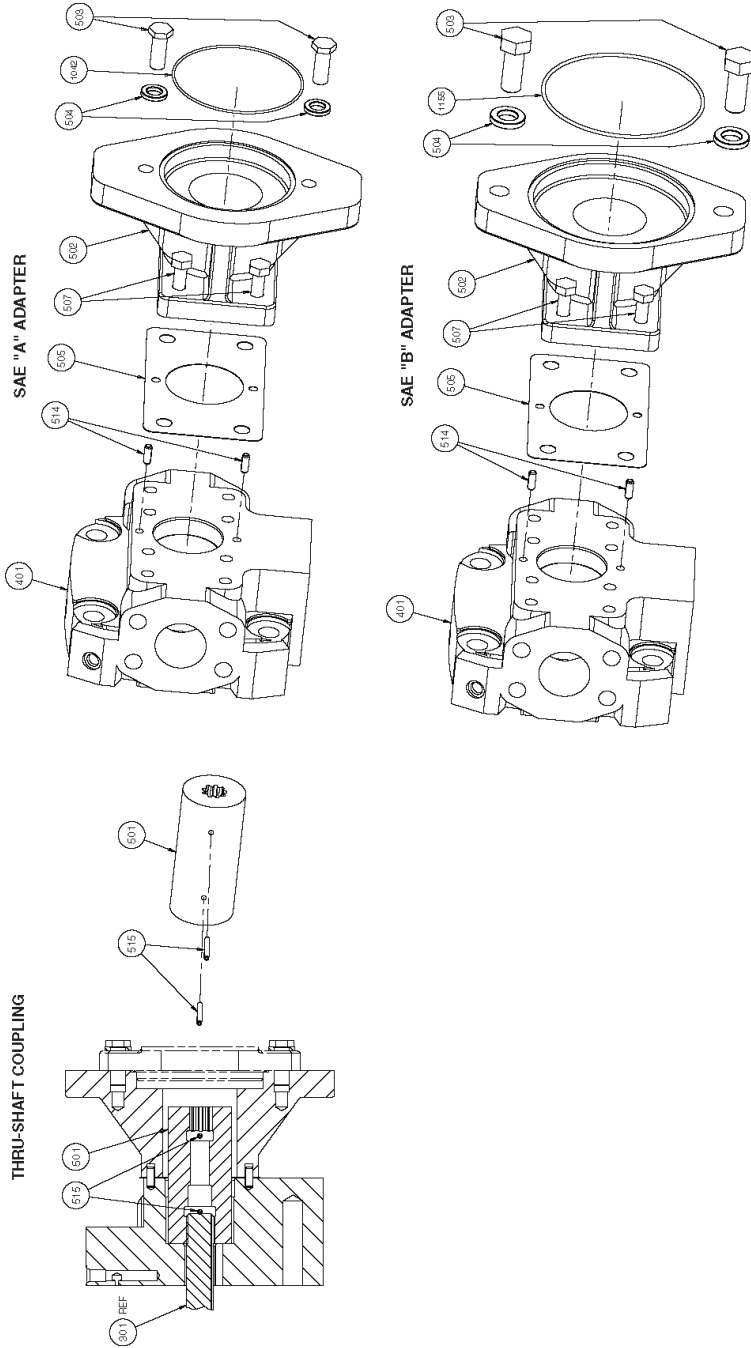

OILG0301

Figure 15. Exploded parts drawing, PVWJ-025/-034/-046 B-Frame, Thru-Shaft Coupling, SAE "A" and SAE "B" Adapter (520024-201 sheet 3 of 4).

Item	Qty.	Description
DRIVE SHAFT ASSEMBLY GROUP		
301	1	Drive Shaft
VALVE PLATE ASSEMBLY GROUP		
401	1	Valve Plate

DUAL PUMP ADAPTER PARTS		
501	1	Coupling
502	1	Adapter
503	2	Screw
504	2	Washer
505	1	Gasket

507	4	Screw
514	1	Roll Pin
515	1	Roll Pin
1042	1	O-Ring
1155	1	O-Ring

Document Number: 520024-SK2
Revision: New

Reference 520024-201
SERVICE KIT Drawings figures 13-15

SERVICE KITS
PVWJ B-Frame Units (PVWJ-025/-034/-046)

Description	Kit No.	Design Series	Items Included (quantity is 1 unless noted)
Housing Kits			
All Models	K51121-101	A1	001, 005(4), 007, 1010(2), 1237, 1252
Rotating Group Bearing Kit			
All Models	L51065-1	A1	202, 208
Shaft & Bearing Kits			
PVWJ-025/-034/-046			
7/8" Dia. Keyed (Code Y)	L51129-11	A1	301, 302, 303, 304, 305, 306
1" Dia. Keyed (Code B)	L51129-15	A1	301, 302, 303, 304, 305, 306
7/8" 13T Spline (Code S)	L51129-13	A1	301, 302, 304, 305, 306
1" 15T Spline (Code C)	L51129-17	A1	301, 302, 304, 305, 306
7/8" 13T Spline (Code D) (Industrial)	L51129-39Z	A1	301, 302, 304, 305, 306
7/8" Dia. Keyed (Code Y)	L51519-11A	A1	301, 302, 303, 304, 305, 306
1" Dia. Keyed (Code B)	L51519-11	A1	301, 302, 303, 304, 305, 306
7/8" 13T Spline (Code S)(SAE)	L51519-10	A1	301, 302, 304, 305, 306
7/8" 13T Spline (Code D) (Industrial)	L51519-12Z	A1	301, 302, 304, 305, 306
Swashblock Kits			
LH (CCW) Models	L50480-1	A1	201, 721
RH (CW) Models	L50480-2	A1	201, 721
Saddle Bearing Kit			
All models	L51053-5	A1	204(2)
Rotating Group Kits			
PVWJ-025	L50167-10	A1	101, 102(9), 103, 104, 105
PVWJ-034	L50167-7	A1	101, 102(9), 103, 104, 105
PVWJ-046	L50168-7	A1	101, 102(9), 103, 104, 105

PVWJ-064/-076/-098/-130 B-Frame

Saddle Kit									
All models		L51052-7	A1					204(2), 207(2), 209	
Valve Plate Kits									
PVWJ-025									
LH Rear Port (Code "SA")		K51102-201	A1					401, 403(4), 601(2), 1010, 1252, 1902(2)	
RH Rear Port (Code "SA")		K51102-202	A1					401, 403(4), 601(2), 1010, 1252, 1902(2)	
LH Side Port, Thru-Shaft (Code "DF" & "DR")		K51102-203	A1					401, 403(4), 601(2), 1010, 1252, 1902(2)	
RH Side Port, Thru-Shaft (Code "DF" & "DR")		K51102-204	A1					401, 403(4), 601(2), 1010, 1252, 1902(2)	
PVWJ-034									
LH Rear Port (Code "SA")		K51102-205	A1					401, 403(4), 601(2), 1010, 1252, 1902(2)	
RH Rear Port (Code "SA")		K51102-206	A1					401, 403(4), 601(2), 1010, 1252, 1902(2)	
LH Side Port, Thru-Shaft (Code "DF" & "DR")		K51102-207	A1					401, 403(4), 601(2), 1010, 1252, 1902(2)	
RH Side Port, Thru-Shaft (Code "DF" & "DR")		K51102-208	A1					401, 403(4), 601(2), 1010, 1252, 1902(2)	
PVWJ-046									
LH Rear Port (Code "SA")		K51102-209	A1					401, 403(4), 601(2), 1010, 1252, 1902(2)	
RH Rear Port (Code "SA")		K51102-210	A1					401, 403(4), 601(2), 1010, 1252, 1902(2)	
LH Side Port, Thru-Shaft (Code "DF" & "DR")		K51102-211	A1					401, 403(4), 601(2), 1010, 1252, 1902(2)	
RH Side Port, Thru-Shaft (Code "DF" & "DR")		K51102-212	A1					401, 403(4), 601(2), 1010, 1252, 1902(2)	
Pump Seal Kit									
All models		K50825-200	A1					007, 1010(2), 1237, 1252, 1902(2)	
Piston & Shoe Kits									
PVWJ-025		L51349-900	A1					102(9)	
PVWJ-034		L50146-900	A1					102(9)	
PVWJ-046		L50175-900	A1					102(9)	
Shoe Retainer & Holddown Ball Kit									
All models		L50132	A1					103, 104	
Tag Kit									
All models		L50921	A1					003, 008(2)	
Control Pin									
All models		51339-5	A1					721	
Cover Plate Kit									
All models		L50671	A1					505, 507(4), 508	
Coupling & Adapter Kits									
SAE A Adapter		L51081-53	A1					501, 502, 503(2), 504(2), 505, 507(4), 514(2), 515(2), 1042	
SAE B Adapter		L51081-43	A1					501, 502, 503(2), 504(2), 505, 507(4), 514(2), 515(2), 1155	

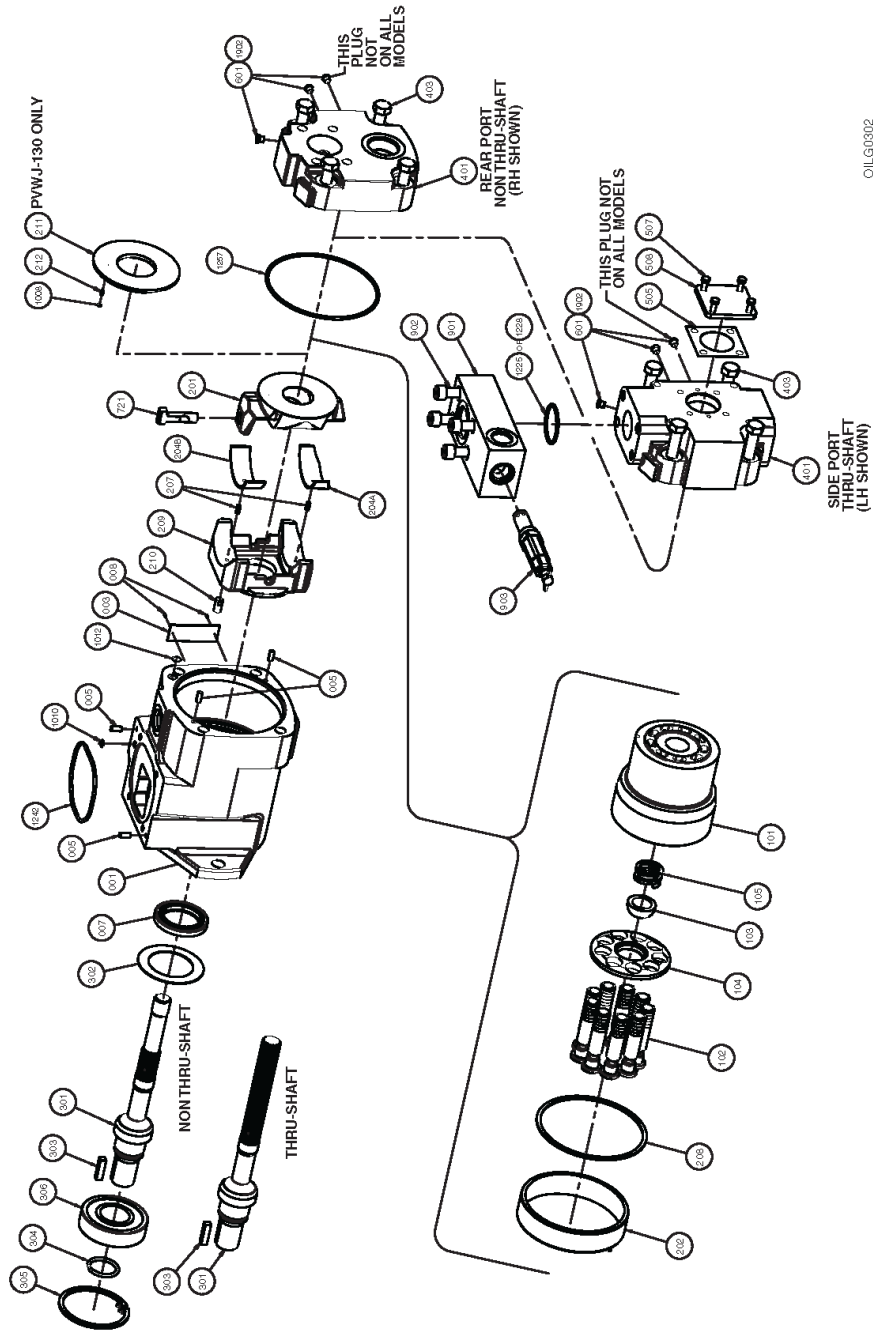
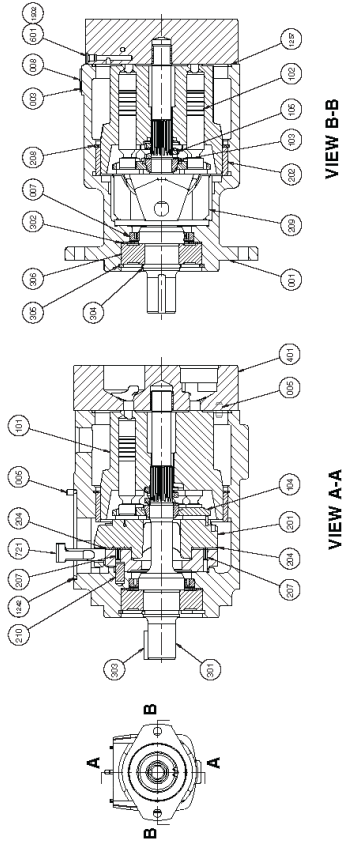

Figure 16. Exploded parts drawing, PVWJ-064/-076/-098/-130 C-Frame (520024-301 sheet 2 of 4).

OILG0002



OILG0003

Figure 17. Cross section and plan view parts drawing, -064/-076/-098/-130 C-Frame (520024-301 sheet 1 of 4).

PVWJ-064-076/-098/-130 C-FRAME PUMP PARTS LIST

Item	Qty.	Description
HOUSING ASSEMBLY GROUP		
001	1	Pump Housing
003	1	Name Tag
005	4	Roll Pin
007	1	Shaft Seal
008	2	Drive Screws
1010	1	O-Ring
1012	1	O-Ring
1242	1	O-Ring
1257	1	O-Ring
ROTARY ASSEMBLY GROUP		
101	1	Barrel
102	9	Piston & Shoe Assembly
103	1	Fulcrum Ball
104	1	Shoe Retainer
105	1	Shoe Retainer Spring

SWASHBLOCK ASSEMBLY GROUP		
201	1	Swashblock
202	1	Hydrodynamic Bearing
204A	1	Saddle Bearing (PVWJ-064)
204B	1 or 2	Saddle Bearing (PVWJ-064/-076/-098)
204C	2	Saddle Bearing (PVWJ-130)
207	2	Saddle Bearing Locating Pin
208	1	Retaining Ring
209	1	Saddle Block
210	1	Saddle Block Locating Ring
211	1	Wear Plate (PVWJ-130 only)
212	1	Wear Plate Locating Pin (PVWJ-130 only)
721	1	Control Pin
1008	1	O-Ring (PVWJ-130 only)
DRIVE SHAFT ASSEMBLY GROUP		
301	1	Drive Shaft
302	1	Seal Retainer
303	1	Key
304	1	Shaft Retainer Ring
305	1	Shaft Bearing Retainer Ring
306	1	Front Drive Shaft Bearing

VALVE PLATE ASSEMBLY GROUP		
401	1	Valve Plate
403	4	Screw
601	2 or 3	Plug
1902	2 or 3	O-Ring
COVER PLATE PARTS		
505	1	Gasket
507	4	Screw
508	1	Cover Plate
RELIEF VALVE ASSEMBLY GROUP-OPTIONAL		
901	1	Block
902	1	Screw
903	1	Relief Valve Cartridge
1225	1	O-Ring (PVWJ-064)
1228	1	O-Ring (PVWJ-076/-098/-130)

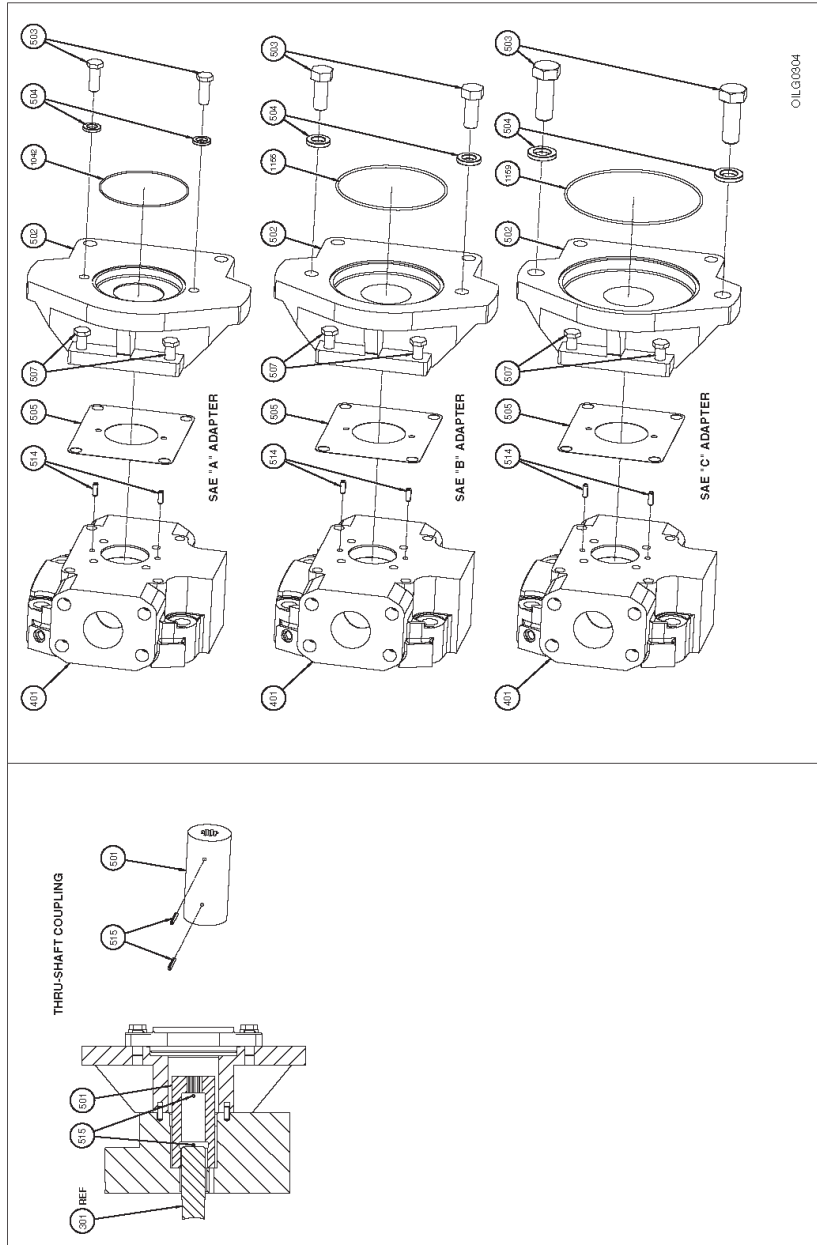

Figure 18. Exploded parts drawing, PVWJ-064/-076/-098/-130 C-Frame, Thru-Shaft Coupling, SAE "A", SAE "B" and SAE "C" Adapter (520024-301 sheet 3 of 4).

Item	Qty.	Description
DRIVE SHAFT ASSEMBLY GROUP		
301	1	Drive Shaft
VALVE PLATE ASSEMBLY GROUP		
401	1	Valve Plate

DUAL PUMP ADAPTER		
501	1	Coupling
502	1	Adapter
503	2	Screw
504	2	Washer
505	1	Gasket

507	4	Screw
514	2	Roll Pin
515	2	Roll Pin
1042	1	O-Ring
1155	1	O-Ring
1159	1	O-Ring

Reference 520024-301
 SERVICE KIT Drawings figures 16-18
 Document Number: 520024-SK3
 Revision: New

SERVICE KITS
 PVWJ C-Frame Units
 (PVWJ-064/-076/-098/-130)

Description	Kit No.	Design Series	Items Included (quantity is 1 unless noted)
Housing Kits			
All Models	KS1114-101	A1	001, 005(4), 007, 1010(2), 1242, 1257
Rotating Group Bearing Kit			
All Models	L51066-1	A1	202, 208
Shaft & Bearing Kits			
1 1/4" Dia. Keyed (Code Y) Standard	L51130-11	A1	301, 302, 303, 304, 305, 306
1 1/4" 14T Spline (Code S) Standard (SAE)	L51130-13	A1	301, 302, 304, 305, 306
1 1/4" 14T Spline (Code D) Standard (Industrial)	L51130-13Z	A1	301, 302, 304, 305, 306
1 1/4" Dia. Keyed (Code Y) T-S	L51520-11	A1	301, 302, 303, 304, 305, 306
1 1/4" 14T Spline (Code S) T-S (SAE)	L51520-10	A1	301, 302, 304, 305, 306
1 1/4" 14T Spline (Code D) T-S (Industrial)	L51520-12Z	A1	301, 302, 304, 305, 306
Swashblock Kits			
PVWJ-064/-076/-098 LH (CW) Models	L50481-3	A1	201, 721
PVWJ-064/-076/-098 RH (CW) Models	L50481-5	A1	201, 721
PVWJ-130 LH (CCW) Models	L50481-4	A1	201, 211, 212, 213, 721
PVWJ-130 RH (CW) Models	L50481-6	A1	201, 211, 212, 213, 721
Saddle Bearing Kits			
PVWJ-064	L51053-8	A1	204A, 204B
PVWJ-076 & -098	L51053-6	A1	204B(2)
PVWJ-130	L51053-7	A1	204C(2)
Rotating Group Kits			
PVWJ-064	L50108-11	A1	101, 102(9), 103, 104, 105
PVWJ-076	L50087-7	A1	101, 102(9), 103, 104, 105
PVWJ-098	L50108-7	A1	101, 102(9), 103, 104, 105
PVWJ-130	L50108-8	A1	101, 102(9), 103, 104, 105
Saddle Kits			
PVWJ-064	L51052-13	A1	204A, 204B, 207(2), 209
PVWJ-076 & -098	L51052-8	A1	204B(2), 207(2), 209
PVWJ-130	L51052-9	A1	204C(2), 207(2), 209

Valve Plate Kits					
PVWJ-064					
LH Rear Port (Code "SA")	K51103-213	A1		401, 403(4), 405(2), 408(2), 1012, 1257	
RH Rear Port (Code "SA")	K51103-214	A1		401, 403(4), 405(3), 408(3), 1012, 1257	
LH Side Port, Thru Shaft (Code "DF" & "DR")	K51103-215	A1		401, 403(4), 405(2), 408(2), 1012, 1257	
RH Side Port, Thru Shaft (Code "DF" & "DR")	K51103-216	A1		401, 403(4), 405(3), 408(3), 1012, 1257	
PVWJ-076					
LH Rear Port (Code "SA")	K51103-201	A1		401, 403(4), 405(2), 408(2), 1012, 1257	
RH Rear Port (Code "SA")	K51103-202	A1		401, 403(4), 405(3), 408(3), 1012, 1257	
LH Side Port, Thru Shaft (Code "DF" & "DR")	K51103-207	A1		401, 403(4), 405(2), 408(2), 1012, 1257	
RH Side Port, Thru Shaft (Code "DF" & "DR")	K51103-208	A1		401, 403(4), 405(3), 408(3), 1012, 1257	
PVWJ-098					
LH Rear Port (Code "SA")	K51103-203	A1		401, 403(4), 405(2), 408(2), 1012, 1257	
RH Rear Port (Code "SA")	K51103-204	A1		401, 403(4), 405(3), 408(3), 1012, 1257	
LH Side Port, Thru Shaft (Code "DF" & "DR")	K51103-209	A1		401, 403(4), 405(2), 408(2), 1012, 1257	
RH Side Port, Thru Shaft (Code "DF" & "DR")	K51103-210	A1		401, 403(4), 405(3), 408(3), 1012, 1257	
PVWJ-130					
LH Rear Port (Code "SA")	K51103-205	A1		401, 403(4), 405(2), 408(2), 1012, 1257	
RH Rear Port (Code "SA")	K51103-206	A1		401, 403(4), 405(3), 408(3), 1012, 1257	
LH Side Port, Thru Shaft (Code "DF" & "DR")	K51103-211	A1		401, 403(4), 405(2), 408(2), 1012, 1257	
RH Side Port, Thru Shaft (Code "DF" & "DR")	K51103-212	A1		401, 403(4), 405(3), 408(3), 1012, 1257	
Pump Seal Kit					
All models	K50826-200	A1		007, 1008, 1010, 1012, 1242, 1257, 1902(9)	
Piston & Shoe Kits					
PVWJ-064	L51109-900	A1		102(9)	
PVWJ-076	L51107-900	A1		102(9)	
PVWJ-098	L51109-901	A1		102(9)	
PVWJ-130	L51303-900	A1		102(9)	
Shoe Retainer & Holddown Ball Kits					
PVWJ-064/-076/-098	L50071	A1		103, 104	
PVWJ-130	L51305-2	A1		103, 104	
Tag Kit					
All models	L50921	A1		003, 008(2)	
Control Pin					
All models	51339-2	A1		721	

Cover Plate Kit			
All models	L50671	A1	505, 507(4), 508
Coupling & Adapter Kits			
SAE A Adapter	L51081-52	A1	501, 502, 503(2), 504(2), 505, 507(4), 514(2), 515(2), 1042
SAE B Adapter	L51081-51	A1	501, 502, 503(2), 504(2), 505, 507(4), 514(2), 515(2), 1155
SAE C Adapter	L51081-49	A1	501, 502, 503(2), 504(2), 505, 507(4), 514(2), 1159

AFTER SALES SERVICES

At Oilgear we build products to last. It is the nature of this type of machinery to require proper maintenance regardless of the care we put into manufacturing. Oilgear has several service programs in place to help you.

STAY-ON-STREAM SERVICE

By signing up for Oilgear's Stay-On-Stream program, you can prepare for problems before they happen. Certain field tests such as fluid testing, slip testing and electronic profile recording comparisons can be performed by our field service people or your own factory trained personnel. These tests can indicate problems before they become "down-time" difficulties.

SERVICE SCHOOLS

Oilgear conducts training to train your maintenance personnel. "General" hydraulic or electronic training is conducted at our Milwaukee, Wisconsin plant on a regular basis. "Custom" training, specifically addressing your particular hydraulic and electro-hydraulic equipment, can be conducted at your facilities.

SPARE PARTS AVAILABILITY

Prepare for your future needs by stocking Oilgear original factory parts. Having the correct parts and necessary skills "in-plant" enables you to minimize "down-time." Oilgear has developed parts kits to cover likely future needs. Oilgear Field Service Technicians are also ready to assist you and your maintenance people in troubleshooting and repairing equipment.



**SERVICE INSTRUCTIONS
 “PVWJ” A-FRAME PUMPS -011/-014/-022
 FOR TYPE “P-1NN” AND “P-LNN”
 PRESSURE COMPENSATING CONTROLS**

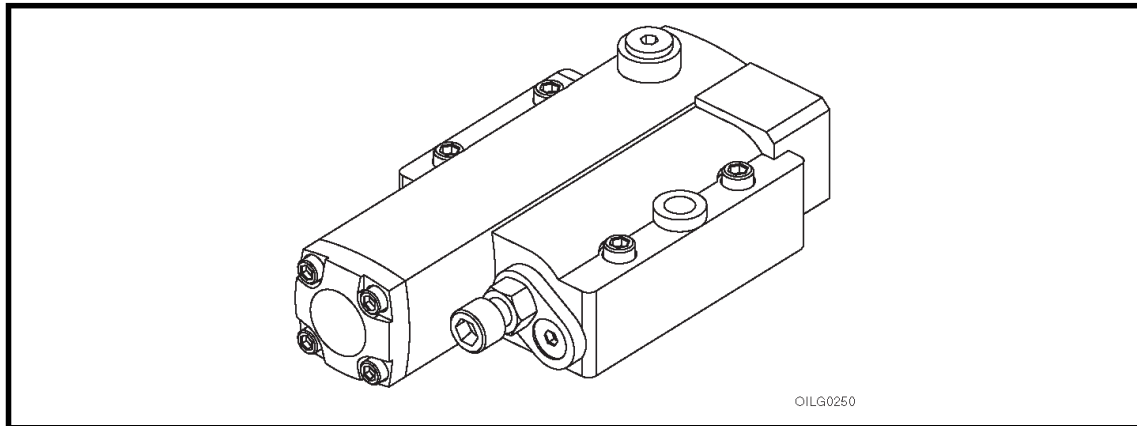

Figure 1. Typical Oilgear Type “P-1NN” and “P-LNN” Pressure Compensator Controls for “PVWJ” A-Frame Pump

PURPOSE OF INSTRUCTIONS

These instructions will simplify the installation, operation and maintenance of Oilgear type “P-1NN” and “P-LNN” controlled units.

This material will inform you about the basic construction, principle of operation and service parts listings. Some controls may be modified for specific applications from those described in this bulletin and other changes may be made without notice.

GENERAL REFERENCE MATERIAL

Fluid Recommendations	Bulletin 90000
Contamination Evaluation Guide	Bulletin 90004
Filtration Recommendations	Bulletin 90007
Piping Information	Bulletin 90011
Proper Installation of Vertical Pumps	Bulletin 90014
PVWJ Open Loop Pumps, Application Guidelines	Bulletin 847085
PVWJ Open Loop Pumps (All Frame Sizes) Service Instructions	Bulletin 947085
PVWJ Open Loop Pumps, Sales	Bulletin 47085

PVWJ PUMP INSTALLATIONS

PVWJ A Frame (PVWJ-011/-014/-022) w/ Rear Ports	DS-47480
PVWJ A Frame (PVWJ-011/-014/-022) w/ Side Ports	DS-47481
PVWJ A Frame (PVWJ-011/-014/-022) w/ Side Ports & Thru Shaft	DS-47482

PVWJ PUMP CONTROL INSTALLATIONS

“P-1NN” and “P-LNN” Pressure Compensator for PVWJ-011/-014/-022	DS-47984
---	----------

THE OILGEAR COMPANY
 2300 South 51st Street
 Milwaukee, Wisconsin 53219
 www.oilgear.com

Safety First

Read and understand this entire instruction sheet before repairing, or adjusting your Oilgear product.

Those who use and maintain this equipment must be thoroughly trained and familiar with the product. If incorrectly used or maintained, this product and its equipment can cause severe injury.

SAFETY SYMBOLS

The following signal words are used in this instruction sheet to identify areas of concern where your safety may be involved. Carefully read the text and observe any instructions provided to ensure your safety.

DANGER

THIS SIGNAL WORD INDICATES AN IMMEDIATELY HAZARDOUS SITUATION WHICH, IF NOT AVOIDED, WILL RESULT IN DEATH OR SERIOUS INJURY.

WARNING

This signal word indicates a potentially hazardous situation which, if not avoided, could result in death or serious injury.

CAUTION

This signal word indicates that a potentially hazardous situation exists which, if not avoided, may result in damage to equipment or minor personal injury.

NOTE

While not directly relevant to the topic being discussed, the NOTE is used to emphasize information provided, or provide additional information which may be of benefit.

WARNING

This service information is designed for the maintenance of your Oilgear product. It contains the information on the correct procedures determined by Oilgear for the safe manner of servicing. Always keep this instruction sheet in a location where it is readily available for the persons who use and maintain the product. Additional copies of this instruction sheet are available through the Oilgear Company. Contact us at 414-327-1700 or visit our website: www.oilgear.com. Please contact us if you have any questions regarding the information in this instruction bulletin.

NOTE

The cleanliness of working on this pump control or the hydraulic system is extremely important to the safety and reliability of the pump and the system. Always make sure the fittings are clean on the outside before removing them from their connections, are capped and plugged when removed and placed in a clean rag or container until they are reinstalled.

WARNING

Some service operations may require special tools or equipment. If you require information on these items, please contact Oilgear before attempting these repairs and service operations.

WARNING

Read, understand and follow the safety guidelines, dangers and warnings contained in this instruction sheet to promote reliable operation and prevent serious personal injury.

WARNING

DO NOT attempt to service this machinery in an environment where safety regulations are not established and in place.

WARNING

DO NOT operate the hydraulic system if a leak is present. Serious injury may result.

WARNING

Hydraulic systems operate under very high pressure. Hydraulic fluid escaping from a pressurized system can penetrate unprotected body tissue. DO NOT inspect for hydraulic leaks with bare hands or other exposed body parts. As a minimum, wear leather gloves prior to inspecting for leaks and use cardboard or wood. If leaks are present, relieve pressure and allow system to cool prior to servicing. If injured by escaping hydraulic oil, contact a physician immediately. Serious complications may arise if not treated immediately. If you have questions regarding inspecting for hydraulic leaks, please contact Oilgear prior to servicing.

⚠ WARNING

Hydraulic hoses and tubing must be inspected on a daily basis for leaks, cuts, abrasions, damage and improper clearance along any mounting frame for hidden damage before the unit is put into service. Replace damaged hoses or hoses you suspect are damaged before the system is returned to service! Hoses must be replaced every two years. Failure to properly inspect and maintain the system may result in serious injury.

⚠ WARNING

Hydraulic systems are hot. DO NOT TOUCH! Serious personal injury may result from hot oil. When you have completed working on the hydraulic system, thoroughly clean any spilled oil from the equipment. Do not spill any hydraulic fluids on the ground. Clean any hydraulic fluids from your skin as soon as you have completed maintenance and repairs. Dispose of used oil and system filters as required by law.

⚠ WARNING

Use correct hoses, fittings, and adapters with the correct SAE rating when replacing hoses to prevent possible serious injury. Always replace hoses, fittings and adapters with replacements that have a proper, suitable, working pressure rating. Replacement hoses must be of the correct length and must comply with the hose manufacturer's and Oilgear's installation guidelines and recommendations.

⚠ WARNING

Hydraulic hoses have the SAE ratings marked on the hose to assist you in selecting the correct hose. The same manufacturer must supply any replacement hydraulic hoses and fitting assemblies. As an example: Brand "X" hose and brand "Y" fitting will not normally be compatible. No "Twist" is allowed in the hydraulic hoses. "Twist" may result in premature hose failure. This can cause serious injury. Please contact Oilgear for assistance when required.

⚠ WARNING

Hydraulic cylinders can be holding a function in a certain position when the pump is OFF. An example of this is a function being held in the lift or partial lift position by the cylinders. If a hydraulic line is removed or the hydraulic circuits or controls are being worked on, gravity may allow the function being held in position to drop. All workers and personnel must remain clear of these areas when working on or operating the hydraulic system. Block and secure all devices and functions which apply before beginning work or operation. Failure to comply with this can result in serious injury or death.

⚠ WARNING

Any hydraulic pipe which is replaced must conform to SAE J1065 specifications. If incorrect hydraulic pipe is installed, the hydraulic system may fail, causing serious injury. Damaged or leaking fittings, pipes or hoses must be replaced before the system is returned to service.

⚠ WARNING

DO NOT heat hydraulic pipe. The carbon content of this steel tube is such that if heated for bending, and either water or air quenched, the pipe may lose its ductility and thereby be subject to failure under high pressure conditions. Serious injury can result. Damaged or leaking pipes must be replaced before the system is returned to service. Please contact Oilgear if you require assistance or have questions.

⚠ WARNING

All hydraulic pressure must be relieved from the hydraulic system prior to removing any components from the system. To relieve the hydraulic pressure from the hydraulic system, turn off the motor and operate the control panel with the key in the ON position. Failure to comply can result in serious injury. If you have any questions concerning relieving the hydraulic pressure from the system, please contact Oilgear.

WARNING

Hydraulic components can be heavy. Use caution while lifting these components. Serious personal injury can be avoided with proper handling of the components.

WARNING

Please contact Oilgear if you require assistance. When performing hydraulic test procedures, use the proper hydraulic gauges. Installing an incorrect test gauge could result in serious injury if the gauge fails. Use properly rated hydraulic hoses to allow the test gauge to be read away from moving parts and functions.

WARNING

Increasing hydraulic pressure beyond the recommendations may result in serious damage to the pump and system or serious personal injury and may void the Oilgear Warranty. If you have questions concerning hydraulic pressures or testing procedures, please contact Oilgear before attempting the test procedures or making adjustments.

WARNING

An Oilgear pump or pump control must not be modified in any way without authorization from Oilgear. Modifications may not comply with safety standards, including ANSI safety standards, and may result in serious personal injury. Please contact Oilgear if you require assistance.

WARNING

DO NOT enter under hydraulic supported equipment unless they are fully supported or blocked. Failure to follow this procedure can result in serious injury or death.

WARNING

Any Oilgear pump safety decals must be replaced anytime they are damaged, missing or cannot be read clearly. Failure to have proper decals in place can result in serious injury or death. (If you require safety decals, please contact Oilgear for replacement safety decals, at no charge.)

WARNING

Be sure everyone is clear of the area around the hydraulic system before operating after servicing. Remain attentive at all times when operating to check your work until you are completely sure it is safe to return to service. Failure to heed this warning may result in serious personal injury or death.

WARNING

Wear the proper protective clothing when operating, servicing or maintaining the hydraulic system or the Oilgear pump. Wear the correct protective gear, safety glasses, gloves and safety shoes. Serious injury can result without proper protective gear.

WARNING

Make sure to keep hands, feet and other parts of your body clear of revolving or moving parts. Failure to comply can cause serious injury.

WARNING

DO NOT wear watches, rings or jewelry while working with electrical and mechanical equipment. These items can be hazardous and can cause serious and painful injuries if they come into contact with electrical wires, moving parts or hydraulic equipment.

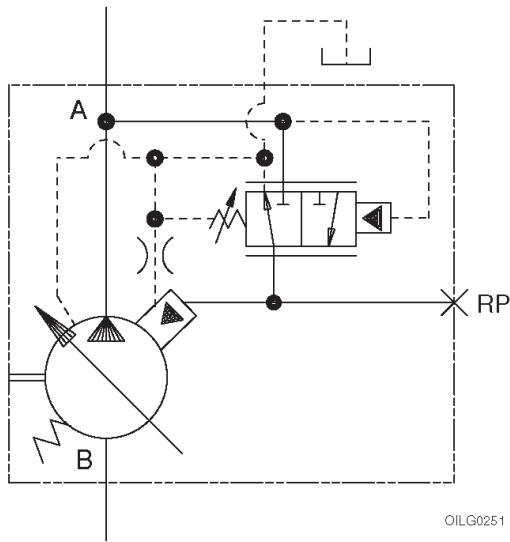

Figure 2. ASA Diagram for "P-1NN" or "P-LNN" Controls Shown with Typical Pump

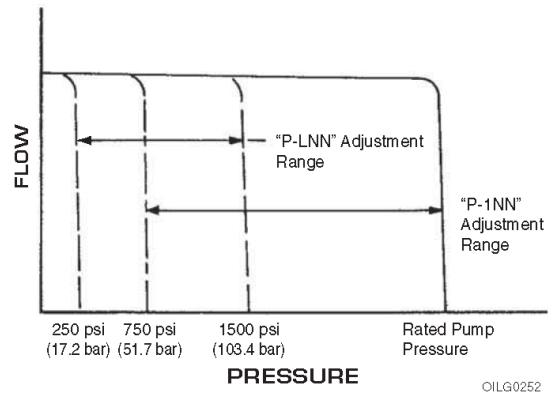

Figure 3. Curve Indicating Flow Versus Pressure for "P-1NN" or "P-LNN" Type Controls

TROUBLESHOOTING

PROBLEM	CAUSES	REMEDY
Unresponsive or Unstable Control	Swashblock bearing surface and/or Saddle Bearings worn or damaged.	See appropriate pump service bulletin.
	Control Pin and/or hole in Swashblock worn significantly.	
	Saddle Bearing Locating Pins broken.	
	Fluid is contaminated.	Inspect and clean if necessary. See bulletin 90007.
	Control Piston orifice (732) plugged.	Inspect and clean if necessary.
	Contamination trapped between control piston (702) and piston bore is not allowing piston to move smoothly.	Inspect and clean if necessary. Replace scored or damaged parts.
	Contamination trapped between control spool (706) and spool bore is not allowing spool to move smoothly.	
	Faulty remote pressure compensator circuit components.	Inspect and replace if necessary.
	Hydraulic line between remote pressure compensator components and RP port of control is too long.	Shorten line length.
	Insufficient control flow.	Increase size of control piston orifice (732).
Insufficient Outlet Volume	Swashblock not stroking to desired displacement.	See appropriate pump service bulletin.
	Low input drive speed.	
	Worn or grooved Cylinder Barrel and/or Valve Plate mating surfaces.	
	Failed Driveshaft.	
	Worn or damaged Piston Shoes or Swashblock.	
	Worn Pistons and/or piston bores.	
	Control Piston stuck off stroke.	Inspect and replace if necessary.
	Maximum Volume Stop adjusted incorrectly.	Adjust Maximum Volume Stop CCW to increase outlet flow.
Pressure Compensator is set too close to operating pressure.	Adjust Pressure Compensator setting CW to increase setting.	
Destrokes at low pressure	Pressure compensator adjustment not set correctly.	Adjust Pressure Compensator setting CW to increase setting and retorque jam nut (715).
	Control Piston orifice (732) plugged.	Inspect and clean if necessary.
	Damaged or fractured control spring (items 708 and/or 709).	Inspect and replace if necessary.
	Severely worn control spool (706) and/or spool bore.	
	Damaged or fractured control piston spring (item 703).	
	Faulty remote pressure compensator circuit components.	
Excessive peak pressure	Pressure Compensator is set too high.	Adjust Pressure Compensator setting CCW to decrease setting.
	Minimum Volume Stop is set too high.	Adjust Minimum Volume Stop CCW to decrease outlet flow.
	Fluid is contaminated.	Inspect and clean if necessary. See bulletin 90007.
	Swashblock bearing surface and/or Saddle Bearings worn or damaged.	See appropriate pump service bulletin.
	Contamination trapped between control piston (702) and piston bore is not allowing piston to move smoothly.	Inspect and clean if necessary. Replace scored or damaged parts.
	Contamination trapped between control spool (706) and spool bore is not allowing spool to move smoothly.	
	Hydraulic line between remote pressure compensator components and RP port of control is too long.	Shorten line length.
	Faulty remote pressure compensator circuit components.	Inspect and replace if necessary.
	Restriction in drilled passages between pump outlet port and control spool.	Inspect and clean if necessary.

PRINCIPLE OF OPERATION

The pressure compensator control ensures maximum pump flow until the system reaches the controls preset pressure setting. The control then regulates the pump output flow to match the flow requirements of the system, while maintaining the preset output pressure.

When the system pressure exceeds the compensator control setting, or the system no longer requires flow, the control de-strokes the pump while maintaining the preset pressure.

“P-1NN” controls can be adjusted from 750 psi (51,7 bar) working pressure up to the maximum pressure rating of the applicable pump. “P-LNN” controls can be adjusted from 250 psi (17,2 bar) up to a maximum of 1500 psi (103,4 bar).

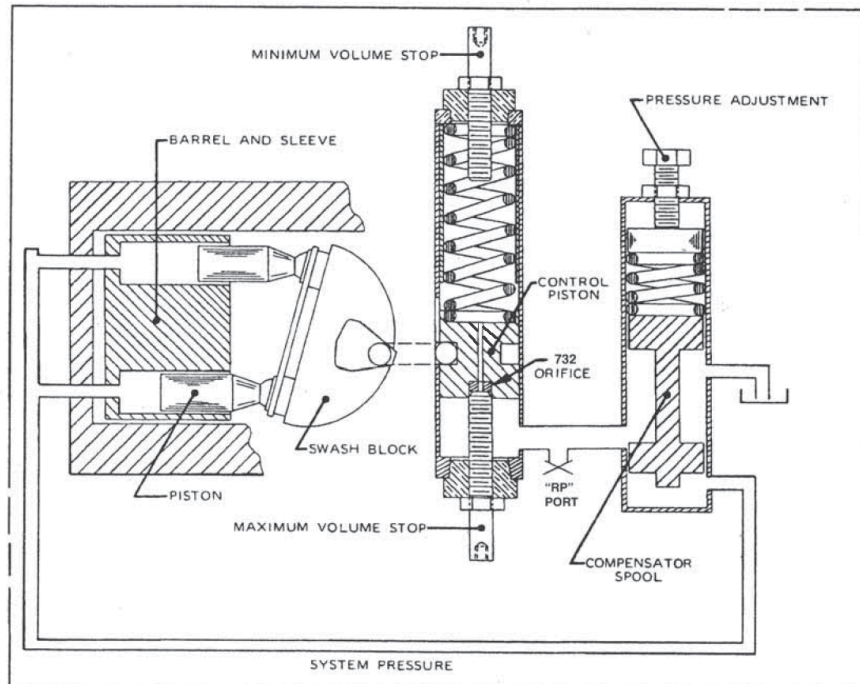

OILG0253

Figure 4. Swashblock at Full Delivery and “P-1NN” or “P-LNN” Controls at Maximum Volume Stop

LINE MOUNTED REMOTE PRESSURE CONTROL FOR TYPE "P-1NN" AND "P-LNN" PUMP CONTROLS - VSR (REMOTE SEQUENCE VALVE)

Remote operation of "P-1NN" and "P-LNN" controls can be accomplished by installing an Oilgear VSR Module at the location shown in the control circuit. Use module L51542 for units rated continuously for 4000 psi (275,8 bar) or less. Use L51542-1 for units rated above 4000 psi (275,8 bar).

NOTE

To minimize case leakage and power loss, plug the control drain port with a #10-24 UNC setscrew to maintain the standard "P-1NN" or "P-LNN" control case leakage. The plug will increase response time. Standard response time can be obtained by installing a .040 inch (1,0 mm) orifice instead of plugging it.

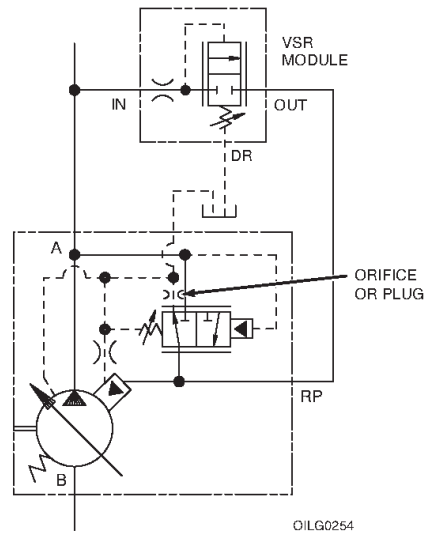
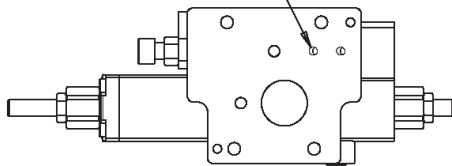

Figure 5. "P-1NN" and "P-LNN" Control Circuit with Remote Pressure Control

DRAIN PORT AS VIEWED FROM UNDERSIDE OF CONTROL BODY. NOTE: THIS IS AN ANGLED HOLE.



OILG0255A

Figure 7. "P-1NN" and "P-LNN" Control Drain Port Location

NOTE

The compensator setting on the pump control must be set at least 200 psi (13,8 bar) higher than the required pressure setting of the remote compensator module to prevent the pump compensator control from interacting with the remote compensator module.

**SCREW AND PLUG TORQUES
FOR CONTROLS**

Item Number	Description	Head Type & Size	Tightening Torque
601	SAE #2 Plug	1/8" Internal Hex	45 in.-lbs (5 N·m)
603	SAE #4 Plug	3/16" Internal Hex	120 in.-lbs (14 N·m)
606	SAE #8 Plug	5/16" Internal Hex	45 ft.-lbs (61 N·m)
711	PC Adjuster Screw LHCS	3/32" Internal Hex	57 in.-lbs (6 N·m)
714	Adjuster Plate Screw	5/32" Internal Hex	80 in.-lbs (9 N·m)
720	Max. or Min. Volume Stop Housing	7/8" External Hex	50 ft.-lbs (68 N·m)
722	End Cap Screws	5/32" Internal Hex	80 in.-lbs (9 N·m)
723	Control Body Screws	3/16" Internal Hex	120 in.-lbs (14 N·m)
732	Control Piston Orifice	3/32" Internal Hex	20 in.-lbs (2.3 N·m)

CONTROL O-RING SEALS

Item Number	ARP 568 Uniform Size Number	Shore A Durometer
1010	-010	90
1011	-011	90
1020	-020	90
1113	-113	90
1145	-145	70
1902	-902	90
1904	-904	90
1908	-908	90

A-Frame PVWJ -011/-014/-022 “P-1NN” and “P-LNN”

PARTS LIST

Parts used in these assemblies are per Oilgear specifications. Use only Oilgear parts to ensure compatibility with assembly requirements. When ordering replacement parts, be sure to include pump type and serial number, bulletin number and item number. Specify type of hydraulic fluid to ensure seal and packing compatibility.

NOTE

Parts drawings may not be identical to Oilgear drawings referenced.

PVWJ A-FRAME -011/-014/-022 PRESSURE COMPENSATOR CONTROLS (“P-1NN” STANDARD & “P-LNN” LOW PRESSURE CONTROLS)

Item	Description
COMMON PARTS GROUP	
601	SAE#2 Plug
603	SAE#4 Plug
606	SAE#8 Plug
701	Control Block
702	Control Piston
703	Control Piston Spring
705	End Cap
706	Pressure Compensator Control Spool
707	Spring Seat
708	Pressure Compensator Spring (Outer)
709*	Pressure Compensator Spring (Inner)
710	Control Plug
711	Screw
712	Shims
713	Adjuster Plate
714	Screw
715	Jam Nut
716	Pressure Compensator Adjustment Screw
717	Min. Volume Stop Stem
718	Max. Volume Stop Stem
719	Jam Nut
720	Volume Stop Housing
721	Control Pin
722	Screw, End Cap
723	Screw, Control Body
732	Orifice
1010	O-Ring
1011	O-Ring
1020	O-Ring
1113	O-Ring
1145	O-Ring
1902	O-Ring
1904	O-Ring
1908	O-Ring

*Only used in P-1 Control.

A-Frame PVWJ -011/-014/-022 “P-1NN” and “P-LNN”

SERVICE KITS

Document Number: 519975-SK1

PVWJ Service Kits

Revision: New

Reference 519975-101
SERVICE KIT, Figures 8 & 9

Description	Kit No.	Design Series	Items Included (quantity is 1 unless noted)
Main Control Body Kits			
PVWJ-011	K50460-100	A1	701, 706
PVWJ-014/-022	K50460-200	A1	701, 706
Control Piston Kits			
All Models	K50521	A1	702, 732
Pressure Compensator Spools			
PVWJ-011	50015-100	A1	706
PVWJ-014/-022	50015-200	A1	706
Control Spring Kits			
P-LNN (All Models)	K50036-103	A1	703, 708
PVWJ-011 P-1NN	K50036-106	A1	703, 708
PVWJ-014/-022 P-1NN	K50036-109	A1	703, 708, 709
Control Pins			
All Models	50623-5	A1	721
Volume Stop Kits			
Maximum Volume Stop (All Models)	K50590	A1	718, 719, 720, 1011, 1908
Minimum Volume Stop (All Models)	K50590-100	A1	705, 717, 719, 720, 1011, 1020, 1908
Pressure Compensator Adjuster Kits			
All Models	K50660-100	A1	710, 711, 712, 713, 715, 716, 1113
Control Seal Kit			
All Models	K50824-100	A1	1010, 1011, 1020, 1113, 1145, 1902, 1904, 1908

A-Frame PVWJ -011/-014/-022 "P-1NN" and "P-LNN"

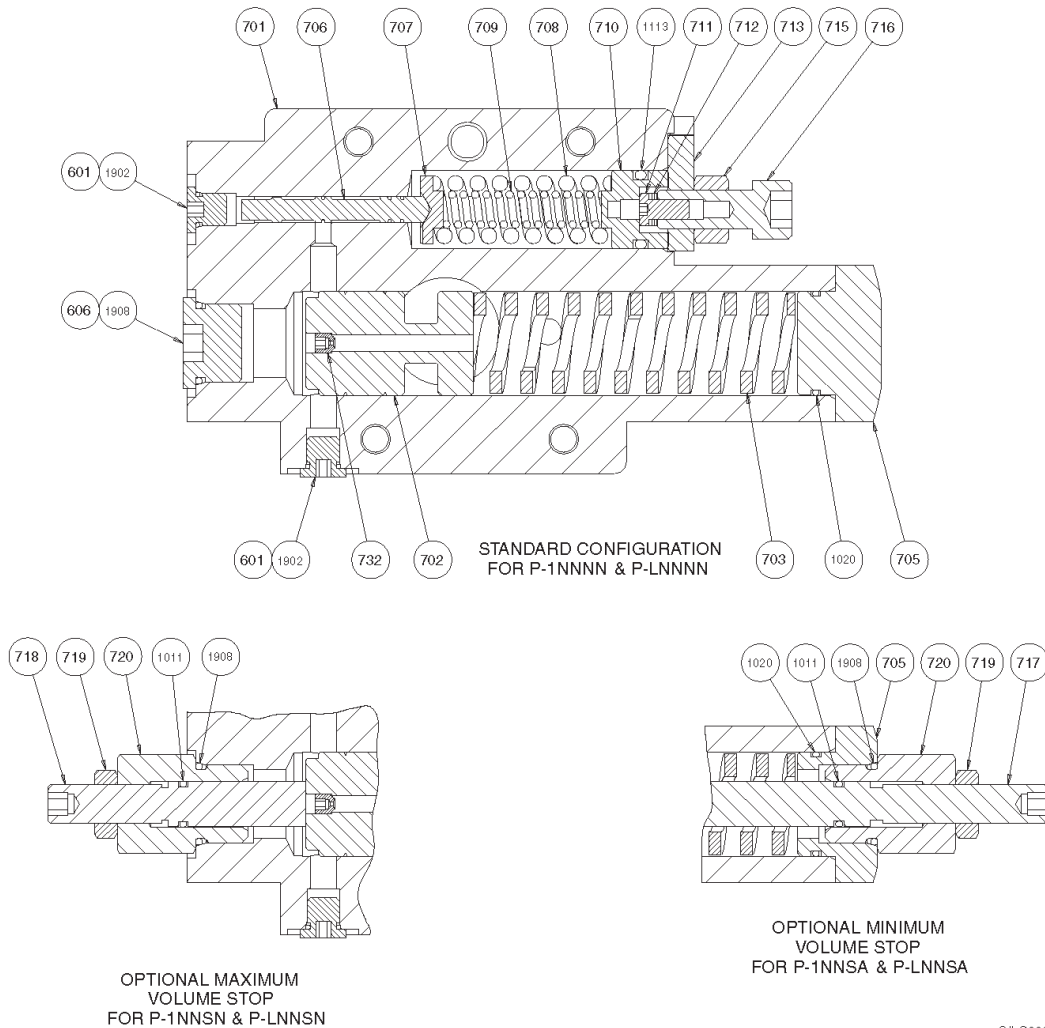

OILG0256

Figure 8. Parts Drawing for "P-1NN" and "P-LNN" Control (519975-101 sheet 1)

MAXIMUM AND MINIMUM VOLUME STOP

The maximum volume stop can be adjusted to attain a maximum volume from full to 25% of full flow. The pump can be de-stroked from full to 25% flow with eight half-turns of the volume stop. One turn clockwise will decrease maximum pump outlet flow 9%.

The minimum volume stop can be adjusted to attain a minimum volume from zero to full flow. One turn clockwise will increase minimum pump outlet flow 9%.

A-Frame PVWJ -011/-014/-022 "P-1NN" and "P-LNN"

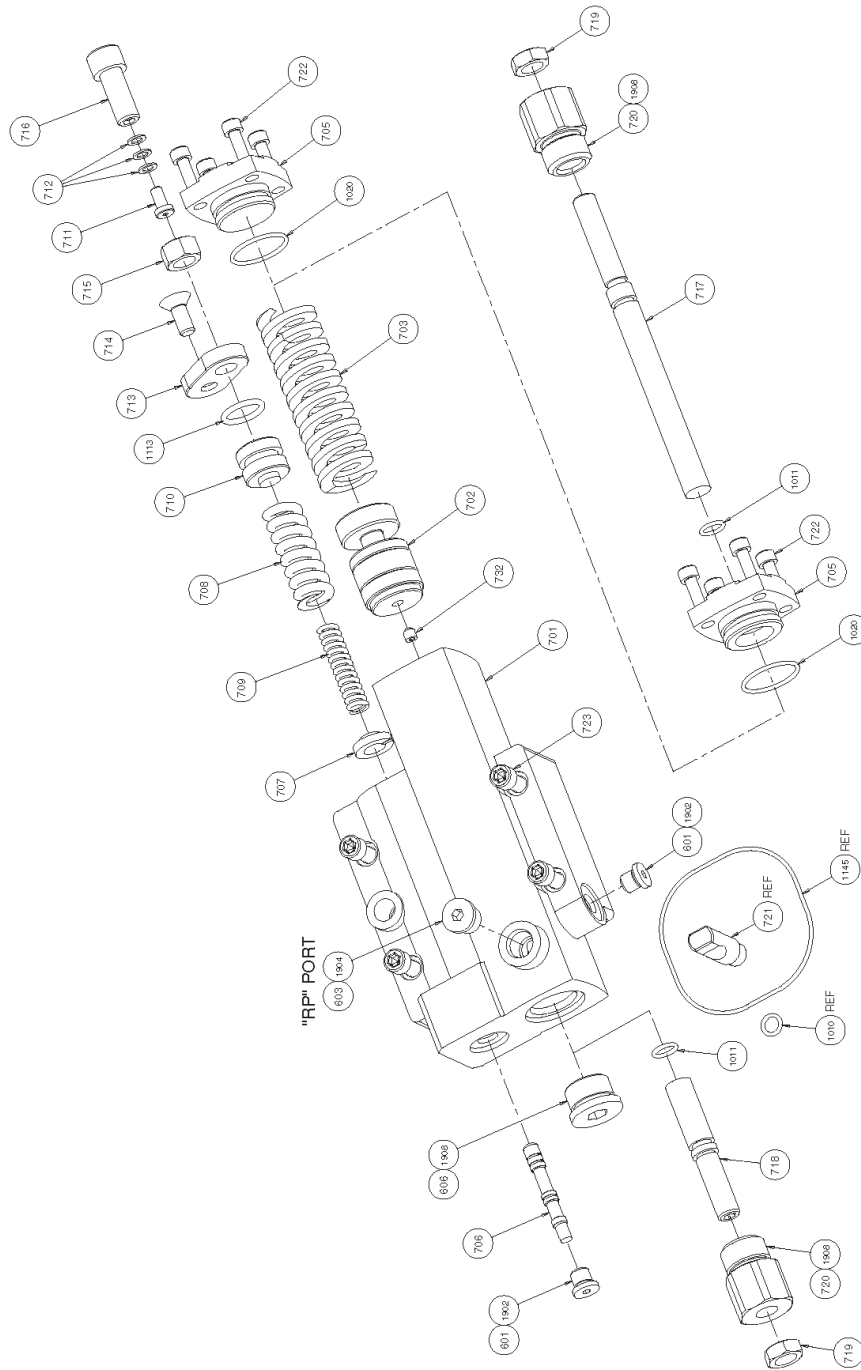

OILG0257

Figure 9. Exploded Parts Drawing for "P-1NN" and "P-LNN" Control (519975-101 sheet 2)

AFTER SALES SERVICES

At Oilgear we build products to last. It is the nature of this type of machinery to require proper maintenance regardless of the care we put into manufacturing. Oilgear has several service programs in place to help you.

STAY-ON-STREAM SERVICE

By signing up for Oilgear's Stay-On-Stream program, you can prepare for problems before they happen. Certain field tests such as fluid testing, slip testing and electronic profile recording comparisons can be performed by our field service people or your own factory trained personnel. These tests can indicate problems before they become "down-time" difficulties.

SERVICE SCHOOLS

Oilgear conducts training to train your maintenance personnel. "General" hydraulic or electronic training is conducted at our Milwaukee, Wisconsin plant on a regular basis. "Custom" training, specifically addressing your particular hydraulic and electro-hydraulic equipment, can be conducted at your facilities.

SPARE PARTS AVAILABILITY

Prepare for your future needs by stocking Oilgear original factory parts. Having the correct parts and necessary skills "in-plant" enables you to minimize "down-time." Oilgear has developed parts kits to cover likely future needs. Oilgear Field Service Technicians are also ready to assist you and your maintenance people in troubleshooting and repairing equipment.



SERVICE INSTRUCTIONS

“PVWJ” B-FRAME PUMPS -025/-034/-046 FOR TYPE “P-1NN” AND “P-LNN” PRESSURE COMPENSATING CONTROLS

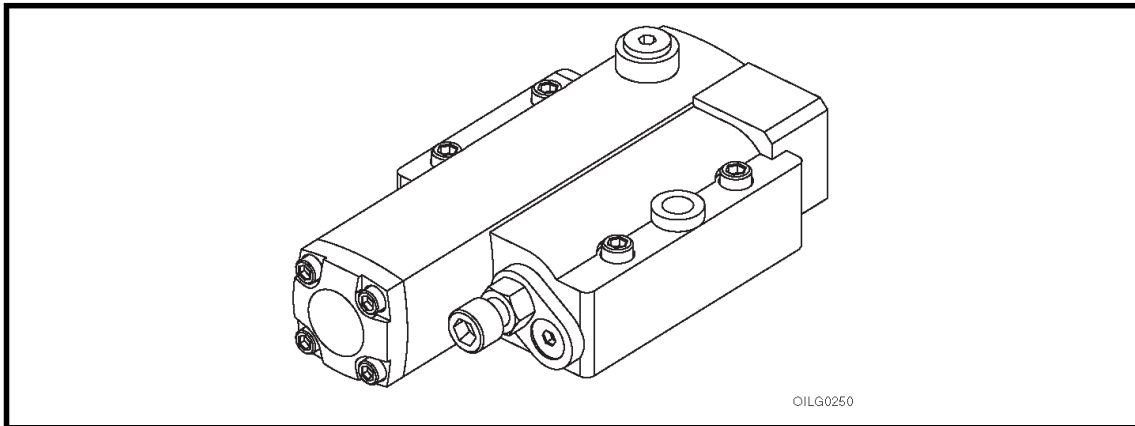

Figure 1. Typical Oilgear Type “P-1NN” and “P-LNN” Pressure Compensator Controls for “PVWJ” B-Frame Pump

PURPOSE OF INSTRUCTIONS

These instructions will simplify the installation, operation and maintenance of Oilgear type “P-1NN” and “P-LNN” controlled units.

This material will inform you about the basic construction, principle of operation and service parts listings. Some controls may be modified for specific applications from those described in this bulletin and other changes may be made without notice.

REFERENCE MATERIAL

Fluid Recommendations	Bulletin 90000
Contamination Evaluation Guide	Bulletin 90004
Filtration Recommendations	Bulletin 90007
Piping Information	Bulletin 90011
Proper Installation of Vertical Pumps	Bulletin 90014
PVWJ Open Loop Pumps, Application Guidelines	Bulletin 847085
PVWJ Open Loop Pumps (All Frame Sizes) Service Instructions	Bulletin 947085
PVWJ Open Loop Pumps, Sales	Bulletin 47085

PVWJ PUMP INSTALLATIONS

PVWJ B Frame (PVWJ-025/-034/-046) w/ Rear Ports	DS-47483
PVWJ B Frame (PVWJ-025/-034/-046) w/ Side Ports	DS-47484
PVWJ B Frame (PVWJ-025/-034/-046) w/ Side Ports & Thru Shaft	DS-47485

PVWJ PUMP CONTROL INSTALLATIONS

“P-1NN” and “P-LNN” Pressure Compensator for PVWJ-025/-034/-046	DS-47985
---	----------

THE OILGEAR COMPANY
2300 South 51st Street
Milwaukee, Wisconsin 53219
www.oilgear.com

Safety First

Read and understand this entire instruction sheet before repairing, or adjusting your Oilgear product.

Those who use and maintain this equipment must be thoroughly trained and familiar with the product. If incorrectly used or maintained, this product and its equipment can cause severe injury.

SAFETY SYMBOLS

The following signal words are used in this instruction sheet to identify areas of concern where your safety may be involved. Carefully read the text and observe any instructions provided to ensure your safety.

DANGER

THIS SIGNAL WORD INDICATES AN IMMEDIATELY HAZARDOUS SITUATION WHICH, IF NOT AVOIDED, WILL RESULT IN DEATH OR SERIOUS INJURY.

WARNING

This signal word indicates a potentially hazardous situation which, if not avoided, could result in death or serious injury.

CAUTION

This signal word indicates that a potentially hazardous situation exists which, if not avoided, may result in damage to equipment or minor personal injury.

NOTE

While not directly relevant to the topic being discussed, the NOTE is used to emphasize information provided, or provide additional information which may be of benefit.

WARNING

This service information is designed for the maintenance of your Oilgear product. It contains the information on the correct procedures determined by Oilgear for the safe manner of servicing. Always keep this instruction sheet in a location where it is readily available for the persons who use and maintain the product. Additional copies of this instruction sheet are available through the Oilgear Company. Contact us at 414-327-1700 or visit our website: www.oilgear.com. Please contact us if you have any questions regarding the information in this instruction bulletin.

NOTE

The cleanliness of working on this pump control or the hydraulic system is extremely important to the safety and reliability of the pump and the system. Always make sure the fittings are clean on the outside before removing them from their connections, are capped and plugged when removed and placed in a clean rag or container until they are reinstalled.

WARNING

Some service operations may require special tools or equipment. If you require information on these items, please contact Oilgear before attempting these repairs and service operations.

WARNING

Read, understand and follow the safety guidelines, dangers and warnings contained in this instruction sheet to promote reliable operation and prevent serious personal injury.

WARNING

DO NOT attempt to service this machinery in an environment where safety regulations are not established and in place.

WARNING

DO NOT operate the hydraulic system if a leak is present. Serious injury may result.

WARNING

Hydraulic systems operate under very high pressure. Hydraulic fluid escaping from a pressurized system can penetrate unprotected body tissue. DO NOT inspect for hydraulic leaks with bare hands or other exposed body parts. As a minimum, wear leather gloves prior to inspecting for leaks and use cardboard or wood. If leaks are present, relieve pressure and allow system to cool prior to servicing. If injured by escaping hydraulic oil, contact a physician immediately. Serious complications may arise if not treated immediately. If you have questions regarding inspecting for hydraulic leaks, please contact Oilgear prior to servicing.

⚠ WARNING

Hydraulic hoses and tubing must be inspected on a daily basis for leaks, cuts, abrasions, damage and improper clearance along any mounting frame for hidden damage before the unit is put into service. Replace damaged hoses or hoses you suspect are damaged before the system is returned to service! Hoses must be replaced every two years. Failure to properly inspect and maintain the system may result in serious injury.

⚠ WARNING

Hydraulic systems are hot. DO NOT TOUCH! Serious personal injury may result from hot oil. When you have completed working on the hydraulic system, thoroughly clean any spilled oil from the equipment. Do not spill any hydraulic fluids on the ground. Clean any hydraulic fluids from your skin as soon as you have completed maintenance and repairs. Dispose of used oil and system filters as required by law.

⚠ WARNING

Use correct hoses, fittings, and adapters with the correct SAE rating when replacing hoses to prevent possible serious injury. Always replace hoses, fittings and adapters with replacements that have a proper, suitable, working pressure rating. Replacement hoses must be of the correct length and must comply with the hose manufacturer's and Oilgear's installation guidelines and recommendations.

⚠ WARNING

Hydraulic hoses have the SAE ratings marked on the hose to assist you in selecting the correct hose. The same manufacturer must supply any replacement hydraulic hoses and fitting assemblies. As an example: Brand "X" hose and brand "Y" fitting will not normally be compatible. No "Twist" is allowed in the hydraulic hoses. "Twist" may result in premature hose failure. This can cause serious injury. Please contact Oilgear for assistance when required.

⚠ WARNING

Hydraulic cylinders can be holding a function in a certain position when the pump is OFF. An example of this is a function being held in the lift or partial lift position by the cylinders. If a hydraulic line is removed or the hydraulic circuits or controls are being worked on, gravity may allow the function being held in position to drop. All workers and personnel must remain clear of these areas when working on or operating the hydraulic system. Block and secure all devices and functions which apply before beginning work or operation. Failure to comply with this can result in serious injury or death.

⚠ WARNING

Any hydraulic pipe which is replaced must conform to SAE J1065 specifications. If incorrect hydraulic pipe is installed, the hydraulic system may fail, causing serious injury. Damaged or leaking fittings, pipes or hoses must be replaced before the system is returned to service.

⚠ WARNING

DO NOT heat hydraulic pipe. The carbon content of this steel tube is such that if heated for bending, and either water or air quenched, the pipe may lose its ductility and thereby be subject to failure under high pressure conditions. Serious injury can result. Damaged or leaking pipes must be replaced before the system is returned to service. Please contact Oilgear if you require assistance or have questions.

⚠ WARNING

All hydraulic pressure must be relieved from the hydraulic system prior to removing any components from the system. To relieve the hydraulic pressure from the hydraulic system, turn off the motor and operate the control panel with the key in the ON position. Failure to comply can result in serious injury. If you have any questions concerning relieving the hydraulic pressure from the system, please contact Oilgear.

WARNING

Hydraulic components can be heavy. Use caution while lifting these components. Serious personal injury can be avoided with proper handling of the components.

WARNING

Please contact Oilgear if you require assistance. When performing hydraulic test procedures, use the proper hydraulic gauges. Installing an incorrect test gauge could result in serious injury if the gauge fails. Use properly rated hydraulic hoses to allow the test gauge to be read away from moving parts and functions.

WARNING

Increasing hydraulic pressure beyond the recommendations may result in serious damage to the pump and system or serious personal injury and may void the Oilgear Warranty. If you have questions concerning hydraulic pressures or testing procedures, please contact Oilgear before attempting the test procedures or making adjustments.

WARNING

An Oilgear pump or pump control must not be modified in any way without authorization from Oilgear. Modifications may not comply with safety standards, including ANSI safety standards, and may result in serious personal injury. Please contact Oilgear if you require assistance.

WARNING

DO NOT enter under hydraulic supported equipment unless they are fully supported or blocked. Failure to follow this procedure can result in serious injury or death.

WARNING

Any Oilgear pump safety decals must be replaced anytime they are damaged, missing or cannot be read clearly. Failure to have proper decals in place can result in serious injury or death. (If you require safety decals, please contact Oilgear for replacement safety decals, at no charge.)

WARNING

Be sure everyone is clear of the area around the hydraulic system before operating after servicing. Remain attentive at all times when operating to check your work until you are completely sure it is safe to return to service. Failure to heed this warning may result in serious personal injury or death.

WARNING

Wear the proper protective clothing when operating, servicing or maintaining the hydraulic system or the Oilgear pump. Wear the correct protective gear, safety glasses, gloves and safety shoes. Serious injury can result without proper protective gear.

WARNING

Make sure to keep hands, feet and other parts of your body clear of revolving or moving parts. Failure to comply can cause serious injury.

WARNING

DO NOT wear watches, rings or jewelry while working with electrical and mechanical equipment. These items can be hazardous and can cause serious and painful injuries if they come into contact with electrical wires, moving parts or hydraulic equipment.

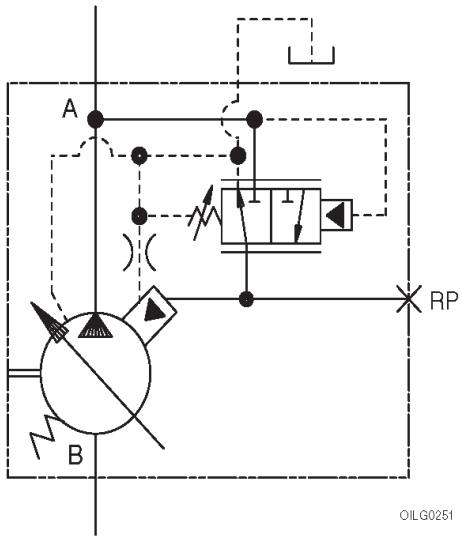

Figure 2. ASA Diagram for "P-1NN" or "P-LNN" Controls Shown with Typical Pump

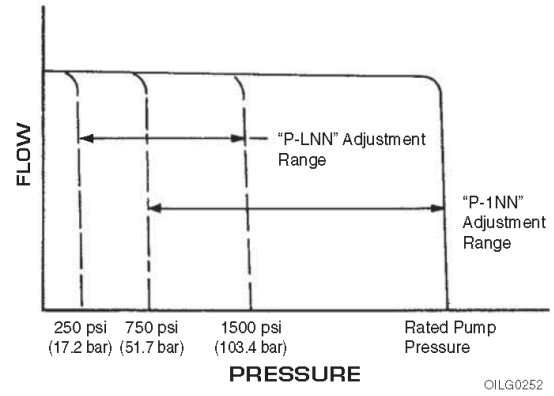

Figure 3. Curve Indicating Flow Versus Pressure for "P-1NN" or "P-LNN" Type Controls

TROUBLESHOOTING		
PROBLEM	CAUSES	REMEDY
Unresponsive or Unstable Control	Swashblock bearing surface and/or Saddle Bearings worn or damaged.	See appropriate pump service bulletin.
	Control Pin and/or hole in Swashblock worn significantly.	
	Saddle Bearing Locating Pins broken.	
	Fluid is contaminated.	Inspect and clean if necessary. See bulletin 90007.
	Control Piston orifice (732) plugged.	Inspect and clean if necessary.
	Contamination trapped between control piston (702) and piston bore is not allowing piston to move smoothly.	Inspect and clean if necessary. Replace scored or damaged parts.
	Contamination trapped between control spool (706) and spool bore is not allowing spool to move smoothly.	
	Faulty remote pressure compensator circuit components.	Inspect and replace if necessary.
	Hydraulic line between remote pressure compensator components and RP port of control is too long.	Shorten line length.
	Insufficient control flow.	Increase size of control piston orifice (732).
Insufficient Outlet Volume	Swashblock not stroking to desired displacement.	See appropriate pump service bulletin.
	Low input drive speed.	
	Worn or grooved Cylinder Barrel and/or Valve Plate mating surfaces.	
	Failed Driveshaft.	
	Worn or damaged Piston Shoes or Swashblock.	
	Worn Pistons and/or piston bores.	
	Control Piston stuck off stroke.	Inspect and replace if necessary.
	Maximum Volume Stop adjusted incorrectly.	Adjust Maximum Volume Stop CCW to increase outlet flow.
Pressure Compensator is set too close to operating pressure.	Adjust Pressure Compensator setting CW to increase setting.	
Destrokes at low pressure	Pressure compensator adjustment not set correctly.	Adjust Pressure Compensator setting CW to increase setting and retorque jam nut (715).
	Control Piston orifice (732) plugged.	Inspect and clean if necessary.
	Damaged or fractured control spring (items 708 and/or 709).	Inspect and replace if necessary.
	Severely worn control spool (706) and/or spool bore.	
	Damaged or fractured control piston spring (item 703).	
	Faulty remote pressure compensator circuit components.	
Excessive peak pressure	Pressure Compensator is set too high.	Adjust Pressure Compensator setting CCW to decrease setting.
	Minimum Volume Stop is set too high.	Adjust Minimum Volume Stop CCW to decrease outlet flow.
	Fluid is contaminated.	Inspect and clean if necessary. See bulletin 90007.
	Swashblock bearing surface and/or Saddle Bearings worn or damaged.	See appropriate pump service bulletin.
	Contamination trapped between control piston (702) and piston bore is not allowing piston to move smoothly.	Inspect and clean if necessary. Replace scored or damaged parts.
	Contamination trapped between control spool (706) and spool bore is not allowing spool to move smoothly.	
	Hydraulic line between remote pressure compensator components and RP port of control is too long.	Shorten line length.
	Faulty remote pressure compensator circuit components.	Inspect and replace if necessary.
	Restriction in drilled passages between pump outlet port and control spool.	Inspect and clean if necessary.

PRINCIPLE OF OPERATION

The pressure compensator control ensures maximum pump flow until the system reaches the controls preset pressure setting. The control then regulates the pump output flow to match the flow requirements of the system, while maintaining the preset output pressure.

When the system pressure exceeds the compensator control setting, or the system no longer requires flow, the control de-strokes the pump while maintaining the preset pressure.

“P-1NN” controls can be adjusted from 750 psi (51,7 bar) working pressure up to the maximum pressure rating of the applicable pump. “P-LNN” controls can be adjusted from 250 psi (17,2 bar) up to a maximum of 1500 psi (103,4 bar).

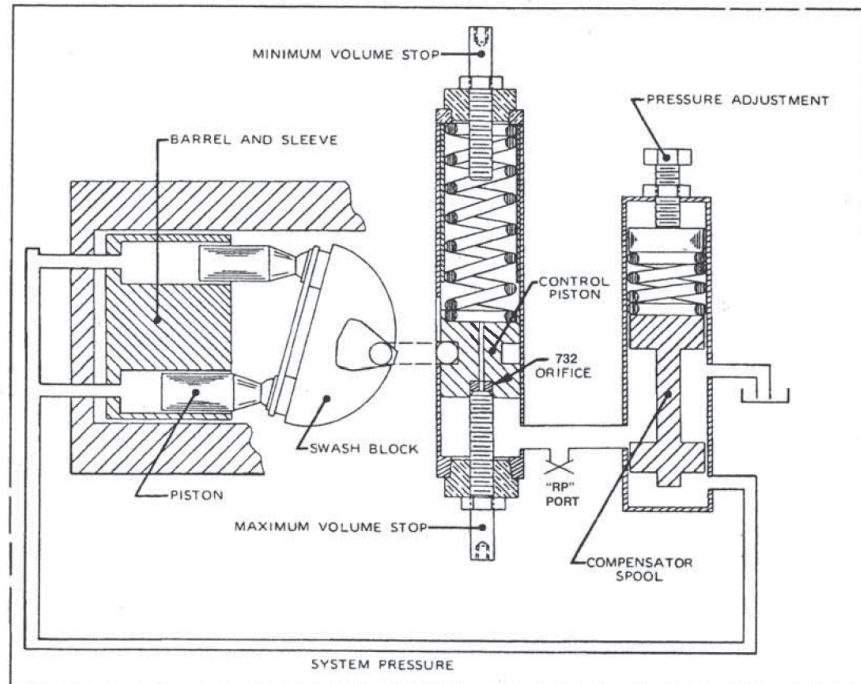

OILG0253

Figure 4. Swashblock at Full Delivery and “P-1NN” or “P-LNN” Controls at Maximum Volume Stop

LINE MOUNTED REMOTE PRESSURE CONTROL FOR TYPE "P-1NN" AND "P-LNN" PUMP CONTROLS - VSR (REMOTE SEQUENCE VALVE)

Remote operation of "P-1NN" and "P-LNN" controls can be accomplished by installing an Oilgear VSR Module at the location shown in the control circuit. Use module L51542 for units rated continuously for 4000 psi (275,8 bar) or less. Use L51542-1 for units rated above 4000 psi (275,8 bar).

NOTE To minimize case leakage and power loss, plug the control drain port with a #10-24 UNC setscrew to maintain the standard "P-1NN" or "P-LNN" control case leakage. The plug will increase response time. Standard response time can be obtained by installing a .040 inch (1,0 mm) orifice instead of plugging it.

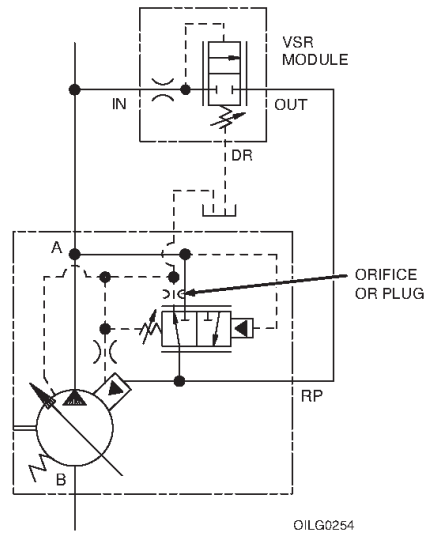
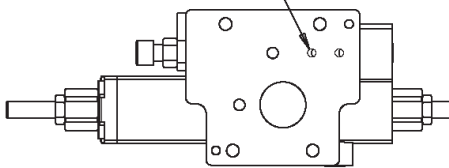

Figure 5. "P-1NN" and "P-LNN" Control Circuit with Remote Pressure Control

DRAIN PORT AS VIEWED FROM UNDERSIDE OF CONTROL BODY.



OILG0255

Figure 7. "P-1NN" and "P-LNN" Control Drain Port Location

NOTE The compensator setting on the pump control must be set at least 200 psi (13,8 bar) higher than the required pressure setting of the remote compensator module to prevent the pump compensator control from interacting with the remote compensator module.

**SCREW AND PLUG TORQUES
FOR CONTROLS**

Item Number	Description	Head Type & Size	Tightening Torque
601	SAE #2 Plug	1/8" Internal Hex	45 in.-lbs (5 N·m)
603	SAE #4 Plug	3/16" Internal Hex	120 in.-lbs (14 N·m)
606	SAE #8 Plug	5/16" Internal Hex	45 ft-lbs (61 N·m)
711	PC Adjuster Screw LHCS	3/32" Internal Hex	57 in.-lbs (6 N·m)
714	Adjuster Plate Screw	5/32" Internal Hex	80 in.-lbs (9 N·m)
720	Max. or Min. Volume Stop Housing	7/8" External Hex	50 ft-lbs (68 N·m)
722	End Cap Screws	3/16" Internal Hex	120 in.-lbs (14 N·m)
723	Control Body Screws	3/16" Internal Hex	120 in.-lbs (14 N·m)
732	Control Piston Orifice	3/32" Internal Hex	20 in.-lbs (2.3 N·m)

CONTROL O-RING SEALS

Item Number	ARP 568 Uniform Size Number	Shore A Durometer
1010	-010	90
1011	-011	90
1113	-113	90
1125	-125	90
1237	-237	70
1902	-902	90
1904	-904	90
1908	-908	90

B-Frame PVWJ -025/-034/-046 “P-1NN” and “P-LNN”

PARTS LIST

Parts used in these assemblies are per Oilgear specifications. Use only Oilgear parts to ensure compatibility with assembly requirements. When ordering replacement parts, be sure to include pump type and serial number, bulletin number and item number. Specify type of hydraulic fluid to ensure seal and packing compatibility.

NOTE

Parts drawings may not be identical to Oilgear drawings referenced.

PVWJ-025/-034/-046 PRESSURE COMPENSATOR CONTROLS (“P-1NN” STANDARD & “P-LNN” LOW PRESSURE CONTROLS)

Item	Description
COMMON PARTS GROUP	
601	SAE#2 Plug
603	SAE#4 Plug
606	SAE#8 Plug
701	Control Block
702	Control Piston
703	Control Piston Spring
704	Piston Stop
705	End Cap
706	Pressure Compensator Control Spool
707	Spring Seat
708	Pressure Compensator Spring (Outer)
709*	Pressure Compensator Spring (Inner)
710	Control Plug
711	Screw
712	Shims
713	Adjuster Plate
714	Screw
715	Jam Nut
716	Pressure Compensator Adjustment Screw
717	Min. Volume Stop Stem
718	Max. Volume Stop Stem
719	Jam Nut
720	Volume Stop Housing
721	Control Pin
722	Screw, End Cap
723	Screw, Control Body
732	Orifice
1010	O-Ring
1011	O-Ring
1113	O-Ring
1125	O-Ring
1237	O-Ring
1902	O-Ring
1904	O-Ring
1908	O-Ring

*Only used in P-1 Control.

B-Frame PVWJ -025/-034/-046 “P-1NN” and “P-LNN”

SERVICE KITS

Document Number: 519975-SK2

PVWJ Service Kits

Revision: New

Reference 519975-201
SERVICE KIT, Figures 8 & 9

Description	Kit No.	Design Series	Items Included (quantity is 1 unless noted)
Main Control Body Kits			
PVWJ-025	K50432-100	A1	701, 706
PVWJ-034/-046	K50432-200	A1	701, 706
Control Piston Kits			
All Models	K50484	A1	702, 732
Pressure Compensator Spools			
PVWJ-025	50015-100	A1	706
PVWJ-034/-046	50015-200	A1	706
Control Spring Kits			
P-LNN (All Models)	K50036-104	A1	703, 708
PVWJ-025 P-1NN	K50036-107	A1	703, 708
PVWJ-034/-046 P-1NN	K50036-110	A1	703, 708, 709
Control Pins			
All Models	51339-5	A1	721
Volume Stop Kits			
Maximum Volume Stop (All Models)	K50590	A1	718, 719, 720, 1011, 1908
Minimum Volume Stop (All Models)	K50590-200	A1	705, 717, 719, 720, 1011, 1020, 1908
Pressure Compensator Adjuster Kits			
All Models	K50660-200	A1	710, 711, 712, 713, 715, 716, 1113
Control Seal Kit			
All Models	K50824-200	A1	1010, 1011, 1113, 1125, 1237, 1902, 1904, 1908

B-Frame PVWJ -025/-034/-046 "P-1NN" and "P-LNN"

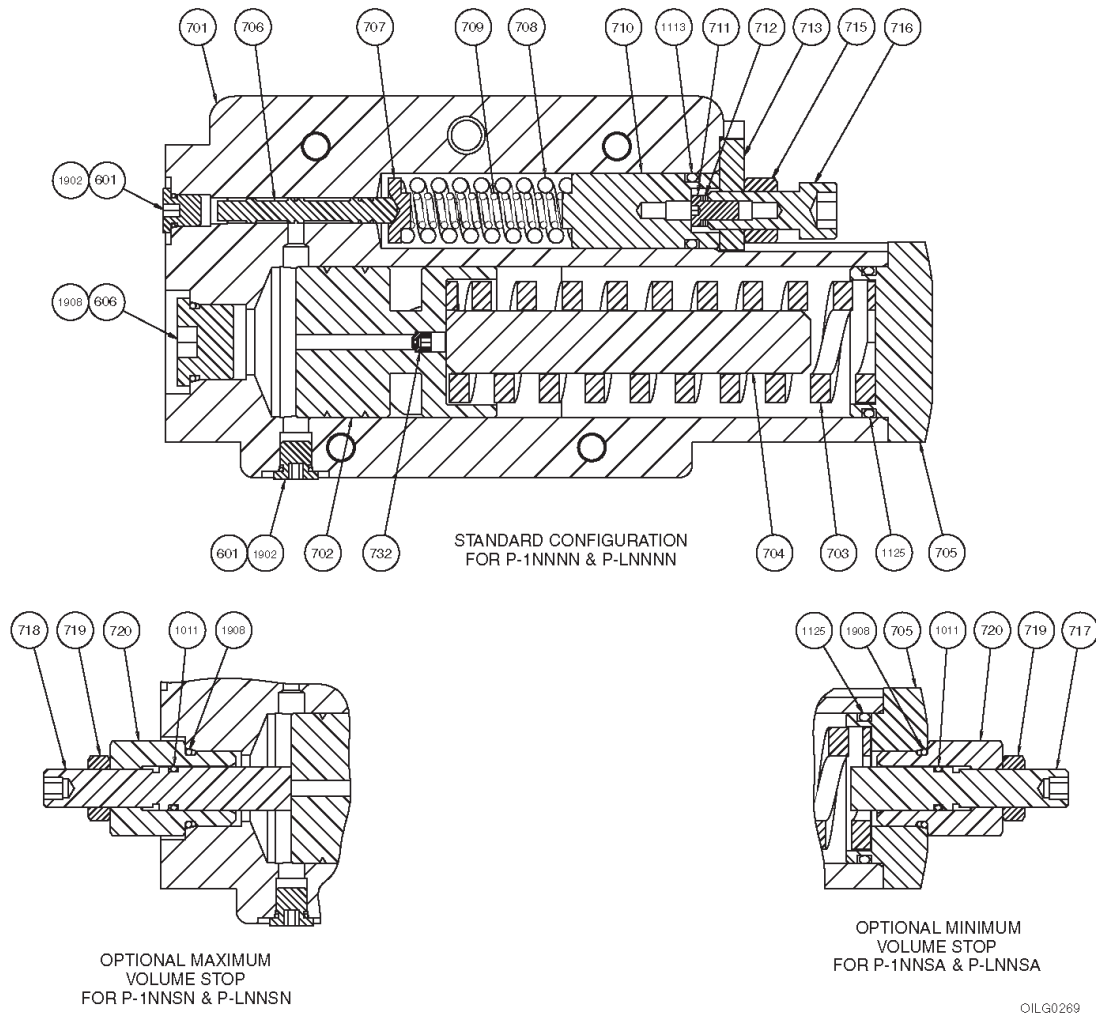

Figure 8. Parts Drawing for "P-1NN" and "P-LNN" Control (519975-201 sheet 1)

MAXIMUM AND MINIMUM VOLUME STOP

The maximum volume stop can be adjusted to attain a maximum volume from full to 25% of full flow. The pump can be de-stroked from full to 25% flow with 11 turns of the volume stop. One turn clockwise will decrease maximum pump outlet flow 7%.

The minimum volume stop can be adjusted to attain a minimum volume from zero to full flow. The adjustment requires 14 turns to go from zero to full flow. One turn clockwise will increase minimum pump outlet flow 9%.

B-Frame PVWJ -025/-034/-046 "P-1NN" and "P-LNN"

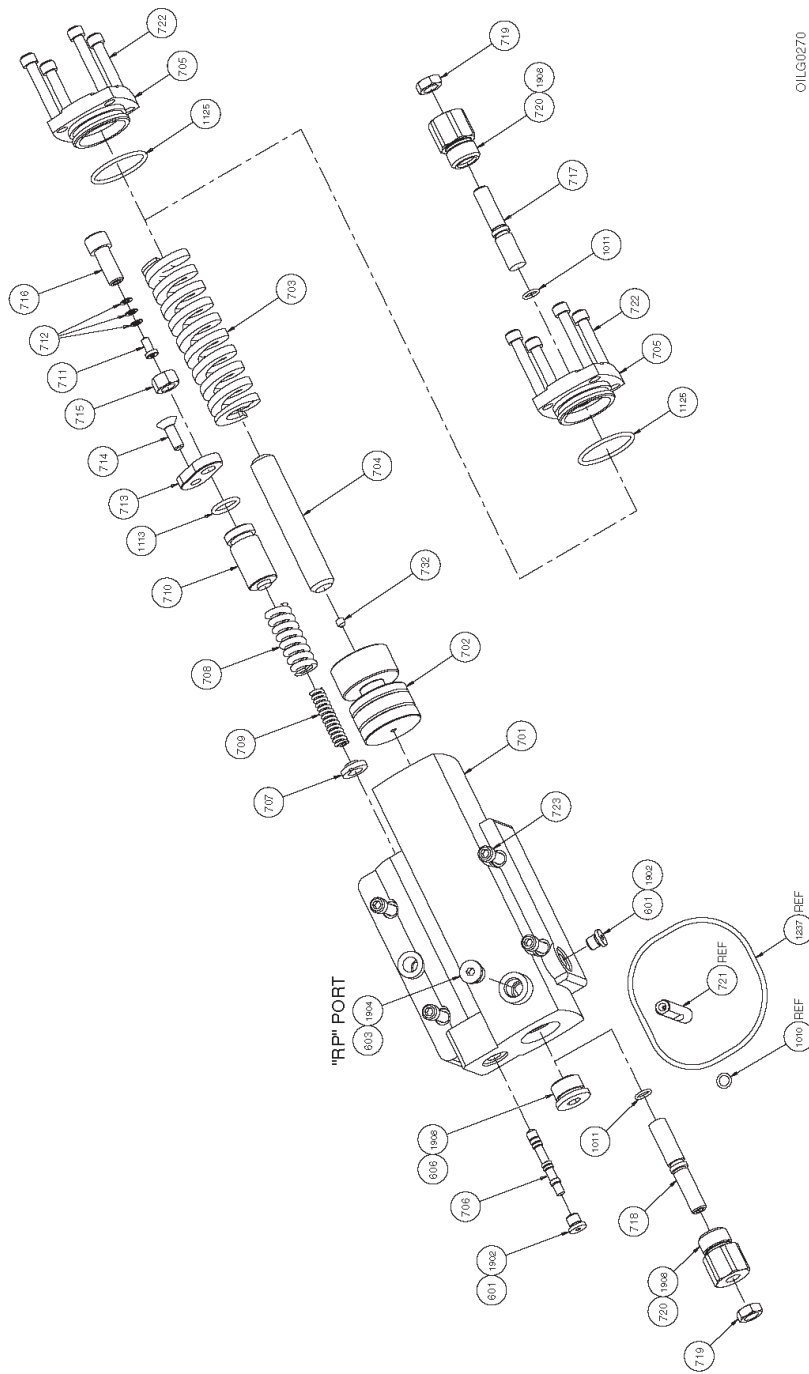

OILG0270

Figure 9. Exploded Parts Drawing for "P-1NN" and "P-LNN" Control (519975-201 sheet 2)

AFTER SALES SERVICES

At Oilgear we build products to last. It is the nature of this type of machinery to require proper maintenance regardless of the care we put into manufacturing. Oilgear has several service programs in place to help you.

STAY-ON-STREAM SERVICE

By signing up for Oilgear's Stay-On-Stream program, you can prepare for problems before they happen. Certain field tests such as fluid testing, slip testing and electronic profile recording comparisons can be performed by our field service people or your own factory trained personnel. These tests can indicate problems before they become "down-time" difficulties.

SERVICE SCHOOLS

Oilgear conducts training to train your maintenance personnel. "General" hydraulic or electronic training is conducted at our Milwaukee, Wisconsin plant on a regular basis. "Custom" training, specifically addressing your particular hydraulic and electro-hydraulic equipment, can be conducted at your facilities.

SPARE PARTS AVAILABILITY

Prepare for your future needs by stocking Oilgear original factory parts. Having the correct parts and necessary skills "in-plant" enables you to minimize "down-time." Oilgear has developed parts kits to cover likely future needs. Oilgear Field Service Technicians are also ready to assist you and your maintenance people in troubleshooting and repairing equipment.





APPENDIX VII

**Safety Data Sheet
(SDS)
Hydraulic Fluid**

Skydrol® LD4 Fire Resistant Hydraulic Fluid

Version Revision Date: SDS Number: Date of last issue: 06/02/2015
2.2 08/09/2016 150000093409 Date of first issue: 10/24/2013
SDSUS / PRD / 0001

SECTION 1. IDENTIFICATION

Product name : Skydrol® LD4 Fire Resistant Hydraulic Fluid

Product code : P3410201

Manufacturer or supplier's details

Company name of supplier : Eastman Chemical Company

Address : 200 South Wilcox Drive
 Kingsport TN 37660-5280

Telephone : (423) 229-2000

Emergency telephone number : CHEMTREC: +1-800-424-9300, +1-703-527-3887 CCN7321
 For emergency transportation information, in the United States:
 call CHEMTREC at 800-424-9300 or call 423-229-2000.

Recommended use of the chemical and restrictions on use

Recommended use : Hydraulic fluids

Restrictions on use : None known.

SECTION 2. HAZARDS IDENTIFICATION**GHS Classification**

Skin irritation : Category 2

Carcinogenicity : Category 2

GHS label elements

Hazard pictograms :



Signal word : Warning

Hazard statements : H315 Causes skin irritation.
 H351 Suspected of causing cancer.

Precautionary statements : **Prevention:**
 P201 Obtain special instructions before use.
 P202 Do not handle until all safety precautions have been read
 and understood.
 P264 Wash skin thoroughly after handling.
 P280 Wear protective gloves/ protective clothing/ eye protection/
 face protection.

Skydrol® LD4 Fire Resistant Hydraulic Fluid

Version 2.2 Revision Date: 08/09/2016 SDS Number: 150000093409 Date of last issue: 06/02/2015
 Date of first issue: 10/24/2013

SDSUS / PRD / 0001

Response:

P302 + P352 IF ON SKIN: Wash with plenty of soap and water.
 P308 + P313 IF exposed or concerned: Get medical advice/
 attention.

P332 + P313 If skin irritation occurs: Get medical advice/
 attention.

P362 Take off contaminated clothing and wash before reuse.

Storage:

P405 Store locked up.

Disposal:

P501 Dispose of contents/ container to an approved waste disposal plant.

Other hazards

None known.

SECTION 3. COMPOSITION/INFORMATION ON INGREDIENTS**Components**

Chemical name	CAS-No.	Concentration (% w/w)
Tributyl phosphate	126-73-8	55 - 65
Dibutylphenylphosphate	2528-36-1	20 - 30
Butyl diphenyl phosphate	2752-95-6	5 - 10
7-Oxabicyclo[4.1.0]heptane-3-carboxylic acid, 2-ethylhexyl ester	62256-00-2	< 10
butylated hydroxytoluene	128-37-0	1

SECTION 4. FIRST AID MEASURES

- If inhaled : Move to fresh air.
 If breathing is difficult, give oxygen.
 Consult a physician if necessary.
- In case of skin contact : Wash off immediately with plenty of water for at least 15 minutes.
 Get medical attention if symptoms occur.
 Wash contaminated clothing before reuse.
- In case of eye contact : In case of contact, immediately flush eyes with plenty of water for at least 15 minutes.
 Get medical attention if symptoms occur.
- If swallowed : Call a physician or poison control centre immediately.
 Do not induce vomiting without medical advice.
 Rinse mouth.
 Never give anything by mouth to an unconscious person.
- Most important symptoms and effects, both acute and delayed : Causes skin irritation.
 Suspected of causing cancer.

Skydrol® LD4 Fire Resistant Hydraulic Fluid

Version Revision Date: SDS Number: Date of last issue: 06/02/2015
 2.2 08/09/2016 15000093409 Date of first issue: 10/24/2013
 SDSUS / PRD / 0001

Wash thoroughly after handling.
 Wash contaminated clothing before reuse.
 Drain or remove substance from equipment prior to break-in or maintenance.
 Handle in accordance with good industrial hygiene and safety practice.

Conditions for safe storage : Store locked up.
 Keep container tightly closed in a dry and well-ventilated place.
 Keep in a cool place away from oxidizing agents.

SECTION 8. EXPOSURE CONTROLS/PERSONAL PROTECTION**Components with workplace control parameters**

Components	CAS-No.	Value type (Form of exposure)	Control parameters / Permissible concentration	Basis
Tributyl phosphate	126-73-8	TWA (Inhalable fraction and vapor)	5 mg/m ³	ACGIH
		TWA	0.2 ppm 2.5 mg/m ³	NIOSH REL
		TWA	5 mg/m ³	OSHA Z-1
		TWA	0.2 ppm 2.5 mg/m ³	OSHA P0
Dibutylphenylphosphate	2528-36-1	TWA	0.3 ppm	ACGIH
butylated hydroxytoluene	128-37-0	TWA (Inhalable fraction and vapor)	2 mg/m ³	ACGIH
		TWA	10 mg/m ³	NIOSH REL
		TWA	10 mg/m ³	OSHA P0

Hazardous components without workplace control parameters

Components	CAS-No.
7-Oxabicyclo[4.1.0]heptane-3-carboxylic acid, 2-ethylhexyl ester	62256-00-2

Engineering measures : Good general ventilation (typically 10 air changes per hour) should be used. Ventilation rates should be matched to conditions. If applicable, use process enclosures, local exhaust ventilation, or other engineering controls to maintain airborne levels below recommended exposure limits. If exposure limits have not been established, maintain airborne levels to an acceptable level.

Personal protective equipment

Respiratory protection : Use a properly fitted, particulate filter respirator complying with an approved standard if a risk assessment indicates this is necessary.

Skydrol® LD4 Fire Resistant Hydraulic Fluid

Version	Revision Date:	SDS Number:	Date of last issue: 06/02/2015
2.2	08/09/2016	150000093409	Date of first issue: 10/24/2013

SDSUS / PRD / 0001

Respirator selection, use, and maintenance must be in accordance with regulatory requirements, if applicable. If engineering controls do not maintain airborne concentrations below recommended exposure limits (where applicable) or to an acceptable level (in countries where exposure limits have not been established), an approved respirator must be worn.

Hand protection

Remarks : Wear suitable gloves. Please observe the instructions regarding permeability and breakthrough time which are provided by the supplier of the gloves. Also take into consideration the specific local conditions under which the product is used, such as the danger of cuts, abrasion, and the contact time. After contamination with product change the gloves immediately and dispose of them according to relevant national and local regulations.

Eye protection : Wear safety glasses with side shields (or goggles).

Skin and body protection : Wear suitable protective clothing.

Protective measures : Ensure that eye flushing systems and safety showers are located close to the working place.

SECTION 9. PHYSICAL AND CHEMICAL PROPERTIES

Appearance	: oily
Colour	: purple
Odour	: odourless
pH	: No data available
Melting point/range	: < -62 °C
Flash point	: 160 °C Method: Cleveland open cup
Vapour pressure	: 0.27 hPa (25 °C)
Relative density	: 1.004 - 1.014 (25 °C)
Viscosity	
Viscosity, kinematic	: < 2000 mm ² /s (-54 °C)
	11.15 mm ² /s (38 °C)
	3.83 mm ² /s (99 °C)

Skydrol® LD4 Fire Resistant Hydraulic Fluid

Version 2.2 Revision Date: 08/09/2016 SDS Number: 150000093409 Date of last issue: 06/02/2015
Date of first issue: 10/24/2013
SDSUS / PRD / 0001

SECTION 10. STABILITY AND REACTIVITY

Reactivity : None reasonably foreseeable.

Chemical stability : Stable under normal conditions.

Possibility of hazardous reactions : None known.

Conditions to avoid : None known.

Incompatible materials : Strong oxidizing agents

Hazardous decomposition products : Emits acrid smoke and fumes when heated to decomposition.

SECTION 11. TOXICOLOGICAL INFORMATION**Acute toxicity**

Not classified based on available information.

Product:

Acute oral toxicity : LD50 (Rat, Male and Female): 2,100 mg/kg

Acute inhalation toxicity : LC50 (Rat, male): > 5.8 mg/l
Exposure time: 4 h
Test atmosphere: dust/mist
Assessment: The substance or mixture has no acute inhalation toxicity
Remarks: (highest concentration tested)

Acute dermal toxicity : LD50 Dermal (Rabbit, Male and Female): > 3,160 mg/kg
Assessment: The substance or mixture has no acute dermal toxicity

Components:**Tributyl phosphate:**

Acute oral toxicity : LD50 Oral (Rat, Male and Female): 1,553 mg/kg
Method: Acute Oral Toxicity
Assessment: Harmful if swallowed.

Acute inhalation toxicity : LC50 (Rat, Male and Female): > 4.242 mg/l
Exposure time: 4 h
Test atmosphere: dust/mist
Assessment: The substance or mixture has no acute inhalation toxicity

Acute dermal toxicity : LD50 Dermal (Rabbit, Male and Female): > 3,100 mg/kg
Assessment: The substance or mixture has no acute dermal toxicity

Dibutylphenylphosphate:

Skydrol® LD4 Fire Resistant Hydraulic Fluid

Version 2.2 Revision Date: 08/09/2016 SDS Number: 150000093409 Date of last issue: 06/02/2015
Date of first issue: 10/24/2013
SDSUS / PRD / 0001

Acute oral toxicity : Acute toxicity estimate (Rat, Male and Female): 2,400 - 3,000 mg/kg
Assessment: Not classified

Acute inhalation toxicity : LCLo (Rat, Male and Female): > 5 mg/l
Exposure time: 4 h
Test atmosphere: dust/mist

LC50 (Rat, Male and Female): > 5 mg/l
Exposure time: 4 h
Test atmosphere: dust/mist
Assessment: Not classified

Acute dermal toxicity : LD50 Dermal (Rabbit, Male and Female): > 5,000 mg/kg
Assessment: Not classified

7-Oxabicyclo[4.1.0]heptane-3-carboxylic acid, 2-ethylhexyl ester:

Acute oral toxicity : LD50 Oral (Rat, Male and Female): 4,470 mg/kg

Acute dermal toxicity : LD50 Dermal (Rabbit, Male and Female): > 7,940 mg/kg

butylated hydroxytoluene:

Acute oral toxicity : LD50 Oral (Rat): > 6,000 mg/kg

Acute dermal toxicity : LD50 Dermal (Guinea pig): > 20,000 mg/kg

Skin corrosion/irritation

Causes skin irritation.

Product:

Species: Rabbit
Exposure time: 24 h
Assessment: irritating
Result: moderate irritation

Components:**Tributyl phosphate:**

Species: Rabbit
Exposure time: 4 h
Assessment: Causes skin irritation.
Method: Acute Dermal Irritation / Corrosion
Result: irritating

Dibutylphenylphosphate:

Species: Rabbit
Assessment: Not classified

Species: Humans
Exposure time: 24 h
Assessment: Not classified

7-Oxabicyclo[4.1.0]heptane-3-carboxylic acid, 2-ethylhexyl ester:

Species: Rabbit

Skydrol® LD4 Fire Resistant Hydraulic Fluid

Version 2.2 Revision Date: 08/09/2016 SDS Number: 150000093409 Date of last issue: 06/02/2015
Date of first issue: 10/24/2013
SDSUS / PRD / 0001

Exposure time: 24 h
Assessment: Not classified as hazardous.
Result: slight to moderate irritation

butylated hydroxytoluene:

Species: Rabbit
Exposure time: 24 h
Result: very slight

Serious eye damage/eye irritation

Not classified based on available information.

Product:

Species: Rabbit
Result: slight
Exposure time: 24 h
Assessment: Not classified

Components:**Tributyl phosphate:**

Species: Rabbit
Result: slight irritation
Exposure time: 24 h
Assessment: Not classified
Method: Acute Eye Irritation / Corrosion

Dibutylphenylphosphate:

Species: Rabbit
Result: slight
Assessment: Not classified

7-Oxabicyclo[4.1.0]heptane-3-carboxylic acid, 2-ethylhexyl ester:

Species: Rabbit
Result: slight irritation
Exposure time: 24 h
Assessment: Not classified

butylated hydroxytoluene:

Species: Rabbit
Result: none

Respiratory or skin sensitisation

Skin sensitisation: Not classified based on available information.
Respiratory sensitisation: Not classified based on available information.

Product:

Test Type: Human experience
Assessment: Not classified
Method: Human Repeat Insult Patch Test
Result: Does not cause skin sensitisation.

Components:

Skydrol® LD4 Fire Resistant Hydraulic Fluid

Version 2.2 Revision Date: 08/09/2016 SDS Number: 150000093409 Date of last issue: 06/02/2015
Date of first issue: 10/24/2013
SDSUS / PRD / 0001

Tributyl phosphate:

Test Type: Skin Sensitization
Species: Guinea pig
Assessment: Not classified
Result: Does not cause skin sensitisation.

Test Type: Skin Sensitization
Species: Humans
Assessment: Not classified
Result: Does not cause skin sensitisation.

Dibutylphenylphosphate:

Test Type: Human experience
Species: Humans
Assessment: Not classified
Result: non-sensitizing

7-Oxabicyclo[4.1.0]heptane-3-carboxylic acid, 2-ethylhexyl ester:

Test Type: Skin Sensitization
Species: Guinea pig
Result: May cause sensitisation by skin contact.

butylated hydroxytoluene:

Test Type: Skin sensitisation
Species: Guinea pig
Result: non-sensitizing

Germ cell mutagenicity

Not classified based on available information.

Product:

Genotoxicity in vitro : Test Type: Salmonella typhimurium assay (Ames test)
Metabolic activation: +/- activation
Result: negative

: Test Type: Mutagenicity - Mammalian
Metabolic activation: +/- activation
Method: In vitro Mammalian Chromosome Aberration Test
Result: negative

Components:**Tributyl phosphate:**

Genotoxicity in vitro : Test Type: Mutagenicity - Bacterial
Metabolic activation: +/- activation
Method: Bacterial Reverse Mutation Assay
Result: negative

: Test Type: Mutagenicity - Mammalian
Metabolic activation: +/- activation
Method: In vitro Mammalian Chromosome Aberration Test
Result: equivocal

Genotoxicity in vivo : Species: Rat (Male and Female)

Skydrol® LD4 Fire Resistant Hydraulic Fluid

Version 2.2 Revision Date: 08/09/2016 SDS Number: 150000093409 Date of last issue: 06/02/2015
Date of first issue: 10/24/2013
SDSUS / PRD / 0001

Application Route: oral: gavage
Method: Mammalian Bone Marrow Chromosome Aberration Test
Result: negative

Dibutylphenylphosphate:

Genotoxicity in vitro

- : Test Type: Salmonella typhimurium assay (Ames test)
Metabolic activation: +/- activation
Method: Bacterial Reverse Mutation Assay
Result: negative
- : Test Type: Mutagenicity - Mammalian
Metabolic activation: +/- activation
Method: In vitro Mammalian Cell Gene Mutation Test
Result: negative
- : Test Type: Chromosome aberration test in vitro
Metabolic activation: +/- activation
Method: In vitro Mammalian Chromosome Aberration Test
Result: negative
- : Test Type: Mutagenicity - Mammalian
Metabolic activation: - activation
Method: Genetic Toxicology: DNA Damage and Repair, Un-scheduled DNA Synthesis in Mammalian Cells In Vitro
Result: negative

Genotoxicity in vivo

- : Species: Rat (Male and Female)
Application Route: intraperitoneal injection
Result: negative

7-Oxabicyclo[4.1.0]heptane-3-carboxylic acid, 2-ethylhexyl ester:

Genotoxicity in vitro

- : Test Type: Salmonella typhimurium assay (Ames test)
Metabolic activation: +/- activation
Method: Bacterial Reverse Mutation Assay
Result: negative
- : Test Type: Mutagenicity - Mammalian
Metabolic activation: +/- activation
Method: In vitro Mammalian Chromosome Aberration Test
Result: equivocal
- : Test Type: Mutagenicity - Mammalian
Metabolic activation: +/- activation
Method: In vitro Mammalian Cell Gene Mutation Test
Result: negative

Genotoxicity in vivo

- : Species: Rat (Male and Female)
Application Route: intraperitoneal injection
Method: Mammalian Bone Marrow Chromosome Aberration Test
Result: equivocal

Skydrol® LD4 Fire Resistant Hydraulic Fluid

Version 2.2 Revision Date: 08/09/2016 SDS Number: 150000093409 Date of last issue: 06/02/2015
 Date of first issue: 10/24/2013
 SDSUS / PRD / 0001

Carcinogenicity

Suspected of causing cancer.

Components:**Tributyl phosphate:**

Species: Rat, (Male and Female)
 Application Route: Ingestion
 Method: EPA OTS 798.3300
 Remarks: Limited evidence of a carcinogenic effect.
 May cause cancer.

IARC

No component of this product present at levels greater than or equal to 0.1% is identified as probable, possible or confirmed human carcinogen by IARC.

OSHA

No component of this product present at levels greater than or equal to 0.1% is identified as a carcinogen or potential carcinogen by OSHA.

NTP

No component of this product present at levels greater than or equal to 0.1% is identified as a known or anticipated carcinogen by NTP.

Reproductive toxicity

Not classified based on available information.

Components:**Tributyl phosphate:**

Effects on fertility :
 Test Type: Two Generation Reproductive Toxicity Study
 Species: Rat
 Sex: Male and Female
 Application Route: Ingestion
 NOAEL: 225 mg/kg,
 Method: EPA OTS 798.4900

Effects on foetal development : Species: Rat
 Application Route: Oral
 750 mg/kg
 Method: EPA OTS 798.4900

Dibutylphenylphosphate:

Effects on fertility :
 Species: Rat
 Sex: Male and Female
 Application Route: Ingestion
 NOAEL: 5 mg/l,
 F1: Lowest observed adverse effect level 50 mg/kg,
 F2: Lowest observed adverse effect level 50 mg/kg,
 Method: EPA OTS 798.4900

Effects on foetal development : Species: Rat
 Application Route: oral (gavage)

Skydrol® LD4 Fire Resistant Hydraulic Fluid

Version 2.2 Revision Date: 08/09/2016 SDS Number: 150000093409 Date of last issue: 06/02/2015
Date of first issue: 10/24/2013
SDSUS / PRD / 0001

300 mg/kg
3 mg/kg

STOT - single exposure

Not classified based on available information.

Components:**Tributyl phosphate:**

Assessment: Based on available data, the classification criteria are not met.

Dibutylphenylphosphate:

Assessment: Not classified

STOT - repeated exposure

Not classified based on available information.

Components:**Tributyl phosphate:**

Assessment: Based on available data, the classification criteria are not met.

Dibutylphenylphosphate:

Exposure routes: inhalation (dust/mist/fume)

Target Organs: Respiratory system

Assessment: Not classified

Repeated dose toxicity**Product:**

Species: Rat, Male and Female

NOAEL: 40 mg/m³

Application Route: Inhalation

Exposure time: 28 days

Target Organs: Blood, Respiratory system

Remarks: Irritating to eyes and respiratory system.

Components:**Tributyl phosphate:**

Species: Mouse, Male and Female

NOEL: 75 mg/kg

Application Route: in feed

Exposure time: 90 days

Dibutylphenylphosphate:

Species: Rat, Male and Female

NOAEL: 5 mg/kg

LOAEL: 50 mg/kg

Application Route: oral (feed)

Exposure time: 90 days

Species: Rat, Male and Female

NOAEC: 5 mg/m³

Application Route: Inhalation

Skydrol® LD4 Fire Resistant Hydraulic Fluid

Version 2.2 Revision Date: 08/09/2016 SDS Number: 150000093409 Date of last issue: 06/02/2015
Date of first issue: 10/24/2013
SDSUS / PRD / 0001

Exposure time: 90 days

Species: Rabbit, Male and Female
No observed adverse effect level: 100 mg/kg bw/day
Application Route: Dermal Study
Exposure time: 21 d

Aspiration toxicity

Not classified based on available information.

Product:

Not applicable

Components:

7-Oxabicyclo[4.1.0]heptane-3-carboxylic acid, 2-ethylhexyl ester:

Not applicable

Experience with human exposure**Product:**

Inhalation : Remarks: None known.
Skin contact : Remarks: Causes skin irritation.
Eye contact : Remarks: Contact with the eyes may be very painful but does not cause damage.
Ingestion : Remarks: None known.

SECTION 12. ECOLOGICAL INFORMATION**Ecotoxicity****Product:**

Toxicity to fish : LC50 (Oncorhynchus mykiss (rainbow trout)): 5.2 mg/l
Exposure time: 96 h
Toxicity to daphnia and other aquatic invertebrates : LC50 (Daphnia magna (Water flea)): 5.8 mg/l
Exposure time: 48 h
Toxicity to algae : EC50 (Selenastrum capricornutum (green algae)): 8.2 mg/l
Exposure time: 96 h

Components:**Tributyl phosphate:**

Toxicity to fish : LC50 (Oncorhynchus mykiss (rainbow trout)): 4.2 mg/l
Exposure time: 96 h
Toxicity to daphnia and other : EC50 (Daphnia magna (Water flea)): 1.8 mg/l

Skydrol® LD4 Fire Resistant Hydraulic Fluid

Version 2.2 Revision Date: 08/09/2016 SDS Number: 150000093409 Date of last issue: 06/02/2015
 Date of first issue: 10/24/2013
 SDSUS / PRD / 0001

aquatic invertebrates	Exposure time: 48 h
Toxicity to algae	: EC50 (Desmodesmus subspicatus (Scenedesmus subspicatus)): 1.1 mg/l Exposure time: 72 h
Toxicity to fish (Chronic toxicity)	: NOEC (Oncorhynchus mykiss (rainbow trout)): 0.82 mg/l Exposure time: 95 d 1.7 mg/l
Toxicity to daphnia and other aquatic invertebrates (Chronic toxicity)	: NOEC (Daphnia magna (Water flea)): 1.3 mg/l Exposure time: 21 d
Dibutylphenylphosphate:	
Toxicity to fish	: LL50 (Cyprinus carpio (Carp)): 1.8 mg/l Exposure time: 96 h
Toxicity to daphnia and other aquatic invertebrates	: EC50 (Daphnia magna (Water flea)): 1.4 mg/l Exposure time: 48 h
Toxicity to algae	: EL50 (Selenastrum capricornutum (green algae)): 9.6 mg/l Exposure time: 72 h Method: EL50 method of the water accommodated fraction (W.A.F.) NOELR (Selenastrum capricornutum (green algae)): 3.5 mg/l Exposure time: 72 h Method: EL50 method of the water accommodated fraction (W.A.F.)
Toxicity to fish (Chronic toxicity)	: NOEC (Oncorhynchus mykiss (rainbow trout)): > 0.11 mg/l Exposure time: 60 d
Toxicity to daphnia and other aquatic invertebrates (Chronic toxicity)	: NOEC (Daphnia magna (Water flea)): 0.106 mg/l Exposure time: 21 d
butylated hydroxytoluene:	
Toxicity to fish	: LC50 (Fish): 0.199 mg/l Exposure time: 96 h
Toxicity to daphnia and other aquatic invertebrates	: EC50 (Daphnia (water flea)): 0.48 mg/l Exposure time: 48 h
Toxicity to algae	: EC50 (Chlorella pyrenoidosa (aglae)): 0.758 mg/l Exposure time: 96 h

Persistence and degradability**Product:**

Biochemical Oxygen Demand (BOD) : Remarks: not determined

Skydrol® LD4 Fire Resistant Hydraulic Fluid

Version 2.2 Revision Date: 08/09/2016 SDS Number: 150000093409 Date of last issue: 06/02/2015
Date of first issue: 10/24/2013
SDSUS / PRD / 0001

Chemical Oxygen Demand (COD) : Remarks: not determined

Components:**Tributyl phosphate:**

Biodegradability : Result: Readily biodegradable

Dibutylphenylphosphate:

Biodegradability : Method: Ready Biodegradability: Manometric Respirometry Test

Remarks: Readily biodegradable

Method: Ready Biodegradability: Modified MITI Test (I)

Remarks: Not readily biodegradable.

7-Oxabicyclo[4.1.0]heptane-3-carboxylic acid, 2-ethylhexyl ester:

Biodegradability : Concentration: 100 mg/l
Method: Ready Biodegradability: Modified MITI Test (I)
Remarks: Readily biodegradable

Bioaccumulative potential**Components:****Tributyl phosphate:**

Bioaccumulation : Species: Cyprinus carpio (Carp)
Bioconcentration factor (BCF): 20
Exposure time: 56 d
Method: OECD Test Guideline 305

Bioconcentration factor (BCF): 35

Exposure time: 38 d

Partition coefficient: n-octanol/water : Pow: 10,100

Dibutylphenylphosphate:

Bioaccumulation : Species: Cyprinus carpio (Carp)
Bioconcentration factor (BCF): 35
Method: OECD Test Guideline 305

Mobility in soil

No data available

Other adverse effects**Product:**

Ozone-Depletion Potential :

Regulation: 40 CFR Protection of Environment; Part 82 Protection of Stratospheric Ozone - CAA Section 602 Class I Substances

Skydrol® LD4 Fire Resistant Hydraulic Fluid

Version Revision Date: SDS Number: Date of last issue: 06/02/2015
2.2 08/09/2016 150000093409 Date of first issue: 10/24/2013
SDSUS / PRD / 0001

Remarks: This product neither contains, nor was manufactured with a Class I or Class II ODS as defined by the U.S. Clean Air Act Section 602 (40 CFR 82, Subpt. A, App.A + B).

SECTION 13. DISPOSAL CONSIDERATIONS**Disposal methods**

Waste from residues : This product meets the criteria for a synthetic used oil under the U.S. EPA Standards for the Management of Used Oil (40 CFR 279). Those standards govern recycling and disposal in lieu of 40 CFR 260 -272 of the Federal hazardous waste program in states that have adopted these used oil regulations. Consult your attorney or appropriate regulatory official to be sure these standards have been adopted in your state. Recycle or burn in accordance with the applicable standards. Dispose of in accordance with local regulations.

SECTION 14. TRANSPORT INFORMATION**International Regulation****IATA-DGR**

Not regulated as a dangerous good

IMDG-Code

Not regulated as a dangerous good

Transport in bulk according to Annex II of MARPOL 73/78 and the IBC Code

Not applicable for product as supplied.

National Regulations**49 CFR**

Not regulated as a dangerous good

SECTION 15. REGULATORY INFORMATION**EPCRA - Emergency Planning and Community Right-to-Know Act****SARA 311/312 Hazards**

: Acute Health Hazard
Chronic Health Hazard

SARA 302

: No chemicals in this material are subject to the reporting requirements of SARA Title III, Section 302.

SARA 313

: This material does not contain any chemical components with known CAS numbers that exceed the threshold (De Minimis) reporting levels established by SARA Title III, Section 313.

Clean Air Act

Skydrol® LD4 Fire Resistant Hydraulic Fluid

Version Revision Date: SDS Number: Date of last issue: 06/02/2015
 2.2 08/09/2016 150000093409 Date of first issue: 10/24/2013
 SDSUS / PRD / 0001

Association; IBC - International Code for the Construction and Equipment of Ships carrying Dangerous Chemicals in Bulk; IC50 - Half maximal inhibitory concentration; ICAO - International Civil Aviation Organization; IECSC - Inventory of Existing Chemical Substances in China; IMDG - International Maritime Dangerous Goods; IMO - International Maritime Organization; ISHL - Industrial Safety and Health Law (Japan); ISO - International Organisation for Standardization; KECI - Korea Existing Chemicals Inventory; LC50 - Lethal Concentration to 50 % of a test population; LD50 - Lethal Dose to 50% of a test population (Median Lethal Dose); MARPOL - International Convention for the Prevention of Pollution from Ships; MSHA - Mine Safety and Health Administration; n.o.s. - Not Otherwise Specified; NFPA - National Fire Protection Association; NO(A)EC - No Observed (Adverse) Effect Concentration; NO(A)EL - No Observed (Adverse) Effect Level; NOELR - No Observable Effect Loading Rate; NTP - National Toxicology Program; NZIoC - New Zealand Inventory of Chemicals; OECD - Organization for Economic Co-operation and Development; OPPTS - Office of Chemical Safety and Pollution Prevention; PBT - Persistent, Bioaccumulative and Toxic substance; PICCS - Philippines Inventory of Chemicals and Chemical Substances; (Q)SAR - (Quantitative) Structure Activity Relationship; RCRA - Resource Conservation and Recovery Act; REACH - Regulation (EC) No 1907/2006 of the European Parliament and of the Council concerning the Registration, Evaluation, Authorisation and Restriction of Chemicals; RQ - Reportable Quantity; SADT - Self-Accelerating Decomposition Temperature; SARA - Superfund Amendments and Reauthorization Act; SDS - Safety Data Sheet; TCSI - Taiwan Chemical Substance Inventory; TSCA - Toxic Substances Control Act (United States); UN - United Nations; UNRTDG - United Nations Recommendations on the Transport of Dangerous Goods; vPvB - Very Persistent and Very Bioaccumulative

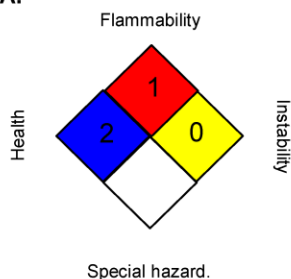
Further information**NFPA:****HMIS III:**

HEALTH	2*
FLAMMABILITY	1
PHYSICAL HAZARD	0

0 = not significant, 1 = Slight,
 2 = Moderate, 3 = High
 4 = Extreme, * = Chronic

Sources of key data used to compile the Safety Data Sheet : www.EastmanAviationSolutions.com
 Revision Date : 08/09/2016

The information provided in this Safety Data Sheet is correct to the best of our knowledge, information and belief at the date of its publication. The information given is designed only as a guidance for safe handling, use, processing, storage, transportation, disposal and release and is not to be considered a warranty or quality specification. The information relates only to the specific material designated and may not be valid for such material used in combination with any other materials or in any process, unless specified in the text.

Skydrol® LD4 Fire Resistant Hydraulic Fluid

Version	Revision Date:	SDS Number:	Date of last issue: 06/02/2015
2.2	08/09/2016	150000093409	Date of first issue: 10/24/2013

SDSUS / PRD / 0001

US / EN



APPENDIX VIII

Instrument Certification Notice



Instrument Certification Notice

The gauge Certificates of Calibration supplied for the gauge(s) on this unit contain the calibration data for the actual instrument calibrated, along with the calibration date of the **STANDARD** used to perform the calibration check.

The due date for re-calibration of the instrument should be based upon the date the instrument was placed in service in your facility. Re-calibration should be done on a periodic basis as dictated by the end user's quality system or other overriding requirements.

Note that Tronair, Inc. does not supply certificates of calibration on flow meters or pyrometers unless requested at the time of placed order. These instruments are considered reference indicators only and are not critical to the test(s) being performed on the aircraft.