

Model: 8654-010
30 Ton (27 Metric Ton)
Tripod Jack

03/2018 – Rev. 01

REVISION
01

DATE
03/2018

TEXT AFFECTED
Original release

TABLE OF CONTENTS

	<u>PAGE</u>
1.0 PRODUCT INFORMATION	1
1.1 DESCRIPTION.....	1
1.2 MODEL & SERIAL NUMBER.....	1
1.3 MANUFACTURER	1
1.4 SPECIFICATIONS	1
2.0 SAFETY INFORMATION	1
2.1 USAGE AND SAFETY INFORMATION	1
2.2 PRODUCT SAFETY	1
3.0 PREPARATION PRIOR TO FIRST USE	2
3.1 GENERAL INSPECTION	2
3.2 SYSTEM BLEED PROCEDURE	2
4.0 TRAINING	2
4.1 TRAINING REQUIREMENTS	2
4.2 TRAINING PROGRAM	2
4.3 OPERATOR TRAINING	2
5.0 OPERATION	2
5.1 PRE-OPERATION PROCEDURE.....	2
5.2 LIFTING PROCEDURE	2
5.3 LOWERING PROCEDURE	3
5.4 RELIEF VALVE	3
6.0 TROUBLE SHOOTING	4
7.0 MAINTENANCE.....	5
7.1 SHOP AIDS KITS AVAILABLE	5
7.2 OVERHAUL KITS AVAILABLE	5
8.0 PROVISION OF SPARES.....	5
8.1 SOURCE OF SPARE PARTS.....	5
8.2 RECOMMENDED SPARE PARTS LISTS	5
9.0 IN SERVICE SUPPORT.....	5
10.0 GUARANTEES/LIMITATION OF LIABILITY	6
11.0 APPENDICES	6

This product can not be modified without the written approval of Tronair, Inc. Any modifications done without written approval voids all warranties and releases Tronair, Inc., its suppliers, distributors, employees, or financial institutions from any liability from consequences that may occur. Only Tronair OEM replacement parts shall be used.

1.0 PRODUCT INFORMATION

1.1 DESCRIPTION

30 Ton (27 Metric Ton) Tripod Jack

1.2 MODEL & SERIAL NUMBER

Reference nameplate on unit

1.3 MANUFACTURER

Columbus**Jack**/Regent
1 Air Cargo Pkwy East
Swanton, Ohio 43558 USA

Telephone: 614.443.7492
Fax: 614.444.9337
E-mail: sales@columbusjack.com
Website: www.columbusjack.com

1.4 SPECIFICATIONS

Capacity 30 Ton (27 Metric Ton)
Minimum Height 125 in (317.5 cm)
Hydraulic Lift 44 in (111.76 cm)
Screw Extension 15 in (38.1 cm)
Maximum Height 184 in (467.36 cm)
Estimated Weight 1575 lbs (714.4 kg)
Operating Pressure 1640 psi (113 bar)
Relief Valve Pressure 1804psi (124.4 bar)
Reservoir Capacity 8.6 gal (32.6 l)

2.0 SAFETY INFORMATION

2.1 USAGE AND SAFETY INFORMATION

To insure safe operations please read the following statements and understand their meaning. Also refer to your equipment manufacturer's manual for other important safety information. This manual contains safety precautions which are explained below. Please read carefully.



WARNING! — Warning is used to indicate the presence of a hazard that **can cause severe personal injury, death, or substantial property damage** if the warning notice is ignored.

CAUTION! — Caution is used to indicate the presence of a hazard that **will or can cause minor personal injury or property damage** if the caution notice is ignored.

2.2 PRODUCT SAFETY

Make sure all personnel involved with this jack read and understand these instructions before using.



CAUTION!

DO NOT exceed 5 mph (8 kph) when towing jack.



WARNING!

Each jack is operated independently and aircraft must be raised evenly to provide stability. Failure to use safe jacking practices may result in equipment damage and injury to personnel. Personnel not involved in jacking the aircraft must remain clear of the immediate area. Other work should not be performed until jacking is completed and aircraft is stabilized. Do not work under suspended loads unless required. Failure to follow strict safety precautions may result in equipment damage and injury or death to personnel. When jacking operations are completed and aircraft is stabilized, necessary personnel may complete required maintenance actions under aircraft.

The jack is designed to lift only vertical loads with a maximum weight of 30 ton (27 metric ton). DO NOT use jack for lifts exceeding the weight or design limits. Failure to comply can result in injury or death to personnel and/or severe damage to the jack and aircraft.

Casters will carry only the weight of the jack. Ensure casters compress under aircraft load to prevent injury to personnel and equipment damage.

3.0 PREPARATION PRIOR TO FIRST USE

3.1 GENERAL INSPECTION

If the jack is crated, uncrate and remove shipping straps or packing material. Inspect for physical damage and missing parts.

3.2 SYSTEM BLEED PROCEDURE

1. Raise ram approximately 6 in (15.2 cm) with hand pump.
2. Open release valve on hand pump.
3. If ram fails to raise, repeat steps 1 thru 2 until all air is removed and ram is able to raise upon using hand pump.

4.0 TRAINING

4.1 TRAINING REQUIREMENTS

The employer of the operator is responsible for providing a training program sufficient for the safe operation of the unit.

4.2 TRAINING PROGRAM

The employer provided operator training program should cover safety procedures concerning use of the unit in and around the intended aircraft at the intended aircraft servicing location.

4.3 OPERATOR TRAINING

The operator training should provide the required training for safe operation of the unit.

NOTE: Maintenance and Trouble Shooting are to be performed by a skilled and trained technician.

5.0 OPERATION

5.1 PRE-OPERATION PROCEDURE

1. Perform visual inspection, by checking for oil leakage.
2. Check for loose, damaged or missing parts.
3. Check oil level.

5.2 LIFTING PROCEDURE

1. Extension screw should be screwed down and ram should be fully retracted.
2. Verify that caster locks are unlocked.
3. Position jack under load lifting point. Verify that jack footpads will rest on level concrete foundation. If not on concrete, it may be necessary to place a flat steel plate under footpads to distribute jack bearing pressure.
4. Unscrew the screw extension as required.
5. Close release valve.
6. Operate pump to extend ram until contact is made with load lift point and extension screw adapter, with no pressure applied.
7. Rotate jack approximately 15° in any direction to minimize jack movement when load is applied to casters.
8. Operate pump to extend ram until the footpads contact the ground.
9. Extend ram to desired height. Set locknut.



WARNING!

Maintain approximately 1 in (2.54 cm) clearance between locknut and cylinder head, manually moving if necessary, during raising and lowering of ram.

10. Screw locknut down against cylinder head and ram to mechanically secure the lifted load.
11. Open release valve to release hydraulic pressure

5.0 Maintenance continued on following page.

5.0 OPERATION *(continued)*

5.3 LOWERING PROCEDURE

1. Close release valve.
2. Operate pump to raise ram until locknut is free to rotate.
3. Slowly open jack release valve and allow ram to fully retract.

NOTE: *Speed of lowering is controlled by how far release valve is open.*



WARNING!

Maintain approximately 1 in (2.54 cm) clearance between locknut and cylinder head, manually moving if necessary, during raising and lowering of ram.

4. Lower extension screw completely.
5. Ensure two (2) trailing casters are set in the proper position and locks are engaged before towing.

5.4 RELIEF VALVE

1. Position jack under a jack tester. Partially extend the ram.
2. Remove pipe plus from under the pump piston.
3. Set the relief valves at 31.5 – 33 tons as described in RJM 117. (See Appendix).



WARNING!

Use care not to set valve more than 10% above rated capacity.

DO NOT exceed 33 tons.

4. Reinstall plugs.

6.0 TROUBLE SHOOTING

If operational troubles are encountered, refer to the Trouble Shooting Chart which lists the most commonly occurring problems and gives information which will facilitate location of trouble source and determination of remedial action.

TROUBLE	PROBABLE CAUSE	REMEDY
External fluid leakage at manual pump piston or pump body	Damaged backup rings, packing, piston or pump body	Remove affected piston and inspect piston and pump body for damage. Replace defective parts. Replace removed packing and backup ring
External fluid leakage at ram	Damaged backup ring, packing or inner cylinder wall	Withdraw ram as a unit from cylinder. Inspect for defective parts. Replace removed packing and backup ring
Jack fails to lift rated load with operation of manual pump	Incomplete closure of release valve	Fully tighten release valve
	Obstructed fluid suction passages	Remove pump rocker and link details. Unscrew pump body; remove assembled valve assembly. Blow passage clear with compressed air; flush with clean fluid, reassemble and fill with hydraulic fluid
	Low fluid level	Fill to correct fluid level
	By-pass valve improperly adjusted	Test and adjust by-pass valve.
	Broken compression spring	Remove pump rocker and link details, unscrew pump body. Remove and replace defective valve assembly; test and adjust by-pass valve
	Airlock or vacuum in reservoir due to clogged breather passage in air vent	Remove air vent assembly and clear the obstruction
Rams will not fully elevate when manual pump is operated	Low fluid level	Fill to correct fluid level
	Leaking pump discharge valve or leaking pump suction valve	Remove pump rocker and link details, unscrew pump body. Remove and replace defective valve assembly; test and adjust by-pass valve
Rams will not support load after manual pump up	Leaking pump discharge valve	Remove the check valve and verify holding capacity on test stand. If leakage occurs, replace
	Pressure leakage past release valve ball	Remove release valve, inspect ball and ball seat in pump block. Replace defective parts
Rams elevate and fall with each manual pump stroke	Incomplete closure of release valve	Fully tighten release valve
	Check valve next to cylinder and in hand pump, both are defective	Remove and replace defective check valve
	Pressure leakage past release valve ball	Remove release valve. Inspect ball and ball seat in pump block. Replace defective parts
Manual pump inoperative or difficult to operate	Air lock or vacuum in reservoir due to clogged breather passage in air vent assembly	Remove air vent assembly and clear obstruction
Pump-up satisfactory, but pump pressure fails to by-pass at maximum ram extension or with overload applied	By-pass valve improperly adjusted	Test and adjust by-pass valve
	Defective or jammed by-pass valve spring, rivet or ball	Remove pump rocker and link details, unscrew pump body. Remove and replace defective valve assembly; test and adjust by-pass valve

7.0 MAINTENANCE

There are no special maintenance instructions for this jack.

7.1 SHOP AIDS KITS AVAILABLE

Ram Removal Tool 9380-1
Adjuster Assembly 915-EB

7.2 OVERHAUL KITS AVAILABLE

Seal Kit KC8654
Repair Kit KD8864

8.0 PROVISION OF SPARES

8.1 SOURCE OF SPARE PARTS

Spare parts may be obtained from the manufacturer:

Columbus**Jack**/Regent
1 Air Cargo Pkwy East
Swanton, Ohio 43558 USA

Telephone: 614.443.7492
Fax: 614.444.9337
E-mail: sales@columbusjack.com
Website: www.columbusjack.com

8.2 RECOMMENDED SPARE PARTS LISTS

Reference the following page(s) for Replacement Parts and Kits available.

9.0 IN SERVICE SUPPORT

Contact Columbus Jack. for technical services and information. See Section 1.3 – Manufacturer.

10.0 GUARANTEES/LIMITATION OF LIABILITY

1. ColumbusJACK Corporation, (Seller) warrants each new product of its manufacture to be free from defects in material or workmanship, under proper, reasonable and normal use and service, and for a period of twelve (12) months after date of shipment from Seller's Swanton, OH. USA facility.
2. Where Buyer claims an alleged defect in material or workmanship and so advises Seller in writing within ten (10) days after discovery thereof, then and in such event, Buyer shall return said equipment, transportation prepaid, to the Seller, provided such return is timely and within twelve (12) months form date of original shipment. This warranty and liability of the Seller is expressly limited solely to replacement of repair of defective parts or goods, and return at Buyer's expense to Seller after find by Seller the product was defective prior to original shipment or, at the option of Seller, to making refund to Buyer of the purchase price for said product.
3. It is further expressly understood and agreed that:
 - a. THERE IS NO WARRANTY, representation of condition OF ANY KIND, express or implied, (INCLUDING NO WARRANTY OF MERCHANT-ABILITY OR OF FITNESS) EXCEPT THAT THE MATERIAL SHALL BE OF THE QUALITY SPECIFIED HEREIN, and none shall be implied by law. Except as otherwise provided herein, quality shall be in accordance with seller's specifications. Final determination of the material for the use contemplated by Buyer is the sole responsibility of Buyer and Seller shall have no responsibility in connection with such suitability, and
 - b. The Buyer's sole and exclusive remedy shall be repair or replacement of defective parts by the Seller. Should the goods, in the judgment of Seller, preclude the remedying of the warranted defects by repair or replacement, the buyer's sole and exclusive remedy shall be the refund of the purchase price, and
 - c. Seller shall not be liable for prospective profits or special, indirect or consequential damages, nor shall any recovery of any kind against Seller be greater in amount than the purchase price of the specific material sold and causing the alleged loss, damage or injury. Buyer assumes all risk and liability for loss, damage or injury to persons or property of Buyer or others arising out of use or possession of any product or part sold hereunder, and
 - d. The Seller shall in no way be deemed or held to be obligated, liable or accountable upon or for any guarantees or warranties, express or implied, or created by statute or by operation of law or otherwise, in any manner of form beyond its express agreement above set forth, and
 - e. No warranty herein shall apply to any product which shall have been repaired or altered, unless such alteration or repair has been made by Seller or where, after return to and inspection by Seller, the product is found by Seller to have been subject to misuse, negligence or accident, and
 - f. No warranty of any nature is made by Seller as to any component forming a part of the product sold and Buyer shall receive only such warranties offered by such other manufacturer pertinent to such component, and
 - g. Seller does not assume nor does Seller authorize any other person to assume for it any other liability or make any warranty in connection with the sale of its products.

The obligations of ColumbusJACK expressly stated herein are in lieu of all other warranties or conditions expressed or implied. **Any unauthorized modification of the ColumbusJACK products or use of the ColumbusJACK products in violations of cautions and warnings in any manual (including updates) or safety bulletins published or delivered by ColumbusJACK will immediately void any warranty, express or implied and ColumbusJACK disclaims any and all liability for injury (WITHOUT LIMITATION and including DEATH), loss or damage arising from or relating to such misuse.**

11.0 APPENDICES

APPENDIX I Routine Jack Maintenance Bulletins

Parts List

When ordering replacement parts/kits, please specify model, serial number and color of your unit.

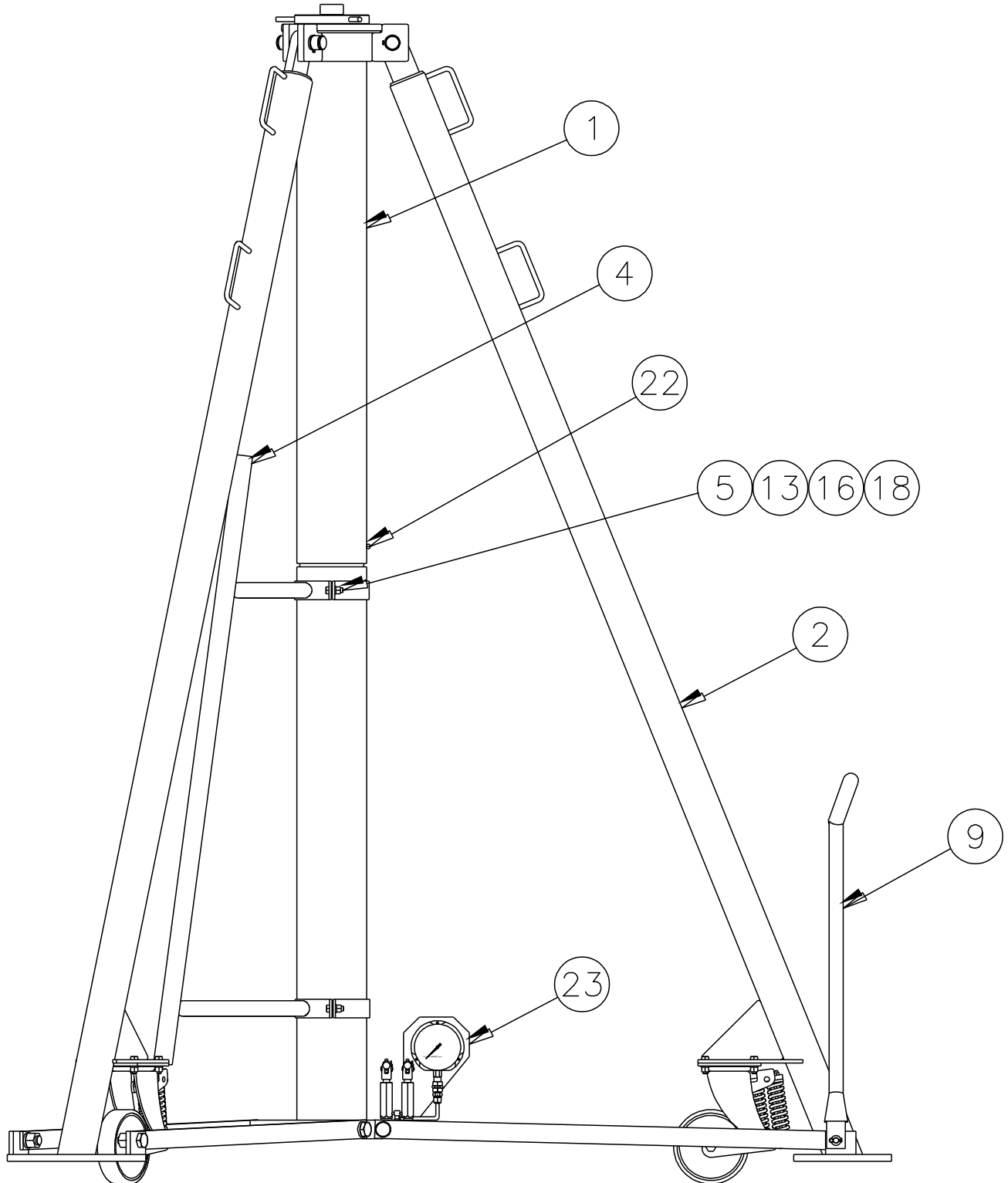

Parts List

When ordering replacement parts/kits, please specify model, serial number and color of your unit.

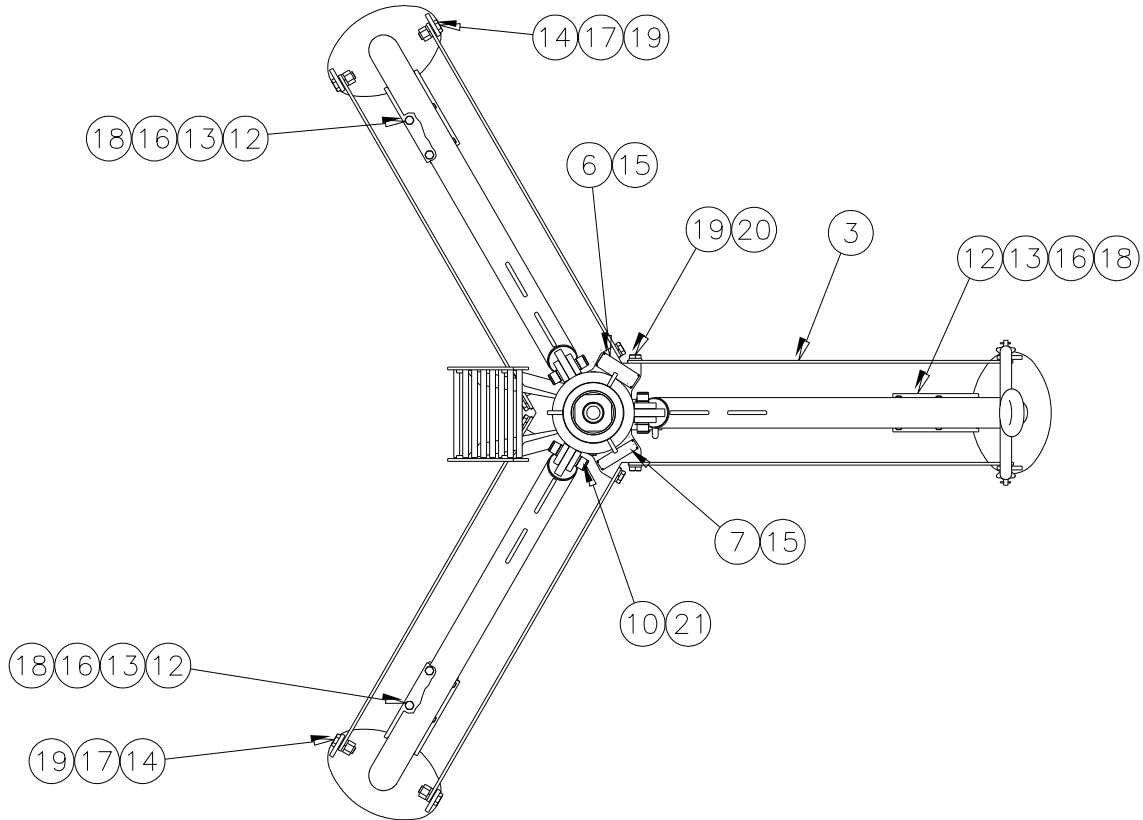

Item	Part Number	Description	Qty
1	8654-C	Hydraulic Cylinder Assembly	1
2	8654-8	Leg	3
3	8654-9	Tie Bar	6
4	8654-10	Ladder	1
5	8654-11	Clamp	2
6	915-543	Nameplate	1
7	915-545	Placard, Operating Procedure	1
9	2955-D	Towbar Assembly	1
10	8556-10	Pin	3
11	915-143U	Double Pump Handle, (Not Shown)	1
12	916-AL	Swivel Caster Assembly	3
13	372-20120	Hex Head Cap Screw	12
14	372-30180	Hex Head Cap Screw	4
15	450A6984	Drive Screw	8
16	333-52000	Hex Nut	12
17	333-53100	Hex Nut	4
18	346-10032	Lockwasher	12
19	346-10064	Lockwasher	10
20	372-30120	Hex Head Cap Screw	6
21	450A5779	Retaining Ring	6
22	488-00002	Pipe Plug	1
23	8654-G	Pressure Gauge Assembly (Optional)	1

Parts List

When ordering replacement parts/kits, please specify model, serial number and color of your unit.

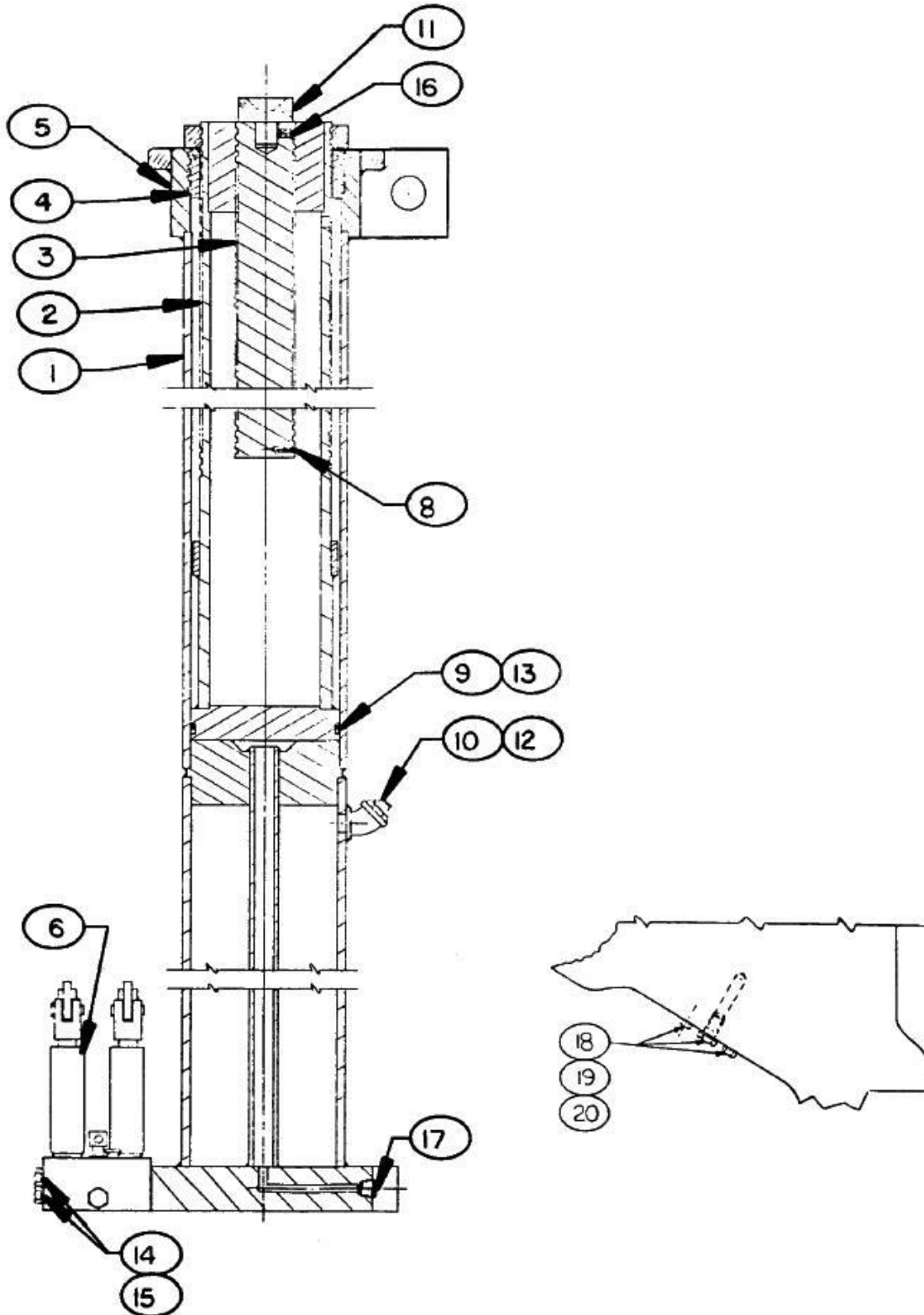

Parts List

When ordering replacement parts/kits, please specify model, serial number and color of your unit.

Item	Part Number	Description	Qty
	8654-C	Hydraulic Cylinder Assembly; consists of:	
2	8654-2	Ram	1
3	8654-3	Screw Extension	1
4	8654-4	Bushing	1
5	8654-5	Locknut	1
6	915-AP-1	Pump, Double	1
8	311-12080	Set Screw, Cup Point	1
9	916-44-6.350	Backup Ring	1
10	916-208	Filler Plug	1
11	916-182	Socket	1
12	485-51612	Reducer	1
13	611-43843	O-Ring	1
14	372-20360	Hex Head Cap Screw	3
15	346-10032	Lockwasher	3
16	311-16041	Set Screw, Flat Poin	1
17	488-00006	Pipe Plug	1
18	450A5685	Lock-O-Seal	1
19	372-20060	Hex Head Cap Screw	1
20	372-14040	Hex Head Cap Screw	2

Parts List

When ordering replacement parts/kits, please specify model, serial number and color of your unit.

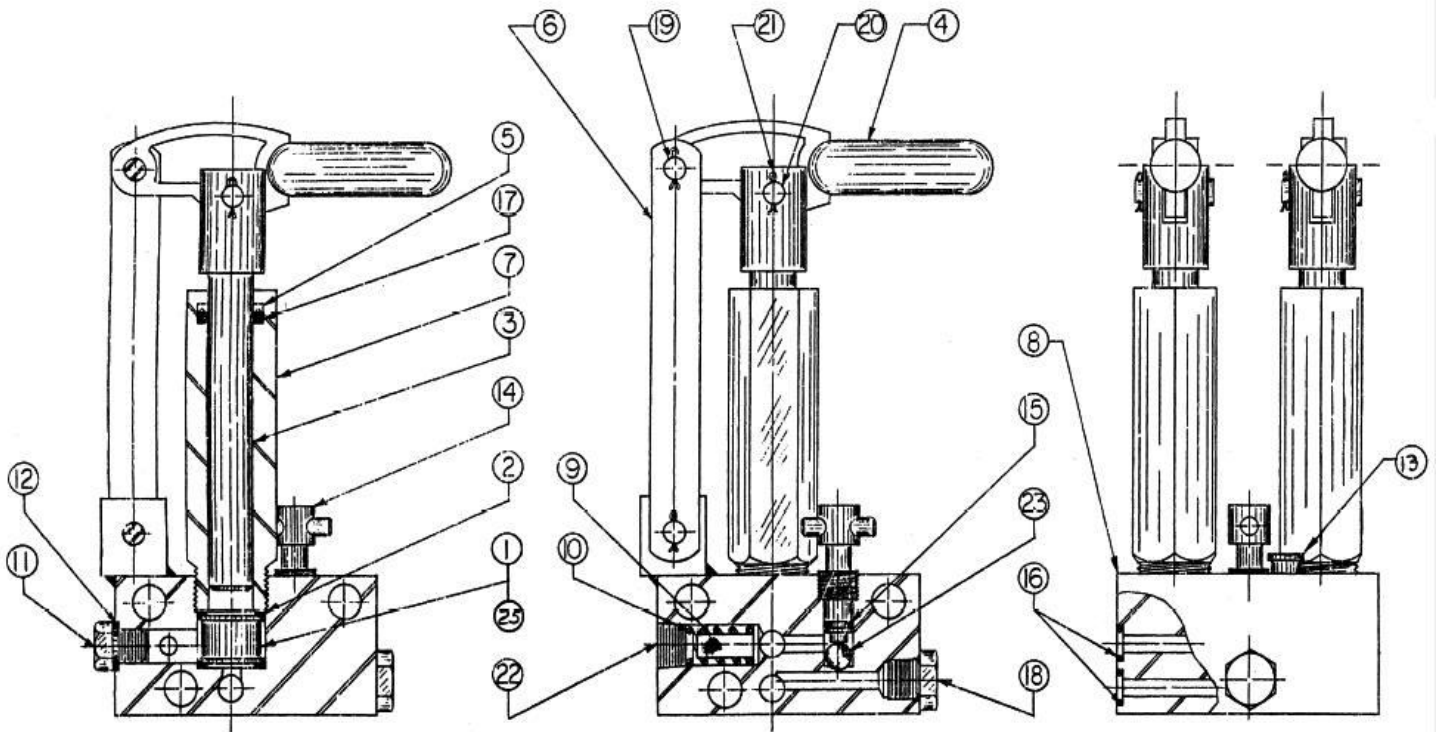
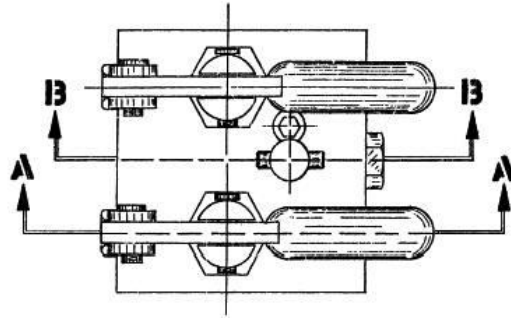

SECTION A-A

SECTION B-B

Parts List

When ordering replacement parts/kits, please specify model, serial number and color of your unit.

Item	Part Number	Description	Qty
	915-AP-1	Pump Assembly ; consists of:	
1	915-16A-3	Valve Assembly	2
2	915-17	Gasket, Valve	4
3	915-74C	Piston, Pump	2
4	915-75	Rocker Arm	2
5	915-127.13	Backup Ring	2
6	915-151.42	Link, Pump	2
7	915-179	Body, Pump	2
8	915-184	Block Assembly, Double Pump	1
9	916-7	Oil Screen	1
10	916-10	Spring	1
11	916-21	Plug, Valve	2
12	916-22	Gasket	2
13	916-35	Screw, Release Valve Lock	1
14	916-37	Release Valve Assembly	1
15	611-01101	O-Ring	1
16	611-01201	O-Ring	2
17	611-11511	O-Ring	2
18	488-30006	Hex Head Plug	1
19	915-15.25	Clevis Pin	4
20	915-15.33	Clevis Pin	2
21	322-03240	Cotter Pin	6
22	488-00006	Pipe Plug	1
23	216-1-24	Ball	1
1	915-16A-3	Valve Assembly	2
2	915-17	Gasket, Valve	4

Parts List

When ordering replacement parts/kits, please specify model, serial number and color of your unit.

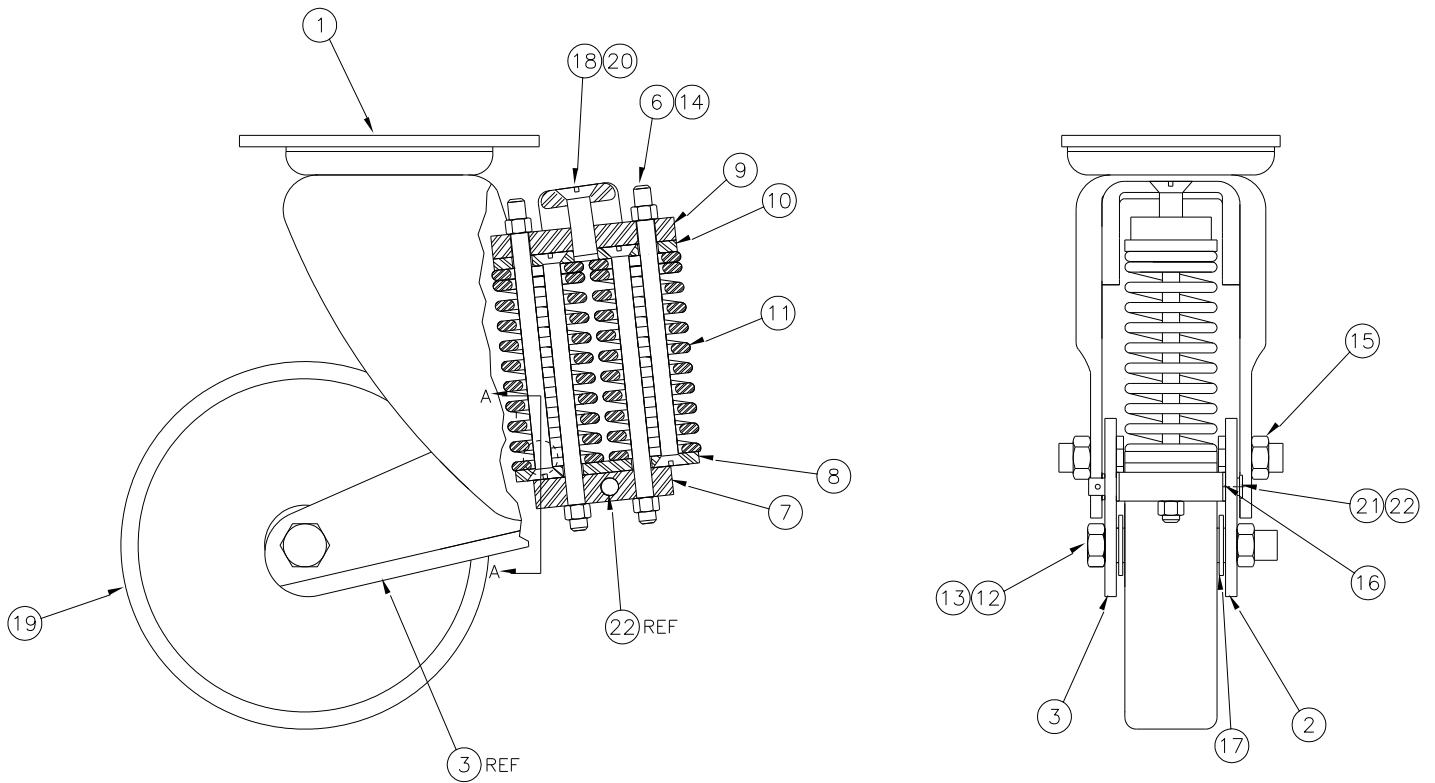

SOME ITEMS REMOVED FOR CLARITY

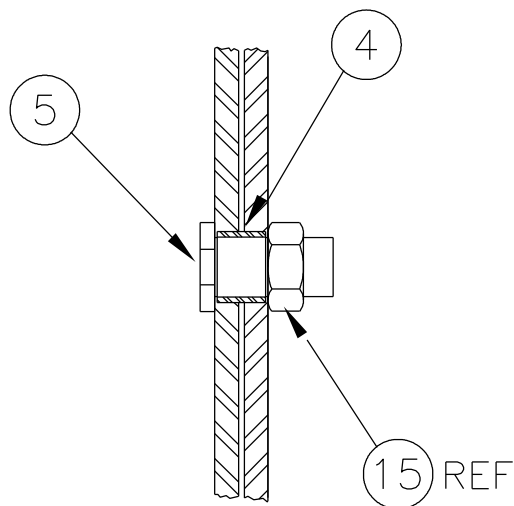

SECTION A-A

Parts List

When ordering replacement parts/kits, please specify model, serial number and color of your unit.

Item	Part Number	Description	Qty
	916-AL	Swivel Caster Assembly; consists of:	
1	916-134	Caster Frame	1
2	916-141L	Pivot Wheel Arm, Left	1
3	916-141R	Pivot Wheel Arm, Right	1
4	916-167	Bushing	2
5	916-168	Pin, Caster Hinge	2
6	916-171-6.25	Bolt, Spring Guide	4
7	916-177	Plate, Spring Guide	1
8	916-178	Guide Plate, Lower Spring	1
9	916-179	Top Plate, Caster Spring	1
10	916-180	Guide Plate, Upper Spring	1
11	916-184-1	Spring	2
12	333-32400	Hex Locknut	1
13	375-24300	Hex Head Cap Screw	1
14	333-51600	Hex Nut	4
15	450A7012	Hex Locknut	2
16	AN960-616	Flat Washer	2
17	AN960-1216L	Flat Washer	2
18	916-278-3	Flat Head Socket Cap Screw	1
19	916-259-6	Wheel	1
20	311-12020	Set Screw, Cup Point	1
21	322-03240	Cotter Pin	1
22	321-16990	Clevis Pin	1

Parts List

When ordering replacement parts/kits, please specify model, serial number and color of your unit.

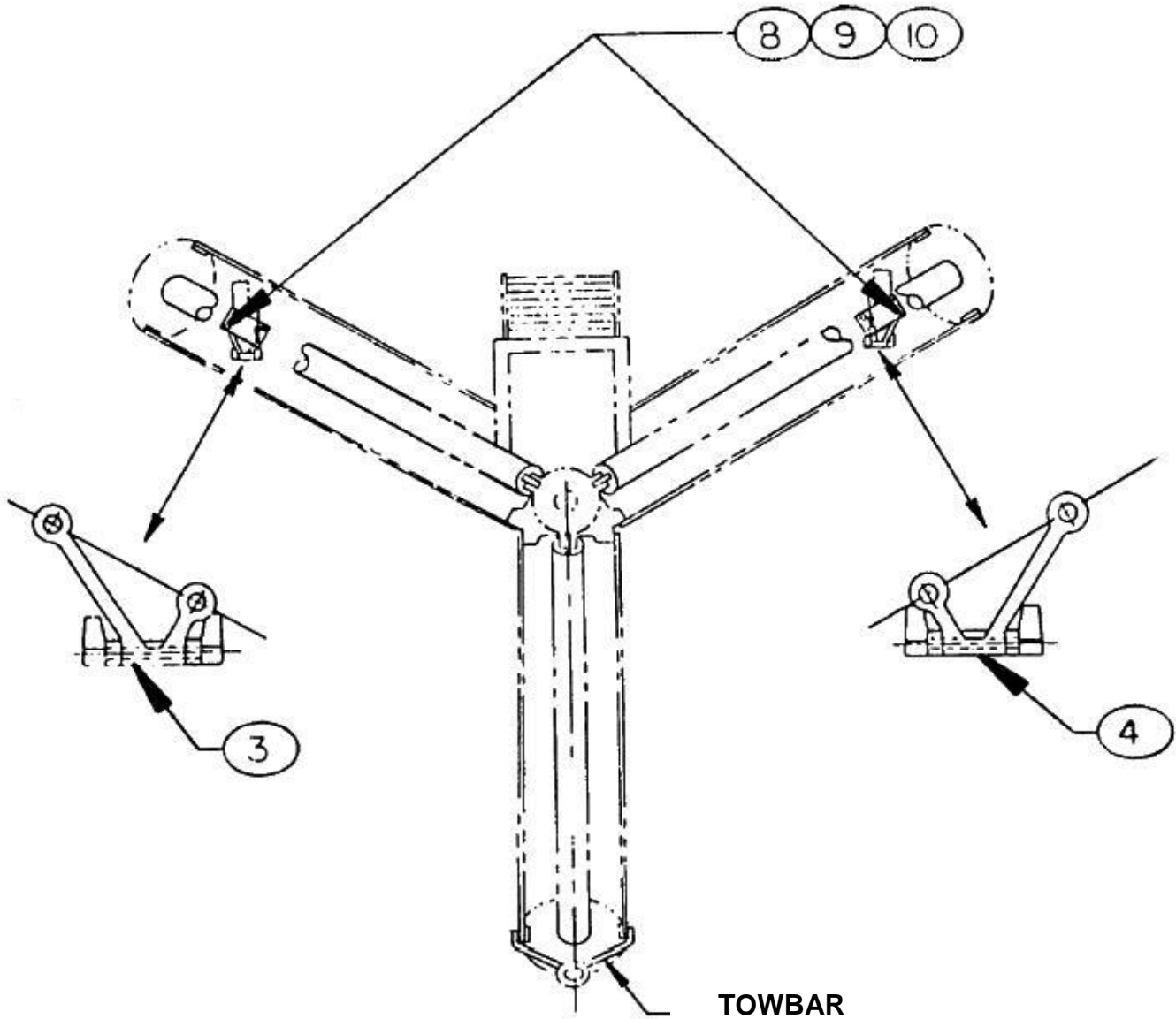

Parts List

When ordering replacement parts/kits, please specify model, serial number and color of your unit.

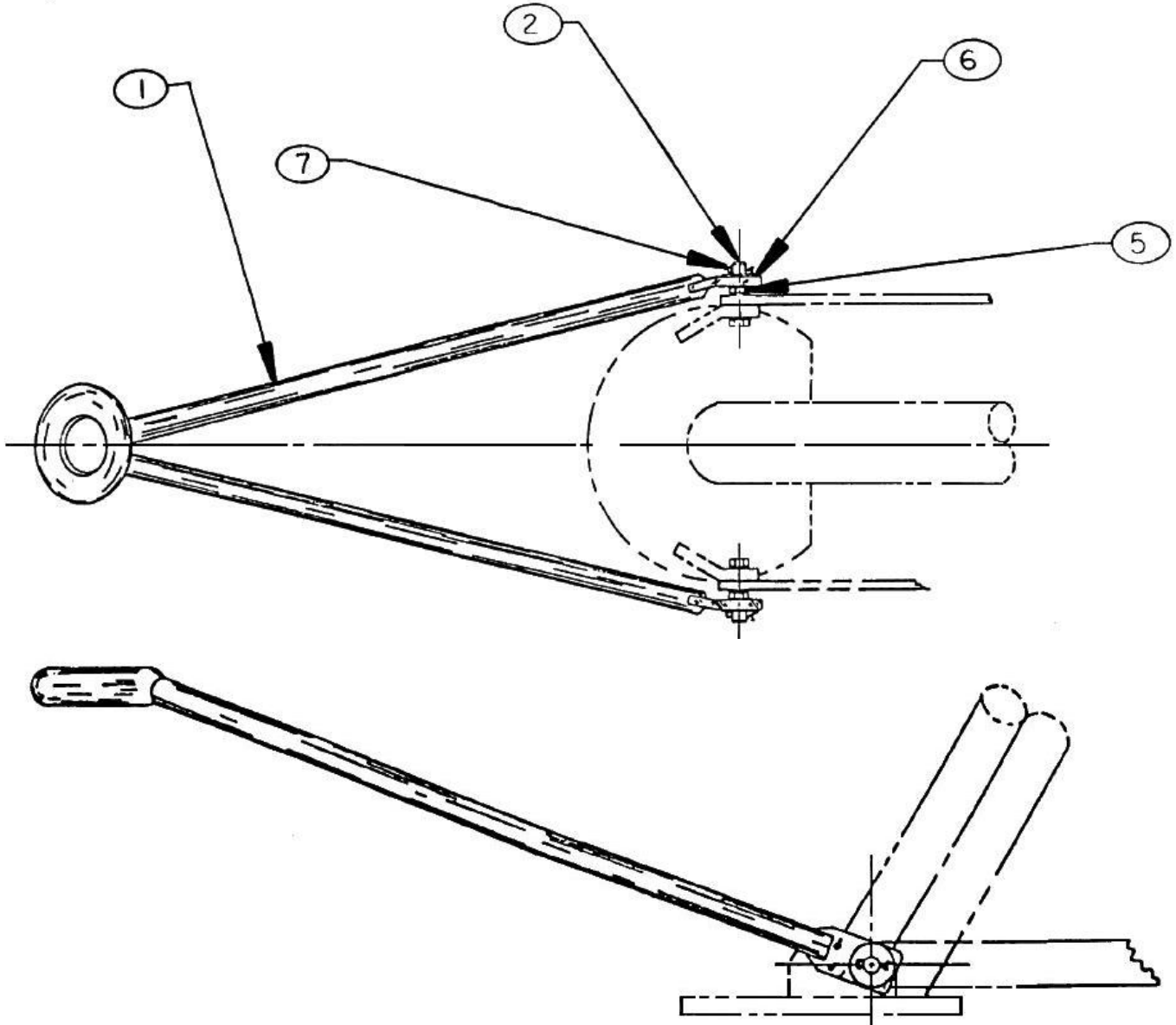

Item	Part Number	Description	Qty
	2955-D	Towbar Assembly; consists of:	
1	916-157-160	Towbar	1
2	916-160	Bolt, Towbar	2
3	916-AW	Lock Assembly, LH	1
4	916-AW-1	Lock Assembly, RH	1
5	335-53100	Hex Jam Nut	2
6	345-11036	Flat Washer	2
7	322-12400	Cotter Pin	2
8	372-20160	Hex Head Cap Screw	4
9	333-52000	Hex Nut	4
10	346-10032	Lockwasher	4

Parts List

When ordering replacement parts/kits, please specify model, serial number and color of your unit.

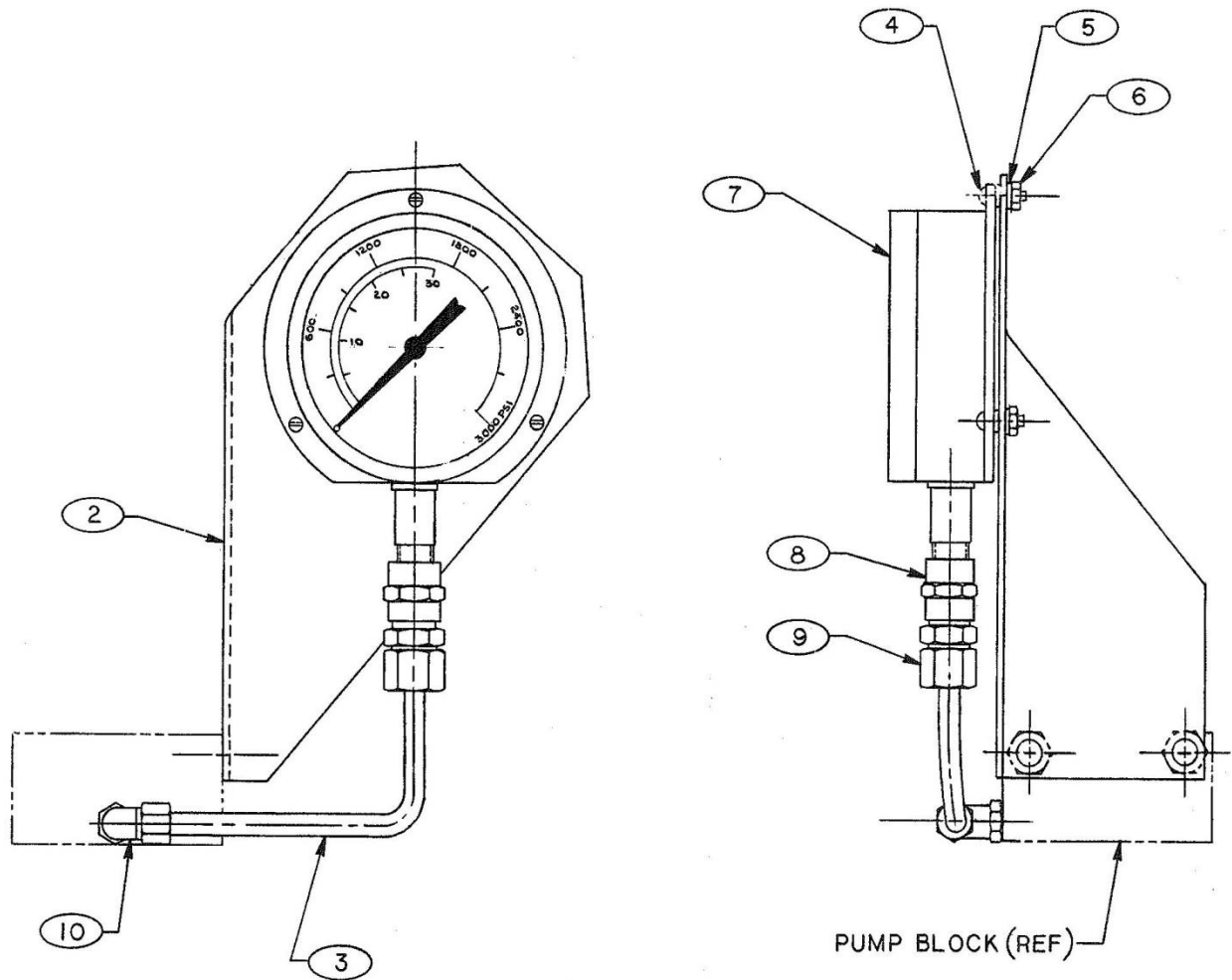

Item	Part Number	Description	Qty
	8654-G	Pressure Gauge Assembly (Optional); consists of:	
2	2955-68	Gauge Mount	1
3	SST-13849	Stainless Tube	AR
4	378-10120	Socket Head Cap Screw	3
5	346-10010	Lockwasher	3
6	333-51000	Hex Nut	3
7	8654-H	Gauge Assembly	1
8	484-20808	Pipe Coupling	1
9	457-10608-A	Male Connector	1
10	456-10606-A	Male Elbow	1



APPENDIX I

Routine Jack Maintenance Bulletins



Routine Jack Maintenance Bulletin

TO PROVIDE COMPLETE INFORMATION ON SERVICING
ColumbusJACK/REGENT QUALITY GROUND HANDLING EQUIPMENT

BULLETIN RJM 102 – PROCEDURE FOR WINTERIZATION OF HYDRAULIC AIRCRAFT JACKS

The following procedures should be utilized for optimum operational characteristics when using jacks at various temperature extremes:

1. Above 0°F (-18°C) Use MIL-PRF-5606, or equal, with no further additive required.
2. At 0° to -20°F (-18°C to 29°C) Use a mixture of 75% MIL-PRF-5606, or equal, and 25% kerosene.
3. Below -20°F (-29°C) Use a mixture of 50% MIL-PRF-5606, or equal, and 50% kerosene.

Due to most company, safety, or union regulations which restrict employees from working out-of-doors below -30°F (-34°C), there is a lack of experience beyond this point. It is permissible, however, to increase the percentage of kerosene up to 100%. As the ambient temperature increases, MIL-PRF-5606, should be added back to the system in the appropriate mixture.

The air supply should be clean and dry. At -30°F (-34°C), the air pump will start to react sluggishly and continue to operate less efficiently as the temperature decreases when a normal air supply is used. The problem can be eliminated by using a dry nitrogen source of sufficient capacity.

To ease the operation of the locknut(s) and screw extension, use "Never Freeze" by Snap-On, or equal, and apply liberally to the thread surfaces.



Routine Jack Maintenance Bulletin

TO PROVIDE COMPLETE INFORMATION ON SERVICING
ColumbusJACK/REGENT QUALITY GROUND HANDLING EQUIPMENT

BULLETIN RJM 116 –SCREW EXTENSION USAGE

When using a jack that has a screw extension, it is advisable that the screw extension be extended as far as possible, and still has the jack roll under the jacking point. If the screw extension is not properly extended, the aircraft may not be able to be raised to the desired height.

A periodic check should be made to the screw extension to ensure that the stop is operating properly to prevent over-extension. To do this, rotate the screw extension counterclockwise until it stops rotating. **DO NOT FORCE THE SCREW EXTENSION BEYOND THIS POINT.** If the screw extension does not stop rotating, remove it and repair the stop. **DO NOT USE WITHOUT THE SCREW EXTENSION STOP WORKING PROPERLY, AS THE JACK COULD FAIL WITH AN OVER-EXTENDED SCREW EXTENSION.**

BULLETIN RJM 117 – PROCEDURE FOR ADJUSTING CARTRIDGE STYLE RELIEF VALVES

It is imperative that safety relief valves on all jacks always be set between rated capacity, and rated capacity plus 10% maximum. The following procedure describes how to adjust cartridge style relief valves.

1. Position jack under jack tester.
2. Fully close release valve.
3. Remove access screw and seal. Install valve adjusting tool, Part No. 915-EB. (See illustration)

NOTE: If tool is not available, disregard this step.

4. Extend cylinder ram(s):
 - a. On single stage jacks, extend the ram approximately half way.
 - b. On multiple stage jacks, extend all rams until the smallest ram is extended approximately half way.
5. To set valves:
 - a. Using smooth, uniform pump handle strokes, manually pressurize the cylinder while monitoring either jack load gauge or load gauge on tester.
 - b. Pump handle shall "drop" or "go soft" at an indicated load between rated load and rated load plus 10% (ex: 50 ton jack should be between 50 and 55 tons).
 - c. If safety relief valve is set too high, release pressure and rotate adjusting screw counterclockwise. Repeat above steps until valve is adjusted in range.
 - d. If safety relief valve is set too low, release pressure and rotate adjusting screw clockwise. Repeat steps until valve is adjusted in range.

NOTE: If adjusting tool is not available, it is necessary to relieve pressure completely before removing valve access screw and seal. Then valve set screw can be adjusted using a 1/8 Inch Allen wrench. Valve access screw and seal must be Re-installed before jack can be re-pressurized.

6. After manual safety relief valve is adjusted, repeat above steps for air or electric pump if applicable.

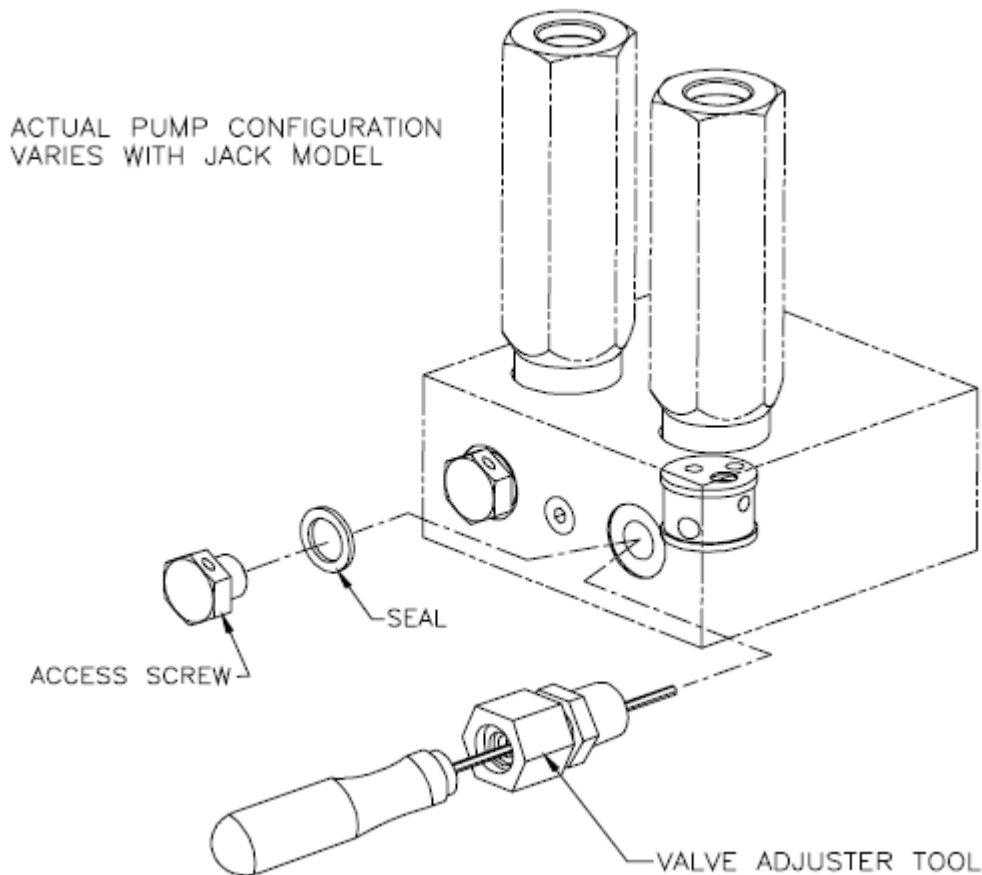

BULLETIN RJM 147 – RECOMMENDED ANNUAL JACK CERTIFICATION PROCEDURE

The following Recommended Annual Jack Certification Procedure is provided as a guide to insure that hydraulic aircraft jacks are always certified for operation. An annual time interval is a general recommendation only. The actual interval used should include factors for the climatic conditions in which the equipment is stored and the frequency of equipment use. Recommendations for Suggested Preventative Maintenance can be found in RJM 170.

1. With no external load applied to the jack, fully close release valve and fully extend ram(s) to verify function and the absence of external hydraulic leakage.



WARNING!

DO NOT APPLY PRESSURE AGAINST INTERNAL RAM STOP(S).

2. Open release valve and verify ram(s) retract fully.
3. Position jack under jack tester.

NOTE: For tripod jacks, all leg extensions should be installed on the jack.

4. Close release valve, and extend ram(s) until cup adapter contacts jack tester. Make sure that the ram of a single stage jack is partially extended and that the smaller ram of a multi-stage jack is partially extended.
5. Pressurize the jack against the jack tester. Using a calibrated pressure gauge on either the jack or the jack tester, monitor the pressure until the capacity (operating pressure) of the jack is reached.
6. With the jack pressurized against the jack tester, hold in this position for 3 minutes. Verify that the jack pressure has not decreased, indicating internal leakage.
7. Open the release valve to relieve jack pressure against the jack tester.
8. Set the safety relief valve per jack operation and maintenance manual.

BULLETIN RJM 149 – TEFLON BACKUP RING INSTALLATION PROCEDURE

When installing new Teflon backup rings on a ram or piston of any jack model, the following procedure should be observed to ensure correct installation of the ring. When installing a new backup ring, the corresponding o-ring should always be replaced also.

1. Cut existing o-ring and Teflon backup ring.
2. Clean and visually inspect the groove in the ram or piston for any nicks, scratches or score marks, which could cut the o-ring and backup ring during installation.
3. Check to ensure backup ring is clean and not damaged.
4. Set backup ring on a flat metal surface.
5. Using a propane torch, heat backup ring in a circular motion until backup ring is equally softened and pliable or flexible.
6. Carefully pick-up the HOT Teflon backup ring off the HOT metal plate and stretch the ring enough to fit over the end of the ram (piston).

NOTE: Make sure the "V" cup portion of the backup ring will face the o-ring. (see figure)

7. If backup ring does not return to size after cooling, re-heat backup ring while on the part, and cool quickly with a cold, wet towel or rag.
8. Check to ensure o-ring is clean and not damaged.
9. Carefully stretch o-ring over the end of the ram (piston). Ensure that the o-ring and the "V" cup of the backup ring are facing each other. (See figure)

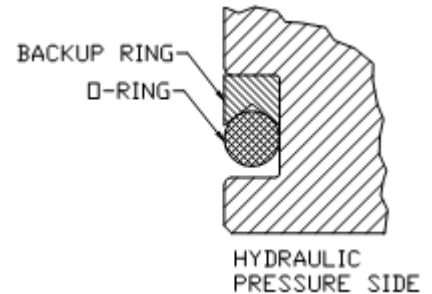



Routine Jack Maintenance Bulletin

TO PROVIDE COMPLETE INFORMATION ON SERVICING
ColumbusJACK/REGENT QUALITY GROUND HANDLING EQUIPMENT

BULLETIN RJM 170 – SUGGESTED PREVENTATIVE MAINTENANCE FOR JACKS

The following Preventative Maintenance Schedule is provided as a guide to insure that hydraulic aircraft jacks are always ready for operation. The time intervals listed are a general recommendation only. The actual interval used should include factors for the climatic conditions in which the equipment is stored and the frequency of equipment use.

Prior to Operation

1. Inspect for damaged or missing components.
2. Inspect for oil leakage and proper fluid level.
3. Inspect screw extension for mechanical stop.
4. Inspect all snap rings for engagement into grooves.
5. Inspect jack adapter for damage.

Every 6 Months

1. Inspect for worn snap ring grooves.
2. Change hydraulic filters if applicable.
3. If jack has not been used regularly, cycle jack without load.
4. Grease all lube fittings with a general purpose grease.
5. Wipe down ram(s) and screw extension with hydraulic oil.

Every 12 Months

1. Calibrate pressure gauge if applicable per RJM 173.
1. Perform "Recommended Annual Jack Certification Procedure" per RJM 147.



Routine Jack Maintenance Bulletin

TO PROVIDE COMPLETE INFORMATION ON SERVICING
ColumbusJACK/REGENT QUALITY GROUND HANDLING EQUIPMENT

BULLETIN RJM 171 – RECOMMENDED HYDRAULIC OILS

The following hydraulic oils are recommended for use in all ColumbusJACK/Regent products, though any oil compatible with Buna-N seals may be used. Proper oil level should be .5 to 1 inch below the fill port when all rams are collapsed.

Exxon/Mobil Aero HF (MIL-PRF-5606)
Exxon/Mobil DTE-11, -15
NATO Code No. H-538 (MIL-PRF-87257)
Phillips 66 X/C 5606
Royco 783 (Aderol) (MIL-PRF-6083)
Royco 782 (Aderol) (MIL-PRF-83282)
Shell Tellus 10, 15
Shell Aerofluid 31 (MIL-PRF-83282)
Shell Aerofluid 41 (MIL-PRF-5606)
Texaco Regal Oil R & O (32, 46, 100, 150, 220, 320, 460)