

Model: 8760
Two Stage Fixed Height
Hydro – Mechanical
Aviation Tripod jack

11/2018 – Rev. 01

REVISION
01

DATE
11/2018

TEXT AFFECTED
Original release

TABLE OF CONTENTS

| | <u>PAGE</u> |
|--|--------------------|
| 1.0 PRODUCT INFORMATION | 4 |
| 1.1 DESCRIPTION..... | 4 |
| 1.2 MODEL & SERIAL NUMBER..... | 4 |
| 1.3 MANUFACTURER | 4 |
| 1.4 SPECIFICATIONS | 4 |
| 2.0 SAFETY INFORMATION..... | 5 |
| 2.1 USAGE AND SAFETY INFORMATION | 5 |
| 3.0 PREPARATION PRIOR TO FIRST USE | 5 |
| 4.0 TRAINING | 6 |
| 4.1 TRAINING REQUIREMENTS | 6 |
| 4.2 TRAINING PROGRAM | 6 |
| 4.3 OPERATOR TRAINING | 6 |
| 5.0 OPERATION..... | 6 |
| 5.1 PRE OPERATION INSPECTION..... | 6 |
| 5.2 OPERATING PROCEDURES..... | 6 |
| 6.0 TROUBLE SHOOTING | 8 |
| 7.0 MAINTENANCE..... | 9 |
| 7.1 SERVICING | 9 |
| 7.2 DISASSEMBLY INSPECTION..... | 9 |
| 7.3 REPAIR AND REPLACEMENT | 9 |
| 7.4 TESTING: | 10 |
| 7.5 SPECIAL TOOLS:..... | 10 |
| 8.0 PROVISION OF SPARES..... | 11 |
| 8.1 SOURCE OF SPARE PARTS..... | 11 |
| 8.2 RECOMMENDED SPARE PARTS LISTS | 11 |
| 8.2.1 Standard..... | 11 |
| 8.2.2 Air Pump Kit..... | 11 |
| 8.2.3 Load Gauge Kit | 12 |
| 8.2.4 Adjustable Foot Kit | 12 |
| 8.2.5 Hydraulic Caster Kit | 12 |
| 8.2.6 Shock Absorber Kit | 12 |
| 8.2.7 Ladder Assembly Kit | 12 |
| 8.2.8 Remote Control Kit..... | 12 |
| 9.0 IN SERVICE SUPPORT..... | 13 |
| 10.0 GUARANTEES/LIMITATION OF LIABILITY | 13 |
| 11.0 APPENDICES | 13 |

This product can not be modified without the written approval of Tronair, Inc. Any modifications done without written approval voids all warranties and releases Tronair, Inc., its suppliers, distributors, employees, or financial institutions from any liability from consequences that may occur. Only Tronair OEM replacement parts shall be used.



CAUTION!

Aircraft manufacturer's specifications and instructions must be followed. In the event of contradiction between aircraft manufacturer's specifications and Malabar's, aircraft manufacturer's will prevail.

1.0 PRODUCT INFORMATION

1.1 DESCRIPTION

The Malabar Fixed Height Tripod Jack Model 8760 is a 30 ton capacity two stage hydraulic jack designed primarily for use in aircraft maintenance. It consists of a tripod structure, hydraulic cylinder assembly, reservoir, valve block assembly, hand pump assembly, tow handle, swivel casters and the following optional equipment:

- Air pump
- Load gauge
- Adjustable swivel foot
- Adjustable swivel foot with hydraulic caster
 - Shock absorber for hydraulic caster option
- Ladder
- Remote control (platform operated)

The jack tow handle readily connects to tow vehicle for ease of transport. The jack should never be used as a personnel carrier while being towed or in motion. On jacks equipped with spring loaded swivel casters, the jack leg pads are raised off the ground. The casters will retract and the pads rest on the ground when a load is applied to the jack. On jacks equipped with adjustable swivel foot, the jack leg pads have adjustable leveling feet for slightly uneven or sloping floors. On jacks equipped with hydraulic casters, leveling of the jack is faster and easier by selectively extending or retracting the caster plungers utilizing the caster hand pump or release valve. Extending the casters also increases the towing ground clearance. For extended towing over rough surfaces, a hydro-pneumatic shock absorber is provided to cushion against towing loads and improve caster life.

1.2 MODEL & SERIAL NUMBER

Reference nameplate on unit

1.3 MANUFACTURER

Malabar International
 1 Air Cargo Pkwy East
 Swanton, Ohio 43558 USA

Telephone: (419) 866-6301 or 800-426-6301
 E-mail: sales@malabar.com
 Website: www.malabar.com

1.4 SPECIFICATIONS

| | |
|---|----------------------------|
| Rated Capacity | 30 tons (27.2 m. tons) |
| Side Load | 15% of vertical load |
| Roll Under Height | 92.5 in (2350 mm) |
| Low Height | 91 in (2311 mm) |
| Hydraulic Lift | 104 in (2642 mm) |
| Extension Screw | 12 in (305 mm) |
| Total Extended Height | 207 in (5258 mm) |
| Oil Pressure at Rated Capacity | 2420 psig (170 kg/sq cm) |
| Safety Pop-off Valves | |
| — System Relief Valve set at | 33 ton (29.9 m. tons) |
| — Thermal Relief Valve set at | 37.5 ton (34 m. tons) |
| — Hydraulic Caster Relief Valves set at | 450 psig (31.6 kg/sq cm) |
| Proof Load | 45 ton (40.8 m. tons) |
| Reservoir Capacity | 26 gal (98.4 l) |
| Hydraulic Fluid | MIL-PRF-5606 or equivalent |
| Maximum Towing Speed | 5 mph (8 km/h) |
| Approximate Jack Net Weight | 1900 lbs (862 kg) |

2.0 SAFETY INFORMATION

2.1 USAGE AND SAFETY INFORMATION

To insure safe operations please read the following statements and understand their meaning. Also refer to your equipment manufacturer's manual for other important safety information. This manual contains safety precautions which are explained below. Please read carefully.



WARNING!

Warning is used to indicate the presence of a hazard that can cause **severe personal injury, death, and/or substantial property damage** if the Warning Notice is ignored.



CAUTION!

Caution is used to indicate the presence of a hazard, which will or can cause **minor personal injury or property damage** if the Caution Notice is ignored.

3.0 PREPARATION PRIOR TO FIRST USE

Disregard the following erection procedure if the jack is shipped fully assembled. If the jack is shipped partially assembled, erection is accomplished by following the suggested sequence below (also see figures 1A & 1B):

1. Install sling under tripod head of cylinder assembly and support from a crane or forklift capable of lifting 4000 lbs (1814 kg) to a height of 10 ft (3 m)
2. Install legs, tripod head pins and retaining rings.
3. Install braces.
4. Tighten all bolts.

If jack is equipped with adjustable swivel feet, perform the following procedure to calibrate bubble level:

1. Hang 2 plumb bobs (at 90°) from the tripod head with the plumb bob strings approximately parallel to the cylinder assembly (dial indicator magnetic bases work well as supports for the plumb bobs).
2. Stand on jack footpads and screw the footpad locknuts up to the end of the legs, continue turning footpad locknuts until weight of jack is off casters (one end of the pump handle fits into the footpad locknuts to provide extra leverage if required). Adjust footpad locknuts so both plumb bob strings are parallel to the cylinder assembly (carefully measure top and bottom from cylinder assembly to strings). Alternately, if jack is equipped with hydraulic casters, operate hydraulic caster hand pumps and/or release valves to extend or retract casters until both plumb bob strings are parallel to the cylinder assembly.
3. Remove cover from bubble level and adjust screws to center bubble. Lock adjustment screws and replace cover. Tag with date of calibration.
4. Raise footpads fully to stow position and reinsert pump handle in handle holder. Remove plumb bobs.
5. Bubble level should be checked periodically as directed by cognizant quality control department.

Before placing jack in operation, perform the following procedure:

1. Remove filler cap from the filler spout located at the side of the reservoir.
2. Fill jack reservoir to mark on dipstick with MIL-PRF-5606 hydraulic fluid or approved equivalent (reservoir capacity is approximately 26 gal (98.4 l)). Jack plunger must be fully retracted before filling reservoir. Replace filler cap.
3. Open release valve and operate hand pump a few strokes to bleed all air trapped under hand pump.
4. Close release valve and operate hand pump to raise plunger approximately 1 in (2.54 cm).
5. Open release valve to retract plunger fully to bleed all air trapped under jack plunger. Close release valve.
6. If jack is equipped with hydraulic casters, perform the following procedure:
 - a. Remove the elbow/breather located on top of the reservoir.
 - b. Open release valve and fully retract caster plunger.
 - c. Fill reservoir to the top with MIL-PRF-5606 hydraulic fluid or approved equivalent. Replace elbow/breather.
 - d. Open release valve and operate hydraulic caster hand pump a few strokes to bleed all air trapped under hand pump.
 - e. Close release valve and operate hand pump to extend caster approximately 1 in (2.54 cm).
 - f. Open release valve to retract caster fully to bleed all air trapped under plunger. Close release valve.
 - g. Repeat for other hydraulic casters
7. If jack is equipped with shock absorbers for the hydraulic casters, remove valve cap at end of unit and charge with nitrogen gas to 100 psig (7 kg/sq cm) using accumulator test gauge assembly (P/N 872845).

4.0 TRAINING

4.1 TRAINING REQUIREMENTS

The employer of the operator is responsible for providing a training program sufficient for the safe operation of the unit.

4.2 TRAINING PROGRAM

The employer provided operator training program should cover safety procedures concerning use of the unit in and around the intended aircraft at the intended aircraft servicing location.

4.3 OPERATOR TRAINING

The operator training should provide the required training for safe operation of the unit.

NOTE: Maintenance and Trouble Shooting are to be performed by a skilled and trained technician.

5.0 OPERATION

5.1 PRE OPERATION INSPECTION

Each time the jack is to be used, inspect the following:

1. Check the tripod structure for rigidity. Make sure all bolts are tightened.
2. Check hydraulic line connections for leaks. Tighten as required.
3. Check for hydraulic fluid leaks around the base, reservoir, tripod head, hand pump, air pump (if so equipped), hydraulic casters (if so equipped) and shock absorber (if so equipped).
4. Check hand pump for proper operation.
5. Check swivel casters for proper operation.
6. Check jack reservoir fluid level with plunger fully retracted.
7. Check hydraulic caster reservoir fluid levels with caster plungers fully retracted (if so equipped).
8. Check nitrogen charge in shock absorbers (if so equipped).

5.2 OPERATING PROCEDURES

CAUTION!



Prior to towing, engage the two trailing swivel caster locks. On jacks equipped with adjustable swivel foot, always fully retract the footpads before moving or towing the jack. On jacks with hydraulic casters, fully extend casters before moving or towing jack.

1. Position the jack under the jacking pad of the aircraft. For maximum maneuverability, verify all swivel caster locks are disengaged.
2. Raise the extension screw by turning counterclockwise until the ship adapter contacts the jacking pad or as far as the screw will travel, 12 in (30.48 cm) maximum.
3. Verify the jack is leveled (shim footpads if necessary). The jack plunger should be plumb during lifting. On jacks equipped with adjustable swivel foot, check level using the bubble level mounted on the jack. Adjust the footpads to contact the ground and plumb the jack. The footpads are adjusted by standing on the footpad and adjusting the footpad locknut as required to extend the footpad. One end of the pump handle fits the footpad locknut for final adjusting. On jacks equipped with hydraulic casters, operate hydraulic caster hand pumps to extend casters to plumb the jack and then adjust the footpads to contact the ground.

CAUTION!



Open hydraulic caster release valves to ensure the weight is taken through the footpads.

CAUTION!



On jacks equipped with air pump, air relief valve must be installed at all times. If air relief valve is removed, it is possible to over pressurize the pneumatic system which could cause equipment failure and possible bodily injury.

4. On jacks equipped with air pump, connect air supply (90-110 psig) to the 1/2 NPT air inlet at the air valve (a minimum of 28 scfm is required). Air relief valve must be properly installed. Do not attempt to remove air relief valve.

CAUTION



Locknut must be installed and operable on jack at all times. Always maintain less than 2 in (5 cm) between the locknut and the tripod head in all phases of load raising and lowering.

5.2 OPERATING PROCEDURES (*continued*)

5. To raise the load:

- a. The jack is equipped with an adjustable hand pump. The hand pump handle length can be varied by inserting the quick release pin through the clamp and appropriate hole along the handle (see figure 4). A longer handle length provides greater pumping leverage for high pressure pump operation. A shorter handle will increase the plunger stroke and allow more oil pumped per stroke. This permits a more rapid raising of the jack plunger under a light or no load.
- b. Close release valve located on the panel.
- c. Operate the air valve or hand pump until the ship adapter contacts the jacking pad. Insure the ship adapter and the jacking pad are correctly mated. The load may now be raised by operating the air valve or hand pump.
- d. Do not lift a load greater than the rated capacity of 30 tons.
- e. Do not attempt to raise the plungers beyond the rated hydraulic lift (104 inches maximum).
- f. Avoid lifting with excessive side load on the jack.
- g. Spin the locknuts down to the tripod head and plunger, as plungers are extending.

NOTE: Locknuts must engage all the way down and then back off 1/8 to 1/4 turn.

- h. Keep the release valve closed at all times.

1. To lower the load:

- a. Operate the air valve or hand pump to relieve pressure on the locknuts.
- b. Spin the locknut out of the way. If a locknut is held tight and unable to turn, insert 1/2 inch diameter pin into hole of locknut and loosen by impact.
- c. Slowly open the release valve located on the panel to lower the load. The speed of lowering is controlled by the amount the release valve is opened.
- d. Close release valve after the plungers are fully retracted.
- e. Lower the extension screw by turning clockwise.
- f. Fully retract the adjustable footpads (if so equipped).
- g. Fully extend hydraulic casters (if so equipped).
- h. Cover the jack when not in use to prevent entrance of contaminants and water into the cylinder.

6.0 TROUBLE SHOOTING

| TROUBLE | PROBABLE CAUSE | REMEDY |
|--|--|---|
| Jack will not raise | Release valve open (Oil passing back into reservoir) | Close valve firmly |
| | Intake valve open. (Oil passing back into reservoir) | Pump rapidly to flush dirt off |
| | Discharge valve open (Oil passing back into pump chamber) | Pump rapidly to flush dirt off |
| | Sticking intake valve | Remove pump from jack base. Unscrew valve block. Clean or replace valve |
| | Clogged screen | Remove and clean |
| | Lack of oil. Air under plunger | Refill. Check for leaks. Bleed air out by opening release valve. Pump rapidly a few times and close release valve |
| Jack will not raise to full height | Lack of oil | Refill, check for leaks |
| | Sticking intake valve | Remove pump from jack base. Unscrew valve block. Clean or replace ball valves. Re-tighten or repair |
| Jack will not raise capacity load | High pressure leaks (At pump or release valve) | Reseat valve |
| | Leaky release valve | Reseat valve and clean valve block |
| Jack raises and falls during each stroke | Leaky discharge valve | Tighten or replace ball valve or packing |
| Jack will not hold up load | Leaky release valve | Reseat valve |
| | Defective "O" ring and back up ring | Remove plunger and replace "O" ring and back up ring |
| Jack will not lower the load | Damaged release valve | Remove and replace parts as needed |
| | Bent plunger | Replace |
| Jack will not close completely | Air under plunger | Bleed air out. Open release valve and pump rapidly several times. Close valve |
| Handle stroke only partly effective | Air in pump chamber | Open release valve and pump rapidly several times. Close valve |
| | Sticking intake valve | Remove pump and clean valve block |
| | Clogged screen | Remove and clean |
| Handle raises without effort | Leaky intake valve | Remove pump and clean valve block |
| Handle snaps back | Sticking intake valve | Open release valve. Pump rapidly several times. Close valve |
| | Clogged screen | Remove and clean |

7.0 MAINTENANCE

7.1 SERVICING

Servicing the jack consists primarily of the following:

1. When in use the jack and hydraulic caster (if so equipped) reservoirs should be kept at the proper level with hydraulic fluid MIL-PRF-5606 or approved equivalent. Always check fluid levels with jack and hydraulic caster plungers fully retracted.
2. When in use, the nitrogen precharge in the hydraulic caster shock absorbers (if so equipped) should be maintained at 100 psig (7.0 kg/sq cm).
3. Grease the swivel casters.
4. Lubricate hand pump pivot pins.
5. Fill pump lubricator with SAE #10 oil.
6. If the jack has been put into storage or has not been used, the plungers must be fully extended and retracted every 90 days to exercise the seals. A portion of the lift should be operated by the air pump (if so equipped) and a portion by the hand pump. Also, the hydraulic caster plungers must be fully extended and retracted by operating the hydraulic caster hand pumps and release valves.

7.2 DISASSEMBLY INSPECTION

CAUTION!



The jack thermal relief valve and system relief valve, located in the jack valve block assembly, should not be removed unless absolutely necessary. The jack thermal relief valve is set to by-pass hydraulic fluid back to the reservoir at 20-25% above the rated capacity of 30 tons. The jack system relief valve is set to by-pass hydraulic fluid back to the reservoir at 5- 10% above the rated capacity of 30 tons. If adjustment is required, see procedure under 7.4 Testing.

CAUTION!



The hydraulic caster relief valves (if so equipped), located in the hydraulic caster valve block assemblies, should not be removed unless absolutely necessary. The hydraulic caster relief valves are set to by-pass hydraulic fluid back to the reservoirs at 450 ± 10 psig (31.6 ± 0.7 kg/sq cm) if adjustment is required, see procedure under 7.4 Testing.

When necessary to disassemble the jack and/or the hydraulic casters (if so equipped), open all release valves, drain all hydraulic fluid from reservoirs and carefully inspect the following:

1. Inspect interior walls of cylinders for smoothness and freedom from rust, nicks, scratches and excessive wear.
2. Check plungers, extension screw, cylinders, tripod head, etc., for corrosion, wear and condition of threads.
3. Verify that the extension screw has a positive stop to prevent it from being extended beyond its safe thread engagement.
4. Inspect packings, seals, gaskets and wipers in the cylinder assembly, hand pumps and hydraulic caster assemblies for cuts, scratches, deterioration and distortion.
5. Inspect upper and lower bearings for excessive scoring and/or wear.
6. Check oil screen located in the valve block for cleanliness.
7. Inspect valves and valve seats in the hand pump bodies and valve blocks for scratches, dents and proper seating of the balls.
8. Inspect all pivot pins for wear, cracks, pits or evidence of damage or pending damage.
9. Check tripod structure for damages.
10. Inspect all areas for excessive dirt, oil, dust and chips.

7.3 REPAIR AND REPLACEMENT

No definite time schedule can be established for the overhaul of the jack for replacement of the various moving parts. The number of times the jack is raised and lowered and the amount of load raised at each operation materially affect the life of the working parts. Do not overload the jack. Overloading is dangerous, will hasten the need for overhaul and may damage the jack. During overhaul, replace all parts that do not pass disassembly inspection requirements. Regardless of apparent condition, replace all parts marked with (◆) and (♣) in the parts breakdown. A repair parts kit (P/N 8760PK) which contains all of the parts marked with (◆) and a hydraulic caster repair parts kit (P/N 8818PK) which contains all of the parts marked with (♣) are available and recommended to keep on hand at your facility. Coat all O-rings and back-up rings with hydraulic fluid MIL-PRF-5606 prior to assembly. Clean all metal parts with clean solvent and dry with compressed air. Lubricate all threads. Use teflon tape carefully on all pipe threads. Remove excess tape because it can clog valves and passages. If ball valves, located in valve blocks, do not seat properly, they may need to be resealed by tapping the ball into the valve seat with a brass rod cupped at one end.

7.0 Maintenance continued on following page.

7.0 MAINTENANCE (continued)

7.4 TESTING:

Place jack in a load indicating test fixture. Make sure the test adapter is 3/4 inch male spherical radius. Operate hand pump to extend plungers against the test adapter. Make sure ship adapter and test adapter are correctly mated. Verify that the outer plunger is fully extended and the inner plunger is partially extended. Load test the jack at rated capacity of 30 tons. If the jack fails to operate properly, check for trouble as indicated in the Trouble Shooting Chart. With the plungers extended and supporting the capacity load, allow the jack to stand for 10 minutes. Any excess settling indicates leakage in the hand pump, check valves or jack packing seals. Check for hydraulic fluid leaks and replace all defective parts.

If adjustment is required for the jack thermal relief valve, perform the following procedure:

1. Remove plug (figure 3, item 8) to expose thermal relief valve. Close release valve (figure 3, item 2).
2. Place jack in a load indicating test fixture. Make sure the test adapter is 3/4 inch male spherical radius. Operate hand pump to extend plungers against the test adapter. Make sure ship adapter and test adapter are correctly mated. Verify that the outer plunger is fully extended and the inner plunger is partially extended.
3. While operating the hand pump, adjust set screw (figure 3, item 9) until the thermal relief valve by- passes hydraulic fluid back to the reservoir at 36 to 37.5 tons.
4. Replace plug (figure 3, item 8). Once more operate hand pump to verify correct setting.
5. Open release valve to relieve pressure.

If adjustment is required for the jack system relief valve, perform the following procedure:

1. Remove plug (figure 3, item 8) to expose system relief valve. Close release valve (figure 3, item 2).
2. Place jack in a load indicating test fixture. Make sure the test adapter is 3/4 inch male spherical radius. Operate hand pump to extend plungers against the test adapter. Verify that the outer plunger is fully extended and the inner plunger is partially extended.
3. While operating the hand pump, adjust set screw (figure 3, item 9) until the system relief valve by- passes hydraulic fluid back to the reservoir at 31.5 to 33 tons.
4. Replace plug (figure 3, item 8). Once more operate hand pump to verify correct setting.
5. Open release valve to relieve pressure.

If adjustment is required for the hydraulic caster relief valves (if so equipped), perform the following procedure:

1. Remove plug (figure 10, item 12) to expose relief valve. Close release valve (figure 10, item 6).
2. Remove plug (figure 10, item 33) and install a 0-1000 psig test gauge.
3. Operate the hydraulic caster hand pump (figure 10, item 17) to fully extend caster. Continue to operate hand pump until the relief valve by-passes hydraulic fluid back to the reservoir at 450 ± 10 psig (31.6 ± 0.7 kg/sq cm).
4. Replace plug (figure 10, item 12). Once more operate hand pump to verify correct setting.
5. Open release valve to relieve pressure, remove test gauge and replace plug (figure 10, item 33).
6. Repeat for other hydraulic casters.

7.5 SPECIAL TOOLS:

The following special tools are necessary to disassemble/reassemble the cylinder assembly, the hydraulic casters (if so equipped) and the shock absorber assembly (if so equipped). These tools may be purchased upon request:

| Part Number | Description | Qty |
|-------------|---|-----|
| 876095 | Spanner wrench, inner stop ring | 1 |
| 876096 | Spanner wrench, outer stop ring | 1 |
| 490-028 | Spanner wrench, hydraulic caster cap | 1 |
| 876094 | Lifting tool, inner plunger | 1 |
| 876093 | Lifting tool, outer plunger | 1 |
| 876070 | Lifting tool, tripod head | 1 |
| 876097 | Lifting tool, cylinder | 1 |
| 872845 | Accumulator test gauge assembly, 0-300 psig | 1 |

8.0 PROVISION OF SPARES

8.1 SOURCE OF SPARE PARTS

Spare parts may be obtained from the manufacturer:

Malabar International

1 Air Cargo Pkwy East
Swanton, Ohio 43558 USA

Telephone: (419) 866-6301 or 800-426-6301

E-mail: sales@malabar.com

Website: www.malabar.com

8.2 RECOMMENDED SPARE PARTS LISTS

The following spare parts are recommended and available upon request. Reference the following page(s) for Replacement Parts and Kits available.

8.2.1 Standard

| Part Number | Description | Qty |
|-------------|--|-----|
| 8760PK | Repair parts kit | |
| 56010-1 | Valve block assembly | 1 |
| 79366 | Release valve knob | 1 |
| 79365 | Release valve stem | 1 |
| 65228 | Release valve lock screw | 1 |
| 55155 | Safety pop-off valve assembly | 2 |
| 79571-1 | Hand pump assembly | 1 |
| 55762-7 | Pump handle | 1 |
| 76347 | Reservoir gasket | 1 |
| 79562 | Filler cap with dipstick | 1 |
| 424-005 | Drain cock valve | 1 |
| 79596 | Placard, instruction | 1 |
| 55991-17 | Placard, tonnage, 120 ton | 1 |
| 55998 | Sticker, Malabar | 2 |
| 55994 | Sticker, fluid | 1 |
| 75940 | Sticker, towing | 1 |
| 73334A | Spring loaded swivel caster with swivel lock | 3 |
| 876009 | Inner Lower bearing | 1 |
| 876012 | Outer Lower bearing | 1 |
| 876019 | Inner Stop Ring | 1 |
| 876020 | Outer Stop Ring | 1 |
| 51580 | Ship adapter | 1 |
| 79595 | Rain hat | 1 |

8.2.2 Air Pump Kit

| Part Number | Description | Qty |
|-------------|--------------------|-----|
| 441-002 | Air pump | 1 |
| 441-038 | Seal kit, air pump | 1 |
| 421-004 | Air valve | 1 |
| 425-001 | Air relief valve | 1 |
| 471-001 | Lubricator | 1 |
| 499-002 | Muffler | 1 |
| 481-001 | Oil screen | 1 |

8.2 Recommend spare parts lists continued on following page.

8.2 RECOMMENDED SPARE PARTS LISTS *(continued)*

8.2.3 Load Gauge Kit

| Part Number | Description | Qty |
|-------------|-----------------|-----|
| 876015 | Load gauge | 1 |
| 424-001 | Shut- off valve | 1 |

8.2.4 Adjustable Foot Kit

| Part Number | Description | Qty |
|-------------|------------------|-----|
| 75941 | Sticker, footpad | 1 |
| 79225 | Level Assembly | 1 |

8.2.5 Hydraulic Caster Kit

| Part Number | Description | Qty |
|-------------|-----------------------------------|-----|
| 8818PK | Hydraulic caster repair parts kit | 3 |
| 881802-1 | Swivel caster | 1 |
| 881802-2 | Swivel caster with swivel lock | 2 |
| 483-006 | Breather | 3 |
| 79366 | Release valve knob | 3 |
| 79365 | Release valve stem | 3 |
| 65228 | Release valve lockscrew | 3 |
| 881816 | Safety pop-off valve assembly | 3 |

8.2.6 Shock Absorber Kit

| Part Number | Description | Qty |
|-------------|----------------|-----|
| 490-029 | Shock absorber | 3 |
| MS28778-6 | O-ring | 6 |

8.2.7 Ladder Assembly Kit

| Part Number | Description | Qty |
|-------------|-----------------------|-----|
| 76378 | Safety chain assembly | 1 |

8.2.8 Remote Control Kit

| Part Number | Description | Qty |
|-------------|------------------|-----|
| 421-004 | Air valve | 1 |
| 85416 | Release valve | 1 |
| 76158 | Placard, caution | 2 |

9.0 IN SERVICE SUPPORT

Contact Malabar, Inc. for technical services and information. See Section 1.3 – Manufacturer.

10.0 GUARANTEES/LIMITATION OF LIABILITY

- I. Seller warrants each new product of its manufacture to be free from defects in material or workmanship, under proper, reasonable, and normal use and service.
- II. The warranty period shall be as follows:
 - A. For Malabar equipment, with the exception of Tripod Jacks, the warranty period is one (1) year after date of shipment.
 - B. For Malabar Tripod Jacks, the warranty period is three (3) years after date of shipment.
- III. Where Buyer claims an alleged defect in material or workmanship and so advises Seller in writing within ten (10) days after discovery thereof, then and in such event, Buyer shall return said equipment, transportation prepaid, to the Seller, provided such return is timely and within the above-mentioned warranty period. This warranty and liability of the Seller is expressly limited solely to replacement or repair of defective parts or goods, and return at Buyer's expense to Buyer after finding by Seller the product was defective prior to original shipment or, at the option of Seller, to providing refund to Buyer of the purchase price for said product.
- IV. It is further expressly understood and agreed that:
 - A. THERE IS NO WARRANTY, REPRESENTATION OF CONDITION OF ANY KIND, EXPRESS OR IMPLIED, (INCLUDING NO WARRANTY OF MERCHANTABILITY OR OF FITNESS) EXCEPT THAT THE MATERIAL SHALL BE OF THE QUALITY SPECIFIED IN APPLICABLE SPECIFICATIONS, AND NONE SHALL BE IMPLIED BY LAW. Except as otherwise provided herein, quality shall be in accordance with Seller's specifications. Final determination of the material for the use contemplated by Buyer is the sole responsibility of Buyer and Seller shall have no responsibility in connection with such suitability, and
 - B. Buyer's sole and exclusive remedy shall be repair or replacement of defective parts or goods by the Seller. Should the goods, in the judgment of Seller, preclude the remedying of the warranted defects by repair or replacement, the Buyer's sole and exclusive remedy shall be the refund of the purchase price, and
 - C. Seller shall not be liable for prospective profits or special, indirect or consequential damages, nor shall any recovery of any kind against Seller be greater in amount than the purchase price of the specific material sold and causing the alleged loss, damage or injury. Buyer assumes all risk and liability for loss, damage or injury to persons or property of Buyer or others arising out of use or possession of any product or part sold hereunder, and
 - D. Seller shall in no way be deemed or held to be obligated, liable or accountable upon or for any guarantees or warranties, express or implied, or created by statute or by operation of law or otherwise, in any manner of form beyond its express agreement above set forth, and
 - E. No warranty herein shall apply to any product which shall have been repaired or altered, unless such alteration or repair has been made by Seller or if, after return to and inspection by Seller, the product is found by Seller to have been subject to misuse, negligence or accident, and
 - F. No warranty of any nature is made by Seller as to any component forming a part of the product sold and Buyer shall receive only such warranties offered by such other manufacturer of such component, and
 - G. Seller does not assume nor does Seller authorize any other person to assume for it any other liability or make any warranty in connection with the sale of its products.

11.0 APPENDICES

APPENDIX I Safety Data Sheet – MIL-PRF-5606 Hydraulic Fluid

PNEUMATIC / HYDRAULIC DIAGRAM

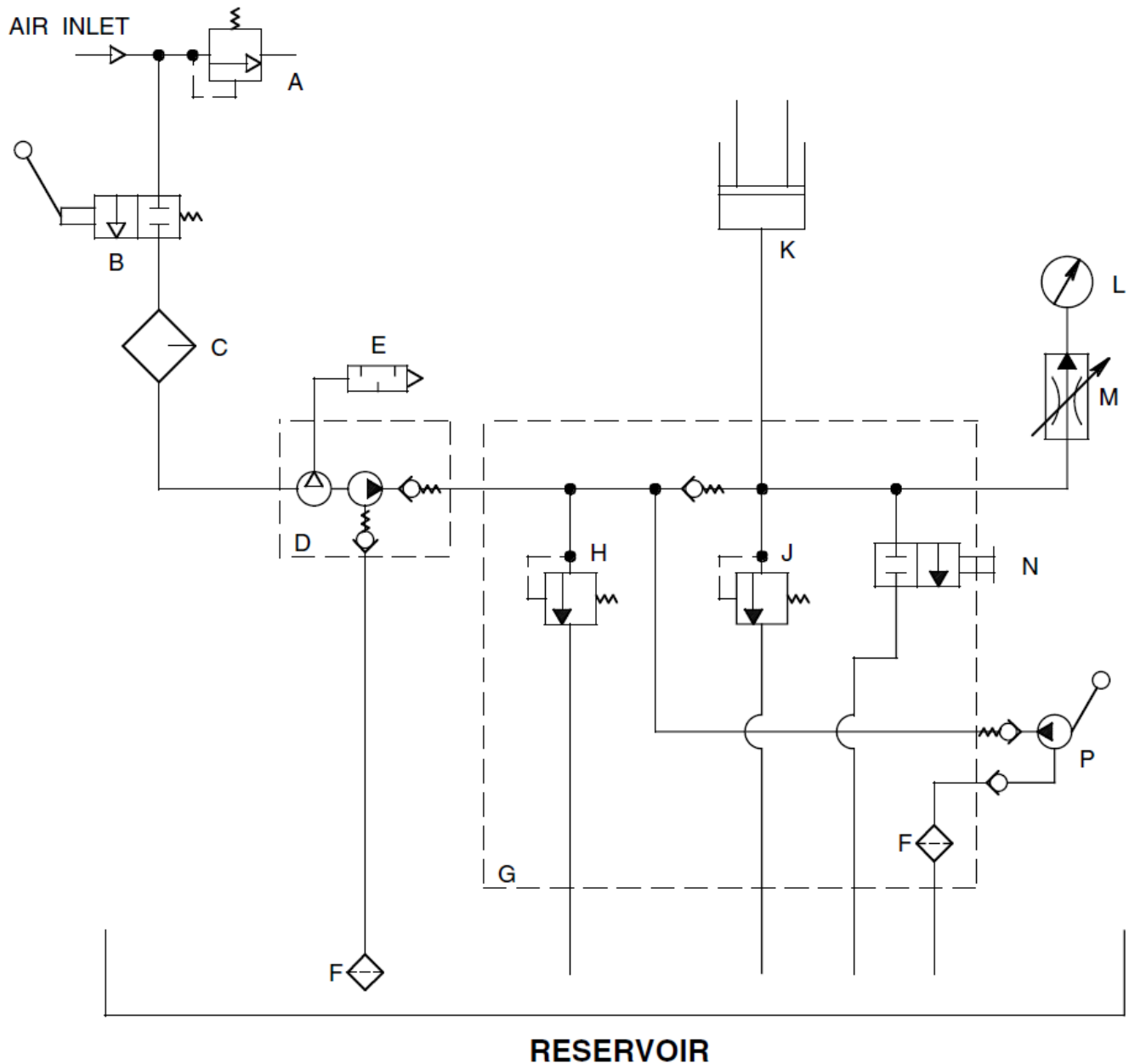

- A - AIR RELIEF VALVE
- B - AIR VALVE
- C - LUBRICATOR
- D - AIR PUMP
- E - MUFLER
- F - OIL SCREEN
- G - VALVE BLOCK

- H - SYSTEM RELIEF VALVE
- J - THERMAL RELIEF VALVE
- K - CYLINDER ASSEMBLY
- L - LOAD GAUGE
- M - SHUT-OFF VALVE
- N - RELEASE VALVE
- P - HAND PUMP

PNEUMATIC / HYDRAULIC DIAGRAM WITH REMOTE CONTROL

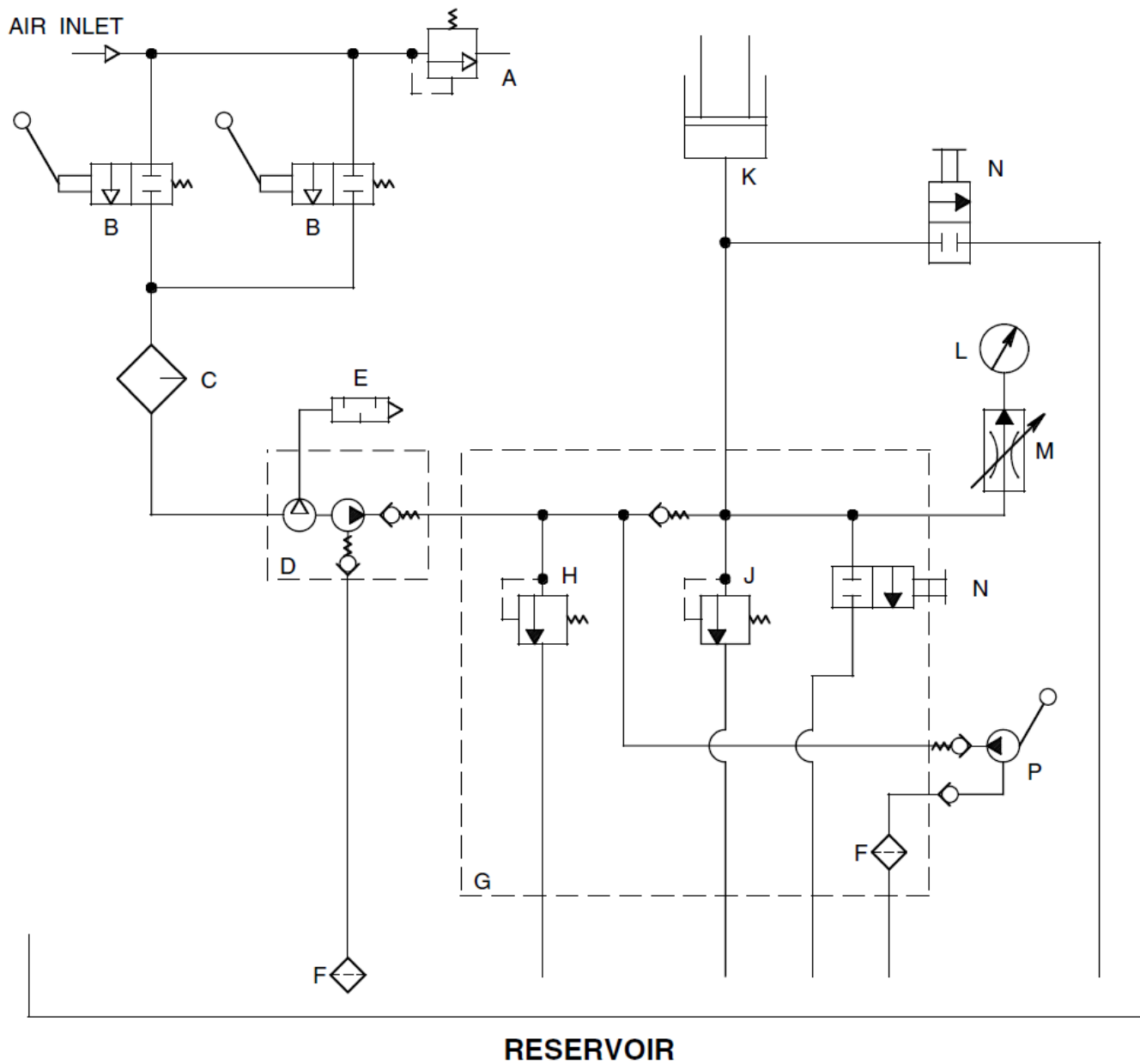

- A - AIR RELIEF VALVE
- B - AIR VALVE
- C - LUBRICATOR
- D - AIR PUMP
- E - MUFFLER
- F - OIL SCREEN
- G - VALVE BLOCK

- H - SYSTEM RELIEF VALVE
- J - THERMAL RELIEF VALVE
- K - CYLINDER ASSEMBLY
- L - LOAD GAUGE
- M - SHUT-OFF VALVE
- N - RELEASE VALVE
- P - HAND PUMP

HYDRAULIC CASTER DIAGRAM

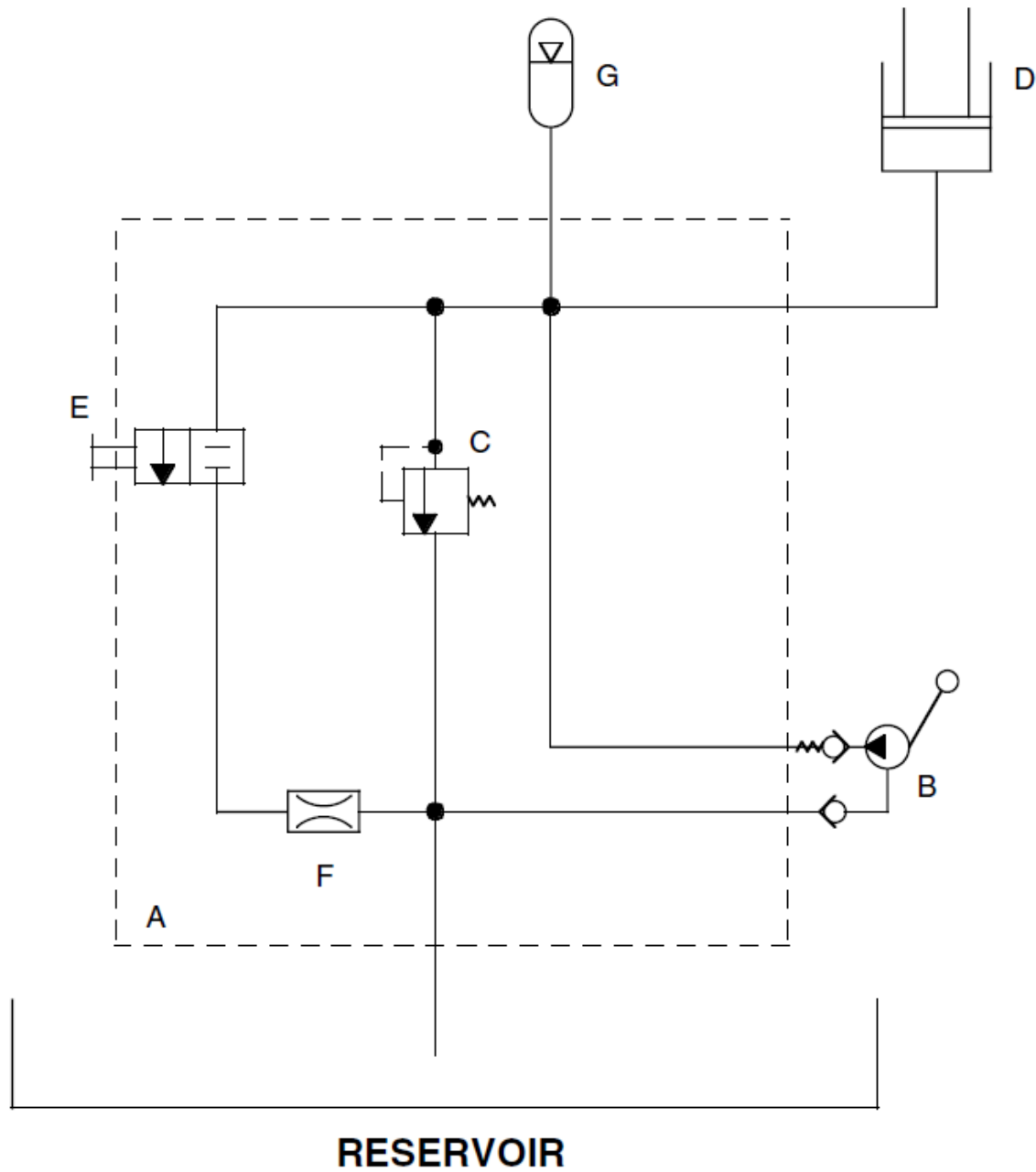

- A - VALVE BLOCK
- B - HAND PUMP
- C - RELIEF VALVE
- D - CYLINDER ASSEMBLY

- E - RELEASE VALVE
- F - METERING ORIFICE
- G - SHOCK ABSORBER

This page left blank intentionally

Parts List – Figure 1A

When ordering replacement parts/kits, please specify model, serial number and color of your unit.

◆ PART OF REPAIR PARTS KIT

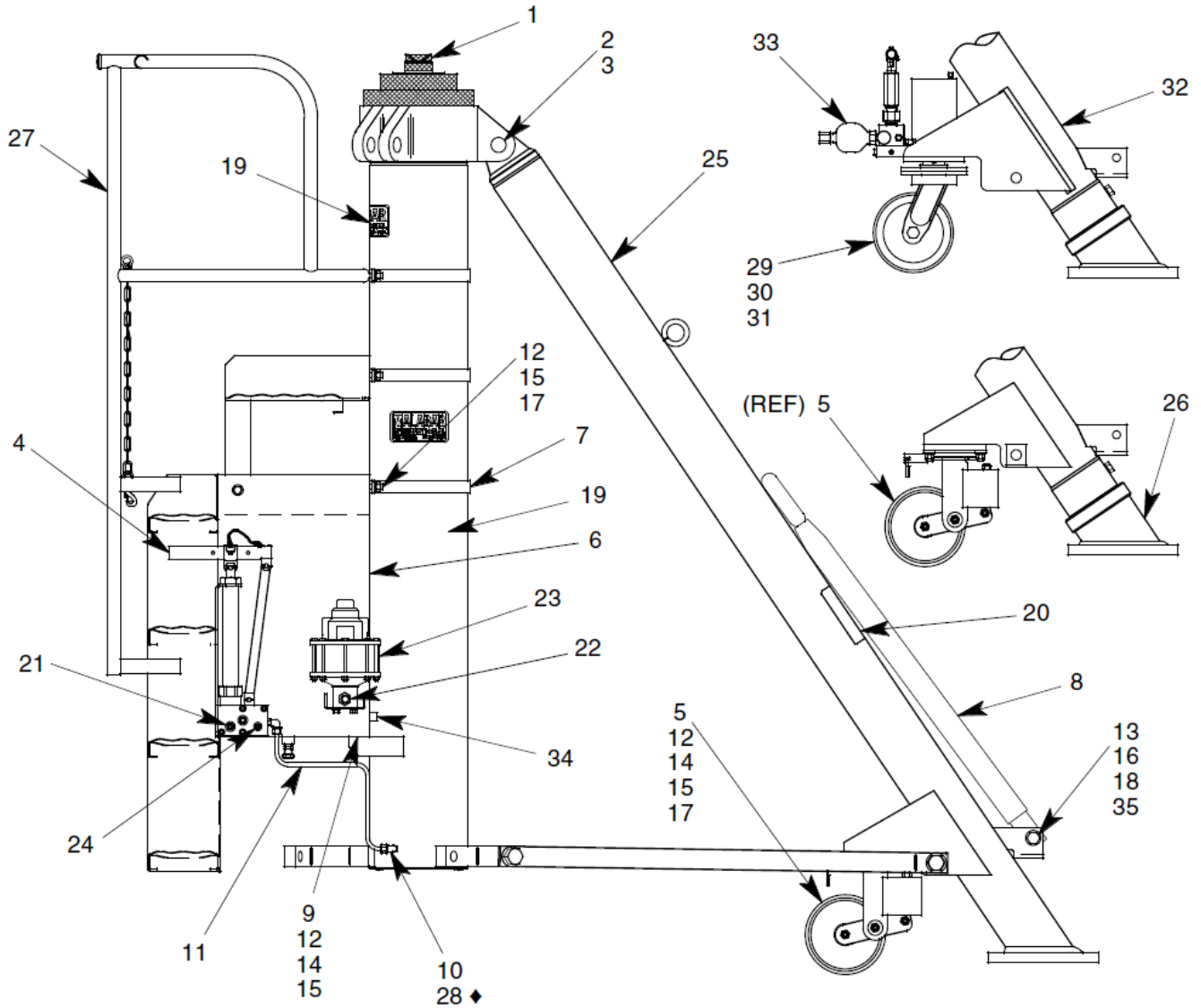

Parts List – Figure 1A

When ordering replacement parts/kits, please specify model, serial number and color of your unit.

| Item | Part Number | Description | Qty |
|------|----------------|--|-----|
| 1 | 876099 | CYLINDER ASSEMBLY | 1 |
| 2 | 76319 | TRIPOD HEAD PIN | 3 |
| 3 | 55923-150 | RETAINING RING | 1 |
| 4 | 56010-1 | VALVE BLOCK ASSEMBLY | 1 |
| 5 | 876035 | SPRING LOADED SWIVEL CASTER | 1 |
| 6 | 876030 | RESERVOIR | 1 |
| 7 | 876031 | STRAP | 1 |
| 8 | 79535 | TOW HANDLE | 1 |
| 9 | 78985 | SPACER | 1 |
| 10 | 722-018 | ELBOW, 3/8 TUBE x 3/8 SAE O-RING | 1 |
| 11 | 732-010 | TUBE, 3/8 OD X .065 WALL | AR |
| 12 | 321-006 | HHCS, 1/2-13 x 1-3/4 LG | 16 |
| 13 | 321-306 | HHCS, 3/4-10 x 4-1/2 LG | 1 |
| 14 | 362-005 | FLAT WASHER, 1/2 SAE | 28 |
| 15 | 363-004 | SPLIT LOCKWASHER, 1/2 | 16 |
| 16 | 363-006 | SPLIT LOCKWASHER, 3/4 | 1 |
| 17 | 351-003 | HEX NUT, 1/2-13 | 14 |
| 18 | 351-004 | HEX NUT, 3/4-10 | 1 |
| 19 | 55998 | STICKER, MALABAR | 2 |
| 20 | 75940 | STICKER, TOWING | 1 |
| 21 | 717-003 | PLUG, 3/8 SAE O-RING (USED w/ NO AIR PUMP KIT) | 1 |
| 22 | 717-008 | HOLLOW HEX PLUG, 1/2 MPT (USED w/ NO AIR PUMP KIT) | 1 |
| 23 | 73176 | AIR PUMP KIT | 1 |
| 24 | 717-001 | PLUG, 1/4 SAE O-RING (USED w/ NO LOAD GAUGE KIT) | 1 |
| 25 | 876044 | NON ADJUSTABLE FOOT KIT | 1 |
| 26 | 876045 | ADJ. FOOT KIT | 1 |
| 27 | 876060 | LADDER ASSEMBLY KIT | 1 |
| 28 | MS28778-6 | O-RING (PART OF ITEM 10) | 1 |
| 29 | 325-001 | FSHCS, 1/2-13 x 1-1/2 LG | 12 |
| 30 | 881801-1 | SWIVEL CASTER | 1 |
| 31 | 881801876068-2 | SWIVEL CASTER WITH SWIVEL LOCK | 2 |
| 32 | 881123 | ADJ. FOOT KIT WITH HYDRAULIC CASTER | 1 |
| 33 | 881818 | SHOCK ABSORBER KIT | 1 |
| 34 | 717-011 | PLUG, USED w/ NO R/C KIT | 1 |
| 35 | 362-007 | FLAT WASHER, 3/4 SAE | 2 |

Parts List – Figure 1B

When ordering replacement parts/kits, please specify model, serial number and color of your unit.

| Item | Part Number | Description | Qty |
|------|-------------|----------------------------------|-----|
| 1 | 876024 | BRACE | 6 |
| 2 | 76347 | RESERVOIR GASKET | 1 |
| 3 | 76346 | RESERVOIR COVER | 1 |
| 4 | 79562 | FILLER CAP WITH DIPSTICK | 1 |
| 5 | 424-005 | DRAIN COCK VALVE | 1 |
| 6 | 321-008 | HHCS, 3/8-16 x 1-1/4 LG | 6 |
| 7 | 321-101 | HHCS, GR 5, 1"-8 X 4" LG | 12 |
| 8 | 362-003 | FLAT WASHER, 3/8 SAE | 6 |
| 9 | 363-008 | SPLIT LOCKWASHER, 1" | 12 |
| 10 | 351-005 | HEX NUT, 1"-8 | 12 |
| 11 | 397-005 | SELF TAPPING SCREW, #4 x 3/16 LG | 10 |
| 12 | 55991-7 | PLACARD, 30 TONS | 1 |
| 13 | 79596 | PLACARD, INSTRUCTION | 1 |
| 14 | 55994 | STICKER, FLUID | 1 |
| 15 | 79595 | RAIN HAT (NOT SHOWN) | 1 |
| 16 | 876014 | LOAD GAUGE KIT | 1 |
| 17 | 876038 | LEG W/HANDLE HOLDER | 1 |
| 18 | 876039 | LEG W/TOW HANDLE | 1 |
| 19 | 876040 | LEG | 1 |
| 20 | 363-003 | SPLIT LOCKWASHER, 3/8 | 6 |
| 21 | 79225 | LEVEL ASSEMBLY | 1 |
| 22 | 876090 | REMOTE CONTROL KIT | 1 |
| 23 | 362-013 | FLAT WASHER, 1" SAE | 24 |

Parts List – Figure 2

When ordering replacement parts/kits, please specify model, serial number and color of your unit.

◆ PART OF REPAIR PARTS KIT

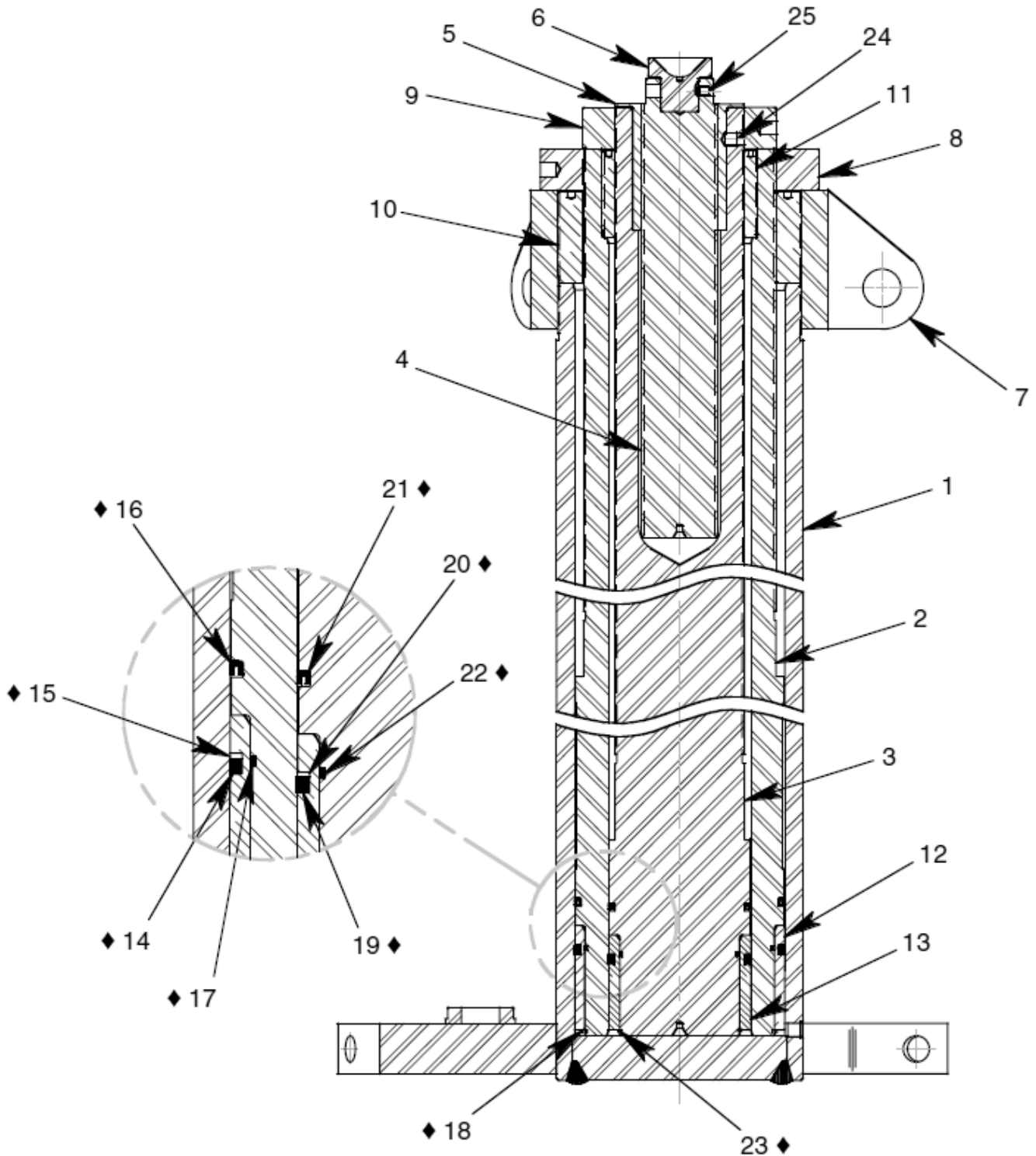

Parts List – Figure 2

When ordering replacement parts/kits, please specify model, serial number and color of your unit.

| Item | Part Number | Description | Qty |
|------|---------------|--|-----|
| | 876099 | Cylinder Assembly; consists of: | |
| 1 | 876005 | CYLINDER | 1 |
| 2 | 876011 | OUTER PLUNGER | 1 |
| 3 | 876010 | INNER PLUNGER | 1 |
| 4 | 876008 | EXTENSION SCREW | 1 |
| 5 | 876016 | EXTENSION SCREW NUT | 1 |
| 6 | 51580 | SHIP ADAPTER | 1 |
| 7 | 876013 | TRIPOD HEAD | 1 |
| 8 | 876018 | OUTER LOCKNUT | 1 |
| 9 | 876017 | INNER LOCKNUT | 1 |
| 10 | 876020 | OUTER STOP RING | 1 |
| 11 | 876019 | INNER STOP RING | 1 |
| 12 | 876012 | OUTER LOWER BEARING | 1 |
| 13 | 876009 | INNER LOWER BEARING | 1 |
| 14 | 55925-444 | O-RING | 1 |
| 15 | 55929-444 | BACK-UP RING | 1 |
| 16 | 55931-444 | O-RING | 1 |
| 17 | 55932-263 | O-RING | 1 |
| 18 | 55924-750 | RETAINING RING | 1 |
| 19 | 55925-430 | O-RING | 1 |
| 20 | 55929-430 | BACK-UP RING | 1 |
| 21 | 55931-430 | O-RING | 1 |
| 22 | 55932-246 | O-RING | 1 |
| 23 | 55924-475 | RETAINING RING | 1 |
| 24 | 331-001 | SHSS, 1/2-20 x 1/2 LG | 1 |
| 25 | 331-002 | SHSS, 3/8-16 x 1/2 LG | 1 |

Parts List – Figure 3

When ordering replacement parts/kits, please specify model, serial number and color of your unit.

◆ PART OF REPAIR PARTS KIT

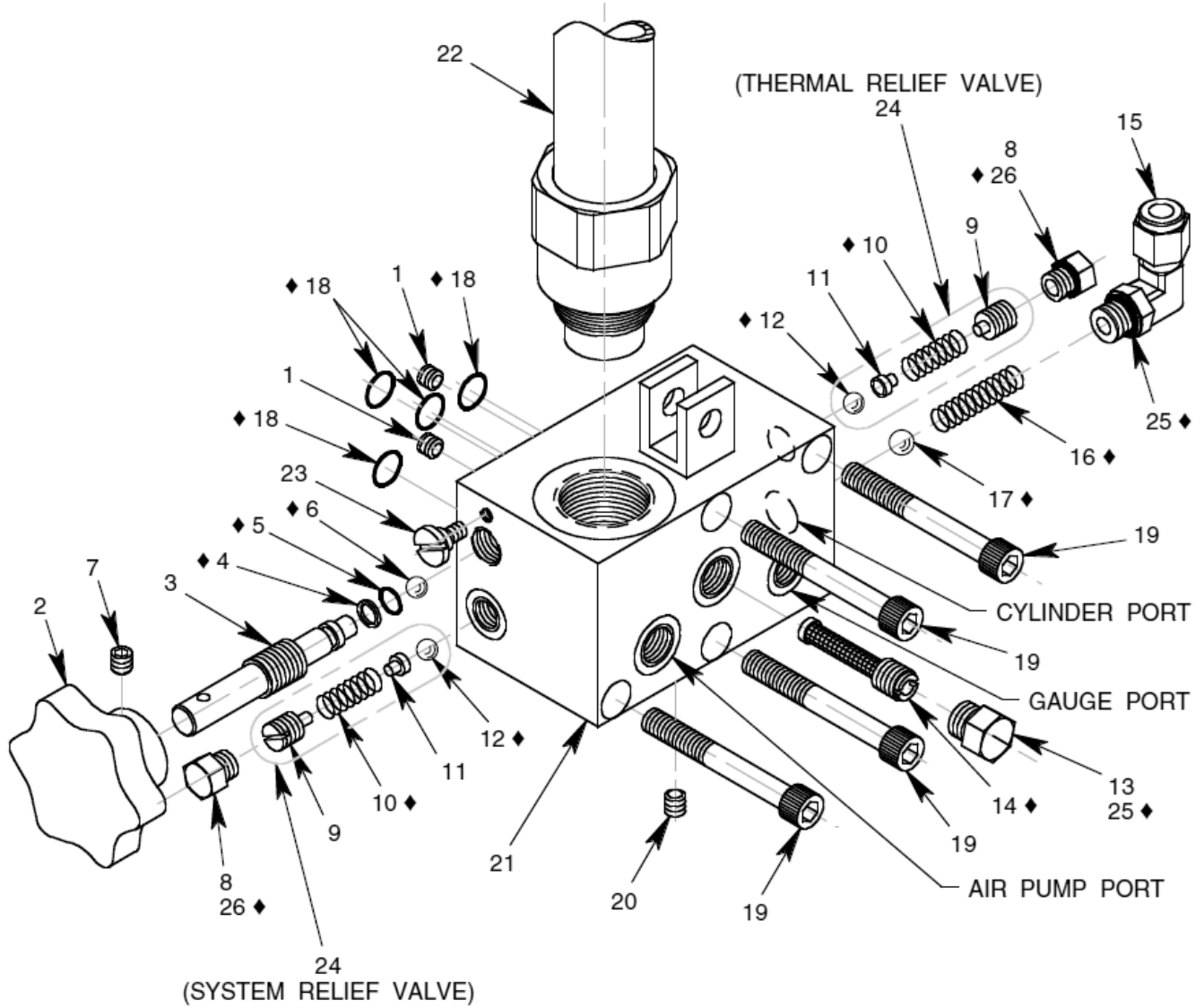

Parts List – Figure 3

When ordering replacement parts/kits, please specify model, serial number and color of your unit.

| Item | Part Number | Description | Qty |
|------|----------------|---|-----|
| | 56010-1 | Valve Block Assembly; consists of: | |
| 1 | 717-048 | PLUG, FLUSH, 1/16 MPT | 2 |
| 2 | 79366 | RELEASE VALVE KNOB | 1 |
| 3 | 79365 | RELEASE VALVE STEM | 1 |
| 4 | 55929-011 | BACK-UP RING | 1 |
| 5 | 55925-011 | O-RING | 1 |
| 6 | 412-002 | STEEL BALL, 5/16 DIA | 1 |
| 7 | 331-004 | SHSS, 5/16-24 x 5/16 LG | 1 |
| 8 | 717-001 | PLUG, 1/4 SAE O-RING | 2 |
| 9 | 55148 | SET SCREW | 2 |
| 10 | 55154H | SPRING | 2 |
| 11 | 55153 | GUIDE, SPRING | 2 |
| 12 | 412-004 | STEEL BALL, 1/4 DIA | 2 |
| 13 | 717-003 | PLUG, 3/8 SAE O-RING | 1 |
| 14 | 55568 | OIL SCREEN | 1 |
| 15 | 722-018 | ELBOW, 3/8 TUBE x 3/8 SAE O-RING | 1 |
| 16 | 79367 | SPRING | 1 |
| 17 | 412-001 | STEEL BALL, 3/8 DIA | 1 |
| 18 | 55925-014 | O-RING | 4 |
| 19 | 323-009 | SHCS, 3/8-24 x 3" LG | 4 |
| 20 | 717-010 | SOCKET PLUG, 1/16 MPT | 1 |
| 21 | 76345 | VALVE BLOCK WELDMENT | 1 |
| 22 | 79571-1 | HAND PUMP ASSEMBLY | 1 |
| 23 | 65228 | RELEASE VALVE LOCK SCREW | 1 |
| 24 | 55155 | SAFETY POP-OFF VALVE ASSY | 2 |
| 25 | MS28778-6 | O-RING (PART OF ITEMS 13 & 15) | 2 |
| 26 | MS28778-4 | O-RING (PART OF ITEM 8) | 2 |

Parts List – Figure 4

When ordering replacement parts/kits, please specify model, serial number and color of your unit.

◆ PART OF REPAIR PARTS KIT

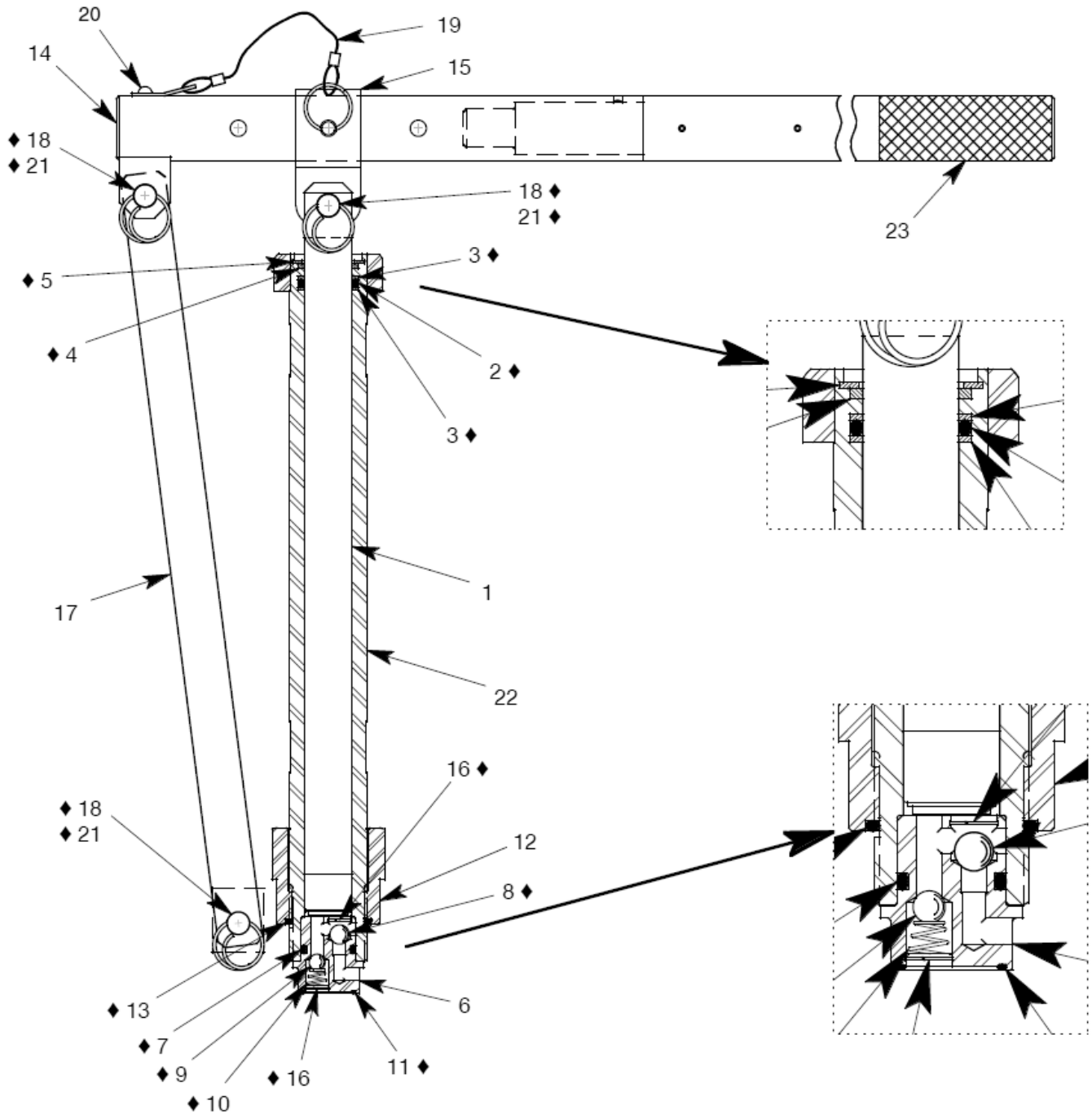

Parts List – Figure 4

When ordering replacement parts/kits, please specify model, serial number and color of your unit.

| Item | Part Number | Description | Qty |
|------|----------------|---|-----|
| | 79571-1 | Hand Pump Assembly; consists of: | |
| 1 | 55738 | PUMP PLUNGER | 1 |
| 2 | 55925-213 | O-RING | 1 |
| 3 | 55922-18 | BACK-UP RING | 2 |
| 4 | 55728 | SCRAPER RING | 1 |
| 5 | 55729 | RETAINING RING | 1 |
| 6 | 55753 | PUMP VALVE BODY | 1 |
| 7 | 55925-211 | O-RING | 1 |
| 8 | 412-001 | STEEL BALL, 3/8 DIA | 1 |
| 9 | 412-002 | STEEL BALL, 5/16 DIA | 1 |
| 10 | 55754 | DISCHARGE SPRING | 1 |
| 11 | 55925-021 | O-RING | 1 |
| 12 | 79564 | PUMP CYLINDER NUT | 1 |
| 13 | 55925-220 | O-RING | 1 |
| 14 | 55761 | PUMP FULCRUM | 1 |
| 15 | 55745 | CLAMP, PUMP HANDLE | 1 |
| 16 | 55927-43 | RETAINING RING | 2 |
| 17 | 55739 | FULCRUM LINK | 1 |
| 18 | 372-031 | COTTER RING | 3 |
| 19 | 370-001 | QUICK RELEASE PIN, 1/4 x 1.6 GRIP | 1 |
| 20 | MS51861-44C | SELF TAPPING SCREW | 1 |
| 21 | 373-001 | CLEVIS PIN, 7/16 DIA x 1" EFF LGTH | 3 |
| 22 | 79563 | PUMP CYCLINDER | 1 |
| 23 | 55762-7 | PUMP HANDLE | 1 |

Parts List – Figure 5

When ordering replacement parts/kits, please specify model, serial number and color of your unit.

*PARTS ARE LOCATED INSIDE RESERVOIR TANK

◆ PART OF REPAIR PARTS KIT

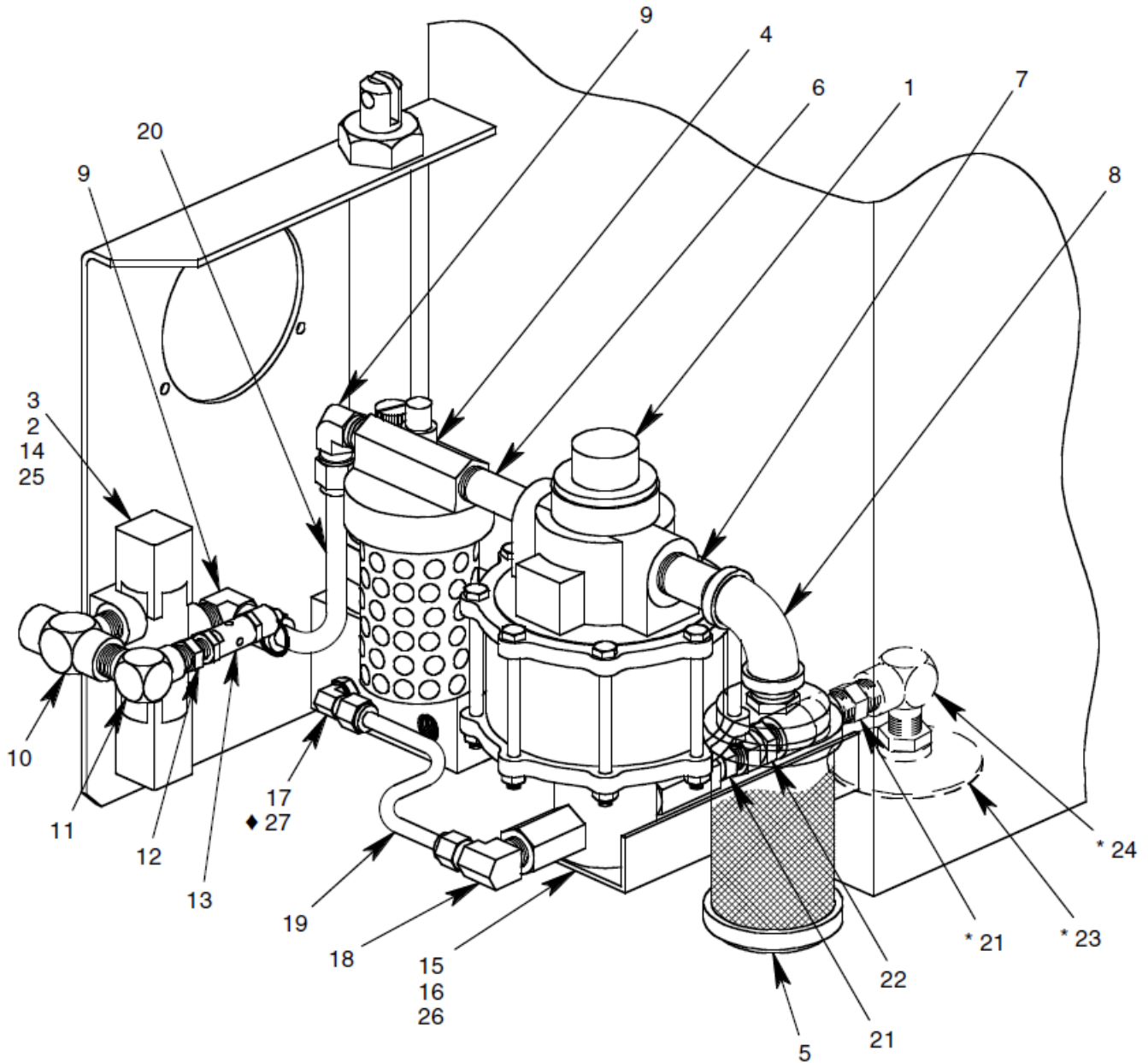

Parts List – Figure 5

When ordering replacement parts/kits, please specify model, serial number and color of your unit.

| Item | Part Number | Description | Qty |
|------|--------------|------------------------------------|-----|
| | 73176 | Air Pump Kit; consists of: | |
| 1 | 441-002 | AIR PUMP | 1 |
| 2 | 392-001 | STUD, 5/16-18 x 3/4 LG | 2 |
| 3 | 421-004 | AIR VALVE | 1 |
| 4 | 471-001 | LUBRICATOR | 1 |
| 5 | 499-001 | MUFFLER | 1 |
| 6 | 711-006 | NIPPLE, BRASS, 1/2 MPT x 3" LG | 1 |
| 7 | 711-010 | NIPPLE, BRASS, 3/4 x 3" LG | 1 |
| 8 | 712-063 | ELBOW, BRASS, 3/4 FPT | 1 |
| 9 | 722-013 | ELBOW, 1/2 TUBE x 1/2 MPT | 2 |
| 10 | 713-021 | TEE, BRANCH, 1/2 NPT | 1 |
| 11 | 712-032 | ELBOW, 1/2 MPT x 3/8 FPT | 1 |
| 12 | 714-009 | REDUCER, 3/8 MPT x 1/4 FPT | 1 |
| 13 | 425-001 | AIR RELIEF VALVE | 1 |
| 14 | 359-001 | ALLEN NUT, 5/16-18 | 2 |
| 15 | 321-013 | HHCS, 3/8-24 x 1" LG | 2 |
| 16 | 363-003 | SPLIT LOCKWASHER, 3/8 | 2 |
| 17 | 722-018 | ELBOW, 3/8 TUBE x 3/8 SAE O-RING | 1 |
| 18 | 722-015 | ELBOW, 3/8 TUBE x 1/2 MPT | 1 |
| 19 | 732-010 | TUBE, 3/8 OD x .065 WALL x 36" LG | AR |
| 20 | 732-001 | TUBE, 1/2 OD x .049 WALL x 12" LG | AR |
| 21 | 711-004 | NIPPLE, 1/2 MPT | 2 |
| 22 | 719-001 | ADAPTER, SWIVEL, 1/2 MPT x 1/2 FPT | 1 |
| 23 | 481-001 | OIL SCREEN | 1 |
| 24 | 712-011 | ELBOW, STREET, 1/2 NPT | 1 |
| 25 | 363-002 | SPLIT LOCKWASHER, 5/16 | 2 |
| 26 | 361-001 | FLAT WASHER, 3/8 | 2 |
| 27 | MS28778-6 | O-RING (PART OF ITEM 17) | 1 |

Parts List – Figure 6

When ordering replacement parts/kits, please specify model, serial number and color of your unit.

◆ PART OF REPAIR PARTS KIT

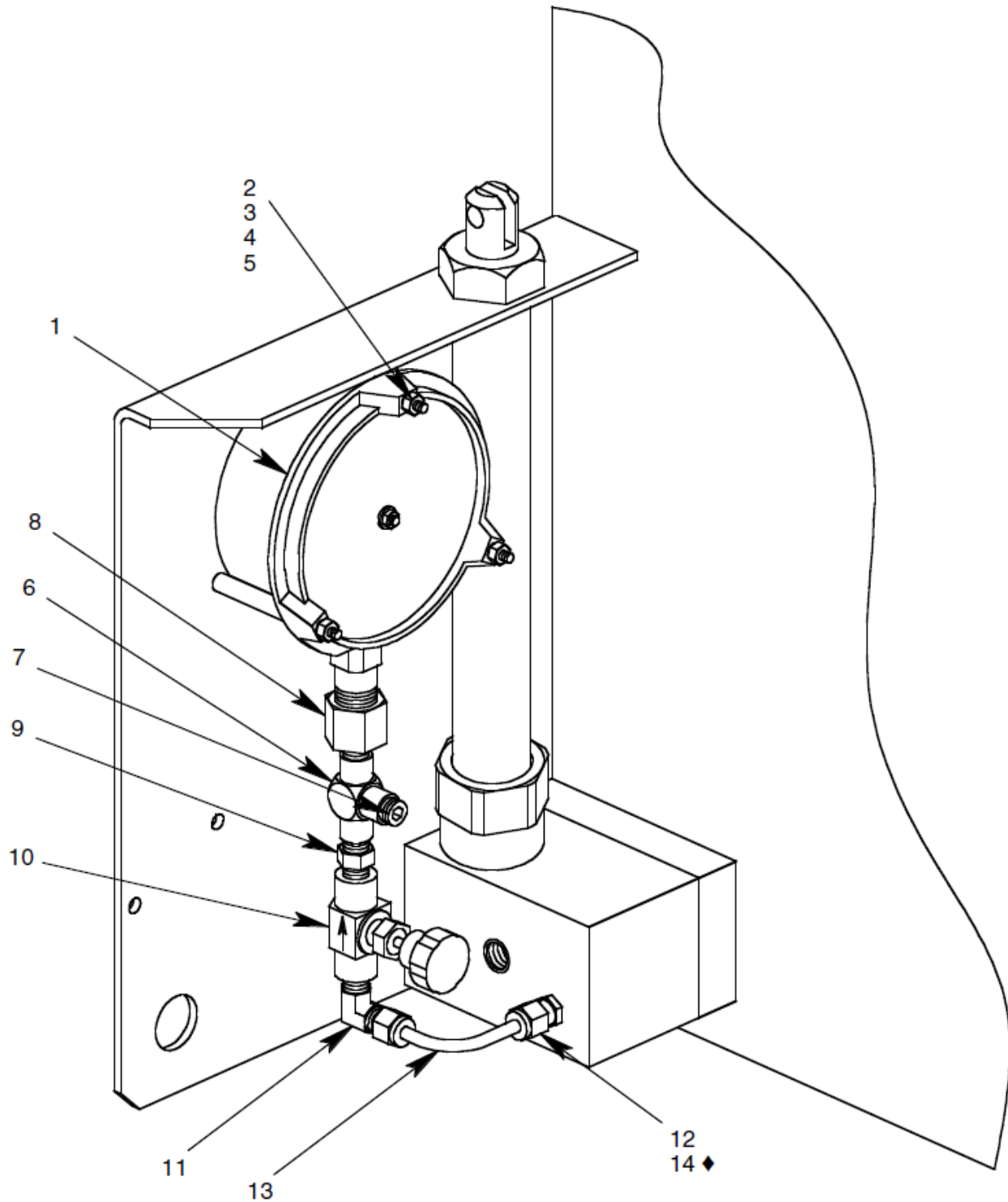

Parts List – Figure 6

When ordering replacement parts/kits, please specify model, serial number and color of your unit.

| Item | Part Number | Description | Qty |
|------|---------------|--------------------------------------|-----|
| | 876014 | Load Gauge Kit; consists of: | |
| 1 | 876015 | LOAD GAUGE | 1 |
| 2 | 323-072 | SHCS, 10-32 x 3-1/2 LG | 3 |
| 3 | 363-009 | SPLIT LOCKWASHER, #10 | 3 |
| 4 | 351-008 | HEX NUT, 10-32 | 3 |
| 5 | 876025 | GAUGE SPACER | 3 |
| 6 | 713-002 | TEE, 1/4 FPT | 1 |
| 7 | 717-006 | PLUG, 1/4 MPT | 1 |
| 8 | 714-001 | REDUCER, 1/2 FPT x 1/4 MPT | 1 |
| 9 | 711-003 | NIPPLE, 1/4 MPT | 1 |
| 10 | 424-001 | SHUTOFF VALVE | 1 |
| 11 | 722-021 | ELBOW, 1/4 TUBE x 1/4 MPT | 1 |
| 12 | 721-011 | CONNECTOR, 1/4 TUBE x 1/4 SAE O-RING | 1 |
| 13 | 732-003 | TUBE, 1/4 OD x .035 WALL x 12" LG | AR |
| 14 | MS28778-4 | O-RING (PART OF ITEM 12) | 1 |

Parts List – Figure 7

When ordering replacement parts/kits, please specify model, serial number and color of your unit.

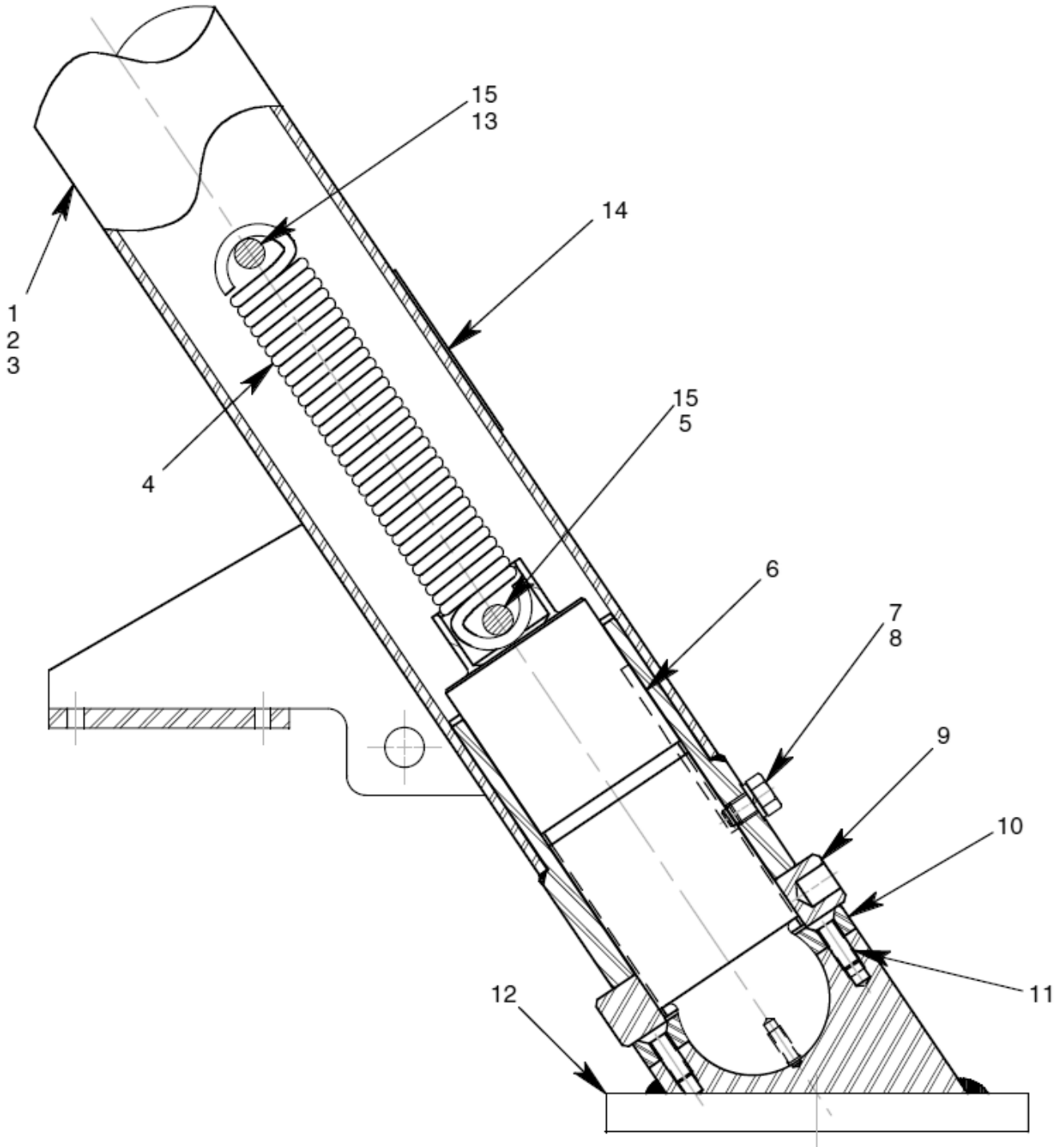

Parts List – Figure 7

When ordering replacement parts/kits, please specify model, serial number and color of your unit.

| Item | Part Number | Description | Qty |
|------|---------------|---|-----|
| | 876045 | Adjustable Foot Kit Assembly; consists of: | |
| 1 | 876046 | TRIPOD LEG | 1 |
| 2 | 876047 | TRIPOD LEG w/ TOW BRKT | 1 |
| 3 | 876049 | TRIPOD LEG w/ HANDLE HLDR | 1 |
| 4 | 79344 | SPRING | 3 |
| 5 | 79348 | SHORT SPRING PIN | 3 |
| 6 | 79339 | FOOT SCREW | 3 |
| 7 | 363-005 | SPLIT LOCKWASHER, 5/8 | 3 |
| 8 | 79347 | GUIDE SCREW, 5/8-11 | 3 |
| 9 | 79343 | LOCKNUT | 3 |
| 10 | 79346 | RETAINING RING | 3 |
| 11 | 325-001 | FSHCS, 1/2-13 x 1 1/2 LG | 18 |
| 12 | 876021 | FOOT | 3 |
| 13 | 79345 | LONG SPRING PIN | 3 |
| 14 | 75941 | STICKER, FOOTPAD | 3 |
| 15 | 55923-75 | RETAINING RING | 12 |

Parts List – Figure 8

When ordering replacement parts/kits, please specify model, serial number and color of your unit.

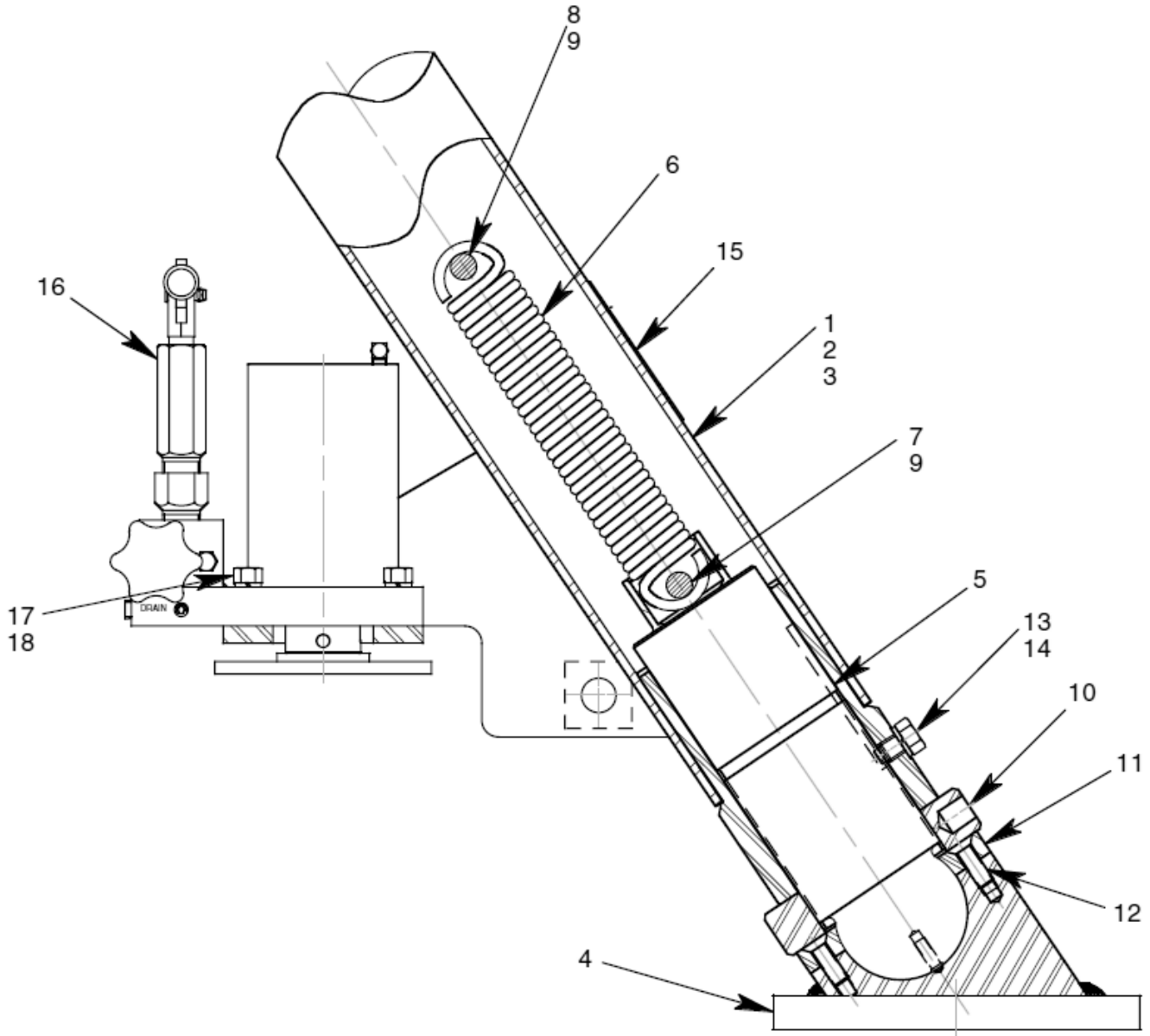

Parts List – Figure 8

When ordering replacement parts/kits, please specify model, serial number and color of your unit.

| Item | Part Number | Description | Qty |
|------|---------------|---|-----|
| | 876068 | Adjustable Foot Kit with Hydraulic Caster Assembly; consists of: | |
| 1 | 876075 | TRIPOD LEG WELDMENT | 1 |
| 2 | 876076 | TRIPOD LEG w/ HANDLE BRKT | 1 |
| 3 | 876080 | TRIPOD LEG w/ HANDLE HLDR | 1 |
| 4 | 876021 | FOOT WELDMENT | 3 |
| 5 | 79339 | FOOT SCREW | 3 |
| 6 | 79344 | SPRING | 3 |
| 7 | 79348 | SHORT PIN | 3 |
| 8 | 79345 | LONG PIN | 3 |
| 9 | 55923-75 | RETAINING RING | 12 |
| 10 | 79343 | LOCKNUT | 3 |
| 11 | 79346 | RETAINING RING | 3 |
| 12 | 325-001 | FSHCS, 1/2-13 x 1 1/2 LG | 18 |
| 13 | 79347 | GUIDE SCREW, 5/8-11 | 3 |
| 14 | 363-005 | SPLIT LOCKWASHER, 5/8 | 3 |
| 15 | 75941 | STICKER, FOOTPAD | 3 |
| 16 | 881800 | HYDRAULIC CASTER ASSEMBLY | 3 |
| 17 | 321-005 | HHCS, 1/2-13 x 2" LG | 12 |
| 18 | 363-004 | SPLIT LOCKWASHER, 1/2 | 12 |

Parts List – Figure 9

When ordering replacement parts/kits, please specify model, serial number and color of your unit.

♣ PART OF HYDRAULIC CASTER REPAIR KIT

*APPLY LOCKTITE NO. 242 ON THREADS

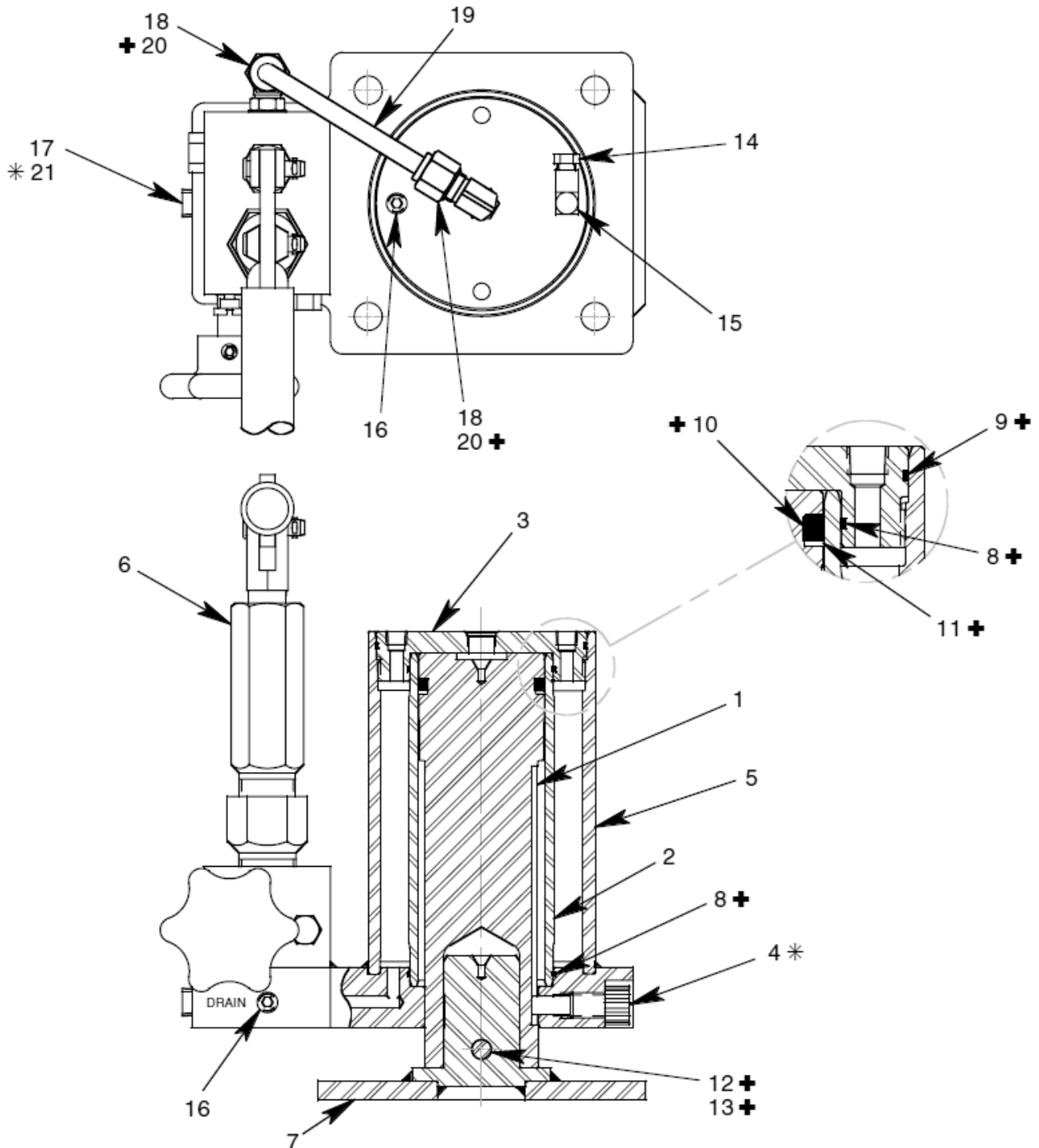

Parts List – Figure 9

When ordering replacement parts/kits, please specify model, serial number and color of your unit.

| Item | Part Number | Description | Qty |
|------|---------------|--|-----|
| | 881800 | Hydraulic Caster Assembly; consists of: | |
| 1 | 881803 | PLUNGER | 1 |
| 2 | 881804 | CYLINDER | 1 |
| 3 | 881805 | CYLINDER / RESERVOIR CAP | 1 |
| 4 | 881806 | RETAINING SCREW | 1 |
| 5 | 881807 | RESERVOIR / BASE WELDMENT | 1 |
| 6 | 881808 | VALVE BLOCK AND HAND PUMP ASSEMBLY | 1 |
| 7 | 881809 | CASTER MOUNTING PLATE WELDMENT | 1 |
| 8 | 55925-040 | O-RING | 2 |
| 9 | 55925-045 | O-RING | 1 |
| 10 | 55925-330 | O-RING | 1 |
| 11 | 55929-330 | BACK-UP RING | 1 |
| 12 | 372-009 | COTTER PIN, 3/32 DIA x 1/2 LG | 1 |
| 13 | 373-005 | FLAT HEAD PIN, 3/8 DIA x 2 9/32 LG | 1 |
| 14 | 483-006 | BREATHER, 1/8 MPT | 1 |
| 15 | 712-060 | ELBOW, 1/8 MPT x 1/8 FPT | 1 |
| 16 | 717-005 | PLUG, 1/8 MPT | 2 |
| 17 | 717-006 | PLUG, 1/4 MPT | 1 |
| 18 | 722-018 | ELBOW, 3/8 TUBE x 3/8 SAE O-RING | 2 |
| 19 | 732-024 | TUBE, 3/8 OD x .035 WALL x 12" LG | AR |
| 20 | MS28778-6 | O-RING (PART OF ITEM 18) | 2 |
| 21 | 881817 | SETSCREW ORIFICE | 1 |

Parts List – Figure 10

When ordering replacement parts/kits, please specify model, serial number and color of your unit.

♣ PART OF HYDRAULIC CASTER REPAIR KIT

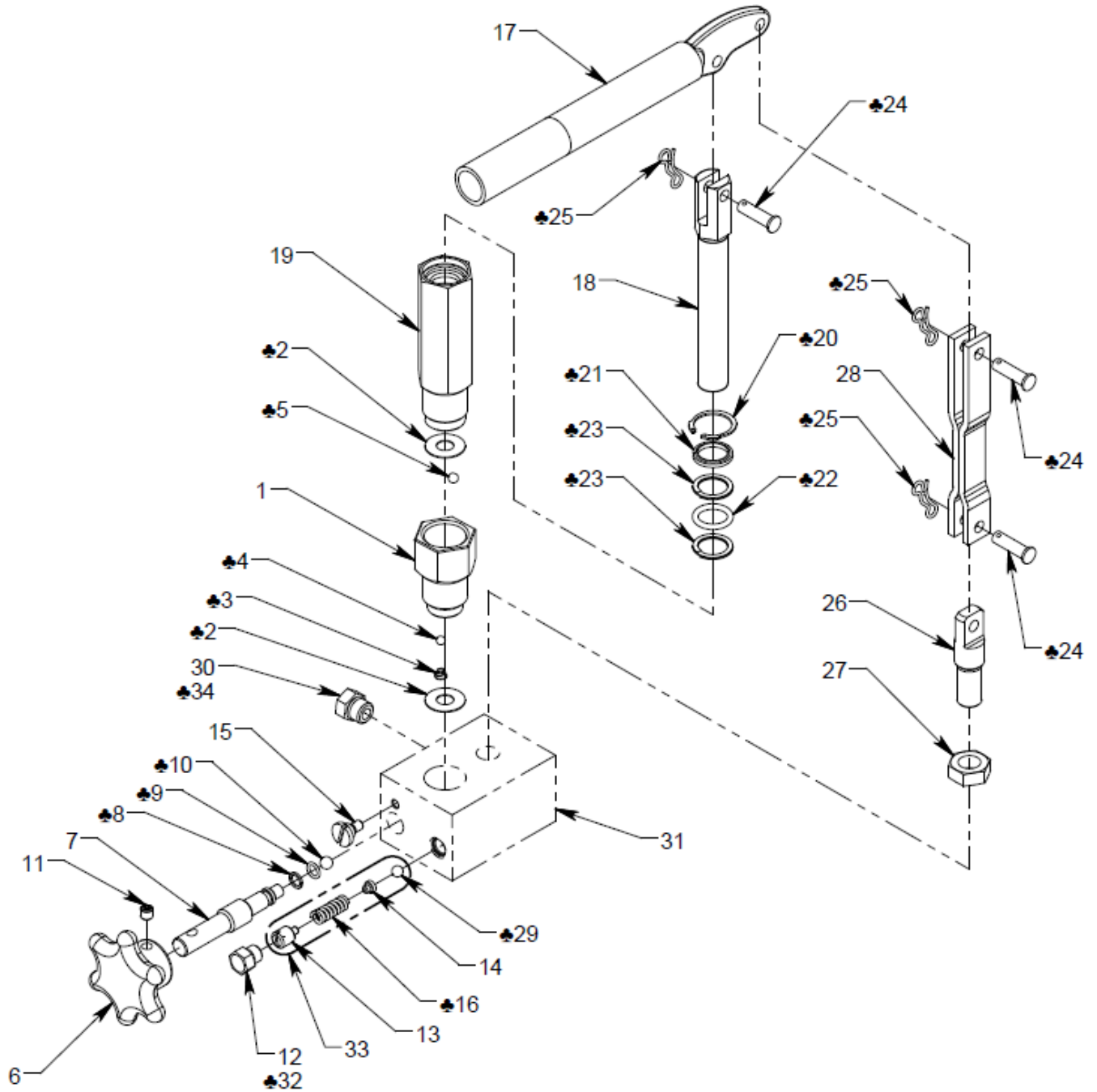

Parts List – Figure 10

When ordering replacement parts/kits, please specify model, serial number and color of your unit.

| Item | Part Number | Description | Qty |
|------|---------------|---|-----|
| | 881808 | Valve Block and Hand Pump Assembly; consists of: | |
| 1 | 55010 | BLOCK VALVE | 1 |
| 2 | 55024 | GASKET | 2 |
| 3 | 55295 | SPRING, PUMP | 1 |
| 4 | 412-003 | STEEL BALL, 7/32 DIA | 1 |
| 5 | 412-004 | STEEL BALL, 1/4 DIA | 1 |
| 6 | 79366 | RELEASE VALVE KNOB | 1 |
| 7 | 79365 | RELEASE VALVE STEM | 1 |
| 8 | 55929-011 | BACK-UP RING | 1 |
| 9 | 55925-011 | O-RING | 1 |
| 10 | 412-002 | STEEL BALL, 5/16 DIA | 1 |
| 11 | 331-004 | SHSS, 5/16-24 x 5/16 LG | 1 |
| 12 | 717-001 | PLUG, 1/4 SAE O-RING | 1 |
| 13 | 55148 | SET SCREW | 1 |
| 14 | 55153 | GUIDE, SPRING | 1 |
| 15 | 65228 | RELEASE VALVE LOCK SCREW | 1 |
| 16 | 495-048 | SPRING | 1 |
| 17 | 881815 | FULCRUM WELDMENT | 1 |
| 18 | 881847 | PLUNGER, 3/4 DIA | 1 |
| 19 | 881846 | BODY, 3/4 DIA | 1 |
| 20 | 55926-112 | RETAINING RING | 1 |
| 21 | 55911-15 | SCRAPER RING | 1 |
| 22 | 55925-210 | O-RING | 1 |
| 23 | 55922-15 | BACK-UP RING | 2 |
| 24 | 55002 | PUMP PIN | 3 |
| 25 | 372-028 | BOW TIE COTTER | 3 |
| 26 | 55011 | ANCHOR | 1 |
| 27 | 352-004 | HEX JAM NUT, 5/8-18 | 1 |
| 28 | 55012 | PUMP LINK | 1 |
| 29 | 412-007 | STEEL BALL, 9/32 DIA | 1 |
| 30 | 717-003 | PLUG, 3/8 SAE O-RING | 1 |
| 31 | 881807 | RESERVOIR / BASE WELDMENT | REF |
| 32 | MS28778-4 | O-RING (PART OF ITEM 12) | 1 |
| 33 | 881816 | SAFETY POP-OFF VALVE ASSY | 1 |
| 34 | MS28778-6 | O-RING (PART OF ITEM 30) | 1 |

Parts List – Figure 11

When ordering replacement parts/kits, please specify model, serial number and color of your unit.

*37° FLARE END OF ITEM 2 TO BE INSERTED INTO ITEM 1

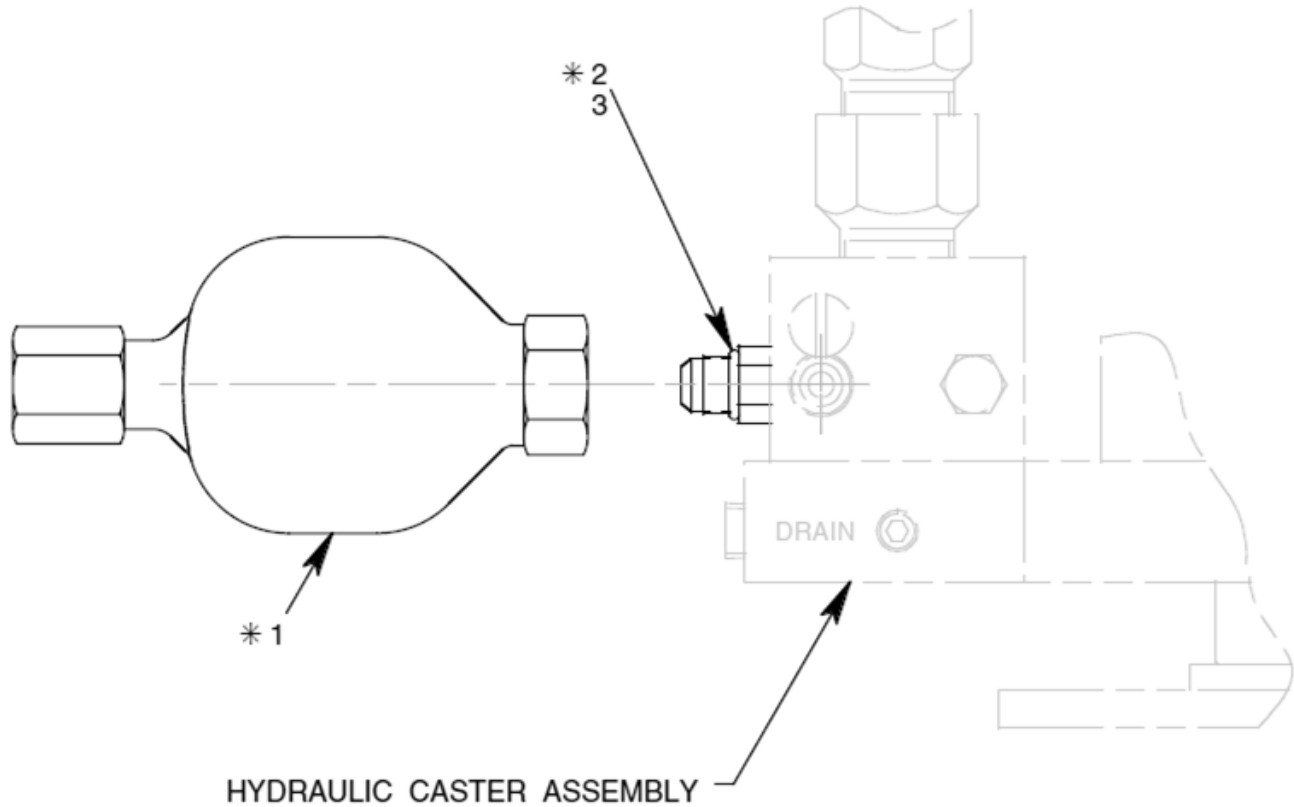

| Item | Part Number | Description | Qty |
|------|---------------|--|-----|
| | 881818 | Shock Absorber Kit Assembly; consists of: | |
| 1 | 490-029 | DIAPHRAGM ACCUMULATOR | 3 |
| 2 | 721-040 | CONN., 3/8 MALE 37° x 3/8 SAE O-RING | 3 |
| 3 | MS28778-6 | O-RING | 6 |

Parts List – Figure 12

When ordering replacement parts/kits, please specify model, serial number and color of your unit.

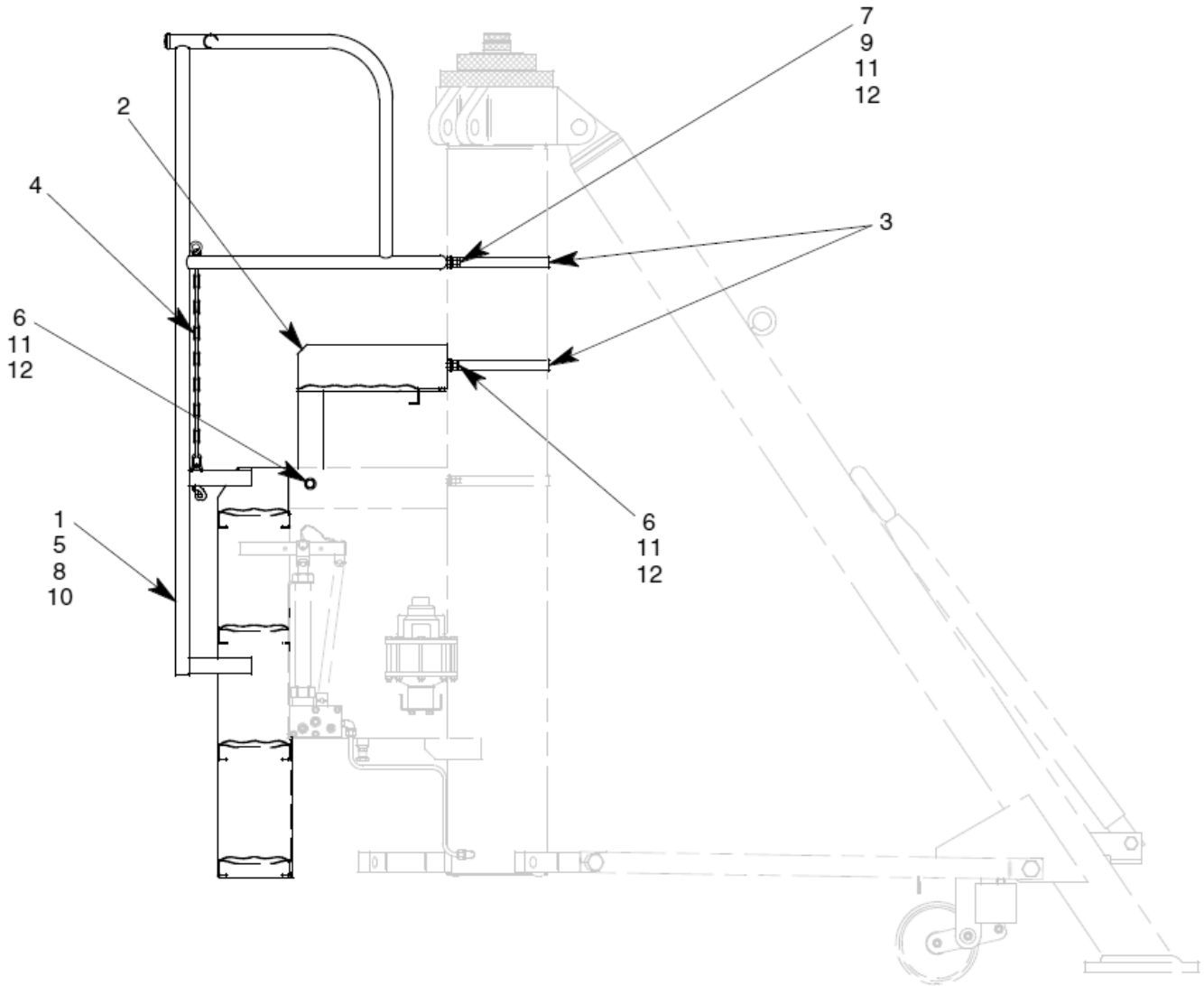

| Item | Part Number | Description | Qty |
|------|---------------|--|-----|
| | 876060 | Ladder Kit Assembly; consists of: | |
| 1 | 876050 | LADDER | 1 |
| 2 | 876051 | PLATFORM | 1 |
| 3 | 876031 | STRAP | 2 |
| 4 | 76378 | SAFETY CHAIN ASSEMBLY | 1 |
| 5 | 321-011 | HHCS, 3/8-16 x 1" LG | 4 |
| 6 | 321-014 | HHCS, 1/2-13 x 1 1/2 LG | 4 |
| 7 | 321-139 | HHCS, 1/2-13 x 2 3/4 LG | 2 |
| 8 | 362-003 | FLAT WASHER, 3/8 SAE | 4 |
| 9 | 362-005 | FLAT WASHER, 1/2 SAE | 12 |
| 10 | 363-003 | SPLIT LOCKWASHER, 3/8 | 4 |
| 11 | 363-004 | SPLIT LOCKWASHER, 1/2 | 6 |
| 12 | 351-003 | HEX NUT, 1/2-13 | 6 |

Parts List – Figure 13

When ordering replacement parts/kits, please specify model, serial number and color of your unit.

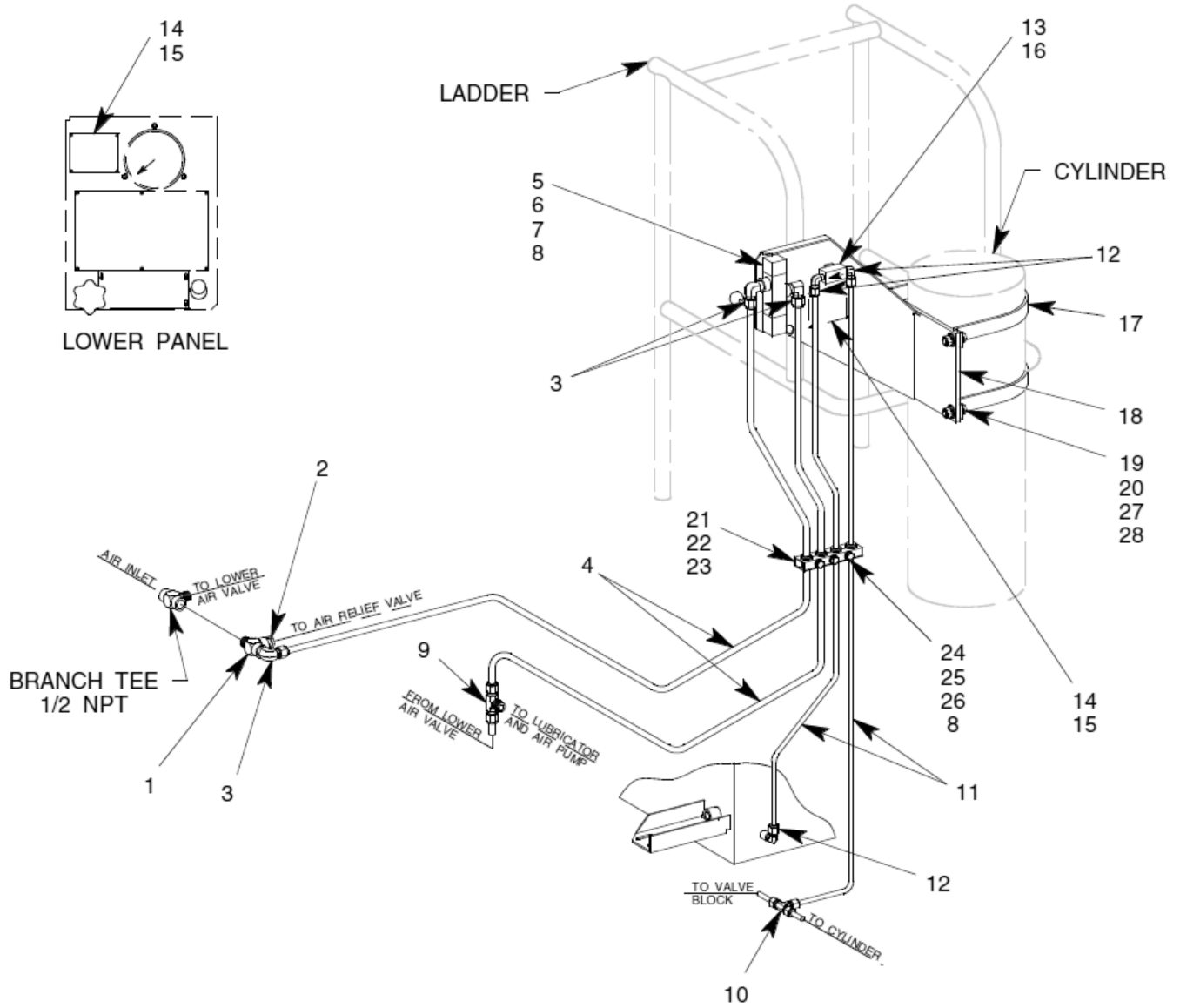

Parts List – Figure 13

When ordering replacement parts/kits, please specify model, serial number and color of your unit.

| Item | Part Number | Description | Qty |
|------|---------------|--|-----|
| | 876090 | Remote Control Kit Assembly; consists of: | |
| 1 | 713-029 | TEE, RUN, 1/2 NPT | 1 |
| 2 | 714-003 | REDUCER, 1/2 MPT x 1/4 FPT | 1 |
| 3 | 722-013 | ELBOW, 1/2 TUBE x 1/2 MPT | 3 |
| 4 | 732-001 | TUBE, 1/2 OD x .049 WALL x 130" LG | AR |
| 5 | 421-004 | AIR VALVE | 1 |
| 6 | 392-001 | STUD, 5/16-18 x 3/4 LG | 2 |
| 7 | 359-001 | ALLEN NUT, 5/16-18 | 2 |
| 8 | 363-002 | SPLIT LOCKWASHER, 5/16 | 5 |
| 9 | 723-033 | TEE, BRANCH, 1/2 TUBE X 1/2 MPT | 1 |
| 10 | 723-007 | TEE, 3/8 TUBE | 1 |
| 11 | 732-010 | TUBE, 3/8 OD x .065 WALL x 120" LG | AR |
| 12 | 722-014 | ELBOW, 3/8 TUBE x 1/4 MPT | 3 |
| 13 | 85416 | RELEASE VALVE | 1 |
| 14 | 76158 | CAUTION PLACARD | 2 |
| 15 | 397-010 | SELF TAPPING SCREW, #6-32 x 3/16 LG | 8 |
| 16 | 491-044 | SAFETY LOCK WIRE, .025 DIA | AR |
| 17 | 876031 | STRAP | 2 |
| 18 | 876089 | PANEL | 1 |
| 19 | 321-014 | HHCS, 1/2-13 x 1 1/2 LG | 4 |
| 20 | 363-004 | SPLIT LOCKWASHER, 1/2 | 4 |
| 21 | 394-033 | SPLIT BUSHING, 1/2 TUBE | 2 |
| 22 | 394-034 | SPLIT BUSHING, 3/8 TUBE | 2 |
| 23 | 394-031 | CLAMPING UNIT | 1 |
| 24 | 321-080 | HHCS, 5/16-18 x 2" LG | 3 |
| 25 | 362-002 | FLAT WASHER, 5/16 | 3 |
| 26 | 351-012 | HEX NUT, 5/16-18 | 3 |
| 27 | 351-003 | HEX NUT, 1/2-13 | 4 |
| 28 | 362-005 | FLAT WASHER, 1/2 SAE | 8 |



APPENDIX I

Safety Data Sheet MIL-PRF-5606 Hydraulic Fluid

Product Name: MOBIL AERO HFA
Revision Date: 01 Oct 2015
Page 1 of 12

SAFETY DATA SHEET

SECTION 1**PRODUCT AND COMPANY IDENTIFICATION****PRODUCT**

Product Name: MOBIL AERO HFA
Product Description: Base Oil and Additives
Product Code: 201550401020, 490110-00, 970584
Intended Use: Aviation hydraulic oil

COMPANY IDENTIFICATION

Supplier: EXXON MOBIL CORPORATION
22777 Springwoods Village Parkway
Spring, TX. 77253 USA

24 Hour Health Emergency 609-737-4411
Transportation Emergency Phone 800-424-9300 or 703-527-3887 CHEMTREC
Product Technical Information 800-662-4525
MSDS Internet Address <http://www.exxon.com>, <http://www.mobil.com>

SECTION 2**HAZARDS IDENTIFICATION**

This material is hazardous according to regulatory guidelines (see (M)SDS Section 15).

CLASSIFICATION:

Flammable liquid: Category 4.
Aspiration toxicant: Category 1.

LABEL:

Pictogram:



Signal Word: Danger

Hazard Statements:

H227: Combustible liquid. H304: May be fatal if swallowed and enters airways.

Precautionary Statements:

P210: Keep away from flames and hot surfaces. -- No smoking. P273: Avoid release to the environment. P280: Wear protective gloves and eye / face protection. P301 + P310: IF SWALLOWED: Immediately call a POISON CENTER or doctor/physician. P331: Do NOT induce vomiting. P370 + P378: In case of fire: Use water fog, foam, dry chemical or carbon dioxide (CO2) to extinguish. P403 + P235: Store in a well-ventilated place. Keep cool. P405: Store locked up. P501: Dispose of contents and container in accordance with local regulations.

Product Name: MOBIL AERO HFA
 Revision Date: 01 Oct 2015
 Page 2 of 12

Other hazard information:

HAZARD NOT OTHERWISE CLASSIFIED (HNOC): None as defined under 29 CFR 1910.1200.

PHYSICAL / CHEMICAL HAZARDS

Material can accumulate static charges which may cause an ignition. Material can release vapors that readily form flammable mixtures. Vapor accumulation could flash and/or explode if ignited. Combustible.

HEALTH HAZARDS

High-pressure injection under skin may cause serious damage. Excessive exposure may result in eye, skin, or respiratory irritation.

ENVIRONMENTAL HAZARDS

No significant hazards.

| | | | |
|------------------------|------------|-----------------|---------------|
| NFPA Hazard ID: | Health: 1 | Flammability: 2 | Reactivity: 0 |
| HMIS Hazard ID: | Health: 1* | Flammability: 2 | Reactivity: 0 |

NOTE: This material should not be used for any other purpose than the intended use in Section 1 without expert advice. Health studies have shown that chemical exposure may cause potential human health risks which may vary from person to person.

| | |
|------------------|---|
| SECTION 3 | COMPOSITION / INFORMATION ON INGREDIENTS |
|------------------|---|

This material is defined as a mixture.

Hazardous Substance(s) or Complex Substance(s) required for disclosure

| Name | CAS# | Concentration* | GHS Hazard Codes |
|--|------------|----------------|---------------------------------------|
| 2,6-DI-TERT-BUTYL-P-CRESOL | 128-37-0 | 0.1 - < 1% | H400(M factor 1), H410(M factor 1) |
| DISTILLATES (PETROLEUM), HYDROTREATED LIGHT | 64742-47-8 | 5 - < 10% | H304 |
| HYDROTREATED LIGHT NAPHTHENIC DISTILLATE (PETROLEUM) | 64742-53-6 | 50 - < 70% | H227, H304 |
| HYDROTREATED MIDDLE DISTILLATE (PETROLEUM) | 64742-46-7 | 20 - < 30% | H304 |
| TRIPHENYL PHOSPHATE | 115-86-6 | 0.1 - < 0.25% | H400(M factor 1), H410(M factor 1) |

* All concentrations are percent by weight unless material is a gas. Gas concentrations are in percent by volume.

As per paragraph (i) of 29 CFR 1910.1200, formulation is considered a trade secret and specific chemical identity and exact percentage (concentration) of composition may have been withheld. Specific chemical identity and exact percentage composition will be provided to health professionals, employees, or designated representatives in accordance with applicable provisions of paragraph (i).

| | |
|------------------|---------------------------|
| SECTION 4 | FIRST AID MEASURES |
|------------------|---------------------------|

INHALATION

Remove from further exposure. For those providing assistance, avoid exposure to yourself or others. Use adequate respiratory protection. If respiratory irritation, dizziness, nausea, or unconsciousness occurs, seek immediate medical assistance. If breathing has stopped, assist ventilation with a mechanical device or use mouth-to-mouth resuscitation.

SKIN CONTACT

Wash contact areas with soap and water. Remove contaminated clothing. Launder contaminated clothing before reuse. If product is injected into or under the skin, or into any part of the body, regardless of the appearance of the wound or its size, the individual should be evaluated immediately by a physician as a surgical emergency. Even though initial symptoms from high pressure injection may be minimal or absent, early surgical treatment within the first few hours may significantly reduce the ultimate extent of injury.

EYE CONTACT

Flush thoroughly with water. If irritation occurs, get medical assistance.

INGESTION

Seek immediate medical attention. Do not induce vomiting.

NOTE TO PHYSICIAN

If ingested, material may be aspirated into the lungs and cause chemical pneumonitis. Treat appropriately.

SECTION 5 FIRE FIGHTING MEASURES

EXTINGUISHING MEDIA

Appropriate Extinguishing Media: Use water fog, foam, dry chemical or carbon dioxide (CO₂) to extinguish flames.

Inappropriate Extinguishing Media: Straight Streams of Water

FIRE FIGHTING

Fire Fighting Instructions: Evacuate area. Prevent runoff from fire control or dilution from entering streams, sewers, or drinking water supply. Firefighters should use standard protective equipment and in enclosed spaces, self-contained breathing apparatus (SCBA). Use water spray to cool fire exposed surfaces and to protect personnel.

Unusual Fire Hazards: Combustible. Pressurized mists may form a flammable mixture.

Hazardous Combustion Products: Aldehydes, Incomplete combustion products, Oxides of carbon, Phosphorus oxides, Smoke, Fume, Sulfur oxides

FLAMMABILITY PROPERTIES

Flash Point [Method]: >82°C (180°F) [ASTM D-93]

Flammable Limits (Approximate volume % in air): LEL: 0.7 UEL: 7.0 [Estimated]

Autoignition Temperature: >225°C (437°F)

SECTION 6 ACCIDENTAL RELEASE MEASURES

NOTIFICATION PROCEDURES

In the event of a spill or accidental release, notify relevant authorities in accordance with all applicable

regulations. US regulations require reporting releases of this material to the environment which exceed the applicable reportable quantity or oil spills which could reach any waterway including intermittent dry creeks. The National Response Center can be reached at (800)424-8802.

PROTECTIVE MEASURES

Avoid contact with spilled material. Warn or evacuate occupants in surrounding and downwind areas if required due to toxicity or flammability of the material. See Section 5 for fire fighting information. See the Hazard Identification Section for Significant Hazards. See Section 4 for First Aid Advice. See Section 8 for advice on the minimum requirements for personal protective equipment. Additional protective measures may be necessary, depending on the specific circumstances and/or the expert judgment of the emergency responders.

For emergency responders: Respiratory protection: respiratory protection will be necessary only in special cases, e.g., formation of mists. Half-face or full-face respirator with filter(s) for dust/organic vapor or Self Contained Breathing Apparatus (SCBA) can be used depending on the size of spill and potential level of exposure. If the exposure cannot be completely characterized or an oxygen deficient atmosphere is possible or anticipated, SCBA is recommended. Work gloves that are resistant to hydrocarbons are recommended. Gloves made of polyvinyl acetate (PVA) are not water-resistant and are not suitable for emergency use. Chemical goggles are recommended if splashes or contact with eyes is possible. Small spills: normal antistatic work clothes are usually adequate. Large spills: full body suit of chemical resistant, antistatic material is recommended.

SPILL MANAGEMENT

Land Spill: Eliminate all ignition sources (no smoking, flares, sparks or flames in immediate area). Stop leak if you can do it without risk. All equipment used when handling the product must be grounded. Do not touch or walk through spilled material. Prevent entry into waterways, sewer, basements or confined areas. A vapor suppressing foam may be used to reduce vapors. Use clean non-sparking tools to collect absorbed material. Absorb or cover with dry earth, sand or other non-combustible material and transfer to containers. Large Spills: Water spray may reduce vapor; but may not prevent ignition in closed spaces. Recover by pumping or with suitable absorbent.

Water Spill: Stop leak if you can do it without risk. Confine the spill immediately with booms. Warn other shipping. Remove from the surface by skimming or with suitable absorbents. Seek the advice of a specialist before using dispersants.

Water spill and land spill recommendations are based on the most likely spill scenario for this material; however, geographic conditions, wind, temperature, (and in the case of a water spill) wave and current direction and speed may greatly influence the appropriate action to be taken. For this reason, local experts should be consulted. Note: Local regulations may prescribe or limit action to be taken.

ENVIRONMENTAL PRECAUTIONS

Large Spills: Dike far ahead of liquid spill for later recovery and disposal. Prevent entry into waterways, sewers, basements or confined areas.

| | |
|------------------|-----------------------------|
| SECTION 7 | HANDLING AND STORAGE |
|------------------|-----------------------------|

HANDLING

Avoid contact with skin. Avoid prolonged breathing of mists and heated vapor. Prevent small spills and leakage to avoid slip hazard. Material can accumulate static charges which may cause an electrical spark (ignition source). When the material is handled in bulk, an electrical spark could ignite any flammable vapors from liquids or residues that may be present (e.g., during switch-loading operations). Use proper bonding and/or ground procedures. However, bonding and grounds may not eliminate the hazard from static

accumulation. Consult local applicable standards for guidance. Additional references include American Petroleum Institute 2003 (Protection Against Ignitions Arising out of Static, Lightning and Stray Currents) or National Fire Protection Agency 77 (Recommended Practice on Static Electricity) or CENELEC CLC/TR 50404 (Electrostatics - Code of practice for the avoidance of hazards due to static electricity).

Static Accumulator: This material is a static accumulator.

STORAGE

The container choice, for example storage vessel, may effect static accumulation and dissipation. Keep container closed. Handle containers with care. Open slowly in order to control possible pressure release. Store in a cool, well-ventilated area. Storage containers should be grounded and bonded. Fixed storage containers, transfer containers and associated equipment should be grounded and bonded to prevent accumulation of static charge.

SECTION 8 EXPOSURE CONTROLS / PERSONAL PROTECTION

EXPOSURE LIMIT VALUES

Exposure limits/standards (Note: Exposure limits are not additive)

| Substance Name | Form | Limit / Standard | | NOTE | Source |
|---|------------------------------|------------------|-----------|------|---------|
| 2,6-DI-TERT-BUTYL-P-CRESOL | Inhalable fraction and vapor | TWA | 2 mg/m3 | N/A | ACGIH |
| DISTILLATES (PETROLEUM), HYDROTREATED LIGHT [total hydrocarbon vapor] | Non-Aerosol | TWA | 200 mg/m3 | Skin | ACGIH |
| HYDROTREATED LIGHT NAPHTHENIC DISTILLATE (PETROLEUM) | Mist. | TWA | 5 mg/m3 | N/A | OSHA Z1 |
| HYDROTREATED LIGHT NAPHTHENIC DISTILLATE (PETROLEUM) | Inhalable fraction. | TWA | 5 mg/m3 | N/A | ACGIH |
| HYDROTREATED LIGHT NAPHTHENIC DISTILLATE (PETROLEUM) | Mist. | TWA | 5 mg/m3 | N/A | ACGIH |
| HYDROTREATED MIDDLE DISTILLATE (PETROLEUM) | Mist. | TWA | 5 mg/m3 | N/A | OSHA Z1 |
| HYDROTREATED MIDDLE DISTILLATE (PETROLEUM) | Inhalable fraction. | TWA | 5 mg/m3 | N/A | ACGIH |
| TRIPHENYL PHOSPHATE | | TWA | 3 mg/m3 | N/A | OSHA Z1 |
| TRIPHENYL PHOSPHATE | | TWA | 3 mg/m3 | N/A | ACGIH |

Exposure limits/standards for materials that can be formed when handling this product: When mists/aerosols can occur the following are recommended: 5 mg/m³ - ACGIH TLV (inhalable fraction), 5 mg/m³ - OSHA PEL.

NOTE: Limits/standards shown for guidance only. Follow applicable regulations.

No biological limits allocated.

ENGINEERING CONTROLS

The level of protection and types of controls necessary will vary depending upon potential exposure conditions.

Control measures to consider:

Use explosion-proof ventilation equipment to stay below exposure limits.

PERSONAL PROTECTION

Personal protective equipment selections vary based on potential exposure conditions such as applications, handling practices, concentration and ventilation. Information on the selection of protective equipment for use with this material, as provided below, is based upon intended, normal usage.

Respiratory Protection: If engineering controls do not maintain airborne contaminant concentrations at a level which is adequate to protect worker health, an approved respirator may be appropriate. Respirator selection, use, and maintenance must be in accordance with regulatory requirements, if applicable. Types of respirators to be considered for this material include:

No special requirements under ordinary conditions of use and with adequate ventilation.

For high airborne concentrations, use an approved supplied-air respirator, operated in positive pressure mode. Supplied air respirators with an escape bottle may be appropriate when oxygen levels are inadequate, gas/vapor warning properties are poor, or if air purifying filter capacity/rating may be exceeded.

Hand Protection: Any specific glove information provided is based on published literature and glove manufacturer data. Glove suitability and breakthrough time will differ depending on the specific use conditions. Contact the glove manufacturer for specific advice on glove selection and breakthrough times for your use conditions. Inspect and replace worn or damaged gloves. The types of gloves to be considered for this material include:

If prolonged or repeated contact is likely, chemical resistant gloves are recommended. If contact with forearms is likely, wear gauntlet style gloves.

Eye Protection: If contact is likely, safety glasses with side shields are recommended.

Skin and Body Protection: Any specific clothing information provided is based on published literature or manufacturer data. The types of clothing to be considered for this material include:

If prolonged or repeated contact is likely, chemical, and oil resistant clothing is recommended.

Specific Hygiene Measures: Always observe good personal hygiene measures, such as washing after handling the material and before eating, drinking, and/or smoking. Routinely wash work clothing and protective equipment to remove contaminants. Discard contaminated clothing and footwear that cannot be cleaned. Practice good housekeeping.

ENVIRONMENTAL CONTROLS

Comply with applicable environmental regulations limiting discharge to air, water and soil. Protect the environment by applying appropriate control measures to prevent or limit emissions.

SECTION 9

PHYSICAL AND CHEMICAL PROPERTIES

Note: Physical and chemical properties are provided for safety, health and environmental considerations only and may not fully represent product specifications. Contact the Supplier for additional information.

GENERAL INFORMATION

Physical State: Liquid

Color: Red

Product Name: MOBIL AERO HFA
 Revision Date: 01 Oct 2015
 Page 7 of 12

Odor: Characteristic
Odor Threshold: N/D

IMPORTANT HEALTH, SAFETY, AND ENVIRONMENTAL INFORMATION

Relative Density (at 15 °C): 0.88
Flammability (Solid, Gas): N/A
Flash Point [Method]: >82°C (180°F) [ASTM D-93]
Flammable Limits (Approximate volume % in air): LEL: 0.7 UEL: 7.0 [Estimated]
Autoignition Temperature: >225°C (437°F)
Boiling Point / Range: N/D
Decomposition Temperature: N/D
Vapor Density (Air = 1): N/D
Vapor Pressure: [N/D at 20 °C]
Evaporation Rate (n-butyl acetate = 1): N/D
pH: N/A
Log Pow (n-Octanol/Water Partition Coefficient): N/D
Solubility in Water: Negligible
Viscosity: 13.8 cSt (13.8 mm2/sec) at 40 °C | 5.1 cSt (5.1 mm2/sec) at 100°C [ASTM D 445]
Oxidizing Properties: See Hazards Identification Section.

OTHER INFORMATION

Freezing Point: N/D
Melting Point: N/A
Pour Point: -60°C (-76°F) [ASTM D97]
DMSO Extract (mineral oil only), IP-346: < 3 %wt

SECTION 10 STABILITY AND REACTIVITY

REACTIVITY: See sub-sections below.

STABILITY: Material is stable under normal conditions.

CONDITIONS TO AVOID: Open flames and high energy ignition sources.

MATERIALS TO AVOID: Strong oxidizers

HAZARDOUS DECOMPOSITION PRODUCTS: Material does not decompose at ambient temperatures.

POSSIBILITY OF HAZARDOUS REACTIONS: Hazardous polymerization will not occur.

SECTION 11 TOXICOLOGICAL INFORMATION

INFORMATION ON TOXICOLOGICAL EFFECTS

| Hazard Class | Conclusion / Remarks |
|---|---|
| Inhalation | |
| Acute Toxicity: No end point data for material. | Minimally Toxic. Based on assessment of the components. |
| Irritation: No end point data for material. | Elevated temperatures or mechanical action may form vapors, mist, or fumes which may be irritating to the eyes, nose, throat, or lungs. |

Product Name: MOBIL AERO HFA
 Revision Date: 01 Oct 2015
 Page 8 of 12

| | |
|--|--|
| Ingestion | |
| Acute Toxicity: No end point data for material. | Minimally Toxic. Based on assessment of the components. |
| Skin | |
| Acute Toxicity: No end point data for material. | Minimally Toxic. Based on assessment of the components. |
| Skin Corrosion/Irritation: No end point data for material. | May dry the skin leading to discomfort and dermatitis. Based on assessment of the components. |
| Eye | |
| Serious Eye Damage/Irritation: No end point data for material. | May cause mild, short-lasting discomfort to eyes. Based on assessment of the components. |
| Sensitization | |
| Respiratory Sensitization: No end point data for material. | Not expected to be a respiratory sensitizer. |
| Skin Sensitization: No end point data for material. | Not expected to be a skin sensitizer. Based on assessment of the components. |
| Aspiration: Data available. | May be fatal if swallowed and enters airways. Based on physico-chemical properties of the material. |
| Germ Cell Mutagenicity: No end point data for material. | Not expected to be a germ cell mutagen. Based on assessment of the components. |
| Carcinogenicity: No end point data for material. | Not expected to cause cancer. Based on assessment of the components. |
| Reproductive Toxicity: No end point data for material. | Not expected to be a reproductive toxicant. Based on assessment of the components. |
| Lactation: No end point data for material. | Not expected to cause harm to breast-fed children. |
| Specific Target Organ Toxicity (STOT) | |
| Single Exposure: No end point data for material. | Not expected to cause organ damage from a single exposure. |
| Repeated Exposure: No end point data for material. | Not expected to cause organ damage from prolonged or repeated exposure. Based on assessment of the components. |

TOXICITY FOR SUBSTANCES

| NAME | ACUTE TOXICITY |
|----------------------------|--------------------------------------|
| 2,6-DI-TERT-BUTYL-P-CRESOL | Oral Lethality: LD50 0.89 g/kg (Rat) |

OTHER INFORMATION

For the product itself:

Repeated and/or prolonged exposure may cause irritation to the skin, eyes, or respiratory tract. Small amounts of liquid aspirated into the lungs during ingestion or from vomiting may cause chemical pneumonitis or pulmonary edema.

Contains:

Base oil severely refined: Not carcinogenic in animal studies. Representative material passes IP-346, Modified Ames test, and/or other screening tests. Dermal and inhalation studies showed minimal effects; lung non-specific infiltration of immune cells, oil deposition and minimal granuloma formation. Not sensitizing in test animals.

The following ingredients are cited on the lists below: None.

--REGULATORY LISTS SEARCHED--

Product Name: MOBIL AERO HFA
Revision Date: 01 Oct 2015
Page 9 of 12

1 = NTP CARC
2 = NTP SUS

3 = IARC 1
4 = IARC 2A

5 = IARC 2B
6 = OSHA CARC

SECTION 12 ECOLOGICAL INFORMATION

The information given is based on data available for the material, the components of the material, and similar materials.

ECOTOXICITY

Material -- Not expected to be harmful to aquatic organisms.

MOBILITY

More volatile component -- Highly volatile, will partition rapidly to air. Not expected to partition to sediment and wastewater solids.

Less volatile component -- Low solubility and floats and is expected to migrate from water to the land. Expected to partition to sediment and wastewater solids.

PERSISTENCE AND DEGRADABILITY

Biodegradation:

Components -- Expected to be inherently biodegradable

BIOACCUMULATION POTENTIAL

Majority of components -- Has the potential to bioaccumulate, however metabolism or physical properties may reduce the bioconcentration or limit bioavailability.

SECTION 13 DISPOSAL CONSIDERATIONS

Disposal recommendations based on material as supplied. Disposal must be in accordance with current applicable laws and regulations, and material characteristics at time of disposal.

DISPOSAL RECOMMENDATIONS

Product is suitable for burning in an enclosed controlled burner for fuel value or disposal by supervised incineration at very high temperatures to prevent formation of undesirable combustion products. Protect the environment. Dispose of used oil at designated sites. Minimize skin contact. Do not mix used oils with solvents, brake fluids or coolants.

REGULATORY DISPOSAL INFORMATION

RCRA Information: The unused product, in our opinion, is not specifically listed by the EPA as a hazardous waste (40 CFR, Part 261D), nor is it formulated to contain materials which are listed as hazardous wastes. It does not exhibit the hazardous characteristics of ignitability, corrosivity or reactivity and is not formulated with contaminants as determined by the Toxicity Characteristic Leaching Procedure (TCLP). However, used product may be regulated.

Empty Container Warning Empty Container Warning (where applicable): Empty containers may contain residue and can be dangerous. Do not attempt to refill or clean containers without proper instructions. Empty drums should be

Product Name: MOBIL AERO HFA
Revision Date: 01 Oct 2015
Page 10 of 12

completely drained and safely stored until appropriately reconditioned or disposed. Empty containers should be taken for recycling, recovery, or disposal through suitably qualified or licensed contractor and in accordance with governmental regulations. DO NOT PRESSURISE, CUT, WELD, BRAZE, SOLDER, DRILL, GRIND, OR EXPOSE SUCH CONTAINERS TO HEAT, FLAME, SPARKS, STATIC ELECTRICITY, OR OTHER SOURCES OF IGNITION. THEY MAY EXPLODE AND CAUSE INJURY OR DEATH.

SECTION 14 TRANSPORT INFORMATION

LAND (DOT)

Proper Shipping Name: COMBUSTIBLE LIQUID, N.O.S. (Distillates (Petroleum), Hydrotreated Light)
Hazard Class & Division: COMBUSTIBLE LIQUID
ID Number: NA1993
Packing Group: III
ERG Number: 128
Label(s): NONE
Transport Document Name: NA1993, COMBUSTIBLE LIQUID, N.O.S. (Distillates (Petroleum), Hydrotreated Light), COMBUSTIBLE LIQUID, PG III

Footnote: This material is not regulated under 49 CFR in a container of 119 gallon capacity or less when transported solely by land, as long as the material is not a hazardous waste, a marine pollutant, or specifically listed as a hazardous substance.

LAND (TDG): Not Regulated for Land Transport

SEA (IMDG): Not Regulated for Sea Transport according to IMDG-Code

Marine Pollutant: No

AIR (IATA): Not Regulated for Air Transport

SECTION 15 REGULATORY INFORMATION

OSHA HAZARD COMMUNICATION STANDARD: This material is considered hazardous in accordance with OSHA HazCom 2012, 29 CFR 1910.1200.

Listed or exempt from listing/notification on the following chemical inventories: AICS, DSL, ENCS, IECSC, KECI, PICCS, TCSI, TSCA

EPCRA SECTION 302: This material contains no extremely hazardous substances.

SARA (311/312) REPORTABLE HAZARD CATEGORIES: Fire. Immediate Health. Delayed Health.

SARA (313) TOXIC RELEASE INVENTORY: This material contains no chemicals subject to the supplier notification requirements of the SARA 313 Toxic Release Program.

Product Name: MOBIL AERO HFA
 Revision Date: 01 Oct 2015
 Page 11 of 12

The following ingredients are cited on the lists below:

| Chemical Name | CAS Number | List Citations |
|--|------------|------------------|
| DISTILLATES (PETROLEUM), HYDROTREATED LIGHT | 64742-47-8 | 1, 17, 18 |
| HYDROTREATED LIGHT NAPHTHENIC DISTILLATE (PETROLEUM) | 64742-53-6 | 1, 4, 13, 17, 18 |
| HYDROTREATED MIDDLE DISTILLATE (PETROLEUM) | 64742-46-7 | 1, 4, 17, 18 |

--REGULATORY LISTS SEARCHED--

| | | | |
|---------------|------------------|-------------------|-------------|
| 1 = ACGIH ALL | 6 = TSCA 5a2 | 11 = CA P65 REPRO | 16 = MN RTK |
| 2 = ACGIH A1 | 7 = TSCA 5e | 12 = CA RTK | 17 = NJ RTK |
| 3 = ACGIH A2 | 8 = TSCA 6 | 13 = IL RTK | 18 = PA RTK |
| 4 = OSHA Z | 9 = TSCA 12b | 14 = LA RTK | 19 = RI RTK |
| 5 = TSCA 4 | 10 = CA P65 CARC | 15 = MI 293 | |

Code key: CARC=Carcinogen; REPRO=Reproductive

| | |
|-------------------|--------------------------|
| SECTION 16 | OTHER INFORMATION |
|-------------------|--------------------------|

N/D = Not determined, N/A = Not applicable

KEY TO THE H-CODES CONTAINED IN SECTION 3 OF THIS DOCUMENT (for information only):

H227: Combustible liquid; Flammable Liquid, Cat 4
 H304: May be fatal if swallowed and enters airways; Aspiration, Cat 1
 H400: Very toxic to aquatic life; Acute Env Tox, Cat 1
 H410: Very toxic to aquatic life with long lasting effects; Chronic Env Tox, Cat 1

THIS SAFETY DATA SHEET CONTAINS THE FOLLOWING REVISIONS:

Revision Changes:

Section 01: Company Mailing Address information was modified.
 Section 05: Hazardous Combustion Products information was modified.
 Section 15: List Citations Table information was modified.
 Section 15: National Chemical Inventory Listing information was modified.
 Section 14: Marine Pollutant information was modified.
 Composition: Component Table information was modified.
 Section 08: Exposure Limits Table information was modified.
 Section 16: Revision Information - Implementation of GHS requirements phrase. information was deleted.

The information and recommendations contained herein are, to the best of ExxonMobil's knowledge and belief, accurate and reliable as of the date issued. You can contact ExxonMobil to insure that this document is the most current available from ExxonMobil. The information and recommendations are offered for the user's consideration and examination. It is the user's responsibility to satisfy itself that the product is suitable for the intended use. If buyer repackages this product, it is the user's responsibility to insure proper health, safety and other necessary information is included with and/or on the container. Appropriate warnings and safe-handling procedures should be provided to handlers and users. Alteration of this document is strictly prohibited. Except to the extent required by law,



Product Name: MOBIL AERO HFA
Revision Date: 01 Oct 2015
Page 12 of 12

re-publication or retransmission of this document, in whole or in part, is not permitted. The term, "ExxonMobil" is used for convenience, and may include any one or more of ExxonMobil Chemical Company, Exxon Mobil Corporation, or any affiliates in which they directly or indirectly hold any interest.

Internal Use Only

MHC: 2A, 0, 0, 0, 1, 1

PPEC: C

DGN: 2005454XUS (552975)

Copyright 2002 Exxon Mobil Corporation, All rights reserved