

MALABAR

INTERNATIONAL

AIRCRAFT MAINTENANCE & SUPPORT EQUIPMENT

OWNER'S MANUAL FOR MALABAR MODEL

8803A

**SINGLE STAGE FIXED HEIGHT
HYDRO - MECHANICAL
AVIATION TRIPOD JACK**

**READ
AND
SAVE**

**THIS
INSTRUCTION
MANUAL**

- * GENERAL DESCRIPTION
- * OPERATION
- * SERVICE
- * PARTS BREAKDOWN

For Service & Spare
Parts, Please Contact:

Malabar International
220 W. Los Angeles Avenue
Simi Valley, California 93065
Phone: (805) 581-0116
Fax: (805) 584-1624
E-mail: sales@malabar.com
Web site: <http://www.malabar.com>

OVER 65 YEARS OF SERVICE & EXPERIENCE

GENERAL DESCRIPTION, OPERATION, SERVICE AND PARTS BREAKDOWN

***MALABAR MODEL 8803A
SINGLE STAGE FIXED HEIGHT
HYDRO-MECHANICAL AVIATION TRIPOD JACK***

CAUTION: AIRCRAFT MANUFACTURER'S SPECIFICATIONS AND INSTRUCTIONS MUST BE FOLLOWED. IN THE EVENT OF CONTRADICTION BETWEEN AIRCRAFT MANUFACTURER'S SPECIFICATIONS AND MALABAR'S, AIRCRAFT MANUFACTURER'S SPECIFICATIONS WILL PREVAIL.

SPECIFICATIONS:

Rated Capacity-----	15 tons	(13.6 m. tons)
Side Load-----	15% of vertical load	
Roll Under Height -----	193.5 inches	(4915 mm)
Low Height -----	192 inches	(4877 mm)
Hydraulic Lift-----	102 inches	(2591 mm)
Extension Screw-----	26 inches	(660 mm)
Total Extended Height -----	320 inches	(8128 mm)
Oil Pressure at Rated Capacity-----	984 psig	(69 kg/sq cm)
Safety Pop-off Valves		
System Relief Valve set at-----	16.5 tons	(15.0 m. tons)
Thermal Relief Valve set at-----	18.8 tons	(17.1 m. tons)
Proof Load -----	22.5 tons	(20.4 m. tons)
Reservoir Capacity-----	16.4 gallons	(62.1 liters)
Hydraulic Fluid -----	MIL-H-5606 or equivalent	
Maximum Towing Speed -----	5 mph	(8 km/h)

GENERAL DESCRIPTION:

The Malabar Fixed Height Tripod Jack Model 8803A is a 15 ton capacity single stage hydraulic jack designed primarily for use in aircraft maintenance. It consists of a tripod structure, hydraulic cylinder assembly, reservoir, valve block assembly, hand pump assembly, tow handle, swivel casters and the following optional equipment:

- *Air pump
- *Load gauge
- *Adjustable swivel foot
- *Ladder
- *Remote control (platform operated)

The jack tow handle readily connects to tow vehicle for ease of transport. The jack should never be used as a personnel carrier while being towed or in motion. The jack leg pads are raised off the ground by spring loaded casters. The casters will retract and the pads rest on the ground when a load is applied to the jack. On jacks equipped with adjustable swivel foot, the jack leg pads have adjustable leveling feet for slightly uneven or sloping floors.

PREPARATION FOR USE:

The jack is shipped partially assembled. Erection is accomplished by following the suggested sequence below (also see figures 1A & 1B):

1. Install sling under tripod head of cylinder assembly and support from a crane or forklift capable of lifting 6000 pounds to a height of 20 feet.
2. Install upper legs, tripod head pins and retaining rings.
3. Install reservoir.
4. Install upper braces.
5. Install lower legs.
6. Install lower braces.
7. Install ladder.
8. Connect fluid line to cylinder.
9. Tighten all bolts.

If jack is equipped with adjustable swivel feet, perform the following procedure to calibrate bubble level:

1. Hang 2 plumb bobs (at 90°) from the tripod head with the plumb bob strings approximately parallel to the cylinder assembly (dial indicator magnetic bases work well as supports for the plumb bobs).
2. Stand on jack footpads and screw the footpad locknuts up to the end of the legs, continue turning footpad locknuts until weight of jack is off casters (one end of the pump handle fits into the footpad locknuts to provide extra leverage if required). Adjust footpad locknuts so both plumb bob strings are parallel to the cylinder assembly (carefully measure top and bottom from cylinder assembly to strings).
3. Remove cover from bubble level and adjust screws to center bubble. Lock adjustment screws and replace cover. Tag with date of calibration.
4. Raise footpads fully to stow position and reinsert pump handle in handle holder. Remove plumb bobs.
5. Bubble level should be checked periodically as directed by cognizant quality control department.

Before placing jack in operation, perform the following procedure:

1. Remove filler cap from the filler spout located at the side of the reservoir.
2. Fill jack reservoir to mark on dipstick with MIL-H-5606 hydraulic fluid or approved equivalent (reservoir capacity is approximately 16.4 gallons/62.1 liters). Jack plunger must be fully retracted before filling reservoir. Replace filler cap.
3. Open release valve and operate hand pump a few strokes to bleed all air trapped under hand pump.
4. Close release valve and operate hand pump to raise plunger approximately 1 inch.
5. Open release valve to retract plunger fully to bleed all air trapped under jack plunger. Close release valve.

PRE-OPERATION INSPECTION:

Each time the jack is to be used, inspect the following:

1. Check the tripod structure for rigidity. Make sure all bolts are tightened.
2. Check hydraulic line connections for leaks. Tighten as required.
3. Check for hydraulic fluid leaks around the base, reservoir, tripod head, air pump (if so equipped) and hand pump.
4. Check hand pump for proper operation.
5. Check swivel casters for proper operation.
6. Check reservoir fluid level with jack plungers fully retracted.

OPERATION:

CAUTION: PRIOR TO TOWING, ENGAGE THE TWO TRAILING SWIVEL CASTER LOCKS. ON JACKS EQUIPPED WITH ADJUSTABLE SWIVEL FOOT, ALWAYS FULLY RETRACT THE FOOTPADS BEFORE MOVING OR TOWING THE JACK.

1. Position the jack under the jacking pad of the aircraft. For maximum maneuverability, verify all swivel caster locks are disengaged.
2. Raise the extension screw by turning counterclockwise until the ship adapter contacts the jacking pad or as far as the screw will travel (26 inches maximum).
3. Verify the jack is leveled (shim footpads if necessary). The jack plunger should be plumb during lifting. On jacks equipped with adjustable swivel foot, check level using the bubble level mounted on the jack. Adjust the footpads to contact the ground and plumb the jack. The footpads are adjusted by standing on the footpad and adjusting the footpad locknut as required to extend the footpad. One end of the pump handle fits the footpad locknut for final adjusting.

CAUTION: ON JACKS EQUIPPED WITH AIR PUMP, AIR RELIEF VALVE MUST BE INSTALLED AT ALL TIMES. IF AIR RELIEF VALVE IS REMOVED, IT IS POSSIBLE TO OVER PRESSURIZE THE PNEUMATIC SYSTEM WHICH COULD CAUSE EQUIPMENT FAILURE AND POSSIBLE BODILY INJURY.

4. On jacks equipped with air pump, connect air supply (90-110 psig) to the 1/2 NPT air inlet at the air valve (A minimum of 28 scfm is required). Air relief valve must be properly installed. Do not attempt to remove air relief valve.

CAUTION: LOCKNUTS MUST BE INSTALLED AND OPERABLE ON JACK AT ALL TIMES. ALWAYS MAINTAIN LESS THAN 2 INCHES BETWEEN THE LOCKNUT AND THE TRIPOD HEAD IN ALL PHASES OF LOAD RAISING AND LOWERING.

5. To raise the load:
 - a. The jack is equipped with an adjustable hand pump. The hand pump handle length can be varied by inserting the quick release pin through the clamp and appropriate hole along the handle (see figure 4). A longer handle length provides greater pumping leverage for high pressure pump operation. A shorter handle will increase the plunger stroke and allow more oil pumped per stroke. This permits a more rapid raising of the jack plunger under a light or no load.
 - b. Close release valve located on the panel.
 - c. Operate the air valve or hand pump until the ship adapter contacts the jacking pad. Insure the ship adapter and the jacking pad are correctly mated. The load may now be raised by operating the air valve or hand pump.
 - d. Do not lift a load greater than the rated capacity of 15 tons.
 - e. Do not attempt to raise the plunger beyond the rated hydraulic lift (102 inches maximum).
 - f. Avoid lifting with excessive side load on the jack.
 - g. Spin the locknut down to the tripod head, as plunger is extending.
 - h. Keep the release valve closed at all times.
6. To lower the load:
 - a. Operate the air valve or hand pump to relieve pressure on the locknut.
 - b. Spin the locknut out of the way.
 - c. Slowly open the release valve located on the panel to lower the load. The speed of lowering is controlled by the amount the release valve is opened.
 - d. Close release valve after the plunger is fully retracted.
 - e. Lower the extension screw by turning clockwise.
 - f. Fully retract the adjustable footpads, if so equipped.
 - g. Cover the jack when not in use to prevent entrance of contaminants and water into the cylinder.

SERVICING:

Servicing the jack consists primarily of the following:

1. When in use, the reservoir should be kept at the proper level with hydraulic fluid MIL-H-5606 or approved equivalent. Always check fluid level with jack plunger fully retracted.
2. Grease the swivel casters.
3. Lubricate hand pump pivot pins.
4. Fill pump lubricator with SAE #10 oil.
5. If the jack has been put into storage or has not been used, the plunger must be fully extended and retracted every 90 days to exercise the seals. A portion of the lift should be operated by the air pump (if so equipped) and a portion by the hand pump.

DISASSEMBLY INSPECTION:

CAUTION: THERMAL RELIEF VALVE AND SYSTEM RELIEF VALVE, LOCATED IN THE VALVE BLOCK ASSEMBLY, SHOULD NOT BE REMOVED UNLESS ABSOLUTELY NECESSARY. THE THERMAL RELIEF VALVE IS SET TO BY-PASS HYDRAULIC FLUID BACK TO THE RESERVOIR AT 20-25% ABOVE THE RATED CAPACITY OF 15 TONS. THE SYSTEM RELIEF VALVE IS SET TO BY-PASS HYDRAULIC FLUID BACK TO THE RESERVOIR AT 5-10% ABOVE THE RATED CAPACITY OF 15 TONS. IF ADJUSTMENT IS REQUIRED, SEE PROCEDURE UNDER TESTING (SEE SHEET 5).

When necessary to disassemble the jack, drain all hydraulic fluid from reservoir and carefully inspect the following:

1. Inspect interior walls of jack cylinder and hand pump cylinder for smoothness and freedom from rust, nicks, scratches and excessive wear.
2. Check plunger, extension screw, cylinder, tripod head, etc., for corrosion, wear and condition of threads.
3. Verify that the extension screw has a positive stop to prevent it from being extended beyond its safe thread engagement.
4. Inspect packings, seals, gaskets and wipers in the cylinder assembly and hand pump for cuts, scratches, deterioration and distortion.
5. Inspect upper and lower bearings for excessive scoring and/or wear.
6. Check oil screen located in the valve block for cleanliness.
7. Inspect valves and valve seats in the hand pump body and valve block for scratches, dents and proper seating of the balls.
8. Inspect all pivot pins for wear, cracks, pits or evidence of damage or pending damage.
9. Check tripod structure for damages.
10. Inspect all areas for excessive dirt, oil, dust and chips.

REPAIR AND REPLACEMENT:

No definite time schedule can be established for the overhaul of the jack for replacement of the various moving parts. The number of times the jack is raised and lowered and the amount of load raised at each operation materially affect the life of the working parts. Do not overload the jack. Overloading is dangerous, will hasten the need for overhaul and may damage the jack. During overhaul, replace all parts that do not pass disassembly inspection requirements. Regardless of apparent condition, replace all parts marked with (◆) in the parts breakdown. A repair parts kit (P/N 8803APK) which contains all of the parts marked with (◆) is available and recommended to keep on hand at your facility. Coat all O-rings and back-up rings with hydraulic fluid MIL-H-5606 prior to assembly. Clean all metal parts with clean solvent and dry with compressed air. Lubricate all threads. Use teflon tape carefully on all pipe threads. Remove excess tape because it can clog valves and passages. If ball valves, located in valve block, do not seat

properly, they may need to be resealed by tapping the ball into the valve seat with a brass rod cupped at one end.

TESTING:

Place jack in a load indicating test fixture. Make sure the test adapter is 3/4 inch male spherical radius. Operate hand pump to extend plunger against the test adapter. Make sure ship adapter and test adapter are correctly mated. Load test the jack at rated capacity of 15 tons. If the jack fails to operate properly, check for trouble as indicated in the Trouble Shooting Chart (see sheet 8). With the plunger extended and supporting the capacity load, allow the jack to stand for 10 minutes. Any excess settling indicates leakage in the hand pump, check valves or jack packing seals. Check for hydraulic fluid leaks and replace all defective parts.

If adjustment is required for the thermal relief valve, perform the following procedure:

1. Remove plug (figure 3, item 8) to expose thermal relief valve. Close release valve (figure 3, item 2).
2. Place jack in a load indicating test fixture. Make sure the test adapter is 3/4 inch male spherical radius. Operate hand pump to extend plunger against the test adapter. Make sure ship adapter and test adapter are correctly mated.
3. While operating the hand pump, adjust set screw (figure 3, item 9) until the thermal relief valve by-passes hydraulic fluid back to the reservoir at 18.0 to 18.8 tons.
4. Replace plug (figure 3, item 8). Once more operate hand pump to verify correct setting.
5. Open release valve to relieve pressure.

If adjustment is required for the system relief valve, perform the following procedure:

1. Remove plug (figure 3, item 8) to expose system relief valve. Close release valve (figure 3, item 2).
2. Place jack in a load indicating test fixture. Make sure the test adapter is 3/4 inch male spherical radius. Operate hand pump to extend plunger against the test adapter.
3. While operating the hand pump, adjust set screw (figure 3, item 9) until the system relief valve by-passes hydraulic fluid back to the reservoir at 15.8 to 16.5 tons.
4. Replace plug (figure 3, item 8). Once more operate hand pump to verify correct setting.
5. Open release valve to relieve pressure.

SPECIAL TOOLS:

The following special tools are necessary to disassemble/reassemble the cylinder assembly. These tools may be purchased upon request:

<u>Part No.</u>	<u>Description</u>	<u>Qty</u>
73388	Spanner wrench, retaining nut-----	1
73198	Lifting tool, extension screw-----	1
70389	Lifting tool, plunger -----	1
70391	Lifting tool, tripod head -----	1
70390	Lifting tool, cylinder -----	1

RECOMMENDED SPARE PARTS:

The following spare parts are recommended and available upon request.

<i>Part No.</i>	<i>Description</i>	<i>Qty</i>
8803APK	Repair parts kit-----	1
56010-2	Valve block assembly-----	1
79366	Release valve knob-----	1
79365	Release valve stem-----	1
65228	Release valve lockscrew-----	1
55155	Safety pop-off valve assembly-----	2
79571-2	Hand pump assembly-----	1
55762-8	Pump handle-----	1
76347	Reservoir gasket-----	1
79562	Filler cap with dipstick-----	1
424-005	Drain cock valve-----	1
55991-4	Placard, tonnage, 15 ton-----	1
79596	Placard, instruction-----	1
55998	Sticker, Malabar-----	2
55994	Sticker, fluid-----	1
75940	Sticker, towing-----	1
73334A	Swivel caster-----	3
73309	Lower bearing-----	1
73314	Upper bearing-----	1
73318	Ship adapter-----	1
79595	Rain hat-----	1
* 441-004	Air pump-----	1
* 441-031	Seal kit, air pump-----	1
* 421-004	Air valve-----	1
* 425-001	Air relief valve-----	1
* 471-001	Lubricator-----	1
* 499-002	Muffler-----	1
* 481-002	Oil screen-----	1
* 70348	Load gauge-----	1
* 424-001	Shutoff valve-----	1
* 75941	Sticker, footpad-----	3
* 79225	Level assembly-----	1
* 76378	Safety chain assembly-----	1
* 421-004	Air valve-----	1
* 85416	Release valve-----	1
* 76158	Placard, caution-----	2

* Optional equipment – These parts required only when supplied with jack

PNEUMATIC / HYDRAULIC DIAGRAM

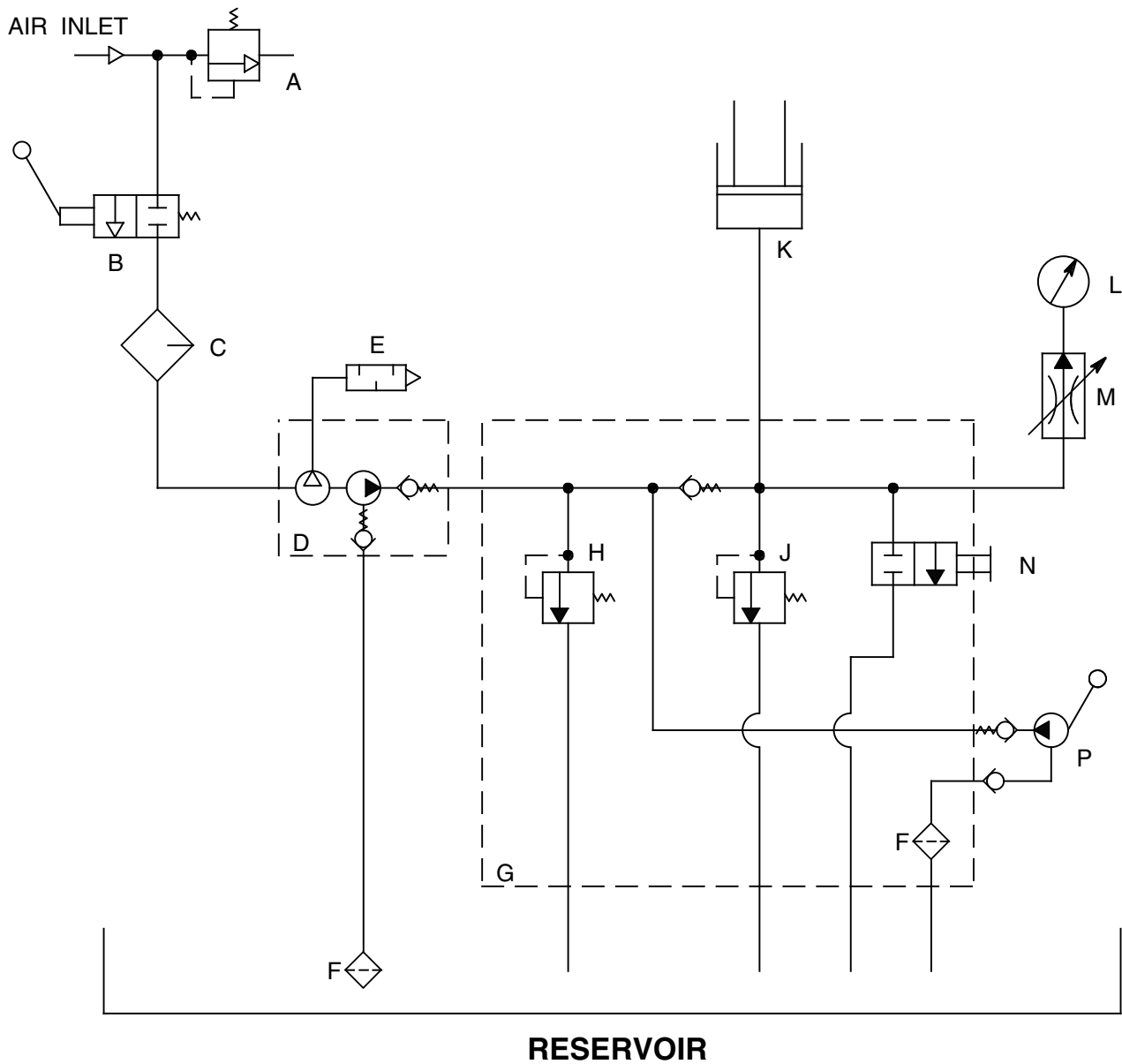

A - AIR RELIEF VALVE
 B - AIR VALVE
 C - LUBRICATOR
 D - AIR PUMP
 E - MUFFLER
 F - OIL SCREEN
 G - VALVE BLOCK

H - SYSTEM RELIEF VALVE
 J - THERMAL RELIEF VALVE
 K - CYLINDER ASSEMBLY
 L - LOAD GAUGE
 M - SHUTOFF VALVE
 N - RELEASE VALVE
 P - HAND PUMP

PNEUMATIC / HYDRAULIC DIAGRAM WITH REMOTE CONTROL

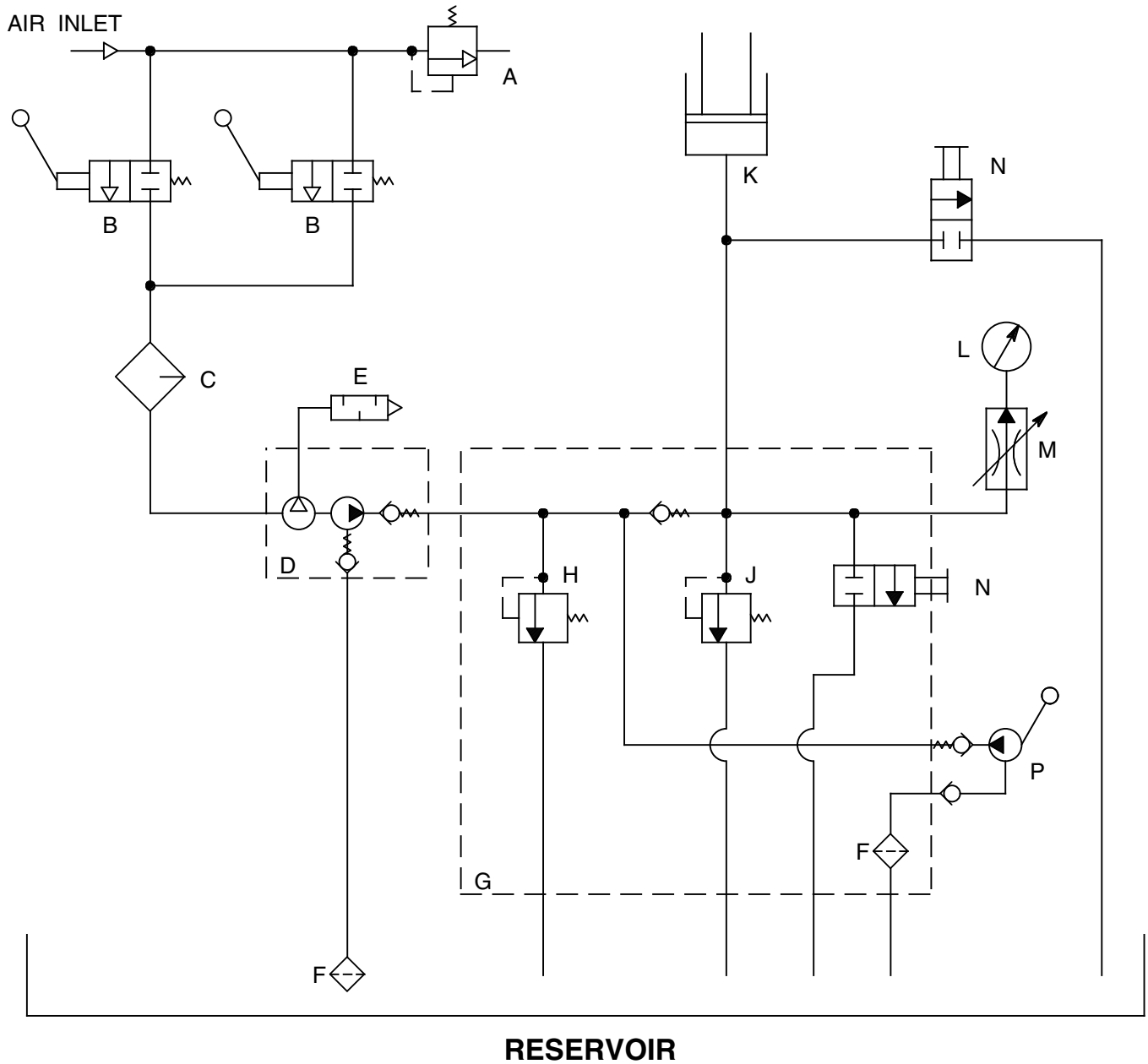

- A - AIR RELIEF VALVE
- B - AIR VALVE
- C - LUBRICATOR
- D - AIR PUMP
- E - MUFFLER
- F - OIL SCREEN
- G - VALVE BLOCK

- H - SYSTEM RELIEF VALVE
- J - THERMAL RELIEF VALVE
- K - CYLINDER ASSEMBLY
- L - LOAD GAUGE
- M - SHUTOFF VALVE
- N - RELEASE VALVE
- P - HAND PUMP

TROUBLE SHOOTING CHART

TROUBLE	PROBABLE CAUSE	REMEDY
Jack will not raise.	Release valve open. (Oil passing back into reservoir.)	Close valve firmly.
	Intake valve open. (Oil passing back into reservoir.)	Pump rapidly to flush dirt off.
	Discharge valve open. (Oil passing back into pump chamber.)	Pump rapidly to flush dirt off.
	Sticking intake valve.	Remove pump from jack base. Unscrew valve block. Clean or replace valve.
	Clogged screen.	Remove and clean.
	Lack of oil. Air under plunger.	Refill. Check for leaks. Bleed air out by opening release valve. Pump rapidly a few times and close release valve.
Jack will not raise to full height.	Lack of oil.	Refill, check for leaks.
	Sticking intake valve.	Remove pump from jack base. Unscrew valve block. Clean or replace ball valves. Re-tighten or repair.
Jack will not raise capacity load.	High pressure leaks. (At pump or release valve.)	Reseat valve.
	Leaky release valve.	Reseat valve and clean valve block.
Jack raises and falls during each stroke.	Leaky discharge valve.	Tighten or replace ball valve or packing.
Jack will not hold up load.	Leaky release valve.	Reseat valve.
	Defective "O" ring and back up ring.	Remove plunger and replace "O" ring and back up ring.
Jack will not lower the load.	Damaged release valve.	Remove and replace parts as needed.
	Bent plunger.	Replace.
Jack will not close completely.	Air under plunger.	Bleed air out. Open release valve and pump rapidly several times. Close valve.
Handle stroke only partly effective.	Air in pump chamber.	Open release valve and pump rapidly several times. Close valve.
	Sticking intake valve.	Remove pump and clean valve block.
	Clogged screen.	Remove and clean.
Handle raises without effort.	Leaky intake valve.	Remove pump and clean valve block.
Handle snaps back.	Sticking intake valve.	Open release valve. Pump rapidly several times. close valve.
	Clogged screen.	Remove and clean.

◆ PART OF REPAIR PARTS KIT

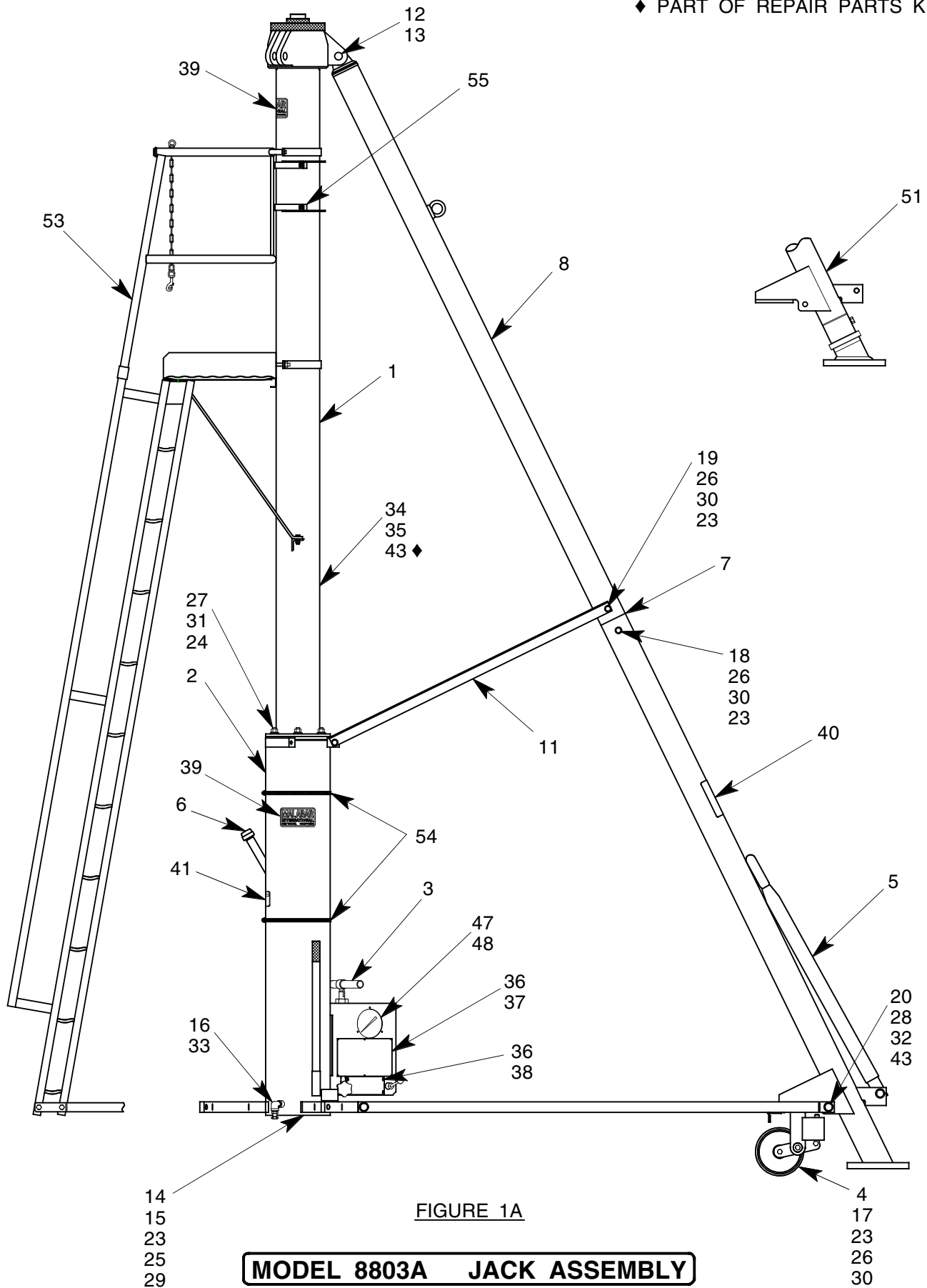

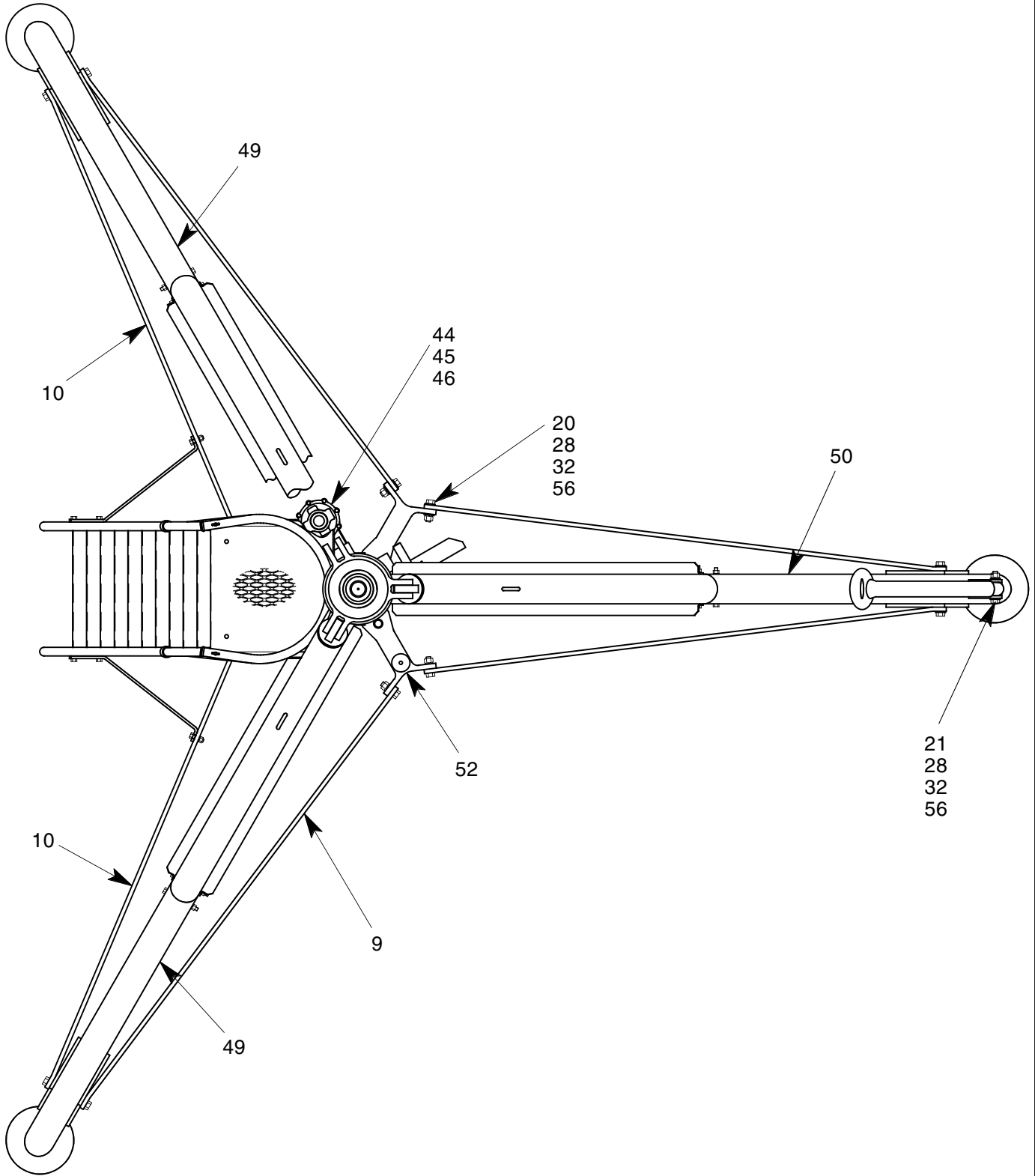

FIGURE 1B

MODEL 8803A JACK ASSEMBLY

MODEL 8803A JACK ASSEMBLY PARTS LIST

NO.	QTY	PART NO.	DESCRIPTION	NO.	QTY	PART NO.	DESCRIPTION
1	1	880399	CYLINDER ASSEMBLY				
2	1	880344	RESERVOIR				
3	1	56010-2	VALVE BLOCK ASSEMBLY				
4	3	73334A	SWIVEL CASTER				
5	1	79535	TOW HANDLE				
6	1	79562	BREATHER CAP W/ DIPSTICK				
7	3	880216	LEG SLEEVE				
8	3	880345	UPPER LEG				
9	4	880355-1	BRACE				
10	2	880355-2	BRACE				
11	6	880349	UPPER BRACE				
12	3	73319	TRIPOD HEAD PIN				
13	6	55923-125	RETAINING RING				
14	1	76347	RESERVOIR GASKET				
15	1	76346	RESERVOIR COVER				
16	1	424-005	DRAIN COCK VALVE				
17	12	321-006	HHCS, 1/2-13 x 1 3/4 LG				
18	3	321-238	HHCS, GR 5, 1/2-13 x 5 1/2 LG				
19	6	321-237	HHCS, GR 5, 1/2-13 x 6" LG				
20	12	321-107	HHCS, GR 5, 3/4-10 x 2 1/2 LG				
21	1	321-306	HHCS, 3/4-10 x 4 1/2 LG				
22	6	362-003	FLAT WASHER, 3/8 SAE				
23	36	362-005	FLAT WASHER, 1/2 SAE				
24	6	362-002	FLAT WASHER, 5/8 SAE				
25	6	363-003	SPLIT LOCKWASHER, 3/8				
26	21	363-004	SPLIT LOCKWASHER, 1/2				
27	6	363-005	SPLIT LOCKWASHER, 5/8				
28	13	363-006	SPLIT LOCKWASHER, 3/4				
29	6	351-002	HEX NUT, 3/8-16				
30	21	351-003	HEX NUT, 1/2-13				
31	6	351-006	HEX NUT, 5/8-11				
32	13	351-004	HEX NUT, 3/4-10				
33	1	712-011	ELBOW, STREET, 1/2 NPT				
34	A/R	732-010	TUBING, 3/8 OD x .065 WALL				
35	1	721-005	CONN., 3/8 TUBE x 3/8 SAE				
36	10	397-005	SELF TAP SCREW, #4 x 3/16 LG				
37	1	79596	PLACARD, INSTRUCTION				
38	1	55991-4	PLACARD, TONNAGE, 15 TON				
39	2	55998	STICKER, MALABAR				
40	1	75940	STICKER, TOWING				
41	1	55994	STICKER, FLUID				
42	1	79595	RAIN HAT (NOT SHOWN)				
43	1	MS28778-6	O-RING (PART OF ITEM 35)				
44	1	717-008	PLUG, USED w/ NO AIR PUMP				
45	1	717-003	PLUG, USED w/ NO AIR PUMP				
46	1	73632	AIR PUMP KIT				
47	1	717-001	PLUG, USED w/ NO GAUGE				
48	1	880310	LOAD GAUGE KIT				
49	2	880347	LOWER LEG				
50	1	880358	LOWER LEG w/ TOW BRKT				
51	1	880352	ADJUSTABLE FOOT KIT				
52	1	79225	LEVEL ASSEMBLY				
53	1	880357	LADDER ASSEMBLY KIT				
54	2	394-040	HOSE CLAMP				
55	1	880395	REMOTE CONTROL KIT				
56	26	362-007	FLAT WASHER, 3/4 SAE				

◆ PART OF REPAIR PARTS KIT

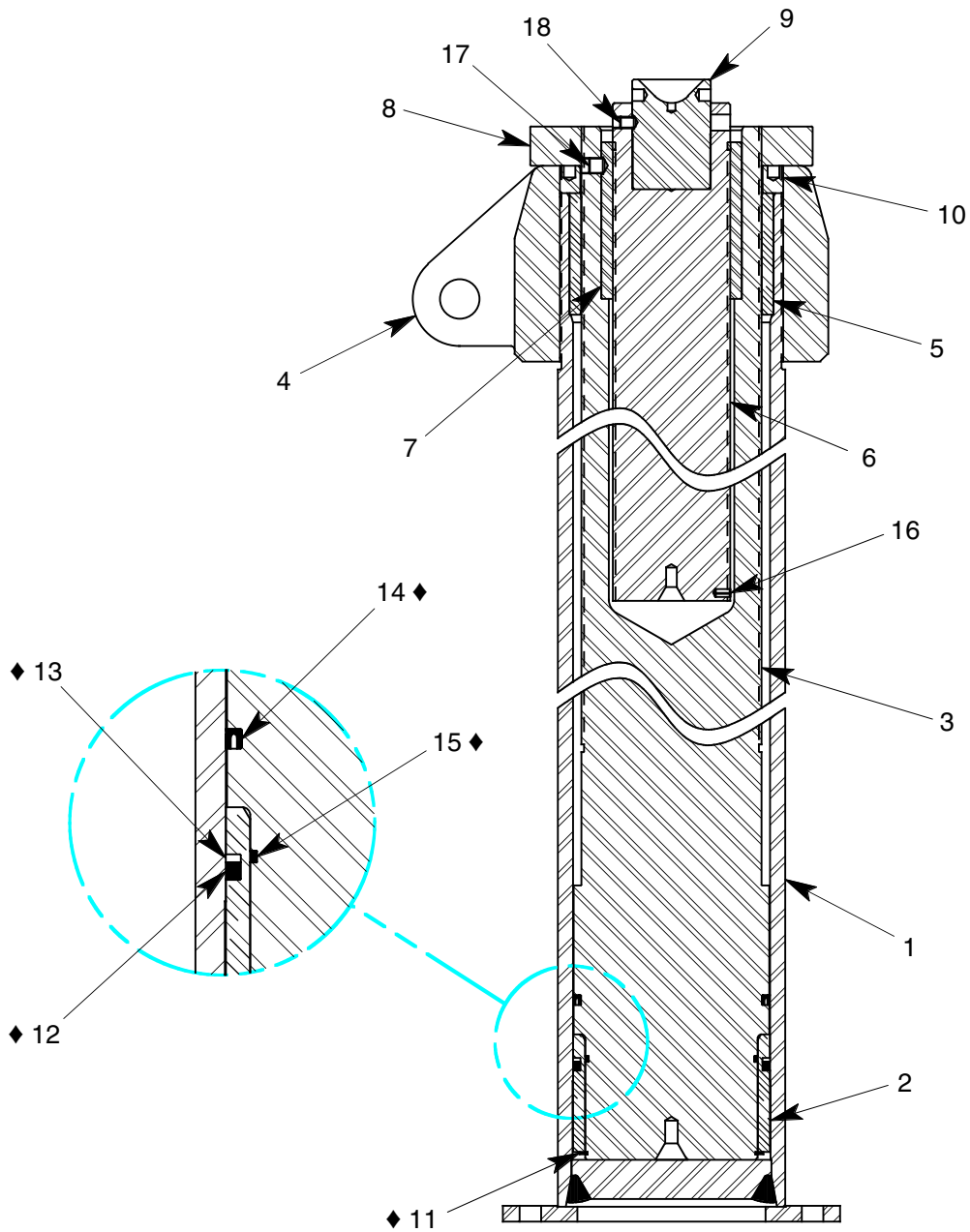

FIGURE 2

880399 CYLINDER ASSEMBLY

NO.	QTY	PART NO.	DESCRIPTION	NO.	QTY	PART NO.	DESCRIPTION
1	1	880307	CYLINDER	10	1	73320	RETAINING NUT
2	1	73309	LOWER BEARING	11	1	55924-550	RETAINING RING
3	1	880309	PLUNGER	12	1	55925-435	O-RING
4	1	73313	TRIPOD HEAD	13	1	55929-435	BACK-UP RING
5	1	73314	UPPER BEARING	14	1	55931-435	TEFLON O-RING W/ GROOVE
6	1	881011	EXTENSION SCREW	15	1	55932-252	O-RING
7	1	73316	EXTENSION SCREW NUT	16	1	371-039	ROLL PIN, 1/4 x 1/2 LG
8	1	73317	LOCKNUT	17	1	331-001	SHSS, 1/2-20 x 1/2 LG
9	1	73318	SHIP ADAPTER	18	1	331-002	SHSS, 3/8-16 x 1/2 LG

◆ PART OF REPAIR PARTS KIT

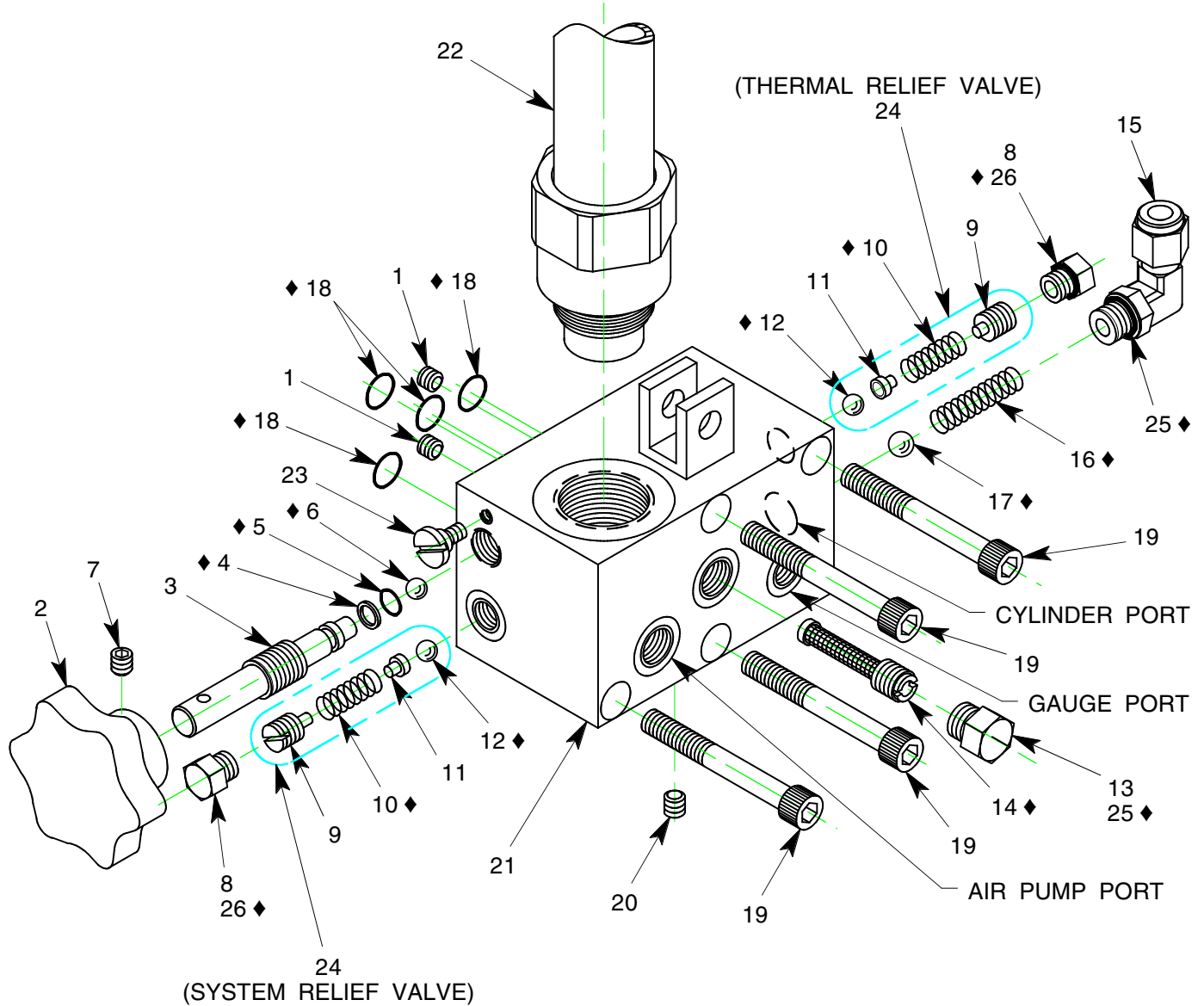
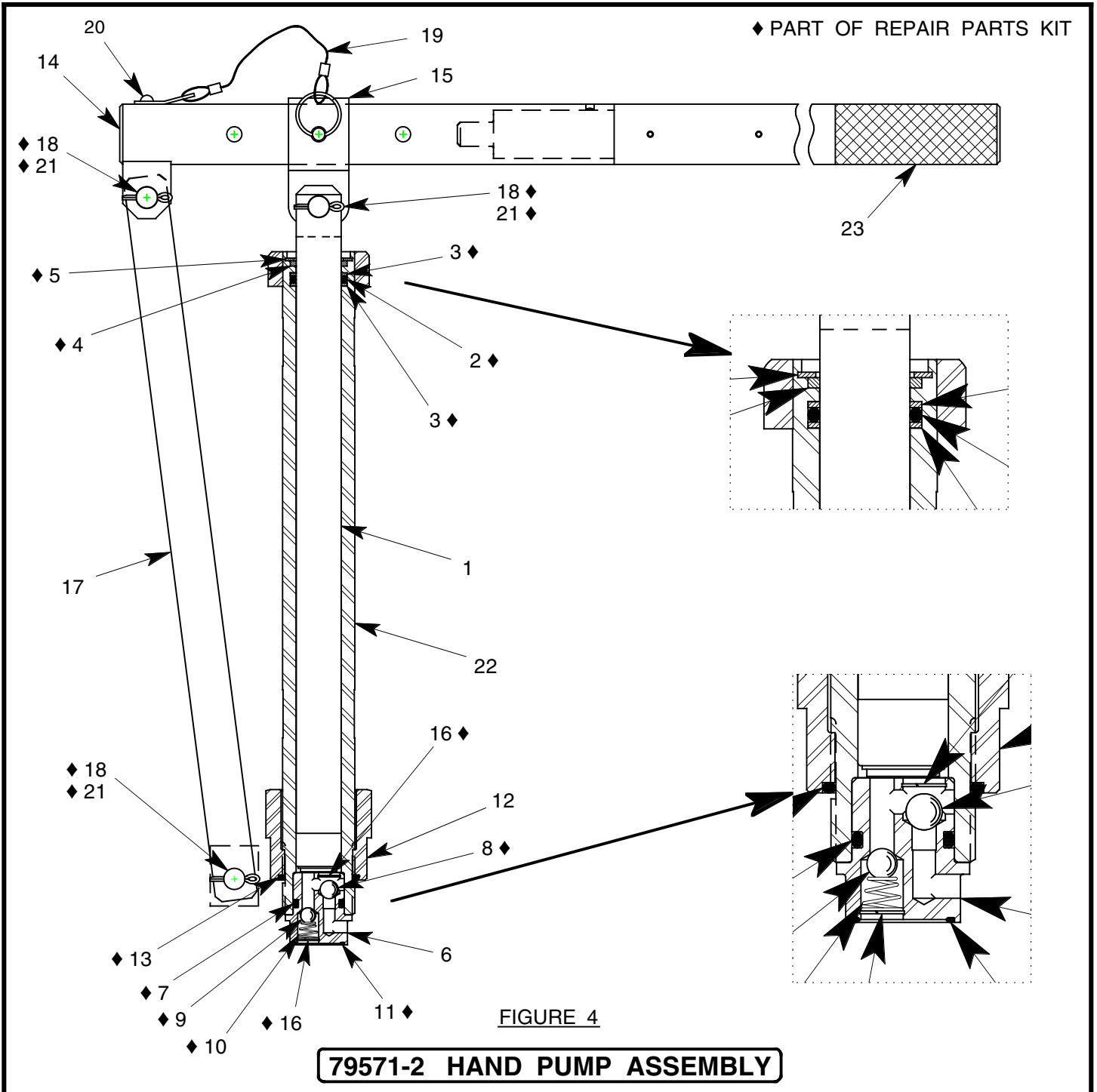

FIGURE 3

56010-2 VALVE BLOCK ASSEMBLY

NO.	QTY	PART NO.	DESCRIPTION	NO.	QTY	PART NO.	DESCRIPTION
1	2	717-048	PLUG, FLUSH, 1/16 NPT	14	1	55568	OIL SCREEN
2	1	79366	RELEASE VALVE KNOB	15	1	722-018	ELBOW, 3/8 T x 3/8 SAE
3	1	79365	RELEASE VALVE STEM	16	1	79367	SPRING
4	1	55929-011	BACK-UP RING	17	1	412-001	STEEL BALL, 3/8 DIA
5	1	55925-011	O-RING	18	4	55925-014	O-RING
6	1	412-002	STEEL BALL, 5/16 DIA	19	4	323-009	SHCS, 3/8-24 x 3" LG
7	1	331-004	SETSCREW, 5/16-24 x 5/16 LG	20	1	717-010	PLUG, SOC HD, 1/16 NPT
8	2	717-001	PLUG, 1/4 SAE	21	1	76345	VALVE BLOCK
9	2	55148	SAFETY BYPASS SCREW	22	1	79571-2	HAND PUMP ASSY
10	2	55154H	SPRING	23	1	65228	RELEASE VALVE LOCKSCREW
11	2	55153	SPRING GUIDE	24	2	55155	SAFETY POP-OFF VALVE ASSY
12	2	412-004	STEEL BALL, 1/4 DIA	25	2	MS28778-6	O-RING (PART OF ITEM 13 & 15)
13	1	717-003	PLUG, 3/8 SAE	26	2	MS28778-4	O-RING (PART OF ITEM 8)



NO.	QTY	PART NO.	DESCRIPTION	NO.	QTY	PART NO.	DESCRIPTION
1	1	55738	PISTON	13	1	55925-220	O-RING
2	1	55925-213	O-RING	14	1	55761	FULCRUM
3	2	55922-18	BACK-UP RING	15	1	55745	PUMP HANDLE CLAMP
4	1	55728	SCRAPER RING	16	2	55927-43	RETAINING RING
5	1	55729	RETAINING RING	17	1	55739	LINK
6	1	55753	PUMP BODY	18	3	372-001	COTTER PIN, 3/32 x 3/4 LG
7	1	55925-211	O-RING	19	1	370-001	QUICK RELEASE PIN, 1/4 DIA
8	1	412-001	STEEL BALL, 3/8 DIA	20	1	MS51861-44C	SELF TAPPING SCREW, #10
9	1	412-002	STEEL BALL, 5/16 DIA	21	3	373-001	FLAT HEAD PIN, 7/16 DIA
10	1	55754	SPRING	22	1	79563	CYLINDER
11	1	55925-021	O-RING	23	1	55762-8	PUMP HANDLE
12	1	79564	PUMP CYLINDER NUT				

* PARTS ARE LOCATED INSIDE
RESERVOIR TANK

◆ PART OF REPAIR PARTS KIT

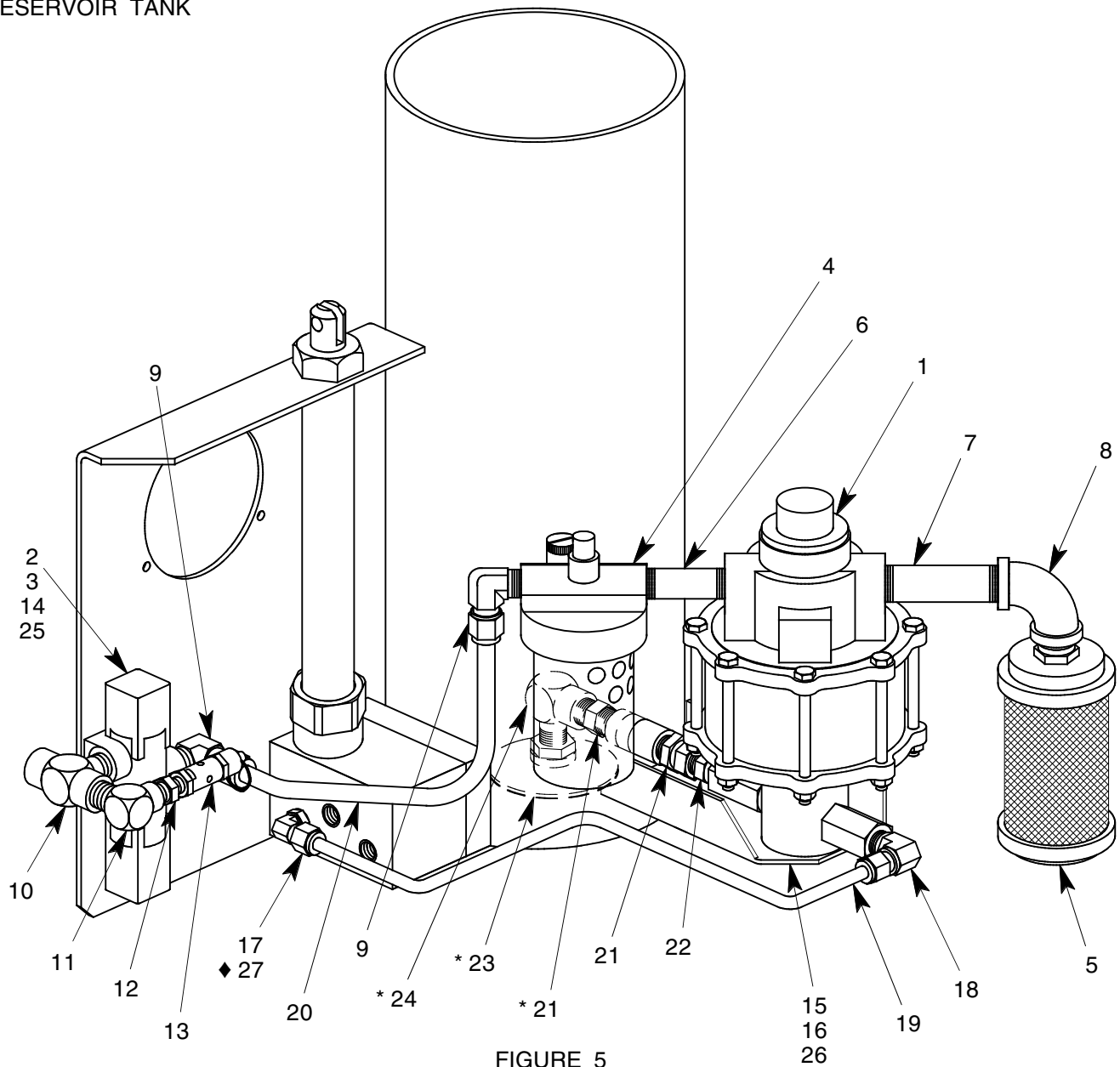

73632 AIR PUMP KIT

NO.	QTY	PART NO.	DESCRIPTION	NO.	QTY	PART NO.	DESCRIPTION
1	1	441-004	AIR PUMP	15	2	321-013	HHCS, 3/8-24 x 1" LG
2	2	392-001	STUD	16	2	363-003	SPLIT LOCKWASHER, 3/8
3	1	421-004	AIR VALVE	17	1	722-018	ELBOW, 3/8 T x 3/8 SAE
4	1	471-001	LUBRICATOR	18	1	722-015	ELBOW, 3/8 T x 1/2 MPT
5	1	499-002	MUFFLER	19	A/R	732-010	TUBE, 3/8 O.D. x .065 WALL
6	1	711-006	NIPPLE, BRASS, 1/2 x 3" LG	20	A/R	732-001	TUBE, 1/2 O.D. x .049 WALL
7	1	711-010	NIPPLE, BRASS, 3/4 x 3" LG	21	2	711-004	NIPPLE, 1/2 MPT
8	1	712-063	ELBOW, BRASS, 3/4 FPT	22	1	719-001	SWIVEL ADAPTER
9	2	722-013	ELBOW, 1/2 T x 1/2 MPT	23	1	481-002	OIL SCREEN
10	1	713-021	TEE, BRANCH, 1/2 NPT	24	1	712-011	ELBOW, STREET, 1/2 NPT
11	1	712-032	ELBOW, 1/2 MPT x 3/8 FPT	25	2	363-002	SPLIT LOCKWASHER, 5/16
12	1	714-009	REDUCER, 3/8 MPT x 1/4 FPT	26	2	361-001	FLAT WASHER, 3/8
13	1	425-001	AIR RELIEF VALVE	27	1	MS28778-6	O-RING (PART OF ITEM 17)
14	2	359-001	ALLEN NUT, 5/16-18				

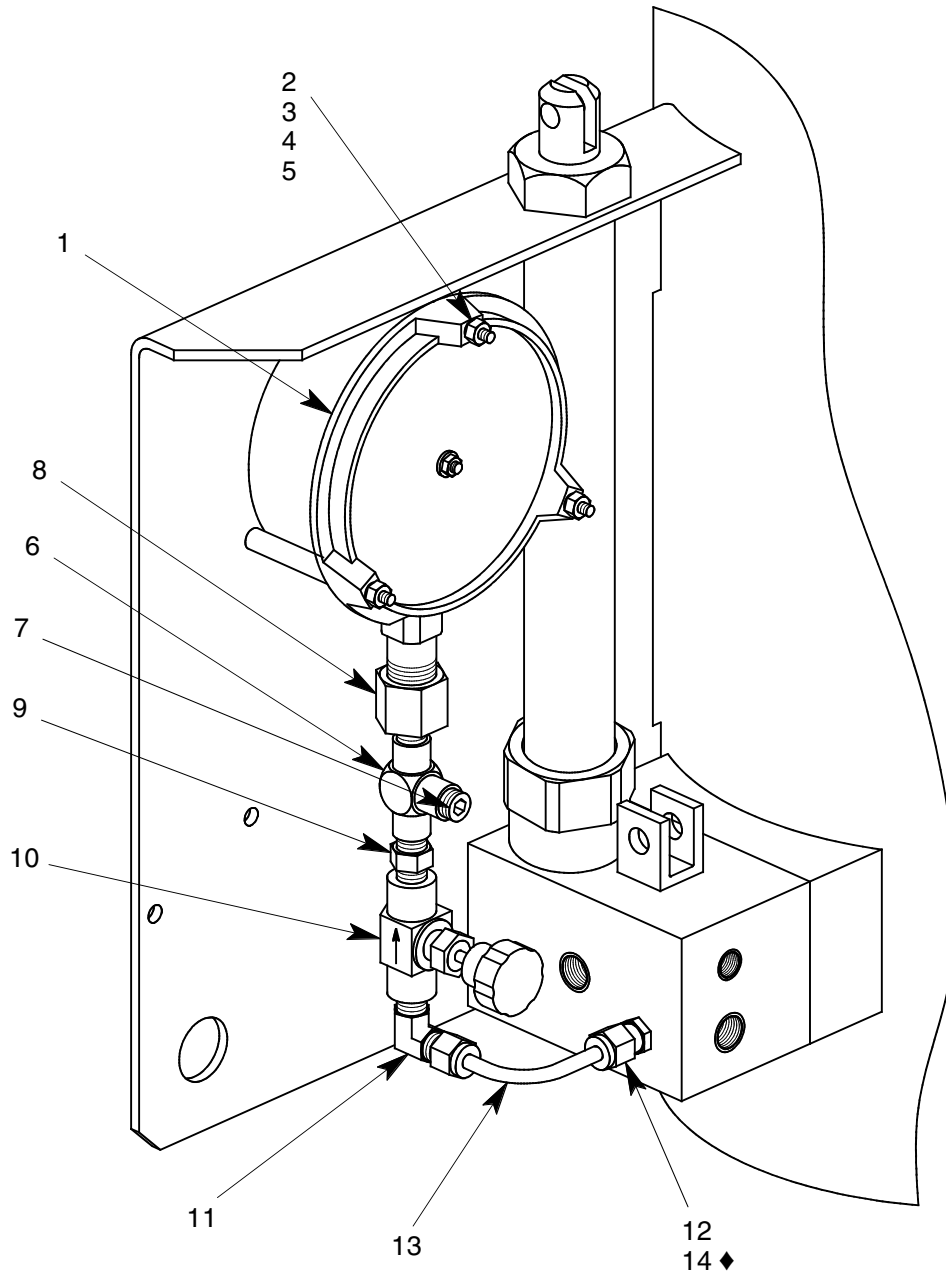

FIGURE 6

880310 LOAD GAUGE KIT

NO.	QTY	PART NO.	DESCRIPTION	NO.	QTY	PART NO.	DESCRIPTION
1	1	880311	LOAD GAUGE	8	1	714-001	REDUCER, 1/2 FPT x 1/4 MPT
2	3	323-091	SHCS, 10-32 x 4" LG	9	1	711-003	NIPPLE, 1/4 MPT
3	3	363-009	SPLIT LOCKWASHER, # 10	10	1	424-001	SHUTOFF VALVE
4	3	351-008	HEX NUT, 10-32	11	1	722-021	ELBOW, 1/4 T x 1/4 MPT
5	3	876026	SPACER	12	1	721-011	CONNECTOR, 1/4 T x 1/4 SAE
6	1	713-002	TEE, 1/4 FPT	13	A/R	732-003	TUBE, 1/4 O.D. x .035 WALL
7	1	717-006	PLUG, 1/4 MPT	14	1	MS28778-4	O-RING (PART OF ITEM 12)

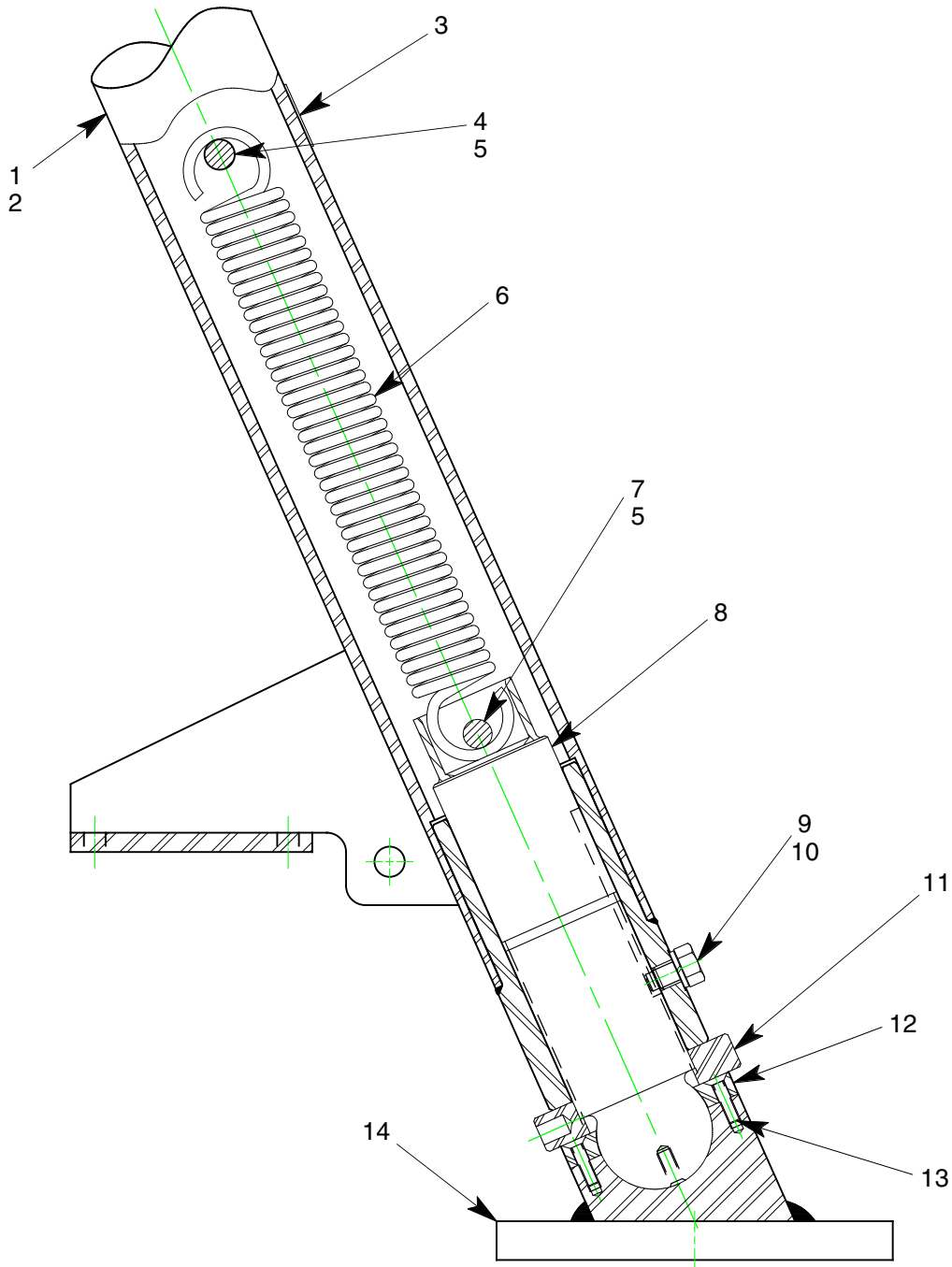

FIGURE 7

880325 ADJUSTABLE FOOT KIT

NO.	QTY	PART NO.	DESCRIPTION	NO.	QTY	PART NO.	DESCRIPTION
1	2	880326	LOWER LEG	8	3	73342	FOOT SCREW
2	1	880327	LOWER LEG w/ TOW BRKT	9	3	79347	GUIDE SCREW
3	3	75941	STICKER, FOOTPAD	10	3	363-005	SPLIT LOCKWASHER, 5/8
4	3	73347	LONG SPRING PIN	11	3	73343	FOOT SCREW LOCKNUT
5	12	55923-75	RETAINING RING	12	3	73344	RETAINING RING
6	3	73345	SPRING	13	18	325-003	FSHCS, 5/16-18 x 1 1/4 LG
7	3	73348	SHORT SPRING PIN	14	3	73734	FOOT

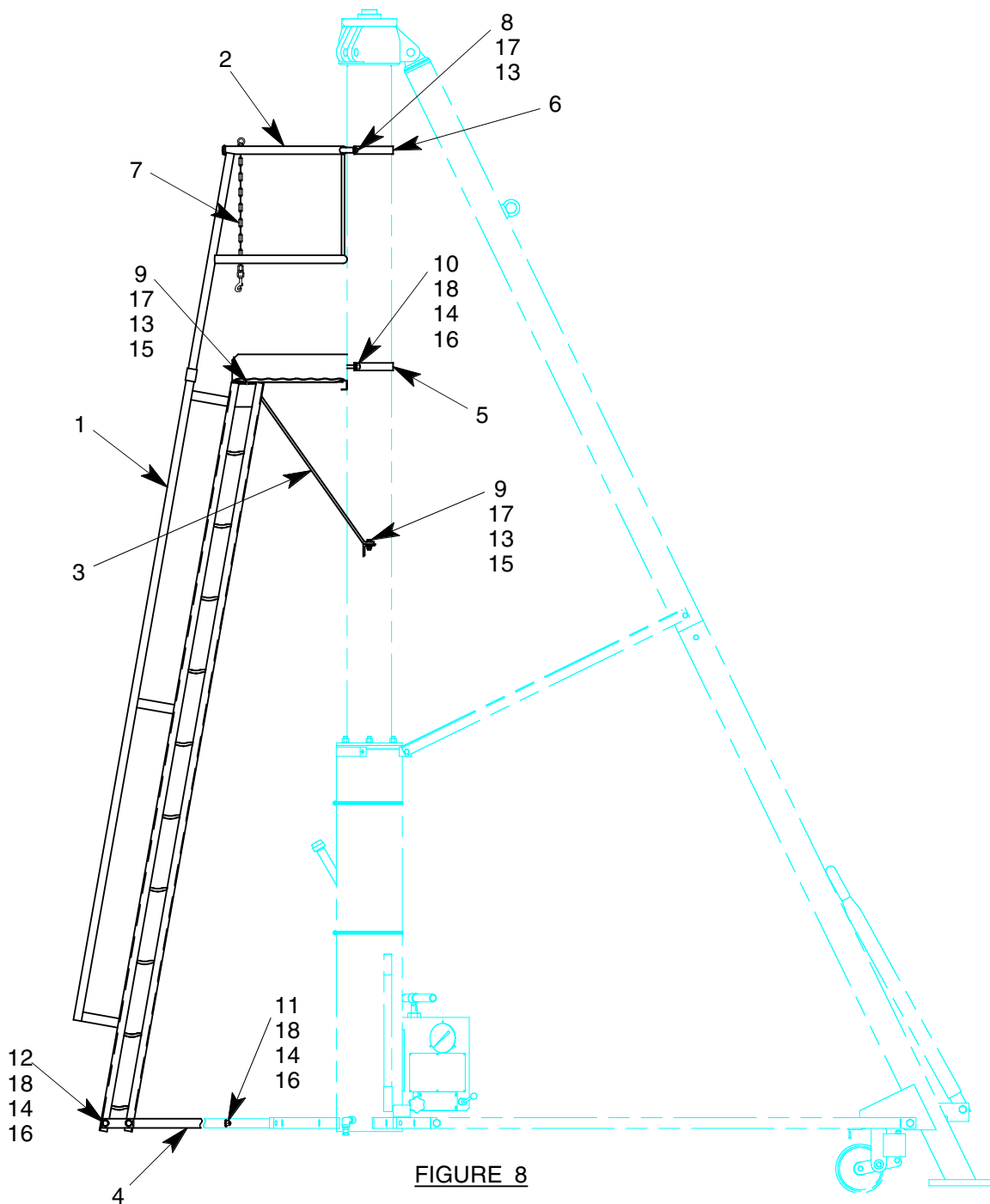

FIGURE 8

880357 LADDER ASSEMBLY KIT

NO.	QTY	PART NO.	DESCRIPTION	NO.	QTY	PART NO.	DESCRIPTION
1	1	880337	LADDER AND PLATFORM	10	4	321-014	HHCS, 1/2-13 x 1 1/2 LG
2	1	880238	RAIL	11	2	321-005	HHCS, 1/2-13 x 2" LG
3	2	880236	LADDER SUPPORT BRACE	12	2	321-032	HHCS, 1/2-13 x 2 1/2 LG
4	2	880356	LADDER BRACE	13	6	363-003	SPLIT LOCKWASHER, 3/8
5	1	73355	STRAP	14	8	363-004	SPLIT LOCKWASHER, 1/2
6	1	73355-1	STRAP	15	4	351-002	HEX NUT, 3/8-16
7	1	76378	SAFETY CHAIN ASSEMBLY	16	8	351-003	HEX NUT, 1/2-13
8	2	321-008	HHCS, 3/8-16 x 1 1/4 LG	17	10	362-003	FLAT WASHER, 3/8 SAE
9	4	321-162	HHCS, 3/8-16 x 1 3/8 LG	18	16	362-005	FLAT WASHER, 1/2 SAE

◆ PART OF REPAIR PARTS KIT

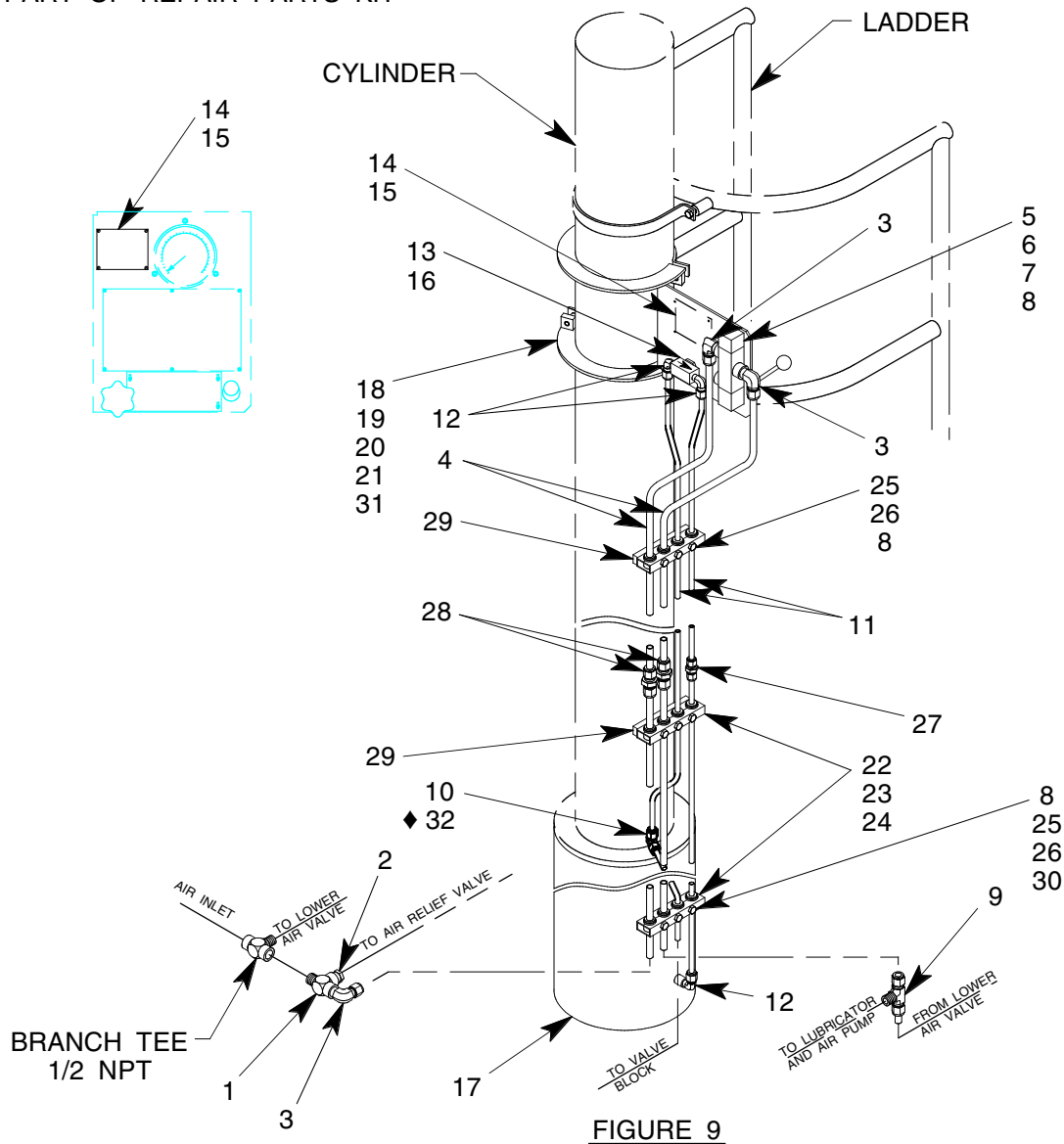

FIGURE 9

880395 REMOTE CONTROL KIT

NO.	QTY	PART NO.	DESCRIPTION	NO.	QTY	PART NO.	DESCRIPTION
1	1	713-029	TEE, RUN, 1/2 NPT	17	1	880365	RESERVOIR
2	1	714-003	REDUCER, 1/2 MPT x 1/4 FPT	18	2	74977	STRAP
3	3	722-013	ELBOW, 1/2 TUBE x 1/2 MPT	19	1	74978	PANEL
4	A/R	732-001	TUBE, 1/2 O.D. x .049 WALL	20	4	321-028	HHCS, 3/8-16 x 1 1/2 LG
5	1	421-004	AIR VALVE	21	4	363-003	SPLIT LOCKWASHER, 3/8
6	2	392-001	STUD, 5/16-18 x 3/4 LG	22	6	394-033	SPLIT BUSHING, 1/2 TUBE
7	2	359-001	ALLEN NUT, 5/16-18	23	6	394-034	SPLIT BUSHING, 3/8 TUBE
8	11	363-002	SPLIT LOCKWASHER, 5/16	24	3	394-031	CLAMPING UNIT
9	1	723-033	TEE, BRANCH, 1/2 T x 1/2 MPT	25	9	321-080	HHCS, 5/16-18 x 2" LG
10	1	723-014	TEE, 3/8 TUBE x 3/8 SAE	26	11	362-002	FLAT WASHER, 5/16
11	A/R	732-010	TUBE, 3/8 O.D. x .065 WALL	27	1	723-027	UNION, 3/8 TUBE
12	3	722-014	ELBOW, 3/8 TUBE x 1/4 MPT	28	2	721-133	UNION, 1/2 TUBE
13	1	85416	RELEASE VALVE	29	1	76160	TUBE MOUNTING BRACKET
14	2	76158	CAUTION PLACARD	30	3	351-012	HEX NUT, 5/16-18
15	8	397-010	SELF TAPPING SCREW, #6	31	4	362-003	FLAT WASHER, 3/8 SAE
16	A/R	491-044	SAFETY LOCK WIRE, .025 DIA	32	1	MS28778-6	O-RING (PART OF ITEM 10)